

DPS5000

SDI-12 Pressure Transducer Instruction Manual

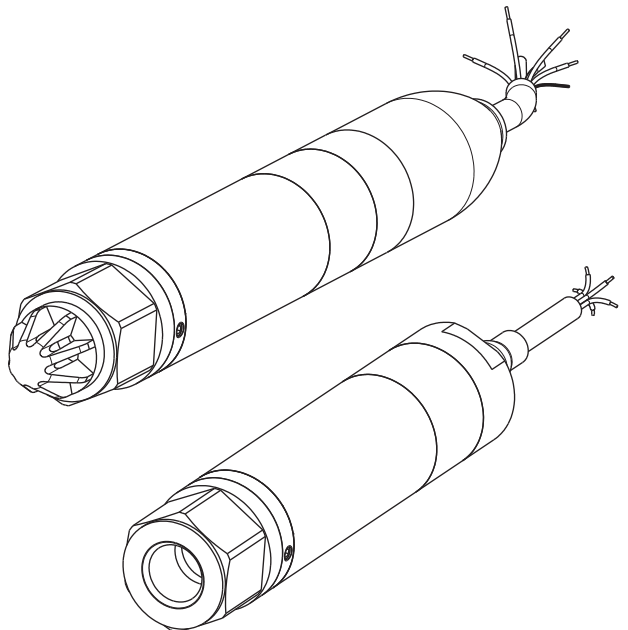

Safety



WARNING Do not use with media that has an oxygen concentration > 21 % or other strong oxidizing agents.

This product contains materials or fluids that may degrade or combust in the presence of strong oxidizing agents.

Do not apply pressure greater than the maximum safe working pressure to the sensor.

The manufacturer has designed this sensor to be safe when operated using the procedures detailed in this manual. Do not use this sensor for any other purpose than that stated.

This publication contains operating and safety instructions that must be followed for safe operation and to maintain the sensor in a safe condition. The safety instructions are either warnings or cautions issued to protect the user and the equipment from injury or damage.

Use qualified¹ personnel and good engineering practice for all procedures in this publication.

Maintenance

The sensor must be maintained using the manufacturer's procedures and these should be carried out by authorized service agents or the manufacturer's service departments.





<https://druck.com/service>

Technical Advice

For technical advice contact the manufacturer.

1. A qualified technician must have the necessary technical knowledge, documentation, special test equipment and tools to carry out the required work on this equipment.

Symbols

Symbol	Description
	This equipment meets the requirements of all relevant European safety directives. The equipment carries the CE mark.
	This equipment meets the requirements of all relevant UK Statutory Instruments. The equipment carries the UKCA mark.
	This symbol, on the equipment, indicates a warning and that the user should refer to the user manual.
	<p>Druck is an active participant in the UK and EU Waste Electrical and Electronic Equipment (WEEE) take-back initiative (UK SI 2013/3113, EU directive 2012/19/EU).</p> <p>The equipment that you bought has required the extraction and use of natural resources for its production. It may contain hazardous substances that could impact health and the environment.</p> <p>In order to avoid the dissemination of those substances in our environment and to diminish the pressure on the natural resources, we encourage you to use the appropriate take-back systems. Those systems will reuse or recycle most of the materials of your end life equipment in a sound way. The crossed-out wheeled bin symbol invites you to use those systems.</p> <p>If you need more information on the collection, reuse, and recycling systems, please contact your local or regional waste administration.</p> <p>Please visit the link below for take-back instructions and more information about this initiative.</p>
	
https://druck.com/weee	

Abbreviations

The following abbreviations are used in this manual.

Note: Abbreviations are the same in the singular and plural.

Abbreviation	Description
ADC	Analogue to Digital Converter
ASCII	American Standard Code for Information Interchange
°C	Degrees Celsius
cm	Centimetres
COSHH	Control of Substances Hazardous to Health
CRC	Cyclical Redundancy Checking
FS	Full-scale

Abbreviation	Description
ft	Feet
m	Metres
mA	Milli Ampere
mbar	Millibar
ms	Milli Second
mV	Milli Volt
N/A	Not Applicable
PC	Personal Computer
psi	Pound per square inch
R/W	Read/Write Access
RX	Receive
SDI-12	Serial Data Interface Communication Protocol
TX	Transmit
USB	Universal Serial Bus
V	Volt

Contents

1.	Introduction	1
1.1	Manufacturer	1
2.	Description	1
2.1	Purpose	1
2.2	Technical Specifications	1
2.3	Design and Principle of Operation	1
3.	Installation & Operation	2
3.1	General Requirements	2
3.2	Safety Measures	2
3.3	Connecting to a Pressure Source	3
3.3.1	Media Compatibility	3
3.3.2	Pressure Containment	4
3.4	Power Requirements	4
3.5	Connecting to SDI-12 Network	4
3.6	Maintenance	5
3.6.1	Visual Inspection	5
3.6.2	Cleaning	5
3.6.3	Adjustment	6
3.7	Returned Goods Procedure	6
3.7.1	Safety Precautions	6
3.7.2	Important Notice	6
3.8	Electromagnetic Compatibility	6
3.8.1	Power Supply and Metering	6
3.8.2	Cable Type	6
3.8.3	Earthing	7
3.9	Faults	7
4.	Programming Guide	7
4.1	SDI-12 Introduction	7
4.1.1	Typical Measurement Sequence	7
4.1.2	Baud Rate and Byte Frame Format	8
4.1.3	Allowable Data Characters	8
4.2	Transducer Address	8
4.3	Command Structure	8
4.4	Command Overview	9
4.4.1	Transducer Identification	9
4.4.2	Transducer Measurement	9
4.4.3	Average Filter Setup	9
4.4.4	Setting Liquid Density	10
4.4.5	Setting Gain and Offset	11
4.4.6	Tare	12
4.5	Command Set	13
4.5.1	Basic Command Set	13
4.5.2	Extended Command Set	14
	Appendix A. Register Table	15

1. Introduction

This manual is applicable to DPS5000 pressure transducers with the SDI-12 communications protocol.

The original language of this manual is English.

1.1 Manufacturer

The identified manufacturer of this equipment is:

“Druck Limited”

Fir Tree Lane, Groby, Leicester, LE6 0FH, United Kingdom.

Telephone: +44 116 231 7100; Fax: +44 116 231 7103

Internet: <https://druck.com>

2. Description

2.1 Purpose

The DPS5000 pressure transducers is a micro-controller based smart pressure transducer that provides a digital output through an SDI-12 interface. The transducer is a sealed device with the electrical connections made via an integral cable.

The DPS5000 pressure transducers is a low powered device offering a high level of accuracy over a wide temperature range. The SDI-12 interface provides compensated pressure and temperature readings and allows the transducer operation to be software controlled.

The transducers are of a modular design, the parameters of which are chosen by the customer at the time of order.

2.2 Technical Specifications

Refer to the appropriate DPS5000 data sheet for technical specifications and explanation of the transducer’s model number.

Model numbers appended with a four or eight-digit alphanumeric string denote the use of a customer-specific specification drawing indicating the use of additions or deviations to the data sheet specification. Refer to the specification drawing if applicable.

2.3 Design and Principle of Operation

The transducer consists of a pressure connector, pressure measuring module, a partially encapsulated electronics module, and electrical connection facilities, structurally combined in a cylindrical metal housing.

The pressure connector allows the transducer to be mounted to a pressurized vessel or pipework.

The pressure measuring module consists of a welded metal construction, featuring a metal diaphragm (providing a flexible barrier to harsh process media), a glass-to-metal seal (for electrical connections) and a fluid filled cavity containing a silicon-based micro-machined structure.

3. Installation & Operation



WARNING High pressures, temperatures and potentially poisonous pressure media are dangerous, and can cause injury to personnel and damage to property and the environment. Ensure correct installation, sealing of pressure interfaces and connection of the equipment. Ensure correct operation of the equipment in accordance with the specification. Use the applicable protection and obey all safety precautions.



CAUTION Until installation, keep the unit in the original container with all the covers in position. The container and covers prevent contamination and damage. When not in use, keep the connections clean at all times, and put the covers on the open connections.

3.1 General Requirements

When the transducer is received, check for completeness.

To identify the electrical and pressure connections, refer to the product data sheet or, if applicable, the specification drawing.

Do not use force when installing the transducer. Do not tighten the transducer by rotating the housing. For this purpose, a hexagon socket for the wrench is provided on the housing.

The ambient temperature and the process media to be measured must not exceed the ranges specified in the transducer specification.

In the negative temperature range it is necessary to exclude the accumulation and freezing of condensate in the working chambers and inside the connecting pipelines for gaseous media and freezing, crystallization of the medium or crystallization from it, of the individual components for liquid media.

The materials used for the primary enclosure and pressure bearing surfaces are identified in the product data sheet or, if applicable, the specification drawing. Make sure that the materials are applicable for the installation.

Before using the equipment, remove the plastic/rubber protection cap from the pressure connector.

The DPS5000 is a harsh media isolated product. Isolation is achieved by hermetically sealing the transducer element in an oil filled chamber. The weight of this oil gives a g sensitivity as a pressure offset error.

Note: The g-sensitivity will also create an error in a high vibration environment and the unit should be mounted accordingly.

3.2 Safety Measures

The operation of transducers in systems whose pressure may exceed the overload values specified in the data sheet or customer-specific specification drawing is not allowed.

Connection and detachment of transducers from the mains supplying the pressure of the medium to be measured must be done after the shutoff valve is closed from the process and the pressure in the working chamber is made equal to atmospheric.

The connecting pipes must have a one-way slope (not less than 1:10) from the pressure collection point up to the transducer, if the medium to be measured is gas, and down to the transducer if the medium is liquid. If this is not possible, when measuring gas pressure at the lower points of the connecting lines, it is necessary to install sludge vessels, and when measuring the liquid pressure at the highest points, install gas collectors.

Selected devices for mounting transducers should be mounted on straight sections, at the maximum possible distance from pumps, locking devices, elbows, expansion joints and other

hydraulic devices. It is especially not recommended to install transducers in front of the shut-off device if the medium to be measured is liquid. If there are water hammer effects in the system, it is recommended to use a transducer complete with a hydraulic shock dampener.

To reduce the temperature acting on the isolation diaphragm when measuring vapor pressure, it is recommended to use impulse tubes. The impulse tube must first be filled with water.

Attach the equipment in a safe configuration that prevents unwanted stress (vibration, physical impact, shock, mechanical and thermal stresses). Do not install the equipment where it can be damaged by a material that causes corrosion. Provide additional protection for the equipment if it may be damaged in service.

When installing power supply and signal wiring, the possibility of condensate entering the transducer cable entry should be avoided.

3.3 Connecting to a Pressure Source

When mounting the transducer, seal the mating surfaces. Failure to properly seal may affect performance or calibration accuracy.

Male threaded pressure connectors must not be sealed or constrained against the face at the base of the thread. The forward cone or flat face should always be used as indicated below.

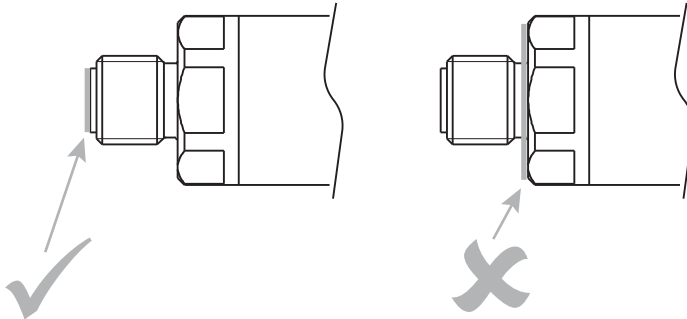

3.3.1 Media Compatibility

The media compatibility of the transducers is shown in Table 1.

Table 1: Media Compatibility

Product Material	Media Compatibility ^a
Stainless Steel	Fluids compatible with stainless steel 316L and Hastelloy C276.
Titanium	Fluids compatible with titanium grades 2 and 4.

a. Depth versions require compatibility with Hytrel, or polyurethane.

Note: Fluid classification complies with European Regulation (EC) No 1272/2008. Statements comply with European Pressure Equipment Directive 2014/68/EU. Refer to document K0581 for product classification and regulatory information.

3.3.2 Pressure Containment

The pressure containment of the transducers is shown in Table 2.

Table 2: Pressure Containment

Version	Pressure Range	Pressure Containment
Absolute	0 to 70 bar	200 bar maximum
	0 to 1015 psi	2900 psi maximum
Gauge	0 to 70 bar	6 x Full-scale up to 200 bar maximum
	0 to 1015 psi	6 x Full-scale up to 2900 psi maximum
Barometric	0.344 to 1.3 bar	200 bar maximum
	5.0 to 18.9 psi	2900 psi maximum
Hyperbaric (Depth)	0 to 45 bar	45 bar maximum (~450 m of water)
	0 to 650 psi	650 psi maximum (~1475 ft of water)

3.4 Power Requirements

The transducer should be connected to a SDI-12 compliant stable power supply. The power supply must be energy-limited to a maximum of 5 A. The power supply requirements for the transducer are shown in Table 3.

Table 3: Power Supply Requirements

Parameter	Value
Supply Voltage	6 to 30 V
	12 V nominal
Supply Current	10 mA nominal
	< 15 mA peak
	< 50 µA sleep

3.5 Connecting to SDI-12 Network

The figures below show example connections of the DPS5000 pressure transducer to a SDI-12 network. Figure 1 shows the pressure transducers receiving power from the data recorder.

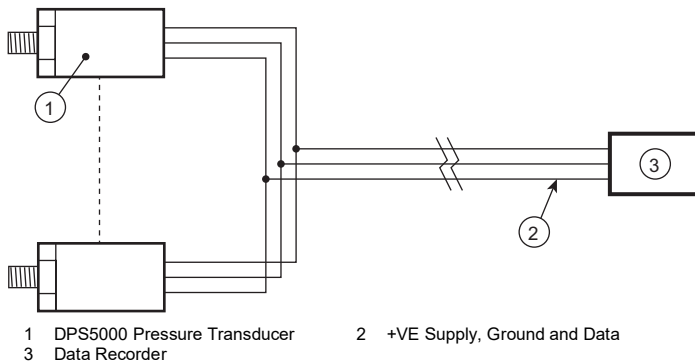

Figure 1: Connection with Data Recorder Providing Power

Figure 2 shows the pressure transducers receiving power from individual power supplies. The power supplies may be battery packs. If battery packs are used, ensure the transducer supply voltage stays within the operating limits in Table 3 on page 4.

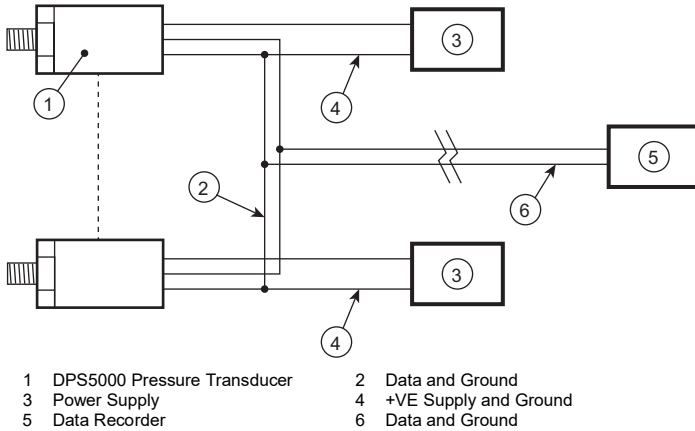

Figure 2: Connection with External Power Supplies

Table 4: DPS5000 Cable Color Identification

Color ^a	Name	Function
Red	+VE Supply	+12 V power supply.
Blue	Ground	Ground return for power supply.
White	Data	SDI-12 serial data.
Black	Case	Connected to pressure transducer body tube.
Screen	Screen	Cable screen, connected to pressure transducer body tube.

a. Any other conductor colors in the cable are unconnected.

3.6 Maintenance



WARNING High pressures and temperatures are dangerous and can cause injury (Refer to pressure limits in the sales data sheet). Be careful when working on components connected to lines that have high pressures and heat. Use the applicable protection and obey all safety precautions.

3.6.1 Visual Inspection

Inspect the product for damage and corrosion. Any damage to the product must be assessed. If the housing is no longer sealed against water and/or dust, the product must be replaced.

3.6.2 Cleaning

Clean the case with a damp lint-free cloth and mild detergent.

If the product has been in contact with hazardous or toxic materials, obey all the applicable Control of Substances Hazardous to Health (COSHH) or Material Safety Data Sheet (MSDS) references and precautions when handling.

3.6.3 Adjustment



WARNING Output Calibration, Full-Scale and Offset adjustment may be subject to state requirements for verification of metrological equipment.

For some models, the Output Calibration, Full-Scale and Offset settings can be adjusted. For instructions see Chapter 4., “Programming Guide,” on page 7.

Note: Druck can provide a calibration service that is traceable to international standards.

3.7 Returned Goods Procedure

To repair or calibrate the transducer, return it to the applicable Druck Service Department.

Please contact our Service Department, and get a Return Authorization number.

Please supply these details:

- Product (e.g. DPS5000 Pressure Transducer)
- Pressure range
- Serial number
- Details of defect / work to be undertaken
- Calibration traceability requirements
- Operating conditions

3.7.1 Safety Precautions

To prevent possible injury when we receive the product, you must also tell us if the product has been in contact with hazardous or toxic materials. Please supply the applicable Control of Substances Hazardous to Health (COSHH) or Material Safety Data Sheet (MSDS) references and precautions.

3.7.2 Important Notice

Service or calibration by unauthorized sources will affect the warranty and may not guarantee further performance.

3.8 Electromagnetic Compatibility

The pressure transducer complies with the European Electromagnetic Compatibility Directive 2014/30/EU.

3.8.1 Power Supply and Metering

The quality of the power supply and monitoring equipment will directly affect the EMC performance of the entire system. Since “Druck Limited” has no control over the installation of the transducer it must remain the responsibility of the user to ensure that the EMC performance of the system is adequate.

To maintain good immunity from electromagnetic disturbances present on the system power supply, the power supply should filter any transient interference from the incoming line and present a clean regulated DC supply to the transducer. The monitoring equipment should likewise be immune from the effects of electromagnetic disturbances and not impart disruptive signals on the connections to the transducer.

The transducer is not intended for connection to a DC distribution network.

3.8.2 Cable Type

Due to the small size of the transducer it is unlikely to be directly affected by radiated RF energy. Any RF energy that gets into the circuit will probably enter via the interconnecting cable.

To minimize the effect of nearby circuits and events, it is necessary to use screened cable between the transducer and power supply / monitoring equipment. Failure to do so will invalidate the EMC tests conducted by "Druck".

The choice of cable type should reflect the environment through which it is going to run. Screened cable should always be used where electrical noise is present. Good cabling practice will be reflected in signal quality.

3.8.3 Earthing

For the screening of the cable to be effective, it is essential that the screen or drain conductor is permanently bonded to earth (ground). This should take place at the monitoring end of the cable as close to the power supply as practical. Protection should be afforded to any unscreened section of cable or circuit by means of a screened enclosure. Take care not to create ground loops.

3.9 Faults



WARNING Risk of injury to personnel and damage to property and the environment.

In the event of a fault:

- Establish if the pressure transducer is mounted, sealed, connected and programmed correctly as instructed.
- Contact the manufacturer for further advice on fault elimination.
- For persistent faults, safely remove the equipment from service. Refer to Section 3.7 for returned goods procedure.

4. Programming Guide

This section introduces the SDI-12 communication protocol and the DPS5000 measurement procedure.

4.1 SDI-12 Introduction

SDI-12 is a standard for interfacing data recorders with microprocessor-based transducers. This section will discuss commands and how to use them.

4.1.1 Typical Measurement Sequence

SDI-12 data recorders and transducers communicate by an exchange of ASCII characters on the data line. A typical data recorder/transducer measurement sequence proceeds as follows:

1. The data recorder wakes all transducers from low-power standby mode on the SDI-12 bus with a break. A break is continuous spacing (binary 0) on the data line for at least 12 ms.
2. The data recorder transmits a command to a specific transducer address, instructing it to make a measurement.

Note: Other transducers on the SDI-12 bus ignore the command and return to low-power standby mode.

3. The addressed transducer responds within 15 ms, with the following data:
 - i. The maximum time needed until the measurement data will be ready.
 - ii. The number of data values the transducer will return.
4. If the measurement is immediately available, the data recorder transmits a command to the transducer instructing it to return the measurement(s). If the measurement is not ready, the data recorder waits for the transducer to send a request to the recorder, which indicates that

the data is ready. The data recorder then transmits a command to the transducer to retrieve the measurement data.

Note: When a data recorder tells a transducer to start its measurement procedure, the data recorder does not communicate with any other transducer until the data collection from the first transducer is complete.

5. The transducer responds, returning the measurement.

4.1.2 Baud Rate and Byte Frame Format

SDI-12 data recorders and transducers communicate by an exchange of ASCII characters on the data line. See Table 5 for the SDI-12 byte frame format.

Table 5: Baud Rate and Byte Frame Format

Parameter	Value
Baud rate	1200
Start bits	1
Data bits	7, least significant bit transmitted first
Parity bit	1, even parity
Stop bits	1

4.1.3 Allowable Data Characters

All characters transmitted on the SDI-12 bus must be printable ASCII characters from 32 decimal to 126 decimal, except for the following exceptions:

1. All responses from a SDI-12 transducer with a carriage return (0D hex, 13 decimal) and a line feed (0A hex, 10 decimal) character.
2. In some cases the second and third character of a CRC code may not be printable ASCII characters.

4.2 Transducer Address

The first character of every command is the transducer address. This lets the SDI-12 data recorder verify that the response has come from the correct transducer. See Table 6 for address codes.

Table 6: transducer Address

Address		Description
ASCII	Decimal	
0 (zero)	48	Default address, all transducers are initially set to "0" (zero) by the manufacturer for use in single transducer systems.
1 to 9	49 to 57	Addresses for additional transducers on the SDI-12 bus.
?	63	When a "?" is used as the address character, a transducer will respond irrespective of its own address. This addressing method should not be used if more than one transducer is connected to the SDI-12 bus. If more than one transducer is connected to the bus, they will all respond, causing a bus contention.

4.3 Command Structure

Each command is an ASCII string with up to 5 characters, starting with the transducer address and end by a "!" character.

4.4 Command Overview

All responses from the transducer end with a carriage return (0D hex, 13 decimal) and a line feed (0A hex, 10 decimal) character.

4.4.1 Transducer Identification

To request the transducer identification, the data recorder transmits the transducer identification command "a!" to the addressed transducer. The transducer replies back with the transducer identification. Example data transmission sequence below:

TX/RX	Command ^a	Description
TX>	a!	Transducer identification command.
RX>	a13DruckLtdDPS5XE1.012345678	"13" is SDI-12 protocol version 1.3. "DruckLtd" is manufacturer's name. "DPS5XE" is model name, e.g. DPS50#E or DPS5T#E. "1.0" is transducer version, i.e. 1.0. "12345678" is serial number. This may be a 7 or 8-digit number.

a. The first letter 'a' in the command is replaced by the transducer address, see Section 4.2.

4.4.2 Transducer Measurement

To request a transducer measurement, the data recorder transmits the start measurement command "aM!" to the addressed transducer. The transducer replies back when the measurements will be ready and how many measurements it has taken. The data recorder waits for the transducer to be ready and transmits the send data command "aD0!". The transducer replies back with the measurement data. Example data transmission sequence below:

TX/RX	Command ^a	Description
TX>	aM!	Start measurement command.
RX>	a0013	3 values ready after 1 second.
TX>	aD0!	Send data command.
RX>	a<value1><value2><value3>	<value1> is compensated pressure. <value2> is compensated temperature. <value3> is density compensated level.

a. The first letter 'a' in the command is replaced by the transducer address, see Section 4.2.

4.4.3 Average Filter Setup

This filter takes an average of a specified number of measurements taken over a specified period. The pressure transducer can also report the statistical values of the measurement samples during the measurement period. The filter setup requires the time between measurements (SampleInterval) and the total number of measurements (SampleWindow) to be averaged.

Note: The average filter register table settings can only be modified when the pressure transducer is in customization mode. See the "aXMW" command in Section 4.5.2.

The example below shows a typical average filter setup and the communication sequence with the pressure transducer.

SampleWindow = 10 (total samples)

SampleInterval = 60 (seconds)

Note: The product of SampleWindow x SampleInterval must be less than 999.

TX/RX	Command ^a	Description
TX>	aXMW1<password>!	Enter into customization mode.
RX>	a	Acknowledgment from pressure transducer.
TX>	aXSW710!	Set SampleWindow to 10.
RX>	a10	Acknowledgment from pressure transducer.
TX>	aXSW860!	Set SampleInterval to 60.
RX>	a60	Acknowledgment from pressure transducer.
TX>	aXSF!	Commits all values in the register table to the power-on defaults.
RX>	a	Acknowledgment from pressure transducer.

a. The first letter 'a' in the command is replaced by the transducer address, see Section 4.2.

Reset the pressure transducer to exit the customization mode. The pressure transducer now powers-up with the above average filter setup. Below shows the start measurement communication sequence with the pressure transducer with the average filter setup.

TX/RX	Command ^a	Description
TX>	aM!	Start measurement command.
RX>	a6008	8 values ready after 600 seconds. (10 x 60 = 600 seconds)
TX>	aD0!	Send data command.
RX>	a<value1><value2><value3>	<value1> is compensated pressure. <value2> is compensated temperature. <value3> is density compensated level.
TX>	aD1!	Send data command.
RX>	a<value1><value2><value3>	<value1> is mean pressure. <value2> is pressure variance. <value3> is pressure standard deviation.
TX>	aD2!	Send data command.
RX>	a<value1><value2>	<value1> is maximum pressure. <value2> is minimum pressure.

a. The first letter 'a' in the command is replaced by the transducer address, see Section 4.2.

Note: Setting SampleWindow to 1 turns off the average filter. The pressure transducer will only reply with 3 readings, see example in Section 4.4.2.

4.4.4 Setting Liquid Density

The level measurement depends on knowing the density of the liquid it is in. The pressure transducer AverageDensity register entry holds the average density of the liquid used in the level measurement calculation. The default AverageDensity entry is 1.0 kg/m³, which is the density of pure water.

Note: Temperature compensation of the level measure is only performed when AverageDensity = 1.0. Changing AverageDensity to any other value results in the loss of temperature compensation of the level measurement.

The example below shows how to change the average density to that typical of sea water.

TX/RX	Command ^a	Description
TX>	aXMW1<password>!	Enter into customization mode.
RX>	a	Acknowledgment from pressure transducer.
TX>	aXSWA1.0236!	Set AverageDensity to 1.0236. The value must be positive and in the units of kg/m ³ .
RX>	a1.0236	Acknowledgment from pressure transducer.
TX>	aXSF!	Commits all values in the register table to the power-on defaults.
RX>	a	Acknowledgment from pressure transducer.

a. The first letter 'a' in the command is replaced by the transducer address, see Section 4.2.

Reset the pressure transducer to exit the customization mode. The pressure transducer now powers-up with the above average density setup.

4.4.5 Setting Gain and Offset

The pressure and temperature measurements allow for additional gain and offset adjustment. Note that changing these values does not effect the calibration data stored within the pressure transducer. The gain and offset are applied with the following equation:

$$\text{Output} = (\text{Measurement} \times \text{Gain}) + \text{Offset}$$

The following example shows gain and offset being applied to the pressure measurement:

TX/RX	Command ^a	Description
TX>	aXMW1<password>!	Enter into customization mode.
RX>	a	Acknowledgment from pressure transducer.
TX>	aXSW01.12!	Set PressureGain to 1.12.
RX>	a1.12	Acknowledgment from pressure transducer.
TX>	aXSW10.005!	Set PressureOffset to 0.005 bar. The pressure offset is always defined in bar, irrespective of the current pressure units.
RX>	a0.005	Acknowledgment from pressure transducer.
TX>	aXSF!	Commits all values in the register table to the power-on defaults.
RX>	a	Acknowledgment from pressure transducer.

a. The first letter 'a' in the command is replaced by the transducer address, see Section 4.2.

Reset the pressure transducer to exit the customization mode. The pressure transducer now powers-up with the above pressure gain and offset setup.

The following example shows gain and offset being applied to the temperature measurement:

TX/RX	Command ^a	Description
TX>	aXMW1<password>!	Enter into customization mode.
RX>	a	Acknowledgment from pressure transducer.
TX>	aXSW20.98!	Set TemperatureGain to 0.98.
RX>	a0.98	Acknowledgment from pressure transducer.
TX>	aXSW30.15!	Set TemperatureOffset to 0.15 °C. The temperature offset is always defined in Celsius, irrespective of the current temperature units.
RX>	a0.15	Acknowledgment from pressure transducer.
TX>	aXSF!	Commits all values in the register table to the power-on defaults.
RX>	a	Acknowledgment from pressure transducer.

a. The first letter 'a' in the command is replaced by the transducer address, see Section 4.2.

Reset the pressure transducer to exit the customization mode. The pressure transducer now powers-up with the above temperature gain and offset setup.

4.4.6 Tare

The Tare value is subtracted from the pressure measurement in the measurement units. The Tare function has the following equation.

$$\text{Output} = \text{Measurement} - \text{Tare}$$

The example below shows how to change the Tare value.

TX/RX	Command ^a	Description
TX>	aXMW1<password>!	Enter into customization mode.
RX>	a	Acknowledgment from pressure transducer.
TX>	aXSWB0.25	Set Tare to 0.25. This will cause the pressure measurement to have 0.25 subtracted from it.
RX>	a0.25	Acknowledgment from pressure transducer.
TX>	aXSF!	Commits all values in the register table to the power-on defaults.
RX>	a	Acknowledgment from pressure transducer.

a. The first letter 'a' in the command is replaced by the transducer address, see Section 4.2.

4.5 Command Set

4.5.1 Basic Command Set

Command	Response	Description
?!	a	Address query.
0Aa!	a	Change transducer address from '0' to 'a'.
a!	allccccccmmmmmmvvvxxx...xxx	Send identification. "ll" is SDI-12 protocol version number. "ccccccc" is manufacturer's name. "mmmmmm" is model name. "vvv" is transducer version. "xxx...xxx" is serial number. (See example in Section 4.4.1)
aV!	att1	1 value ready after ttt seconds.
aD0!	a<value>	<value> is checksum value of code area.
aM!	att3	3 values ready after ttt seconds. (Average filter is turned off)
aD0!	a<value1><value2><value3>	<value1> is compensated pressure. <value2> is compensated temperature. <value3> is density compensated level.
aM!	att8	8 values ready after ttt seconds. (Average filter is turned on, see Section 4.4.3)
aD0!	a<value1><value2><value3>	<value1> is compensated pressure. <value2> is compensated temperature. <value3> is density compensated level.
aD1!	a<value1><value2><value3>	<value1> is mean pressure. <value2> is pressure variance. <value3> is pressure standard deviation.
aD2!	a<value1><value2>	<value1> is maximum pressure. <value2> is minimum pressure.
aM1!	att1	1 value ready after ttt seconds.
aD0!	a<value>	<value> is compensated pressure.
aM2!	att1	1 value ready after ttt seconds.
aD0!	a<value>	<value> is compensated temperature.
aM3!	att1	1 value ready after ttt seconds.
aD0!	a<value>	<value> is density compensated level.
aM4!	att2	2 values ready after ttt seconds.
aD0!	a<value1><value2>	<value1> is pressure ADC raw value. <value2> is temperature ADC raw value.
aM5!	att2	2 values ready after ttt seconds.
aD0!	a<value1><value2>	<value1> is pressure mV value. <value2> is temperature mV value.

Command	Response	Description
aMC! aMC1! ~ aMC5!	Same as M command above, but with additional CRC value added.	
aC! aC1! ~ aC5!	Same as M command above, but the measurement is not cancelled if there is a request on the data line before the measurement is ready.	
aCC! aCC1! ~ aCC5!	Same as C command above, but with additional CRC value added.	

4.5.2 Extended Command Set

Command	Response	Description
aXSR<index>!	a<value>	Reads the value in the register table at the specified index. See Table A-1 on page 15. This command is only available when the pressure transducer is in customization mode.
aXSW<index><value>!	a<value>	Writes the specified value to the register table at the specified index. See Table A-1 on page 15. This command is only available when the pressure transducer is in customization mode.
aXSF!	a	Commits all values in the register table to the power-on defaults. See Table A-1 on page 15. This command is only available when the pressure transducer is in customization mode.
aXSFF<direction>!	a	Copies register table values to/from the customer and factory storage area. 0: copies values from customer area to factory area. 1: copies values from factory area to customer area. This command is only available when the pressure transducer is in customization mode.
aXMW<mode><password>!	a	Changes the operation mode of the pressure transducer. <mode> is the index value of the specified mode. <password> is used to authorize access. See Table A-5 on page 16.

Appendix A. Register Table

Table A-1: Register Table Entries

Index	Name	R/W	Type	Description
0	PressureGain	R+W	float	Gain value of pressure, default is 1. Range from -2.0 to +2.0.
1	PressureOffset	R+W	float	Offset value of pressure, default is 0. The value is in bar pressure units.
2	TemperatureGain	R+W	float	Gain value of temperature, default is 1. Range from -2.0 to +2.0.
3	TemperatureOffset	R+W	float	Offset value of temperature, default is 0. The value is in Celsius.
4	PressureUnit	R+W	uint8	Pressure value unit, default is 1, bar. See Table A-2.
5	TemperatureUnit	R+W	uint8	Temperature value unit, default is 1, Celsius. See Table A-3.
6	LevelUnit	R+W	uint8	Level value unit, default is 0, metres. See Table A-4.
7	SampleWindow	R+W	uint16	Total sample number for statistic value, default is 1. For values greater than 1, the time of response for aM! is window x interval.
8	SampleInterval	R+W	uint8	Time between two samples, in seconds, default is 1. The product of window x interval should be no larger than 999.
9	Gravity	R+W	float	Gravity value. Default is 9.8. Range from 9.0 to 10.0.
A	AverageDensity	R+W	float	Average density of the liquid. Default is 1.0. In default case, the system would regard it as pure water and density temperature compensation is triggered on auto. The value must be positive and in the units of kg/m ³ .
B	Tare	R+W	float	The tare value that should be removed from pressure measurement in current measurement units. The default value is 0.0.

Table A-2: Pressure Unit Codes

Pressure Code	Units
0	mbar
1	bar
2	hPa
3	kPa
4	MPa
5	psi
6	mmH ₂ O

Table A-2: Pressure Unit Codes

Pressure Code	Units
7	inH ₂ O
8	ftH ₂ O
9	mH ₂ O
10	mmHg
11	inHg
12	kgf/cm ²
13	atm

Table A-3: Temperature Unit Code

Temperature Code	Units
0	Kelvin
1	Celsius
2	Fahrenheit

Table A-4: Level Unit Code

Level Code	Units
0	m
1	cm
2	ft

Table A-5: Operation Mode Register

Index	Name	Password	Description
0	Normal	N/A	Default value for pressure transducer after power-on or reset.
1	Customization	N/A	In customization mode, it is possible to configure the register values in Table A-1. The pressure transducer returns to normal mode after a reset.

Office Locations



<https://druck.com/contact>

Services and Support Locations



<https://druck.com/service>