

RV Series Pressure Relief Valves

Pressure relieving device for protection of pneumatic instrumentation

The **Becker™** RV Series Pressure Relief Valve is designed to be used with regulated natural gas supply systems that provide power to pneumatic valve actuators and instrumentation. In the event of supply gas regulator failure, the pressure relief valve protects pneumatic components from overpressure. Inexpensive, compact, and maintenance-free, the RV safety mechanism will ensure protection of your pneumatic actuators and instrumentation.

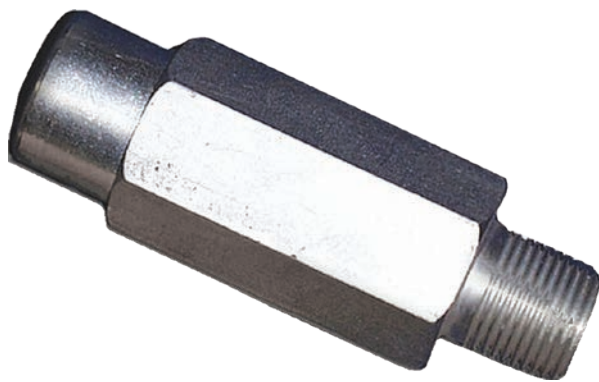

Figure 1 - RV Series Pressure Relief Valve

Usage

- Becker Model FD-1 Supply Gas Systems
- Becker Model FD-2 Supply Gas Systems
- Becker Model PIC Pressure Instrumentation Columns
- Becker Power Pack Supply Gas Systems

Compatibility

- Specifically designed for use with natural gas as the flow medium
- All Becker pneumatic instrumentation
- All Becker pneumatic valve actuators

How it Works

When the system pressure exceeds the setpoint of the RV, the relief valve seat opens slightly to vent excess pressure, protecting downstream components. When system pressure returns to normal, the RV closes, forming a bubble-tight seal.

Features

- The Becker RV pressure relief valve automatically resets to its original position, forming a bubble-tight seal
- Setpoint pressure of each RV is permanently stamped on the valve for easy reference
- For safety purposes the setpoint pressure is not field adjustable
- Extra-long guided spring provides excellent repeatability and accuracy
- Stainless steel construction
- Weather resistant, allowing for usage in outdoor stations
- Threaded outlet port allows RV exhaust to be ported to a vent system

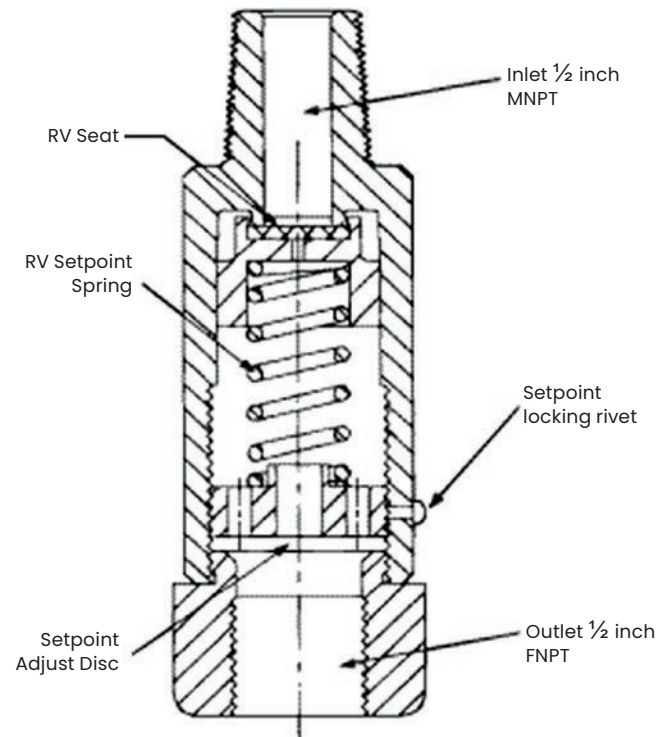

Figure 2 - RV Series Cross Sectional View

Specifications		
Weight:	0.8 lbs (0.36 kg)	
Dimensions:	See Figure 3	
Ports:	Inlet: 1/2 inch MNPT Outlet: 1/2 inch FNPT	
Operating Temperature:	-30°F to 160°F (-34°C to 71°C)	
Materials of Construction:	Body:	Stainless steel
	Spring:	Stainless steel
	Seat Disc:	Buna-N

Set Pressure psig (barg)	Part Number
25 (1.72)	04-2522
40 (2.76)	04-2559
50 (3.45)	04-2556
60 (4.14)	04-2565-ADJ-60
70 (4.83)	04-2565-ADJ-70
80 (5.52)	04-2565-ADJ-80
90 (6.21)	04-2565-ADJ-90
100 (6.89)	04-2575
110 (7.58)	04-2565-ADJ-110
136 (9.38)	04-2565-ADJ-136
140 (9.65)	04-2565-ADJ-140
150 (10.3)	04-2512
160 (11.0)	04-2565-ADJ-160
200 (13.8)	04-2547
300 (20.7)	04-2548

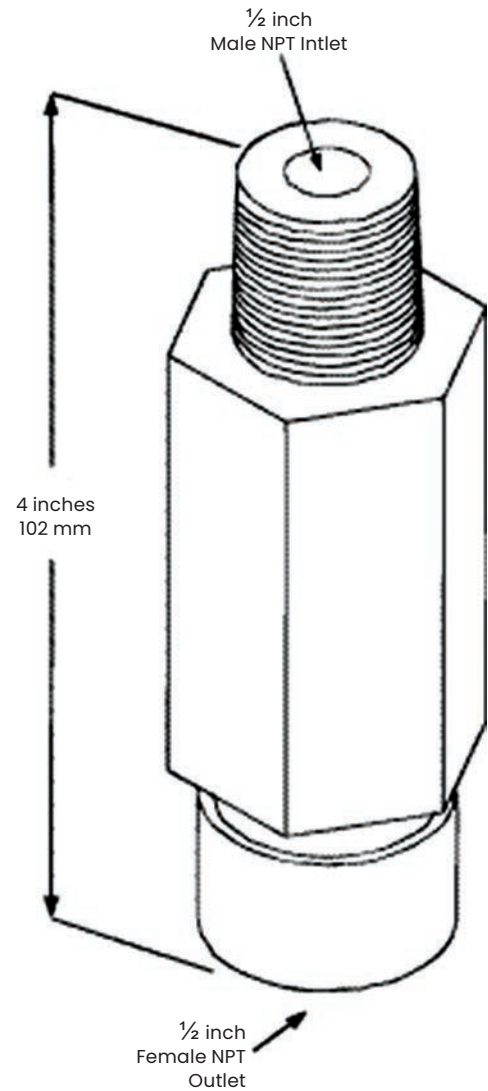

Figure 3 - RV Series Dimensions