

Consolidated™ 13900 Series

Pilot-Operated Safety Relief Valve

Designed specifically for high capacity steam applications, this series of valves contributes to the overall efficiency and profitability of plant operations.

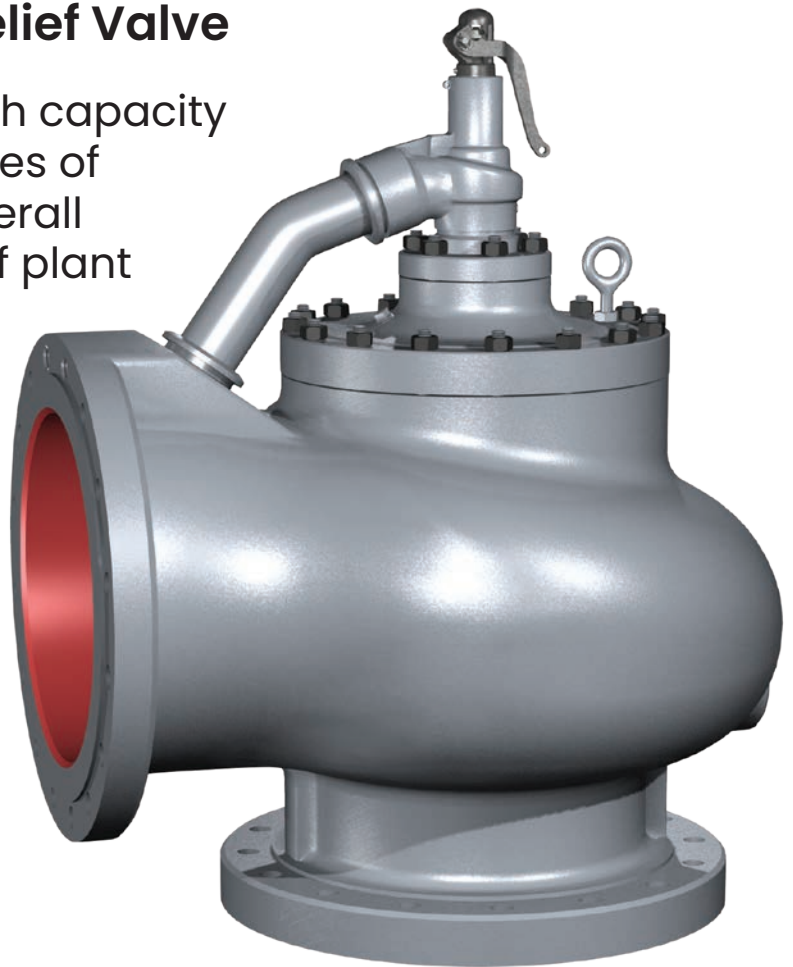

Table of Contents

Conversion Table	3
Features and Benefits	4
Applications.....	5
Scope of Design	5
Materials.....	6-8
Options	9
Dimensions and Weights.....	10
Capacities.....	11
Valve Configuration Code.....	12
Ordering a 13900 Series POSRV	13

Baker Hughes provides a full range of Consolidated pressure valve styles, sizes, options and configurations for multiple industries, applications, environments, and media. From spring-actuated to pilot-operated, each pressure valve is configured to offer safer process flow control in harsh environments.

Conversion Table

All the USCS values are converted to metric values using the following conversion factors:		
USCS Unit	Conversion Factor	Metric Unit
in.	25.4	mm
lb.	0.4535924	kg
in ²	6.4516	cm ²
ft ³ /min	0.02831685	m ³ /min
gal/min	3.785412	L/min
lb/hr	0.4535924	kg/hr
psig	0.06894757	barg
ft lb	1.3558181	Nm
°F	5/9 (°F-32)	°C

Features and Benefits

For system applications that require large discharge release capacities, the Consolidated 13900 Series Safety Relief Valve provides extremely reliable working economy and a simple efficient valve design. It also features a valve configuration that simplifies installation and in-line valve maintenance.

Greater Total System Efficiency

The main valve can handle extremely large relieving capacities, in excess of 3 million pounds of steam per hour (1,360,777 kg/hr). It has a seven-to-one discharge capacity over a "T" type orifice, and a two-to-one discharge capacity over a "W" type orifice.

Improved Design

The total valve external configuration is considerably smaller in size, and the valve is lighter in weight than a comparable spring-loaded valve. Because of these features, less space is required for valve installation.

A simple, efficient and reliable direct acting valve design with few components eliminates the need for excessive spare parts inventory and reduces maintenance time.

Easy Installation and Maintenance

Valve configuration is considerably smaller in size and lighter in weight than a comparable spring-loaded valve. This makes installation, field handling, testing, and valve maintenance easy.

Valve maintenance is relatively simple and straightforward. The simple valve design means fewer parts. Fewer valve parts mean that less can go wrong, malfunctions can be readily diagnosed, and maintenance costs and process downtime can be kept to a minimum.

To simplify valve maintenance, all main valve components can be removed through the top bonnet of the valve. The pilot valve can be field tested and repaired without breaking inlet and outlet piping connections on the main valve. The pilot valve opening and closing is easily adjusted on a small test facility.

Description

The 13900 Series Pilot-Operated Safety Valve is an ASME Section XIII (UV Designator)-approved valve intended for use on compressible fluids. The valve design is simple. It consists of a small conventional, fail-safe pilot safety valve and main valve.

Overcompression of the main valve seat O-ring, located between the disc and bushing, is eliminated by the metal-to-metal contact bearing surfaces between the disc and bushing. Removing the pressure from behind the O-ring via two small slots when the valve is open and flowing eliminates O-ring seal blowout. A condensate drain hole in the disc easily drains any accumulated moisture in the upper disc cavity.

The spring-loaded U-shaped PTFE guide seal provides increased seat tightness as system pressure increases. The PTFE material greatly reduces friction on the main disc and allows for reliable, dependable and repeatable disc action. The seal spring load ensures sealing at all times.

PTFE guide rings eliminate friction along with metal-to-metal contact between the disc and guide. Main valve disc action is repeatable and reliable.

The pilot valve action directly controls the pressure forces on the main valve disc and eliminates the need for a transfer valve. System pressure that actuates the pilot valve is transmitted through a simple, full-flow design sensing tube. The sensing tube eliminates small orifice control parts and their possible clogging characteristics and is enclosed within the valve body, which protects it from damage and freezing.

Pilot valve blowdown can be adjusted independently of the main valve and before the pilot valve is installed on the main valve.

The pilot valve disc is a metal-seated design that is easily serviced and provides a seat tightness to 95 percent of set pressure.

The main unloading valve has a large orifice of up to 200 in² (1290 cm²), which reduces the number of valves required for overpressure protection. This eliminates installation costs for additional header nozzles and exhaust lines.

The O-ring seat seal design and the spring-loaded PTFE rings assure tightness, valve integrity, and easy valve maintenance.

Applications

- The 13900 Series Pilot-Operated Safety Relief Valve is designed for steam applications where pressures range from 50 psig (3.45 barg) to 300 psig (20.68 barg) and temperatures range from 250°F (121°C) to 550°F (288°C). The temperature limit is applied to the valve to ensure that the PTFE seal rings will maintain sealing integrity.
- The 13900 Series Pilot-Operated Safety Relief Valve can be used on any compressible fluid within the pressure and temperature limits of the valve, provided the fluid media exhibits characteristics similar to saturated steam. For applications other than steam, the open lift lever cap should be reviewed for adequacy. If another cap design is required, it should be so stated.
- The 13900 Series Pilot-Operated Safety Relief Valve is available in four sizes, 114, 143, 176 and 200 in² (735, 923, 1135 and 1290 cm²).
- For all sizes except the 200 in² (1290 cm²), the largest possible relieving capacity is supplied for the valve inlet size specified.
- For those applications where discharge pressures at the valve outlet exceed 10 percent of the pilot valve set pressure, or where economics dictate that higher discharge pressures be required, the pilot valve can be exhausted separately and the discharge pressure of the main valve can be allowed to increase above the limit of 10 percent of the pilot valve set pressure.
- Typical valve applications include boiler feed pump turbines, flash tanks, steam lines and deaerator.



CAUTION

These valves are not to be used on power boilers.

Scope of Design

13900 Flanged Series Pilot-Operated Safety Relief Valve

Standard Valve Connections								
Valve Type	Orifice Area		Inlet			Outlet		
			Size		Pressure Class	Size		Pressure Class
	In ²	cm ²	In.	mm		In.	mm	
13906-114	114.000	735.480	16.00	406.4	300# R. F.	18.00	457.2	150# R. F. ⁽¹⁾
13906-143	143.100	923.220	18.00	457.2	300# R. F.	22.00	558.8	150# R. F. ⁽²⁾
13906-176	176.700	1140.000	20.00	508.0	300# R. F.	24.00	609.6	150# R. F.
13906-200	201.000	1296.770	20.00	508.0	300# R. F.	24.00	609.6	150# R. F.

1. The 22" (558.8 mm) 150# flange is not covered by ASME B16.5. Drilling is (20) 1.375" (34.93 mm) diameter holes on a 27.25" (692.2 mm) diameter bolt circle. Covered by MSS-SP-44.
2. Two holes on outlet drilling are tapped and threaded 1.125-7UNC-2B Thread, 1.5" (38.1 mm) deep.

Pressure/Temperature Limits								
Valve Type	Set Pressure				Temperature			
	min.		max.		min.		max.	
	psig	barg	psig	barg	°F	°C	°F	°C
All Sizes	50	3.44	300	20.68	250	121.1	550	287.7

Materials

13900 Type Main Valve

13900 Series Main Valve

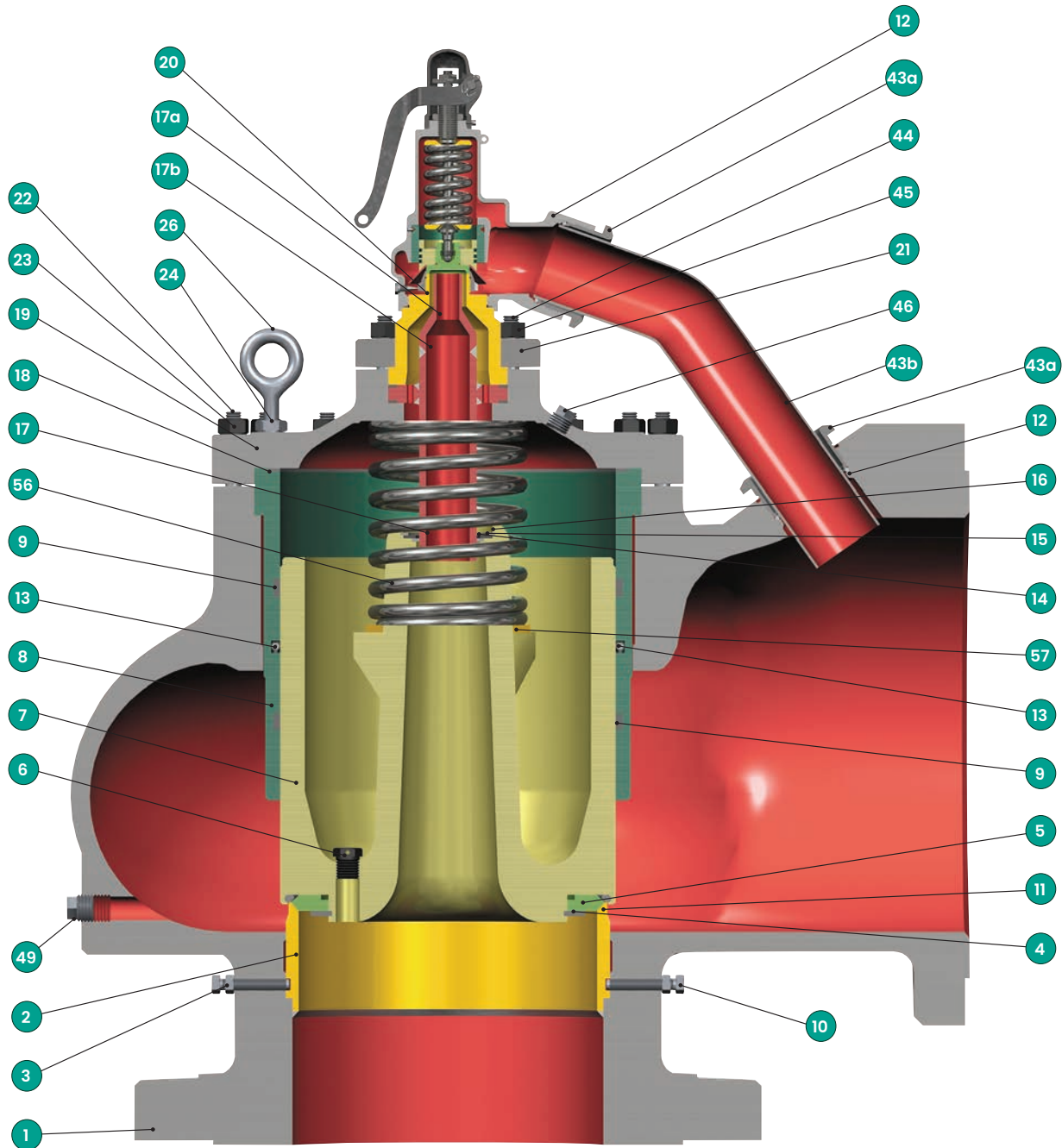

Materials

13900 Series Standard Materials

Standard Material for 13900 Series POSRV		
Ref. No.	Nomenclature	Material (-CC)
1	Main Base	ASME SA216 WCC CS
2	Seat Bushing	ASTM A451 CPF8M SSt.
3	Seat Bushing Ret. Scr. Jam Nut	Carbon Steel (Cadmium Plated)
4	Retainer Lock Ring	Carbon Steel (Nickel Plated)
5	O-ring Retainer	ASTM A240 410 ⁽¹⁾
6	Disc Drain Plug	316 Stainless Steel
7	Main Disc	ASTM A743 CA6NM SSt.
8	Main Guide	ASTM A743 CA15 SSt.
9	Back-up Ring	PTFE
10	Seat Bushing Retainer Screw	ASTM A582 416 ⁽¹⁾
11	O-ring Seat Seal	PTFE
12	Discharge Tube Fitting Seal	PTFE
13	Guide Seal	Virgin PTFE Cover ⁽²⁾
14	Floating Washer	ASTM A276 410 ⁽³⁾
15	Floating Washer Retainer	ASTM A276 410 ⁽³⁾
16	Fl. Washer Retainer Lock Ring	PH15-7 MO Stainless Steel
17	Sensing Tube Assembly	
17a	Upper Tube	ASME SA-479 316
17b	Lower Tube	ASTM A249 TP304 SSt.
17c	Tube Flange	ASTM A36 CS
18	Bonnet Gasket	ASTM A167 304 SSt. ⁽⁴⁾
19	Bonnet	ASME SA216 WCC CS
20	Pilot Base	ASME SA-479 316 SSt.
21	Pilot Base Flange	ASME SA105 Carbon Steel
22	Base Studs	ASTM A193 B7 Alloy Steel
23	Base Stud Nuts	ASTM A194 2H Carbon Steel
24	Eye Bolt Lock Nut	Carbon Steel
25	Pilot Bonnet Gasket	Soft Iron
26	Eye Bolt	Carbon Steel
27	Adjusting Ring Pin	ASTM A582 416 ⁽¹⁾
28	Adjusting Ring	ASTM A743 CA15 SSt.
29	Pilot Bonnet Assembly	
29a	Bonnet	ASME SA216 WCC CS
29b	Guide	ASTM A479 316L SSt.
29c	Pin	ASTM A479 304 SSt.

Standard Material for 13900 Series POSRV		
Ref. No.	Nomenclature	Material (-CC)
30	Bottom Spring Washer	ASTM A108 1018/19/20 CS
31	Spindle Assembly	
31a	Spindle	ASTM A108 1213 CS
31b	Spindle Collar	ASTM A276 410 ⁽³⁾
32	Top Spring Washer	ASTM A108 1018/19/20 CS
33	Lever	Malleable Iron
34	Compression Screw Lock Nut	ASTM A108 1018/19/20 CS
35	Release Nut	ASTM A276 410 ⁽³⁾
36	Release Lock Nut	Carbon Steel
37	Cap	ASTM A47 35018 ⁽⁵⁾
38	Lever Pin	Martensitic SSt.
39	Cap Lock Screw	Carbon Steel
40	Compression Screw	ASTM A582 416 ⁽³⁾
41	Spring	Inconel
42	Pilot Disc Assembly	
42a	Disc	ASTM A276 410 ⁽³⁾
42b	Disc Holder	ASME SA-479 316L SSt.
42c	Disc Collar	ASTM A167 304 SSt.
42d	Retainer Ring	PH15-7 MO Stainless Steel
43	Discharge Tube Assembly	
43a	Fitting	ASME SA105 Carbon Steel
43b	Discharge Tube	ASTM A106 Grade B CS
44	Bonnet Studs	ASTM A193 B7 Alloy Steel
45	Bonnet Stud Nuts	ASTM A194 2H Carbon Steel
46	Main Bonnet Plug	ASTM A182 F304 SSt.
47	Main Base Nameplate ⁽⁶⁾	Stainless Steel
48	Pilot Base Nameplate ⁽⁶⁾	Stainless Steel
49	Main base Drain Plug	ASTM A182 F304 SSt.
50	Main Base Nameplate Screws ⁽⁶⁾	Steel (Nickel Plated)
51	Pilot Base Nameplate Screws ⁽⁶⁾	Steel (Nickel Plated)
52	Sensing Tube Flange Gasket	ASTM A167 304 SSt. ⁽⁴⁾
53	Adjusting Ring Pin Gasket	Soft Iron
54	Seal ⁽⁶⁾	Aluminum
55	Seal Wire ⁽⁶⁾	Steel
56	Disc Spring (Main Valve)	Inconel X-750
57	Disc Spring Ring	ASTM A276 410 ⁽³⁾

1. Cond. A Stainless Steel
2. Elgiloy Spring
3. Cond. T Stainless Steel
4. Grafoil Filled
5. Malleable Iron
6. Not Shown

Materials

13900 Type Pilot Valve

13900 Series Pilot Valve

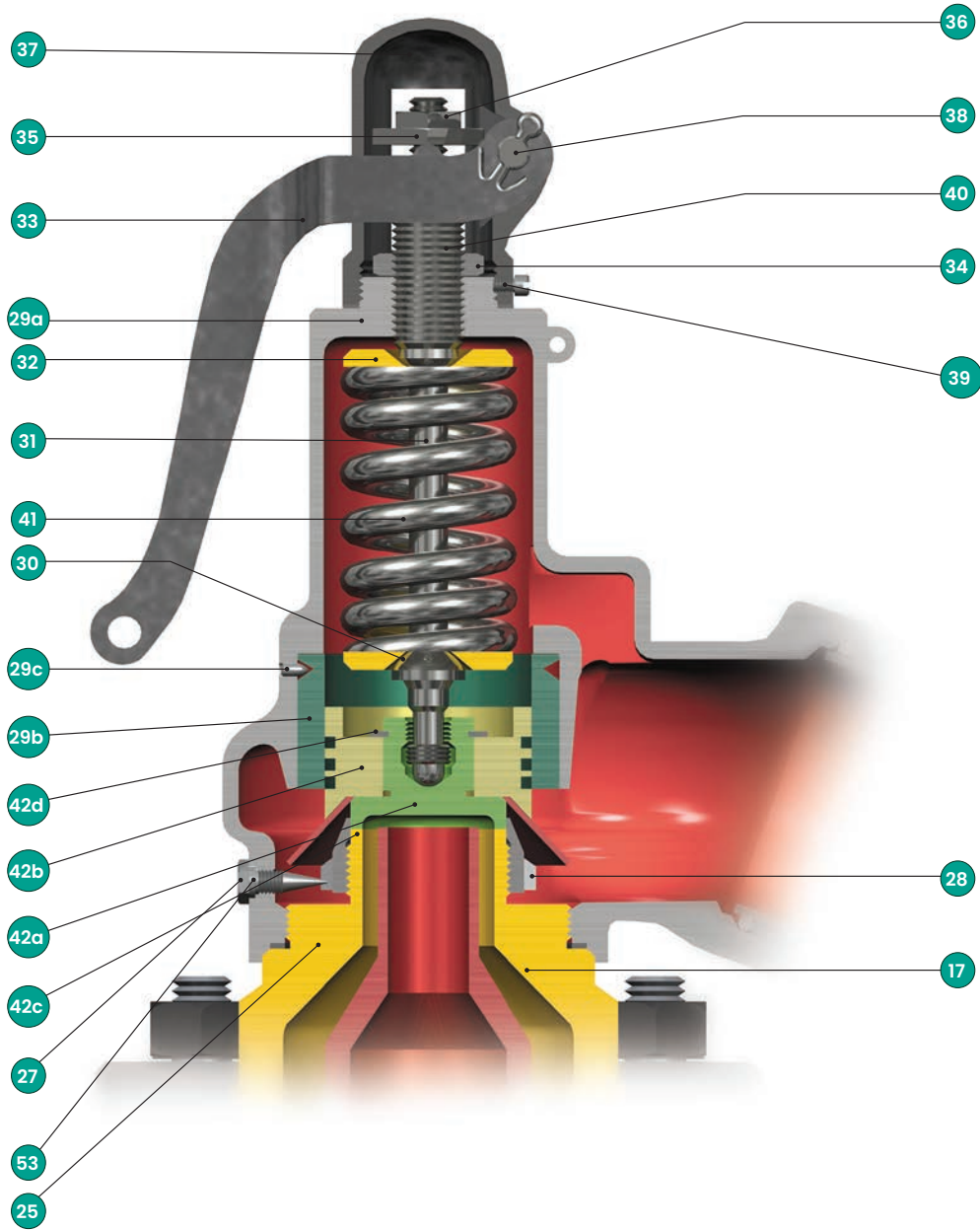

Options

Standard Options

Consolidated 13900 Series Pilot-Operated Safety Relief Valves are available with the following options:

Omit Pilot Discharge Piping:

Pilot valve vent to area other than main valve outlet.

Dump Valve Design:

Rather than having a spring-loaded safety valve as its pilot valve—which opens automatically at the pre-determined set pressure—the dump valve has a pilot that is operated by an electrical signal so that the valve may be opened at any time independently of the steam pressure.

Omit Pilot Discharge Piping



Dump Valve Design

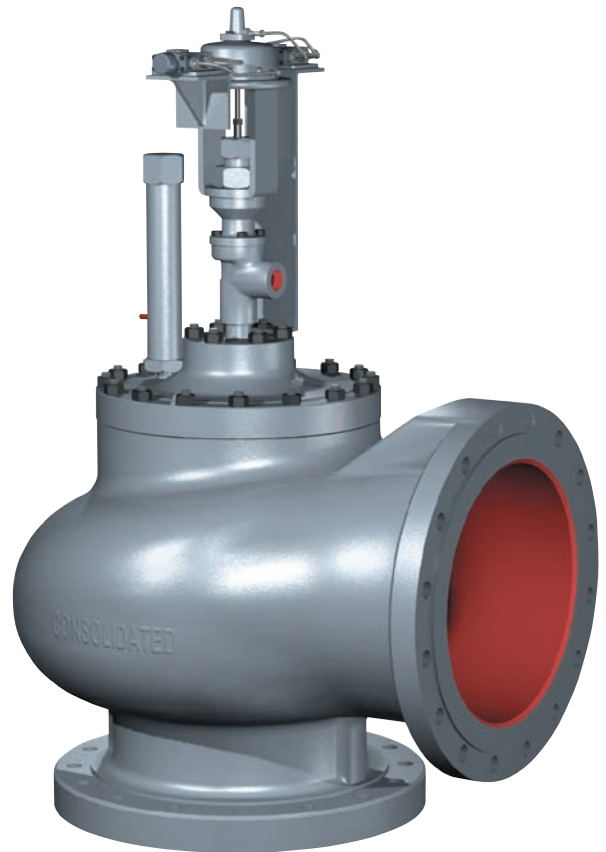

Dimensions and Weights

13900 Series Pilot-Operated Safety Relief Valve General Dimensions

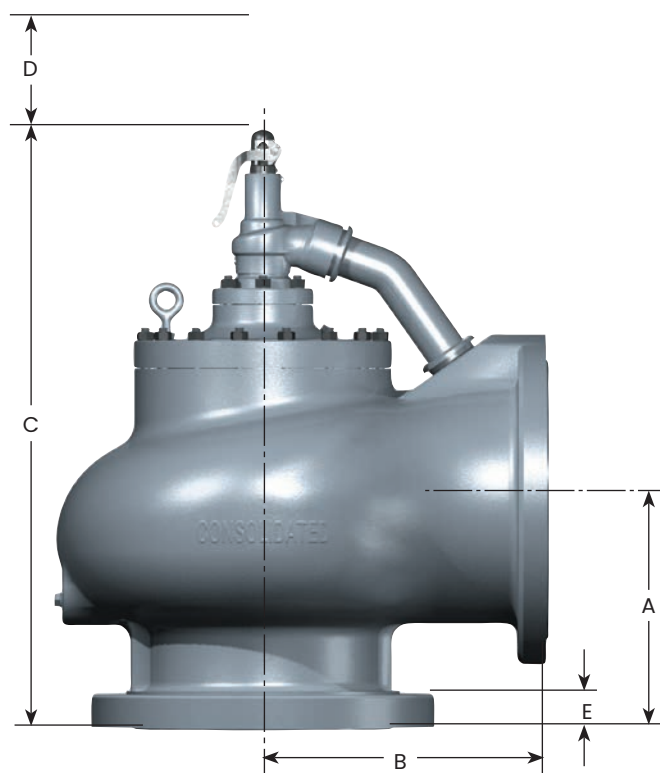

13900 Series Pilot-Operated Safety Relief Valve General Dimensions and Weights												
Valve Type	A		B		C		Dismantling Height D		E		Approx. Weight	
	in.	mm	in.	mm	in.	mm	in.	mm	in.	mm	lb.	kg
13906-114	17.00	431.8	21.00	533.4	48.00	1219.2	55.00	1397.0	2.50	63.5	1900	861.8
13906-143	18.00	457.2	22.00	558.8	49.50	1257.3	56.00	1422.4	2.38	60.3	2500	1134.0
13906-176	20.00	508.0	25.00	635.0	54.00	1371.6	60.50	1536.7	2.50	63.5	3650	1655.6
13906-200	20.00	508.0	25.00	635.0	54.00	1371.6	60.50	1536.7	2.50	63.5	3650	1655.6

Capacities

Valve Capacity for ASME B&PV Code Section XIII (UV) – Standard Bore, Steam									
Based at 10 percent overpressure or 3 psig (0.21 barg), whichever is greater, showing 90 percent of actual capacity.									
Orifice Designation		114		143		176		200	
Orifice Area		in ²	cm ²	in ²	cm ²	in ²	cm ²	in ²	cm ²
		114.000	735.480	143.100	923.224	176.700	1140.000	201.000	1296.770
Set Pressure		Orifice Capacity							
psig	barg	lb/hr	kg/hr	lb/hr	kg/hr	lb/hr	kg/hr	lb/hr	kg/hr
50	3.44	358876	162783	450483	204335	556257	252313	565655	256576
60	4.13	415513	188473	521578	236583	644046	292134	654926	297069
70	4.82	472151	214164	592673	268831	731834	331954	744198	337562
80	5.51	528788	239854	663768	301080	819622	371774	833469	378055
90	6.20	585426	265544	734863	333328	907410	411594	922740	418547
100	6.89	642063	291234	805958	365576	995198	451414	1012012	459040
120	8.27	755338	342615	948148	430072	1170775	531054	1190554	540026
140	9.65	868613	393996	1090338	494569	1346351	610694	1369097	621011
160	11.03	981888	445376	1232529	559065	1521927	690334	1547640	701997
180	12.41	1095164	496758	1374719	623562	1697504	769974	1726183	782983
200	13.78	1208439	548138	1516909	688058	1873080	849614	1904725	863968
220	15.16	1321714	599519	1659099	752554	2048656	929254	2083268	944954
240	16.54	1434989	650900	1801289	817051	2224233	1008895	2261811	1025940
260	17.92	1548264	702280	1943479	881547	2399809	1088535	2440353	1106925
280	19.30	1661539	753661	2085669	946043	2575386	1168175	2618896	1187911
300	20.68	1774814	805042	2227859	1010539	2750962	1247815	2797439	1268897

Valve Capacity for ASME B&PV Code Section XIII (UV) – Standard Bore, Air									
Based at 10 percent overpressure or 3 psig (0.21 barg), whichever is greater, showing 90 percent of actual capacity.									
Orifice Designation		114		143		176		200	
Orifice Area		in ²	cm ²	in ²	cm ²	in ²	cm ²	in ²	cm ²
		114.000	735.480	143.100	923.224	176.700	1140.000	201.000	1296.770
Set Pressure		Orifice Capacity							
psig	barg	ft ³ /min	m ³ /min	ft ³ /min	m ³ /min	ft ³ /min	m ³ /min	ft ³ /min	m ³ /min
50	3.44	127904	3621	160553	4546	198251	5613	201600	5708
60	4.13	148089	4193	185891	5263	229539	6499	233417	6609
70	4.82	168275	4765	211230	5981	260827	7385	265233	7510
80	5.51	188461	5336	236568	6698	292115	8271	297050	8411
90	6.20	208647	5908	261906	7416	323402	9157	328866	9312
100	6.89	228832	6479	287245	8133	354690	10043	360683	10213
120	8.27	269204	7623	337922	9568	417266	11815	424316	12015
140	9.65	309575	8766	388598	11003	479842	13587	487949	13817
160	11.03	349947	9909	439275	12438	542418	15359	551582	15619
180	12.41	390318	11052	489952	13873	604993	17131	615214	17420
200	13.78	430690	12195	540629	15308	667569	18903	678847	19222
220	15.16	471061	13338	591306	16743	730145	20675	742480	21024
240	16.54	511432	14482	641982	18178	792721	22447	806113	22826
260	17.92	551804	15625	692659	19613	855296	24219	869746	24628
280	19.30	592175	16768	743336	21048	917872	25991	933379	26430
300	20.68	632547	17911	794013	22483	980448	27763	997012	28232

Valve Configuration Code

13900 Series POSRV Valve Coding

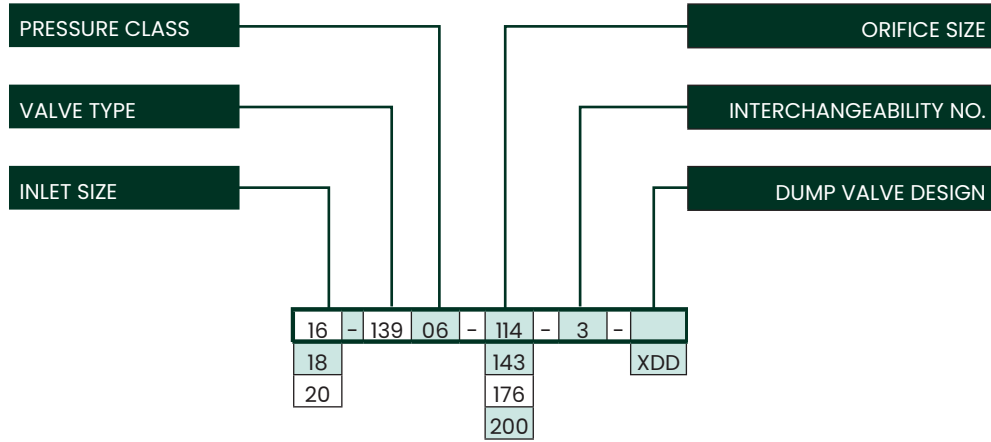

Standard Valve Construction				
Designation	Inlet Size		Orifice Size	
	in.	mm	in ² .	cm ²
114	16.0	406.40	114.000	735.482
143	18.0	457.20	143.100	923.224
176	20.0	508.00	176.700	1139.998
200	20.0	508.00	201.000	1296.772

Pressure Class	
Designation	Class
06	300#

Ordering a 13900 Series POSRV

13900 Series POSRV Specification Sheet

Page ____ of ____

Requisition No. _____

Job No. _____

Date _____

Revised By _____

General

1. Number of Valves:

2. Size of Valve Inlet:

3. Type Number of Valve:

4. Consolidated Manufacturer:

5. Body Material:

6. Trim material (if any other than standard is required):

7. O-ring Seat Material:

8. Set Pressure:

9. Opening temperature and Relieving Temperature:

10. Back Pressure, if any (indicate if Constant or Variable):

11. Required Capacity:

12. Lading Fluid:

13. Allowable Overpressure:

14. Density:

a. Vapor - Molecular Weight:

b. Gases - Specific Gravity (Air = 1):

Other

15. Code Marking Required

a. ASME Unified Pressure Vessel Code:

Notes

Notes:

Lined writing area with horizontal lines.

Notes:

Direct Sales Office Locations

Australia

Brisbane
Phone: +61-7-3001-4319

Perth
Phone: +61-8-6595-7018

Melbourne
Phone: +61-3-8807-6002

Brazil

Phone: +55-19-2104-6900

China

Phone: +86-10-8400-7888

France

Courbevoie
Phone: +33-1-4904-9000

India

Mumbai
Phone: +91-22-8354790

New Delhi

Phone: +91-11-2-6164175

Italy

Phone: +39-081-7892-111

Japan

Tokyo
Phone: +81-03-6871-9008

Korea

Phone: +82-31-620-1736

Malaysia

Phone: +60-3-2161-03228

Mexico

Phone: +52-55-3640-5060

Russia

Veliky Novgorod
Phone: +7-8162-55-7898

Moscow

Phone: +7-495-585-1276

Saudi Arabia

Phone: +966-3-341-0278

Singapore

Phone: +65-6861-6100

South Africa

Phone: +27-83-387-9300

South & Central America and the Caribbean

Phone: +55-12-2134-1201

Spain

Phone: +34-935-877-605

United Arab Emirates

Phone: +971-4-8991-777

United Kingdom

Phone: +44-7919-382-156

United States

Houston, Texas

Phone: +1-713-966-3600

Find the nearest local Channel Partner in your area:
valves.bakerhughes.com/contact-us

Tech Field Support & Warranty:

Phone: +1-866-827-5378
valvesupport@bakerhughes.com

valves.bakerhughes.com

Copyright 2022 Baker Hughes Company. All rights reserved. Baker Hughes provides this information on an "as is" basis for general information purposes. Baker Hughes does not make any representation as to the accuracy or completeness of the information and makes no warranties of any kind, specific, implied or oral, to the fullest extent permissible by law, including those of merchantability and fitness for a particular purpose or use. Baker Hughes hereby disclaims any and all liability for any direct, indirect, consequential or special damages, claims for lost profits, or third party claims arising from the use of the information, whether a claim is asserted in contract, tort, or otherwise. Baker Hughes reserves the right to make changes in specifications and features shown herein, or discontinue the product described at any time without notice or obligation. Contact your Baker Hughes representative for the most current information. The Baker Hughes logo, and Consolidated, are trademarks of Baker Hughes Company. Other company names and product names used in this document are the registered trademarks or trademarks of their respective owners.