

# Masoneilan™

## 173 Series

Self Operating Pressure Regulators

Instruction Manual (Rev.B)



**Baker Hughes** 

**THESE INSTRUCTIONS PROVIDE THE CUSTOMER/OPERATOR WITH IMPORTANT PROJECT-SPECIFIC REFERENCE INFORMATION IN ADDITION TO THE CUSTOMER/OPERATOR'S NORMAL OPERATION AND MAINTENANCE PROCEDURES. SINCE OPERATION AND MAINTENANCE PHILOSOPHIES VARY, BAKER HUGHES COMPANY (AND ITS SUBSIDIARIES AND AFFILIATES) DOES NOT ATTEMPT TO DICTATE SPECIFIC PROCEDURES, BUT TO PROVIDE BASIC LIMITATIONS AND REQUIREMENTS CREATED BY THE TYPE OF EQUIPMENT PROVIDED.**

**THESE INSTRUCTIONS ASSUME THAT OPERATORS ALREADY HAVE A GENERAL UNDERSTANDING OF THE REQUIREMENTS FOR SAFE OPERATION OF MECHANICAL AND ELECTRICAL EQUIPMENT IN POTENTIALLY HAZARDOUS ENVIRONMENTS. THEREFORE, THESE INSTRUCTIONS SHOULD BE INTERPRETED AND APPLIED IN CONJUNCTION WITH THE SAFETY RULES AND REGULATIONS APPLICABLE AT THE SITE AND THE PARTICULAR REQUIREMENTS FOR OPERATION OF OTHER EQUIPMENT AT THE SITE.**

**THESE INSTRUCTIONS DO NOT PURPORT TO COVER ALL DETAILS OR VARIATIONS IN EQUIPMENT NOR TO PROVIDE FOR EVERY POSSIBLE CONTINGENCY TO BE MET IN CONNECTION WITH INSTALLATION, OPERATION OR MAINTENANCE. SHOULD FURTHER INFORMATION BE DESIRED OR SHOULD PARTICULAR PROBLEMS ARISE WHICH ARE NOT COVERED SUFFICIENTLY FOR THE CUSTOMER/OPERATOR'S PURPOSES THE MATTER SHOULD BE REFERRED TO BAKER HUGHES.**

**THE RIGHTS, OBLIGATIONS AND LIABILITIES OF BAKER HUGHES AND THE CUSTOMER/OPERATOR ARE STRICTLY LIMITED TO THOSE EXPRESSLY PROVIDED IN THE CONTRACT RELATING TO THE SUPPLY OF THE EQUIPMENT. NO ADDITIONAL REPRESENTATIONS OR WARRANTIES BY BAKER HUGHES REGARDING THE EQUIPMENT OR ITS USE ARE GIVEN OR IMPLIED BY THE ISSUE OF THESE INSTRUCTIONS.**

**THESE INSTRUCTIONS ARE FURNISHED TO THE CUSTOMER/OPERATOR SOLELY TO ASSIST IN THE INSTALLATION, TESTING, OPERATION, AND/OR MAINTENANCE OF THE EQUIPMENT DESCRIBED. THIS DOCUMENT SHALL NOT BE REPRODUCED IN WHOLE OR IN PART WITHOUT THE WRITTEN APPROVAL OF BAKER HUGHES.**

# Table Of Contents

Safety Information .....	1
About this Manual .....	1
Warranty .....	1
<b>1. General Information .....</b>	<b>2</b>
<b>2. Transport, Storage and Handling .....</b>	<b>2</b>
<b>3. Installation and Assembly Instructions 173 Series Pressure Regulator</b>	
3.1 Cross-Section Drawing .....	3
3.2 Installation .....	4
3.3 Start-Up and Calibration.....	4
3.4 Maintenance.....	5
<b>4. Installation and Assembly Instructions – 173-50 Differential Pressure Regulator</b>	
4.1 Cross-Section Drawing – 173-50 Single Diaphragm.....	6
4.2 Cross-Section Drawing – 173-50 Double Diaphragm .....	7
4.3 Installation .....	8
4.4 Start-Up and Calibration.....	8
4.5 Maintenance.....	8

## Safety Information

### Important - Please read before installation

These instructions contain **DANGER**, **WARNING**, and **CAUTION** labels, where necessary, to alert you to safety related or other important information. Read the instructions carefully before installing and maintaining your control valve. **DANGER** and **WARNING** hazards are related to personal injury. **CAUTION** hazards involve equipment or property damage. Operation of damaged equipment can, under certain operational conditions, result in degraded process system performance that can lead to injury or death. Total compliance with all **DANGER**, **WARNING**, and **CAUTION** notices is required for safe operation.



This is the safety alert symbol. It alerts you to potential personal injury hazards. Obey all safety messages that follow this symbol to avoid possible injury or death.



Indicates a potentially hazardous situation which, if not avoided, could result in death or serious injury.



Indicates a potentially hazardous situation which, if not avoided, could result in serious injury.



Indicates a potentially hazardous situation which, if not avoided, could result in minor or moderate injury.



When used without the safety alert symbol, indicates a potentially hazardous situation which, if not avoided, could result in property damage.

**Note: Indicates important facts and conditions.**

## About this Manual

- The information in this manual is subject to change without prior notice.
- The information contained in this manual, in whole or part, shall not be transcribed or copied without Baker Hughes's written permission.
- Please report any errors or questions about the information in this manual to your local supplier.
- These instructions are written specifically for the 173 Series back pressure regulators, and do not apply for other valves outside of this product line.

## Useful Period

The current estimated useful life period for the 173 Series back pressure regulators is 25+ years. To maximize the useful life of the product, it is essential to conduct annual inspections, routine maintenance and ensure proper installation to avoid any unintended stresses on the product. The specific operating conditions will also impact the useful life of the product. Consult the factory for guidance on specific applications if required prior to installation.

## Warranty

Items sold by Baker Hughes are warranted to be free from defects in materials and workmanship for a period of one year from the date of shipment provided said items are used according to Baker Hughes recommended usages. Baker Hughes reserves the right to discontinue manufacture of any product or change product materials, design or specifications without notice.

### **Note: Prior to installation:**

- The regulator must be installed, put into service and maintained by qualified and competent professionals who have undergone suitable training.
- All surrounding pipe lines must be thoroughly flushed to ensure all entrained debris has been removed from the system.
- Under certain operating conditions, the use of damaged equipment could cause a degradation of the performance of the system which may lead to personal injury or death.
- Changes to specifications, structure, and components used may not lead to the revision of this manual unless such changes affect the function and performance of the product

# 1. General Information

The following instructions are designed to assist maintenance personnel in performing most of the maintenance required on the 173 Series regulators, and if followed carefully, will reduce maintenance time.

Baker Hughes has highly skilled Service Engineers available for start-up, maintenance and repair of our regulators and component parts. In addition, regularly scheduled training programs are conducted to train customer service and instrumentation personnel in the operation, maintenance and application of our control valves, regulators and instrumentation. Arrangements for these services can be made through your Baker Hughes Representative or District Office. When performing maintenance, use only genuine Baker Hughes replacement parts. Parts are obtainable through your local Baker Hughes Representative or District Office. When ordering parts always include the MODEL and SERIAL NUMBER of the unit being repaired.

# 2. Transport, Storage and Handling

## Transport

Depending on their size, regulators can be transported loose or packed, in cardboard boxes or in wooden crates.

All the regulator ends are fitted with covers to prevent dirt from entering. Units can be placed on pallets if required. Follow all instructions noted on the packaging.

**⚠ CAUTION**

**Operators moving loads must take all necessary precautions to prevent accidents.**

## Storage

Regulators must be kept in a dry place to protect them from atmospheric conditions. They may only be removed from their crates or packing immediately prior to installation.

The end protections and covers must be kept on until installation. Regulators, whether packed or not, must not be subject to impact.

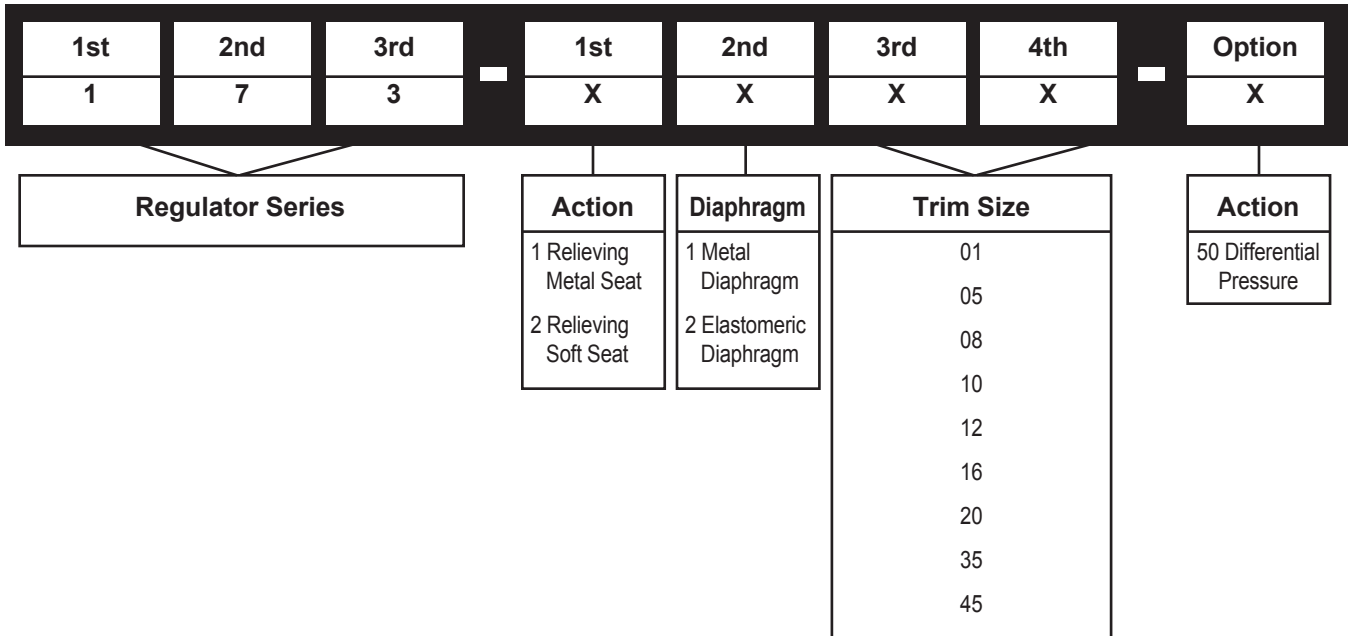
Regulators, whether packed or not, must always be kept upright, that is, never lying on one side, in order to prevent distortion and damage to internal parts.

## Handling

When unpacking the regulators and removing the end protectors immediately prior to installation, take great care to make sure that foreign material does not enter the regulator inlet and outlet ports while it is being connected.

**⚠ CAUTION**

**When handling the regulator, make sure the work area is kept clear in order to prevent injury to people and damage to property.**

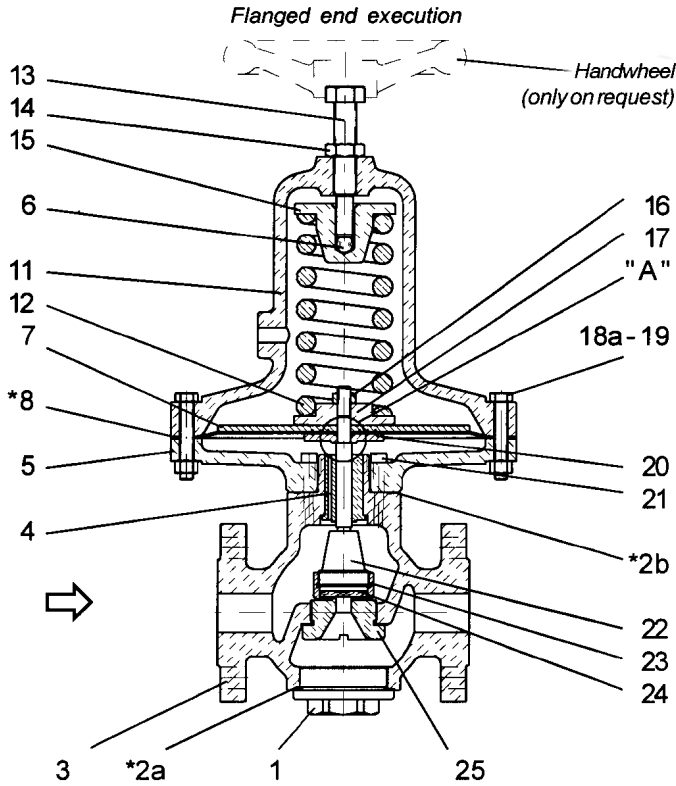


# 3. Installation and Assembly Instructions – 173 Series Pressure Regulator

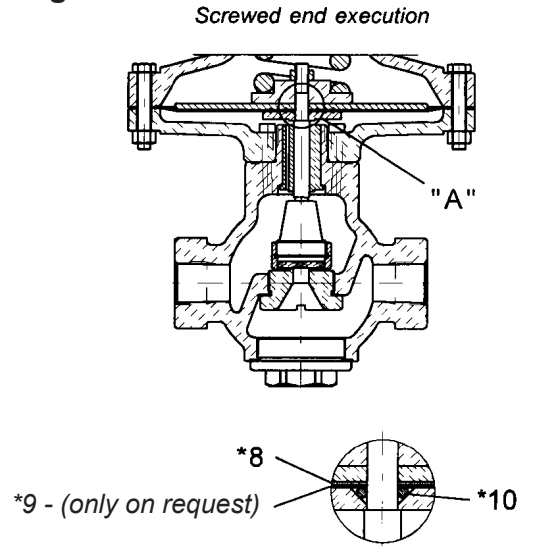
## 3.1 Cross-section Drawing

Figures 1 through 5 below show the cross-sectional view of the 173 Series regulators along with part names and versions.

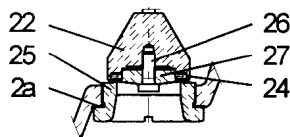
**Figure 1**



**Figure 2**

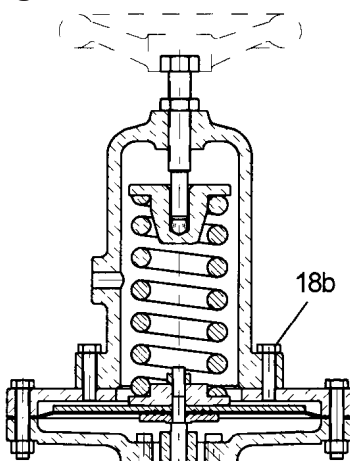


**Figure 5**

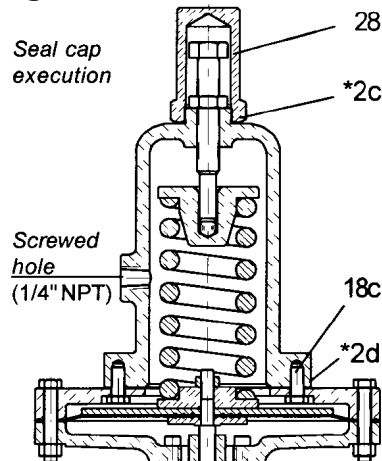


Resilient tightness disc for valves ND 40 (1.1/2") and ND 50

**Figure 3**



**Figure 4**



ATEX Construction Gr. II Cat. 2

Ref.	Part Name
1	Blindhead
*2	Gasket Set
3	Body
4	Guide
5	Diaphragm Case
6	Ball
7	Diaphragm Plate (Upper)
*8	Diaphragm
*9	Protector - optional
*10	O-Ring
11	Spring Case
12	Spring
13	Adjusting Screw
14	Lock Nut
15	Spring Button
16	Nut
17	Spring Guide
18	Screw
19	Nut
20	Diaphragm Plate - Lower
21	Screw
*22	Plug
*23	Ring
*24	Disc
*25	Seat
*26	Screw
*27	Gasket Plate
28	Cap

\*Recommended spare parts.

## 3.2 Installation

**3.2.1** 173 Series regulators must be installed with the actuator (2) facing upwards and the diaphragm perfectly horizontal, as shown in Fig.6.

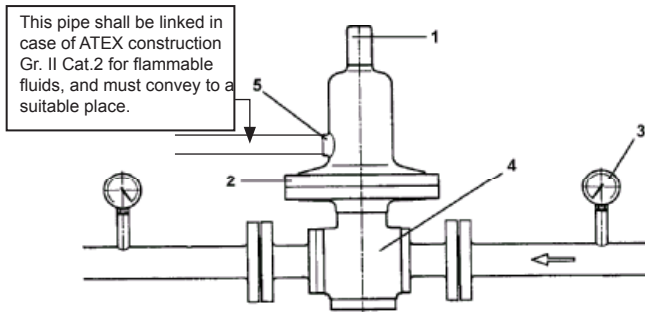
In pressure reducing applications regulating very low downstream pressures (normally lower than 100 mm water column), the regulator must be installed with the actuator facing downwards and perfectly horizontal (below pipeline) as indicated by the nameplate orientation as shown in Fig. 7.

**3.2.2** Before installation, ensure that the piping is clean and free of any debris (machining chips, weld slag, etc). Contaminants remaining in the piping system can damage internal components of the regulator.

**! WARNING**

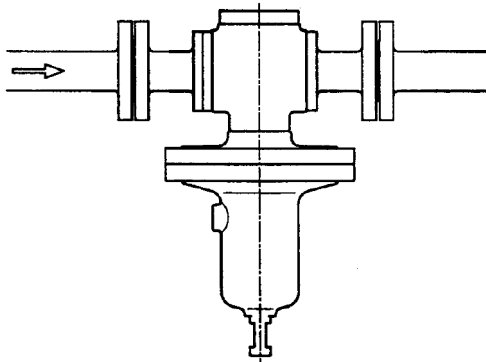
**When welding piping, do not attach the earth connector to the regulator as this may damage important sliding parts.**

**Figure 6**



- 1) Adjustment screw (spring holder)
- 2) Actuator
- 3) Pressure gauge
- 4) Regulator body
- 5) Drain hole

**Figure 7**

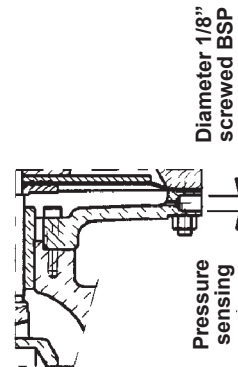


**3.2.3 WARNING/CAUTION ON ATEX USAGE:** When handling or working with harmless fluids (for instance, inert gases, like nitrogen, carbon dioxide and noble gases) the spring cover is not normally airtight (ATEX construction, Group II- Cat.2), and has a hole (5) (as shown in Figures 6 and 7) that prevents it from pressurizing if the diaphragm breaks. If the spring cover is airtight, and made from carbon and stainless steel (as shown in Figure 4), the hole (5) (as shown in Figures 6 and 7) is always threaded 1/4"NPT and must be connected to the pipe conveying the discharge to a suitable place (safely and constantly at atmospheric pressure).

**3.2.4** Bear in mind that the regulated pressure sensing port is located inside the regulator, therefore the pressure drops in the inter-connecting piping between the regulator and the point of use will affect the accuracy of the maintained set pressure. This pressure drop must be considered when calculating the size of the connection piping.

**3.2.5** When it is essential to avoid pressure variations at the point of use, the regulators are fitted with an external sensing line connection, as shown in Fig 8. The 1/8" female threaded port must be connected to a nipple as near as possible to the point of use.

**Figure 8**



External sensing line (only on request)

## 3.3 Start-Up and Calibration

**3.3.1** The 173 Series pressure regulators are shipped with a pressure setting at the low end of the adjustable range unless otherwise specified by the customer. The pressure setting can be changed to any value within the adjustable range by loosening the adjusting screw locknut (14) and turning the adjusting screw (13) clockwise to increase the pressure setting or counterclockwise to decrease the pressure setting.

**! WARNING**

**During regulator start-up or operation, do not touch any part of the regulator as this can conduct heat if the fluid used is at a high temperature.**

## 3.4 Maintenance

**3.4.1** The required maintenance interval varies depending on application. The user must establish a suitable interval based on the operating conditions. Prior to disassembly, remove all system pressure from the regulator.

Before starting the above operation, make sure the recommended spare parts are available (refer to the parts list indicated in Figures 1 through 5).

### 3.4.2 Disassembly

Refer to Figures 1 through 5 while completing the following disassembly procedures.

#### 3.4.2.1 Actuator Disassembly

Remove spring compression by turning the adjustment screw (13) counterclockwise after loosening the locknut (14). The position of the locknut should be noted to allow closer preliminary adjustment when reassembling. If the regulator is equipped with a sealed cap (as shown in Figure 4), first remove the cap (28) and gasket.

Remove the spring case (11) by loosening the nuts (19).

**Note: It is not necessary to remove the housings on actuator sizes 220 and 360.**

Remove the spring. Unscrew the nut (16).

Remove the diaphragm and washers.

#### 3.4.2.2 Body Disassembly

Unscrew and remove the blindhead (1) with gasket. Unscrew the seat (25) with a screwdriver (refer to Figures 1, 2, and 5).

Pull the plug off its guide and remove it from the body.

#### 3.4.2.3 Parts Inspection

All the components are now ready to be inspected. Replace any worn items. Clean all parts.

Pay particular attention to the condition of the disk and plug, both elastomeric and metal, and the seat.

If the seat is worn, it may be able to be restored by lapping using a metal disk and abrasive paste.

The diaphragm should be replaced if it shows any damage. The same applies to the Teflon diaphragm protector (if included).

Gaskets should not be reused.

If preferred, the regulator may be returned to one of Baker Hughes's authorized Masoneilan repair centers (MARC) repair center to be reconditioned.

#### 3.4.2.4 Reassembly

Carry out the disassembly operations in reverse order.

Push the stem of the plug into body and push it into its guide. Tighten the seat (25), making sure the washer is new and correctly positioned. Replace the small retention ring (10) after thoroughly cleaning its seat.

Install the diaphragm, taking care to install the protector (9), if applicable, underneath, towards the regulator body on top the lower diaphragm plate (20). Install the upper diaphragm plate (7) and the spring guide (17) and fully tighten the nut (16).

Align the holes of the diaphragm with those in the actuator flange and install the spring, spring holder and spring case. Install the blindhead (1). Return the adjusting screw (13) to the position marked by the nut (14) or the position noted (see 3.4.2.1). Exact adjustment must be checked when the regulator is returned to service.

#### 3.4.2.5 Diaphragm Replacement

The diaphragm may require replacement without having to make other repairs. If the regulator is easy to access and isolate, it can be replaced while leaving the regulator installed in the piping. In this case, isolate the regulator and vent all pressure. To prevent accidental pressurization while working on the regulator, make sure that the isolation valves are locked. Remove the actuator following the instructions in section 3.4.1.2.

Replace and install the diaphragm and reassemble the actuator as shown in section 3.4.2.4. Check calibration once more when the regulator is returned to service.

## WARNING

**When welding piping, do not attach the earth connector to the regulator as this may damage important sliding parts.**



# 4. Installation and Assembly Instructions

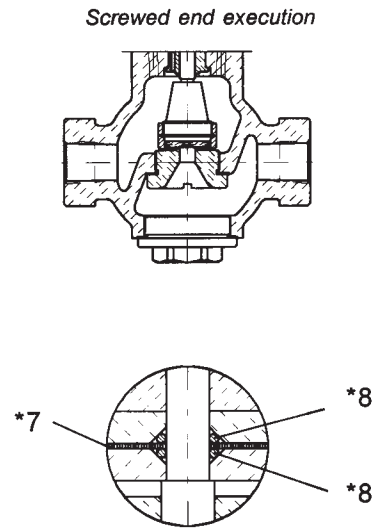
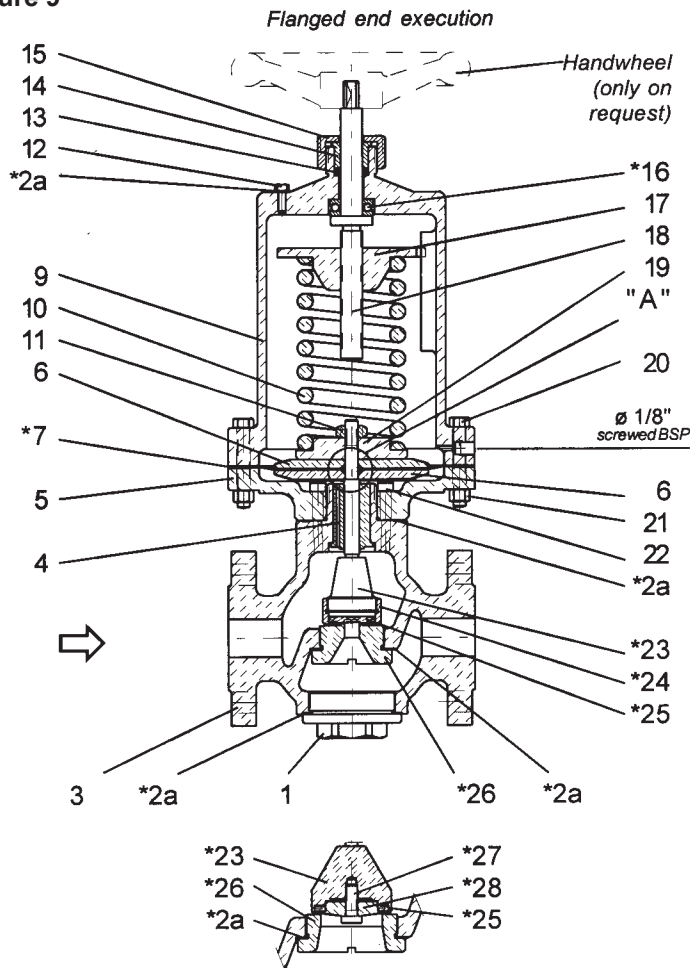
## – 173-50 Differential Pressure Regulator

There are two distinct types of 173-50 Series differential pressure regulators – those with a single diaphragm and those with a double diaphragm.

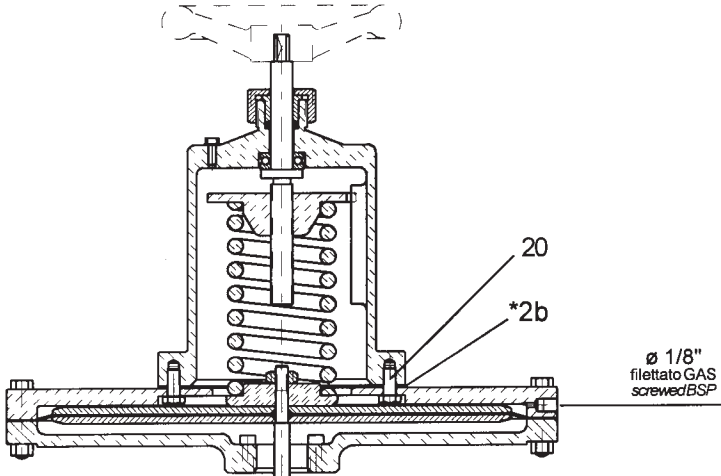
### 4.1 Cross-Section Drawing 173-50 Single Diaphragm

In regulators with a single diaphragm (as shown in Figure 9), one of the controlled pressures acts under the diaphragm through an internal sensing line connection on the spring housing. The plug is kept closed by the spring.

Figure 9



Resilient tightness disc for valves ND 40 (1.½") and ND 50 (2")



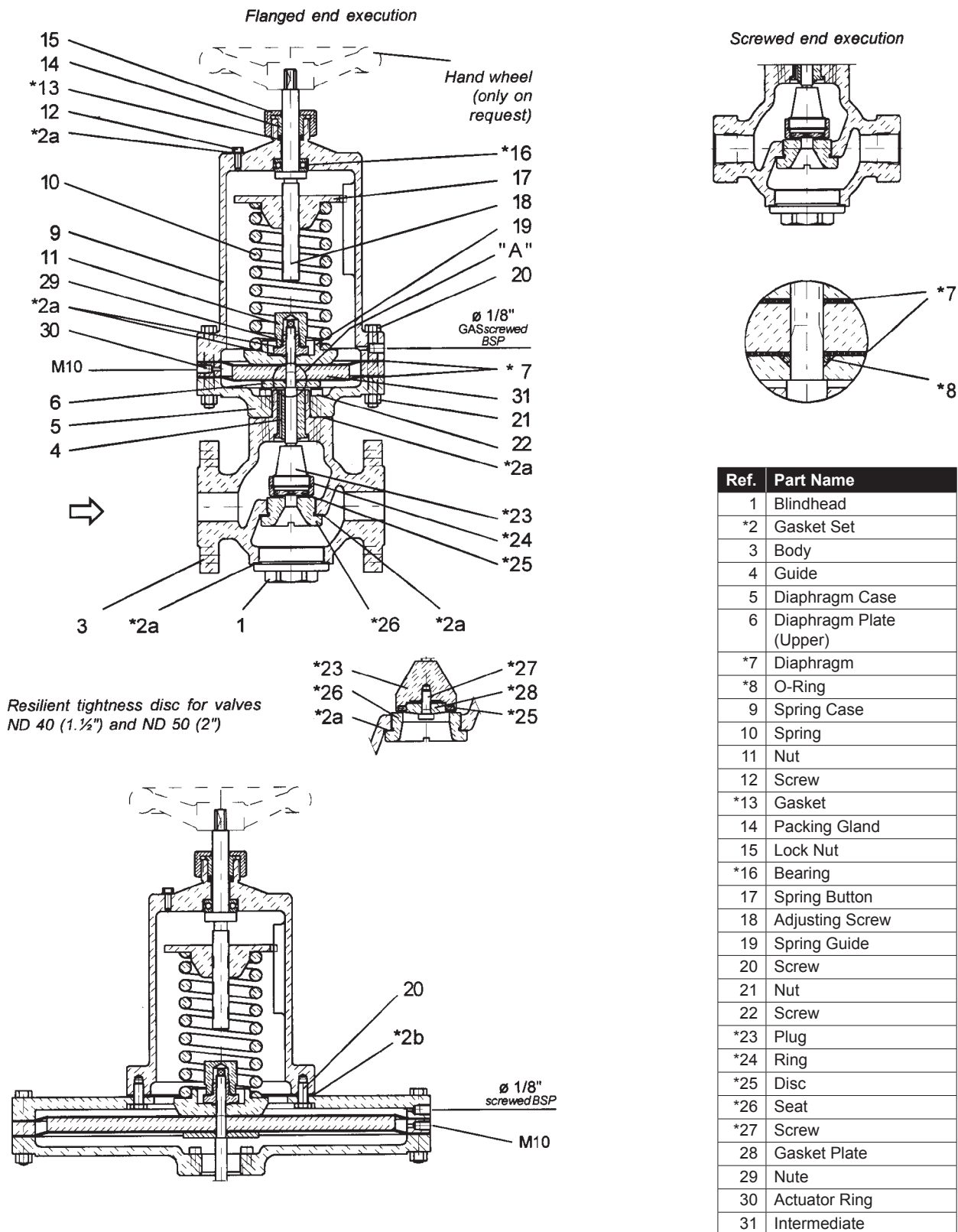
Ref.	Part Name
1	Blindhead
*2	Gasket Set
3	Body
4	Guide
5	Diaphragm Case
6	Diaphragm Plate (Upper)
*7	Diaphragm
*8	O-Ring
9	Spring Case
10	Spring
11	Nut
12	Screw
*13	Gasket
14	Lock Nut
15	Packing Gland
*16	Bearing
17	Spring Button
18	Adjusting Screw
19	Spring Guide
20	Screw
21	Nut
22	Screw
*23	Plug
*24	Ring
*25	Disc
*26	Seat
*27	Screw
28	Gasket Plate

\*Recommended spare parts.

## 4.2 Cross-Section Drawing 173-50 Double Diaphragm

These regulators shown in Figure 10 have two diaphragms separated by a chamber that communicates with the outside. The controlled pressures act under the lower diaphragm (through an internal sensing line connection) and over the upper diaphragm (through a sensing line nipple on the spring housing). The plug is kept closed by the spring.

Figure 10



\*Recommended spare parts.

## 4.3 Installation

### 4.3.1 Positioning

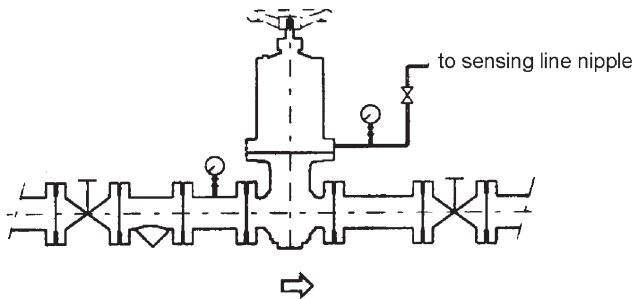
All 173-50 regulators must be installed with the actuator facing upwards and the diaphragm horizontal.

### 4.3.2 Installation Diagrams

In most cases the flow crosses the regulator as shown by the arrow in Figures 9 and 10.

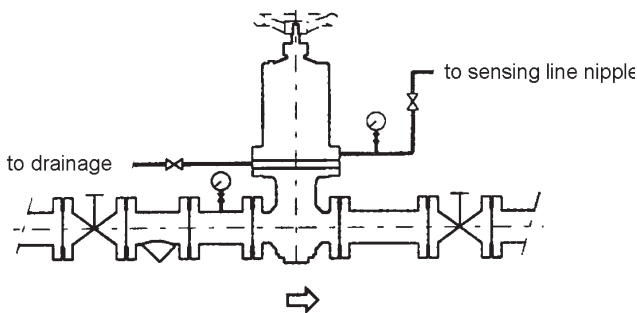
The installation diagrams are therefore as follows:

Figure 11



Example of installation layout for 173-50 single diaphragm regulators

Figure 12



Example of installation layout for 173-50 double diaphragm regulators

### 4.3.3 Isolation Valves and Filter/Pressure Gauges

Install an isolation valve upstream, downstream and on the sensing and discharge line connection piping, in order to service the regulator (if necessary) while the plant is pressurized.

Install one filter or pressure gauge upstream from the regulator and another one on the sensing line connection (as shown in Figures 11 and 12) in order to calibrate the differential pressure and keep it constantly under control.

### 4.3.4 Contamination

Prior to installing the regulator in the piping, make sure the inside of the pipes are clean and free of any debris (machining cuttings, weld slag, etc.), especially the upstream section; blow down the piping if possible to eliminate any remaining dirt: small drops of weld slag may seriously damage the regulator.

### 4.3.5 Double Diaphragm Discharge Venting

In double diaphragm regulators, the chamber between the two diaphragms must be connected to piping to vent the discharge to a suitable place, safely and constantly at atmospheric pressure. This hole can be closed with a plug or pressure gauge with an electrical contact for the remote signaling that the diaphragm has broken, as long as the downstream plant is protected (as shown in Figure 12).

### 4.3.6 Safety Relief

If there is any chance that an overflow regulator failure could cause the pressure upstream from the reduction regulator to exceed the maximum admissible pressure for the installation, a safety relief valve must be installed upstream – without an isolation valve in between – in order to discharge the entire flow crossing the differential pressure regulator.

### 4.3.7 Pressure Drops

Because the regulated pressure sensing port is located inside the regulator, the pressure drops in the inter-connecting piping between the regulator and the point of use will affect the accuracy of the maintained set pressure. This pressure drop must be considered when calculating the size of the connection.

### 4.3.8 Pressure Variation

When it is essential to avoid pressure variations at the point of use, the regulators are fitted with an external sensing line connection that replaces the internal connection and is fitted to the lower flange of the actuator. This connection must be connected as near as possible to the point of use where the installation of a pressure gauge is also recommended.

## 4.4 Startup and Calibration

(Refer to Figures 9 and 10)

### 4.4.1 Pressure Difference

This operation is similar for both single diaphragm and double diaphragm regulators. The sensing line connection regulator and the upstream and downstream isolation valves must be closed. Slightly open the downstream valve and then the upstream valve together with the sensing line connection, making sure that the pressure difference read on the pressure gauges is correct. If necessary, to reduce the pressure difference, turn the adjustment screw (18) clockwise to increase differential pressure and counterclockwise to decrease.

### 4.1.2 Calibration

When the required value is reached, fully open all the valves. When the downstream system is working at full power, calibrate by adjusting the screw (18).

## 4.5 Maintenance

(Refer to Figures 9 and 10)

### 4.5.1 Maintenance Interval

The required maintenance interval will vary depending on application. The user must establish a suitable maintenance schedule depending on the operating conditions. Prior to disassembly, remove all system pressure from the regulator.

Before starting the above operation, make sure the recommended spare parts are available (See the parts listed in Figures 9 and 10).

### 4.5.2 Disassembly

Disassembling and reassembling operations for all types of 173-50 regulators as long as the diaphragms are considered. These are:

- 1 single elastomeric diaphragm for 173-50 single diaphragm regulators;
- 2 elastomeric diaphragms (one per side) for 173-50 double diaphragm regulators.

Make sure the spares match the above and take great care when mounting the diaphragm assembly.

#### 4.5.2.1 Actuator Disassembly

Release the spring compression by turning the adjustment screw counterclockwise, counting and noting the number of turns in order to restore calibration after reassembly. Remove the spring housing (9) by loosening the nuts (21). It is not necessary to remove the housings of the 220 and 360 actuators. Remove the spring.

- For single diaphragm regulators: unscrew the nut (11) and remove the diaphragm with the diaphragm plate (6) and spring guide (19). (See Figure 9)
- For double diaphragm regulators: unscrew the lock nut (11) and nut (29) and remove the double diaphragm assembly with ring (30), intermediate plate (31), diaphragm plate (6) and spring guide (19). (See Figure 10)

#### 4.5.2.2 Body Disassembly

Unscrew and remove the cover with relevant gasket. Unscrew the seat with a screwdriver. (See Figures 9 and 10)

Pull the plug off its guide and remove it from the body.

#### 4.5.3 Parts Inspection

(Refer to Figures 9 and 10)

All of the components are now ready to be inspected. Replace any worn items. Clean all parts.

Pay particular attention to the condition of the disc of the plug (24), both elastomeric and metal, and the seat.

If the seat is worn, it may be able to be restored by lapping using a metal disc and abrasive paste.

The diaphragm should be replaced if it shows any damage. The same applies to the Teflon diaphragm protector (if included).

Gaskets should not be reused.

If preferred, the regulator may be returned to an authorized Baker Hughes repair center to be reconditioned.

#### 4.5.4 Reassembly

Carry out the disassembly operations in reverse order. Push the stem of the plug into its guide and tighten the seat (26). Screw the cover (1) back on. Install the diaphragm/s (see section 4.5) taking care to properly arrange the Teflon protectors. Make sure the seats of the O-rings are perfectly clean before mounting them. Assemble:

- For single diaphragm regulators: plug assembly, diaphragm plate, diaphragm and spring guide (with gaskets), and nut.
- For double diaphragm regulators: plug assembly, diaphragm plate, lower diaphragm, intermediate plate and actuator ring, upper diaphragm, spring guide (with gaskets), nut and lock nut.

Match the holes of the diaphragm/s with the holes in the actuator flange and install the spring, spring holder and housing. Turn the adjustment screw the number of turns noted during dismounting. Exact calibration must then be checked when the regulator is placed back into service.

#### 4.5.5 Replacing the Diaphragm

The diaphragm may require replacement without having to make other repairs. If the regulator is easy to access and isolate, it can be replaced while leaving the regulator installed in the piping. In this case, isolate the regulator and vent all pressure. To prevent accidental pressurization while working on the regulator, make sure that the isolation valves are locked. Remove the actuator following the instructions in section 4.5.2.

Replace and install the diaphragm and reassemble the actuator as shown in section 4.5, 4.5.3 and 4.5.6. Check calibration once more when the regulator is returned to service.

## Note

## Note

## Note

# Direct Sales Office Locations

**Australia**

Brisbane  
Phone: +61-7-3001-4319

Perth  
Phone: +61-8-6595-7018

Melbourne  
Phone: +61-3-8807-6002

**Brazil**

Phone: +55-19-2104-6900

**China**

Phone: +86-10-5738-8888

**France**

Courbevoie  
Phone: +33-1-4904-9000

**India**

Mumbai  
Phone: +91-22-8354790

New Delhi

Phone: +91-11-2-6164175

**Italy**

Phone: +39-081-7892-111

**Japan**

Tokyo  
Phone: +81-03-6871-9008

**Korea**

Phone: +82-2-2274-0748

**Malaysia**

Phone: +60-3-2161-03228

**Mexico**

Phone: +52-55-3640-5060

**Russia**

Veliky Novgorod  
Phone: +7-8162-55-7898

Moscow

Phone: +7-495-585-1276

**Saudi Arabia**

Phone: +966-3-341-0278

**Singapore**

Phone: +65-6861-6100

**South Africa**

Phone: +27-11-452-1550

**South & Central  
America and the Caribbean**

Phone: +55-12-2134-1201

**Spain**

Phone: +34-935-877-605

**United Arab Emirates**

Phone: +971-4-8991-777

**United Kingdom**

Phone: +44-7919-382-156

**United States**

Houston, Texas  
Phone: +1-713-966-3600

**Find the nearest local Channel Partner in your area:**

[valves.bakerhughes.com/contact-us](http://valves.bakerhughes.com/contact-us)

## Tech Field Support & Warranty:

Phone: +1-866-827-5378

[valvesupport@bakerhughes.com](mailto:valvesupport@bakerhughes.com)

[valves.bakerhughes.com](http://valves.bakerhughes.com)

Copyright 2020 Baker Hughes Company. All rights reserved. Baker Hughes provides this information on an "as is" basis for general information purposes. Baker Hughes does not make any representation as to the accuracy or completeness of the information and makes no warranties of any kind, specific, implied or oral, to the fullest extent permissible by law, including those of merchantability and fitness for a particular purpose or use. Baker Hughes hereby disclaims any and all liability for any direct, indirect, consequential or special damages, claims for lost profits, or third party claims arising from the use of the information, whether a claim is asserted in contract, tort, or otherwise. Baker Hughes reserves the right to make changes in specifications and features shown herein, or discontinue the product described at any time without notice or obligation. Contact your Baker Hughes representative for the most current information. The Baker Hughes logo and Masoneilan are trademarks of Baker Hughes Company. Other company names and product names used in this document are the registered trademarks or trademarks of their respective owners.

**Baker Hughes** 