

SEIFERT

ERESCO 200 MF4-R

Portable air-cooled 200 kV X-ray machine for radioscopic applications with high magnification

The ERESKO 200 MF4-R combines the advantage of a high voltage range up to 200 kV with a by a factor 3 smaller focal spot compared to Waygate Technologies conventional ERESKO MF4 radiation units.

This offers excellent penetration, sharper results and shorter exposures as well as geometric magnification inspection to facilitate higher productivity and quality in day-to-day inspection routines.

The X-ray tube head consists of a sturdy metal-ceramic X-ray tube and high voltage generator integrated into a rugged compact housing. The air-cooled 200 kV/ 600 W end-grounded X-ray tube is thermally protected for extended life.

The high voltage generator produces high-stability direct voltage at higher efficiency than conventional line frequency equipment.

The unit is designed for radioscopic applications respectively for applications with CR / Film where geometric enlargement is required.

The performance of the X-ray tube and the high voltage generator is continuously monitored for protection and operational safety. An on-board real time clock facilitates fully automatic warm-up routines for optimized and time-saving tube conditioning. The flexible connecting cable is heavy-duty and light weight.

The ERESKO series can also be controlled by PC or laptop and is compatible with the Waygate Technologies software Rhythm Insight RT.

Additional Features

- Rugged construction with proven reliability
- Extended operating range from 10 kV to 200 kV enables flexible use
- Gas insulated high voltage section reduces size & weight
- End-grounded, Be-window, metal-ceramic X-ray tube
- DC voltage operation
- Modern power electronics provides high stability
- On-board real time clock supports fully automatic warm-up
- Large 40° × 60° emergent beam
- Optimized air-flow cooling for efficient heat dissipation
- 100 % duty cycle at 30° Celsius (86° F)
- Built-in fail-safe warning lamp
- CE certification according to EMC and Low Voltage Directives
- Water / dust resistant in accordance with protection class IP65
- Produced under ISO 9001 certified quality management system

Standard Delivery Scope

ERESCO generator unit from high voltage generator and X-ray tube or optionally as a system with "ERESCO MF4 Control" control unit



Technical Data

X-ray tube type	200 kV metal-ceramic with Tungsten (W) anode
kV range	10 - 200 kV (acc. to rating chart)
Target angle	20°
Inherent filtration	0.8 mm ± 0.1 mm, Be
Emergent beam	40° × 60°, elliptical
Focal spot size (EN 12 543)	1.0 mm (~0.5 IEC 336)
Tube current	0.5 - 10 mA (3.0 mA /200 kV)
Anode temperature, max.	100° C
Current and voltage stability	± 1 %
Continuous rating	600 W
Power input, max.	1.0 kVA
Weight (exluding hand rings)	24.6 kg (54.2 lbs)
Tube head diameter	160 mm (6.3") (without rings)
Protection class	IP65
Operating Temperature	-20° C to +50° C
Storage Temperature	-30° C to +80° C

Options

- Carrying cradle
- Diaphragm / collimator attachments
- Laser centering device
- Transport and positioning cart
- Fail-safe flashing warning lamp
- Stands and mounting kits
- Aluminium transport box

Rating chart

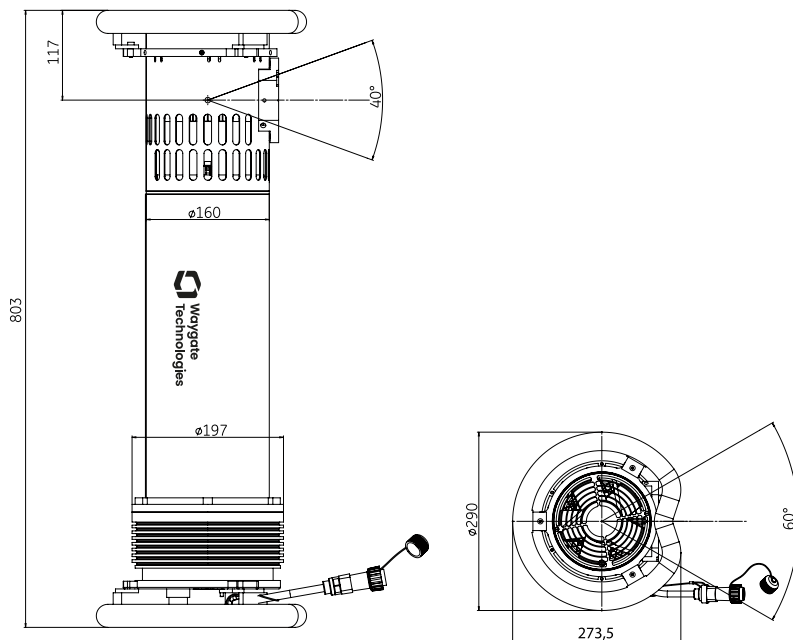
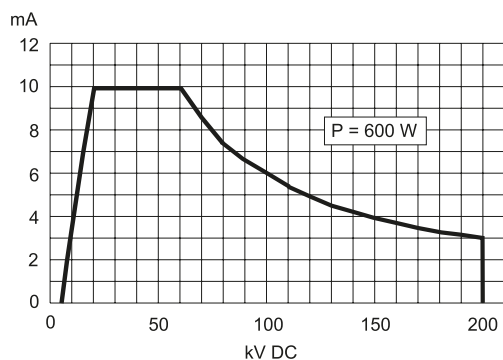

drawings not true to scale

Waygate Technologies
 Bogenstr. 41 • 22926 Ahrensburg / Germany
 Tel.: +49 4102 807 0 • Fax: +49 4102 807 189 • E-Mail: xray.info@bakerhughes.com

Copyright 2020 Baker Hughes Company. This material contains one or more registered trademarks of Baker Hughes Company and its subsidiaries in one or more countries. All third-party product and company names are trademarks of their respective holders.

BHFF30179EN (05/2023)

Baker Hughes 

waygate-tech.com