

# 60M100 Condition Monitoring System

## Datasheet

Cordant™

104M0791 Rev. H



## Description

The 60M100 Condition Monitoring System continuously monitors wind turbine machine trains using sophisticated signal processing algorithms and machine operating states. The 60M100 Monitoring System, as a part of condition-based maintenance, detects defects months in advance of a potential failure.

Depending on the size of your wind farm, early detection can reduce outages and production loss, saving you hundreds of thousands to millions of dollars per year in lost revenue. With the advanced knowledge provided by the 60M100, you can schedule maintenance outages and crane operations in advance, reducing maintenance costs.

The 60M100 Monitor can be used in several configurations:

- As an independent, standalone condition monitoring system.
- A networked, distributed collection of inter-operating systems.
- As an integrated part of a machine OEM's control and instrumentation package.

The 60M100 monitor includes features and advantages not provided in other systems. The monitor systems have all functionality required for condition monitoring of wind turbine machine trains including signal conditioning, alarming, configuration, speed inputs, and control system communication.

The system components include: 60M100 Monitor, Adapt.wind software, Transducers and cables.

Sophisticated signal processing algorithms extract dozens of measurements and health indices from each accelerometer point and can be custom tuned to specific bearing and gear box characteristics.



## 60M100 Overview

The 60M100 Condition Monitoring System is specifically designed for continuous permanent monitoring of wind turbine generator machine trains. It is designed to monitor equipment that requires extremely high reliability and availability.

The 60M100 System is designed to monitor essential characteristics and components of a wind turbine, including:

- Tower sway
- Main bearing
- Main rotor
- Gear boxes
  - All internal bearings
  - All bear meshes
  - Debris monitoring
- Generator bearings
- Generator grounding

If you need assistance configuring your monitoring solution, contact your local Bently Nevada sales professional or Bently Nevada support ([bntechsupport.com](http://bntechsupport.com)).

## Digital Communications

The 60M100 System includes digital communication capabilities for connection to ADAPT software using proprietary protocols via Ethernet connections. The 60M100 system transmits data via Ethernet TCP/IP. You can monitor values and status

your process and control and other automation systems.

provides extensive communication capabilities of all monitored values and statuses for integration with process control and other automation systems using Ethernet TCP/IP communications capabilities. It permits Ethernet communications with other 60M100 systems and System\_Software. Supported protocols include:

## Modbus/TCP

Industry standard Modbus protocol over TCP. The 60M100 supports both server and client mode.

## System Features

The 60M100 monitors 150 static variables producing high resolution waveform data and trendlines.

The 60M100 is a powerful and versatile Condition Monitoring system that provides basic monitoring functions and advanced signal processing and rules in a compact, robust unit. The module conditions the input signals to make various measurements and compares the conditioned signals with user-programmable alarms.

Capable of taking input from different sensor types, the 60M100 System can support up to 12 dynamic channel inputs, two Keyphasor signals, and digital communications. Channel 1 through channel 10 interface with 2-wire ICP type accelerometers. Channels 11 and 12 can be configured to interface with either 2-wire ICP type transducers or 3-wire proximity probes. Each dynamic channel can be independently configured with flexible signal processing options. The Keyphasor channels interface to either 3-wire proximity probes or other speed sensors which are powered externally.

The module provides enhanced capability for monitoring rolling element bearing machinery and gearing through its 24 bit Analog/Digital conversion and 40 kHz bandwidth design.

The 60M100 System is not a substitute for hard wired safety systems, nor does it replace the standard systems for the acquisition of operational data of the wind turbine.

## Specifications

### Electrical

Input Power	Min: 18 Vdc Max: 36 Vdc
Current	Max: 1.7 A
Inrush Current	Max: 2.7 A, less than 5 ms

### Module

#### Inputs

Max: 12 dynamic signals and 2 Keyphasor signals

Dynamic Range	110 dB @ fs = 102.4 ksps
Signal/Noise Ratio	110 dB @ fs = 102.4 ksps
A/D Conversion	Sigma-Delta 24 bits nominal
Bandwidth	0 to 40 kHz

#### Outputs

Two Independent Ethernet ports	Net A: 10/100 BaseT Network DHCP Port Net B: 10/100 BaseT Local Static IP Port
Buffered Signal Outputs	Two 15 pin DSUB connector 550 ohm output impedance

### LEDs

POWER LED	Indicates when a proper power input is present
OK LED	Indicates when the system is functioning properly.
Danger LED	Indicates an Danger Alarm condition
Alert LED	Indicates an Alert condition

Kph 1 OK LED	Indicates that Keyphasor signal 1 is triggering.
Kph 2 OK LED	Indicates that Keyphasor signal 2 is triggering.
NetA	Indicates that Network A has a valid link
TX/RX A	Indicates that network traffic is flowing on Network A
Net B	Indicates that Network B has a valid link
TX/RX B	Indicates that network traffic is flowing on Network B

### Accuracy

Direct pk or rms	Within $\pm 0.5\%$ of full-scale typical, $\pm 1.1\%$ worst case
Bias	+0.4 V / -0.8 V typical +0.8 V / -1.34 V worst case.
Rotor, Mesh and Fault Frequencies	$\pm 6.7\%$ typical, $\pm 9.7\%$ worst case
Bearing Frequencies	$\pm 6.7\%$ typical, $\pm 9.7\%$ worst case
Tower Sway	$\pm 0.16 \text{ m/s}^2$ (0.016 g) typical $\pm 0.23 \text{ m/s}^2$ (0.023 g) worst case
Kurtosis	$\pm 1\%$ 50 Hz to 10,000 Hz $\pm 3\%$ 1 Hz to 49.9 Hz
Generator Electrical Noise	$\pm 1\%$ 50 Hz to 10,000 Hz $\pm 3\%$ 1 Hz to 49.9 Hz
Crest Factor	Within $\pm 0.5\%$ of full-scale typical, $\pm 1.1\%$ worst case
-Minimum Amplitude for Crest Factor, Skewness, and Kurtosis measurements	0.6 $\text{m/s}^2$ (0.06 g)

## Alarming

Modes	Modes are determined from generator power: Mode 1: 25% to 40% power Mode 2: > 40% to 55% power Mode 3: > 55% to 70% power Mode 4: > 70% to 85% power Mode 5: > 85% power
Setpoints	2 levels: Warning and Alarm
Time Delay	300 seconds (fixed) for all measurements
Latching	All alarm statuses are latching

## Dynamic Data

Asynchronous Waveform	8192 samples, 320 ms
Synchronous Waveform	8192 samples: 4 revolutions, 2048 samples/rev 8 revolutions, 1024 samples/rev 16 revolutions, 512 samples/rev 32 revolutions, 256 samples/rev 64 revolutions, 128 samples/rev
Spectrums	
-Main Bearing	8 revolutions, 1024 samples/rev 3200 lines Sync Enveloped
-Gearbox Stages	3200 lines Sync Enveloped 3200 lines Sync High Res Number of revolutions and samples per revolution vary based on the selected asset.
-Generator Inboard / Outboard	64 revolutions, 128 samples/rev 3200 lines Sync Enveloped 3200 lines Sync High Res
-Tower Sway	15.625 Hz, 200 lines
Anti-Alias	-80 dB minimum

Update Rate	30 seconds
Historical Data Storage Rate	4 hours
Data Storage	2 weeks (typical, no alarms)

## Keyphasor Signal Inputs

Speed Range	1 to 120,000 rpm; limited to 2,000 rpm for wind turbines
Speed Resolution	1 to 100 rpm ± 0.1 rpm 100 to 2000 rpm ± 1 rpm
Gap	±8.2 mV typical ±22.3 mV worst case

## Supported Transducers

Acceleration Channels	TurningPoint TP100 Accelerometer
Keyphasor Channels	Turck Ni8-M18T-AP6X7M, externally powered Bently Prox Probes
Oil Particle Sensors	GasTOPs Macom
Proximity Channel (for Shaft Crack Detection)	Bently Prox Probe 3300 XL 11mm

## Environmental

Operating Temperature Range	-40 C to +70 C (-40 F to 158 F)
Storage Temperature Range	-45 C to +85 C (-49 F to 185 F)
Relative Humidity	0% to 95% non-condensing operating and storage
Pollution Degree	Pollution Degree 2 (working voltage < 30 Vrms or 60 Vdc)

## Physical

Dimensions	8.88 X 5.89 X 2.17 inches (225 X 150 X 55 mm) ( <a href="#">See 60M100 Monitor Overall Dimensions on page 9.</a> )
Weight	1.4 kg (3 lbs)
Mounting	DIN rail mounting

## Compliance and Certifications

### FCC

This device complies with part 15 of the FCC Rules. Operation is subject to the following two conditions:

- This device may not cause harmful interference.
- This device must accept any interference received, including interference that may cause undesired operation.

### EMC

EN 61000-6-2

EN 61000-6-4

EMC Directive 2014/30/EU

### Electrical Safety

EN 61010-1

LV Directive 2014/35/EU

### RoHS

RoHS Directive 2011/65/EU

### India - Battery EPR Marking

GE Oil & Gas India Private Limited

EPR Certificate No.: 1.1595372902047E+20

## Ordering Information



For the detailed listing of country and product specific approvals, refer to the *Approvals Quick Reference Guide* (108M1756) available from [Bently.com](http://Bently.com).

### Bently Nevada Wind Condition Monitor (Monitor Only)

#### 60M100-AA

##### A: Approvals

00	Standard
----	----------

### Bently Nevada Wind Condition Monitoring System Kit

#### 60M100\_KIT-AAA-BB

##### A: Configuration

<b>XX3</b>	GE 2.3-107 (Not available for order)
<b>XX4</b>	GE 2.5 MW PMG (Not available for order)
<b>020</b>	Vestas V82 (Not available for order)
<b>022</b>	Vestas V110/V110 After Market (Not available for order)
<b>026</b>	Vestas V110/V110 Factory Enclosure
<b>028</b>	Vestas 3MW Onshore (Not available for order)
<b>029</b>	Vestas 3MW MK3 (Not available for order)

##### B: Approvals

00	None
----	------

## Spares

### 3701 Software Package with Options 3701/00-AA-BB-CC

##### A: Order Type

<b>01</b>	Initial Purchase
<b>99</b>	Adapt.Wind Software Update DVD

##### B: Licensing

<b>00</b>	Update
<b>01</b>	200 Turbine Farm
<b>02</b>	33 Turbine Farm

##### CC: Software Version

<b>01</b>	Latest†
-----------	---------



†The 60M100 monitor is only compatible with software version 1.9 or later.

## Adapt.Wind Server and Monitor with Options 3701/11-AA-BB

### A: Server Computers

<b>00</b>	None
<b>01</b>	Hi Perf Tower
<b>02</b>	Hi Perf Rack
<b>03</b>	Workstation

### B: Monitors

<b>00</b>	None
<b>01</b>	22-Inch TFT Flat Panel

## Sensors and Cables

323394	Turningpoint TP100 Accelerometer 100 mV/g, 0.5 - 14,000 Hz
200355	Low Frequency Accelerometer 100 mV/g, 0.2 - 10,000 Hz
287844	Accelerometer Mounting Stud 1/4 -28 to M8x1.25 SST
284613-050	Accelerometer Cable, 15.2 m (50ft) with straight connector
284613-030	Accelerometer Cable, 9.1 m (30ft) with straight connector
284622-050	Accelerometer Cable, 15.2 m (50ft) with right angle connector
284622-030	Accelerometer Cable, 9.1 m (30ft) with right angle connector
138131	CAT5 Cable. Minimum cable length is 3 feet. Maximum cable length is 320 feet. Cable lengths are 3, 6, 10, 25, 40, 50, 75, 85, 100, 120, 150, 200, 250, and 320 feet.
323314-01	Buffered output cable, 15-pin DSUB to 7 SMA connectors

323314-02	Buffered output cable, 15-pin DSUB to 7 BNC connectors
122M4926	Right-angle mounted accelerometer 1200mV/g, 1.0 - 10,000 Hz

### Accessories

151M9812	Surge Protector
284005	Surge Protector Cover
104M4408-01	3701/60A to 60M100 Retrofit Mounting Kit
122M3999	Power Supply, 110/220 Vac to 24 Vdc 2.1 A DIN Rail Mount

### Miscellaneous

04425545	Grounding Wrist Strap (Single use only)
122M3999	Power supply, 100/220 Vac to 24 Vdc 2.1 A DIN rail mount

## Graphs and Figures

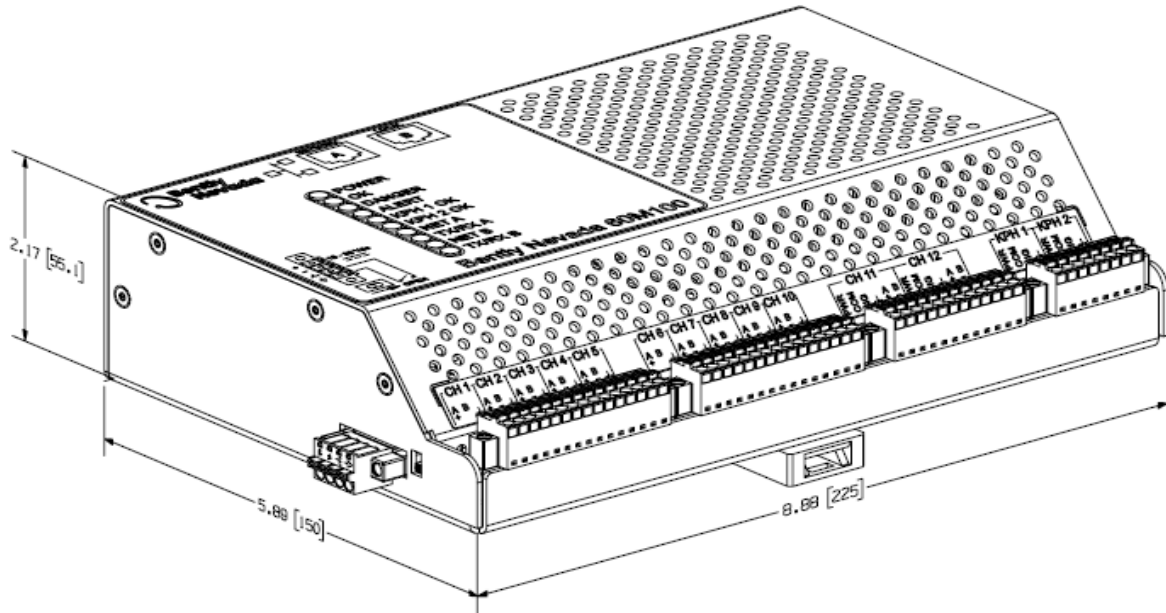

**Figure 1: 60M100 Monitor Overall Dimensions**

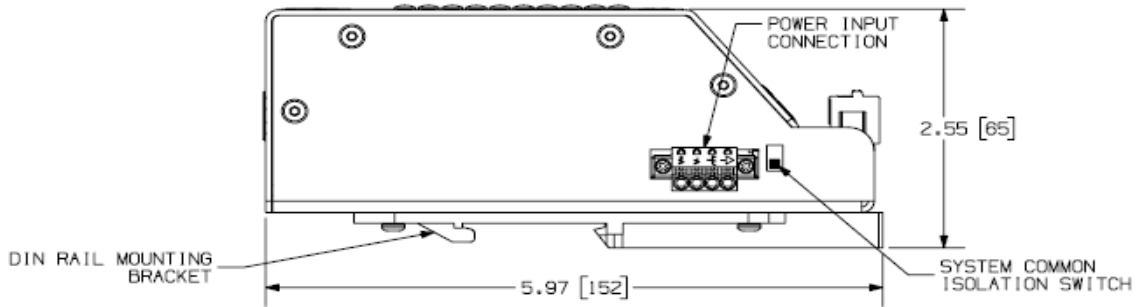

**Figure 2: 60M100 Monitor Side View**

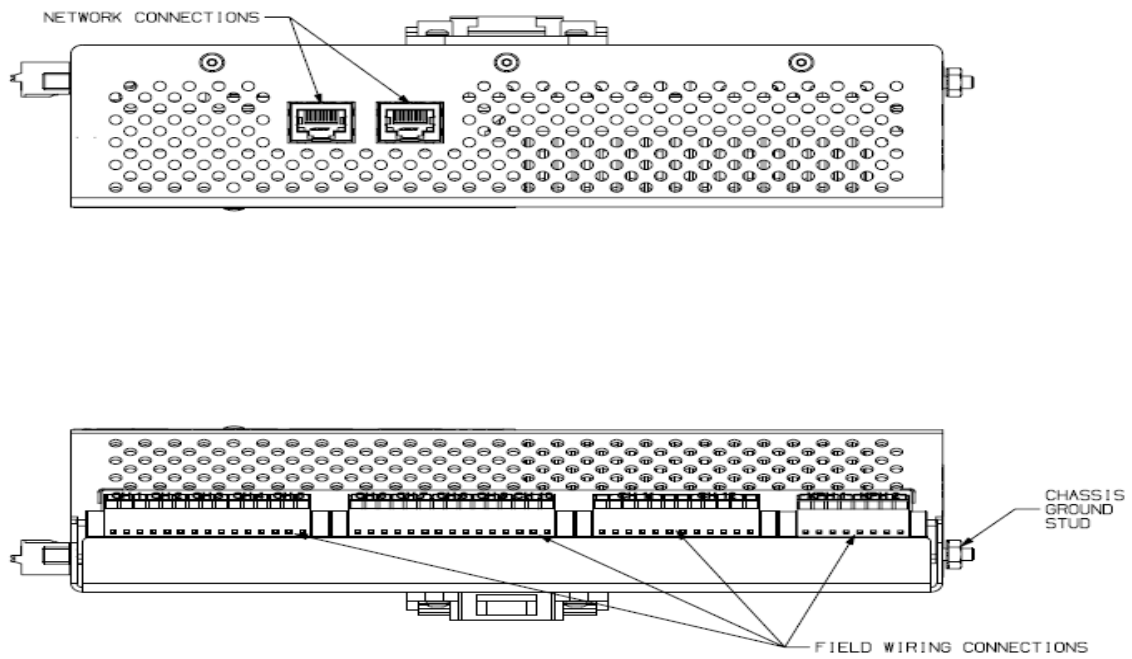

**Figure 3: 60M100 Monitor Top and Bottom Views**

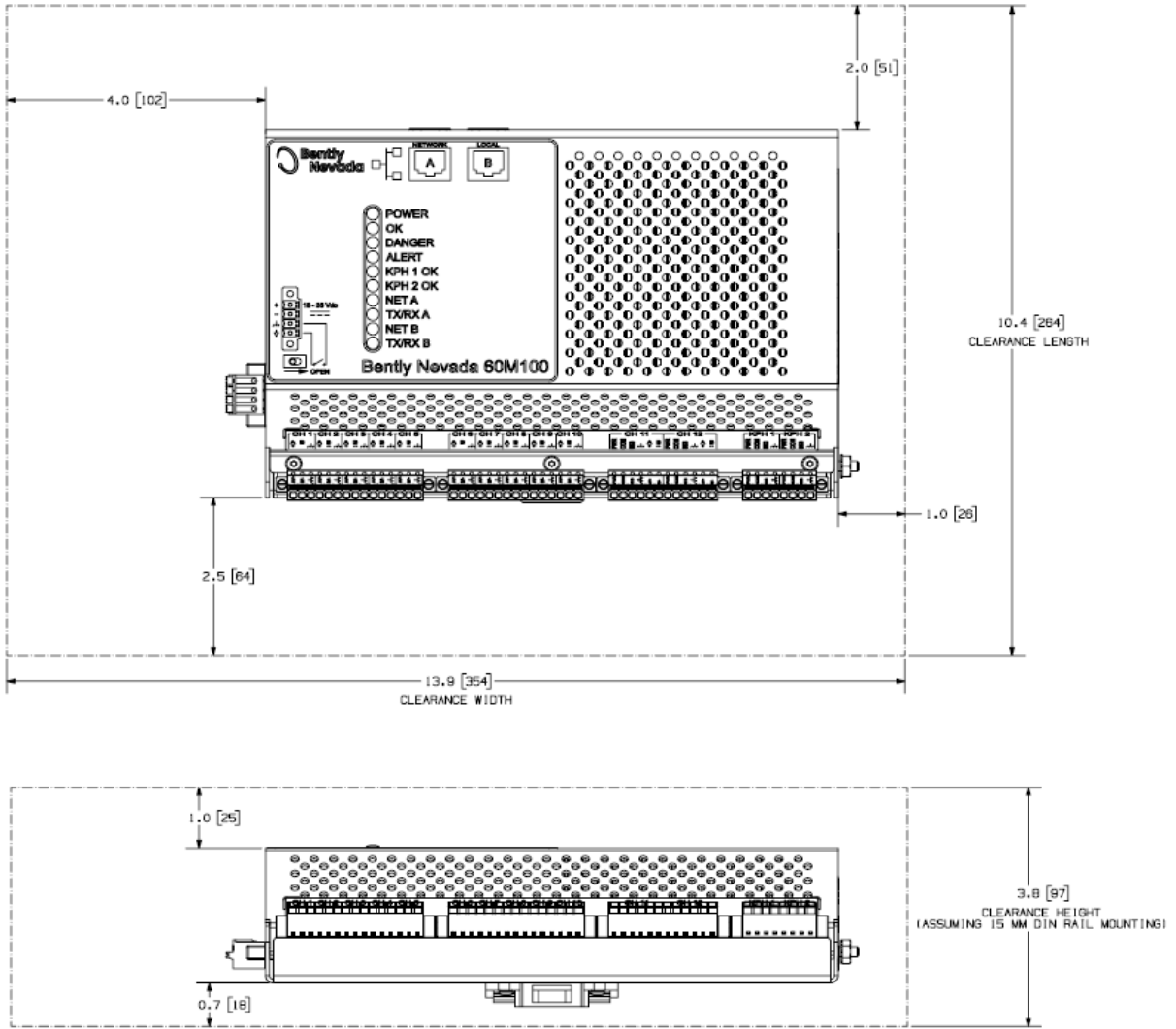

**Figure 4: Recommended minimum clearance window for cable terminations and monitor cooling**

Copyright 2026 Baker Hughes Company. All rights reserved.

Bently Nevada, a Baker Hughes Company  
1631 Bently Parkway South, Minden, Nevada USA 89423  
<https://bntechsupport.com>