

Flowgrid™ Regulator

Instruction Manual (Rev.F)

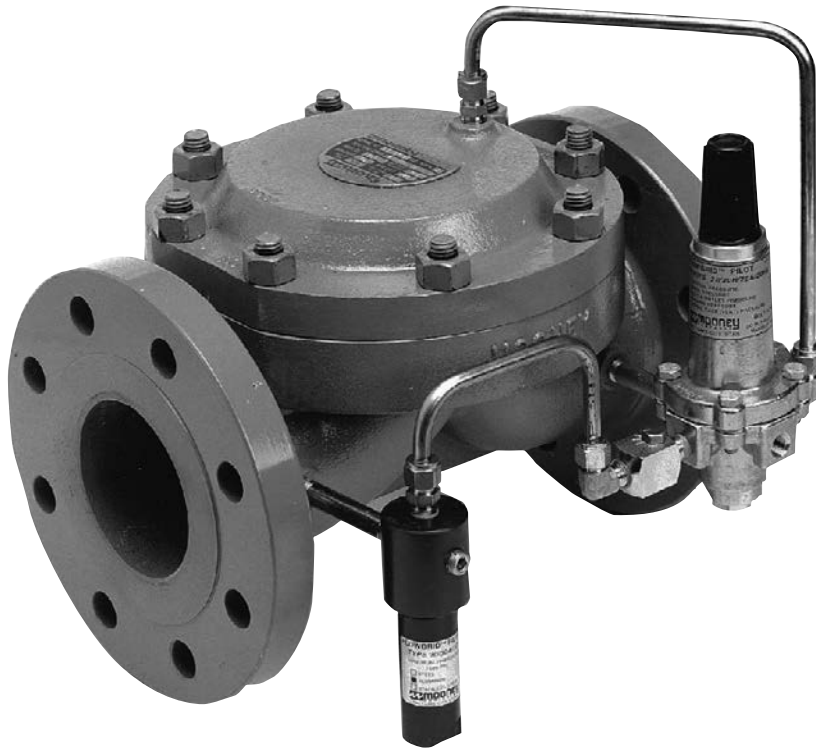

THESE INSTRUCTIONS PROVIDE THE CUSTOMER/OPERATOR WITH IMPORTANT PROJECT-SPECIFIC REFERENCE INFORMATION IN ADDITION TO THE CUSTOMER/OPERATOR'S NORMAL OPERATION AND MAINTENANCE PROCEDURES. SINCE OPERATION AND MAINTENANCE PHILOSOPHIES VARY, BAKER HUGHES COMPANY (AND ITS SUBSIDIARIES AND AFFILIATES) DOES NOT ATTEMPT TO DICTATE SPECIFIC PROCEDURES, BUT TO PROVIDE BASIC LIMITATIONS AND REQUIREMENTS CREATED BY THE TYPE OF EQUIPMENT PROVIDED.

THESE INSTRUCTIONS ASSUME THAT OPERATORS ALREADY HAVE A GENERAL UNDERSTANDING OF THE REQUIREMENTS FOR SAFE OPERATION OF MECHANICAL AND ELECTRICAL EQUIPMENT IN POTENTIALLY HAZARDOUS ENVIRONMENTS. THEREFORE, THESE INSTRUCTIONS SHOULD BE INTERPRETED AND APPLIED IN CONJUNCTION WITH THE SAFETY RULES AND REGULATIONS APPLICABLE AT THE SITE AND THE PARTICULAR REQUIREMENTS FOR OPERATION OF OTHER EQUIPMENT AT THE SITE.

THESE INSTRUCTIONS DO NOT PURPORT TO COVER ALL DETAILS OR VARIATIONS IN EQUIPMENT NOR TO PROVIDE FOR EVERY POSSIBLE CONTINGENCY TO BE MET IN CONNECTION WITH INSTALLATION, OPERATION OR MAINTENANCE. SHOULD FURTHER INFORMATION BE DESIRED OR SHOULD PARTICULAR PROBLEMS ARISE WHICH ARE NOT COVERED SUFFICIENTLY FOR THE CUSTOMER/OPERATOR'S PURPOSES THE MATTER SHOULD BE REFERRED TO BAKER HUGHES.

THE RIGHTS, OBLIGATIONS AND LIABILITIES OF BAKER HUGHES AND THE CUSTOMER/OPERATOR ARE STRICTLY LIMITED TO THOSE EXPRESSLY PROVIDED IN THE CONTRACT RELATING TO THE SUPPLY OF THE EQUIPMENT. NO ADDITIONAL REPRESENTATIONS OR WARRANTIES BY BAKER HUGHES REGARDING THE EQUIPMENT OR ITS USE ARE GIVEN OR IMPLIED BY THE ISSUE OF THESE INSTRUCTIONS.

THESE INSTRUCTIONS ARE FURNISHED TO THE CUSTOMER/OPERATOR SOLELY TO ASSIST IN THE INSTALLATION, TESTING, OPERATION, AND/OR MAINTENANCE OF THE EQUIPMENT DESCRIBED. THIS DOCUMENT SHALL NOT BE REPRODUCED IN WHOLE OR IN PART WITHOUT THE WRITTEN APPROVAL OF BAKER HUGHES.

Table of Contents

Product Description	1
Regulator Markings	3
Nameplate Information.....	3
Principles of Operation	4
Hydrostatic Testing	5
Installation.....	6
Piping Details.....	8
Start-up and Operation	12
Maintenance	15
Troubleshooting	16

Scope

This manual provides installation, operation, and maintenance instructions for the **Mooney™** Flowgrid regulator. Instructions for the Mooney Series 20 pilot and Mooney noise controller will be found in a separate manual.

Product Description

The Mooney Flowgrid regulator is an easy to maintain regulator designed to be used primarily with a self contained pilot system. The Flowgrid regulator has several unique features that add to its versatility such as:

- In line maintenance
- Replaceable trim
- Reversible trim parts
- Non stretching fabric reinforced diaphragm for stability and fast response at all temperatures
- Positive spring shutoff
- Two-stage pressure drop and optional noise controller to minimize noise and provide cavitation protection

Baker Hughes has secured global PED EN 334 certification for its Mooney Flowgrid regulators demonstrating our commitment to quality and safety. The certification was awarded by DVGW (the German Technical and Scientific Association for Gas and Water), one of the world's most recognized industry certification bodies and the largest gas and water industry certification agency in Europe. Baker Hughes has also secured the following verifications: ISO 9901, ISO 14001, CRN along with others ensuring the safety and quality of the Mooney regulator.

Materials of Construction

Body & Spring Case	ASTM A 216 WCB Carbon Steel
Spacer	ASTM A 216 WCB Carbon Steel
Throttle Plate	17-4PH Stainless Steel
Diaphragm	Nitrile/Nylon (Optional - Viton/Nylon)
O-Ring & Seals	Nitrile (Optional - Viton)
Bolting	ASTM 193 GR B-7 or Equal
Spring	301 Stainless Steel

Table 1

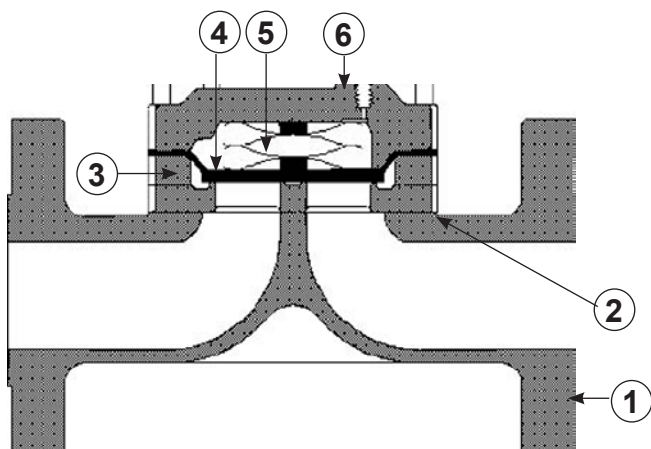

Figure 1 - Flowgrid Parts

All Mooney Flowgrid regulators have six main parts (excluding bolting and O-rings); the body, throttle plate, spacer, diaphragm, main spring, and spring case. Although parts vary in size and design, all regulators share the same principle of operation.

The **body (1)** is constructed with a single port (sizes less than 10") and a dual port (sizes greater than 10"). The dual port design can provide redundant control if equipped with dual pilots or be used with a single pilot for maximum capacity.

The **throttle plate (2)** supports the diaphragm and provides a machined surface that the diaphragm seals against for bubble tight shutoff. Restricted capacity plates of 35%, 50%, and 75% are available.

The **spacer (3)** creates a space between the throttle plate and the diaphragm which forms a flow path inside the regulator.

Specifications

Sizes	1" - 12" (DN 25 - DN300)
Body Style	Single Port 10 inch and 12 inch Dual Ports
End Connections	Screwed, Socket Weld Flanged, Flangeless & Buttweld
Temperature	-20°F to 150°F (-29°C to 66°C)
Min/Max Temperature	-40°F to 175° F (-40°C to 79° C)
Maximum Operating Differential	800 psi (55.16 bar)
Maximum Emergency Differential	1000 psi (68.9 bar) (unless limited by body rating)
Minimum Differential	Refer to individual product specification sheets
Cracking Differential	Refer to individual product specification sheets
Maximum Inlet Pressure	1480 psig (102.1 bar) (limited by flange or pilot rating)
Outlet Pressure Range	Limited by pilot
Flow Direction	Bi-Directional ¹
Body Taps	1/4" - 18 NPT

¹ Reverse flow by changing pilot connections and reversing spring case.

Table 2

The fabric-reinforced diaphragm (4) is the main working part of the Flowgrid regulator. The diaphragm functions as both an actuator and the regulator throttling element.

It is designed to provide stability, rangeability, and fast response without stretching. It will not "take a set" and is thick for durability and wear resistance.

The main spring (5) provides high frequency response, proportional action for stability and a consistent minimum differential regardless of temperature. It also provides a positive closing force, which is important in monitor regulation applications.

The spring case (6) is shaped to retain the main spring. It provides a low volume cavity where loading pressure from the pilot system is placed on top of the diaphragm to control flow through the regulator.

Regulator Markings

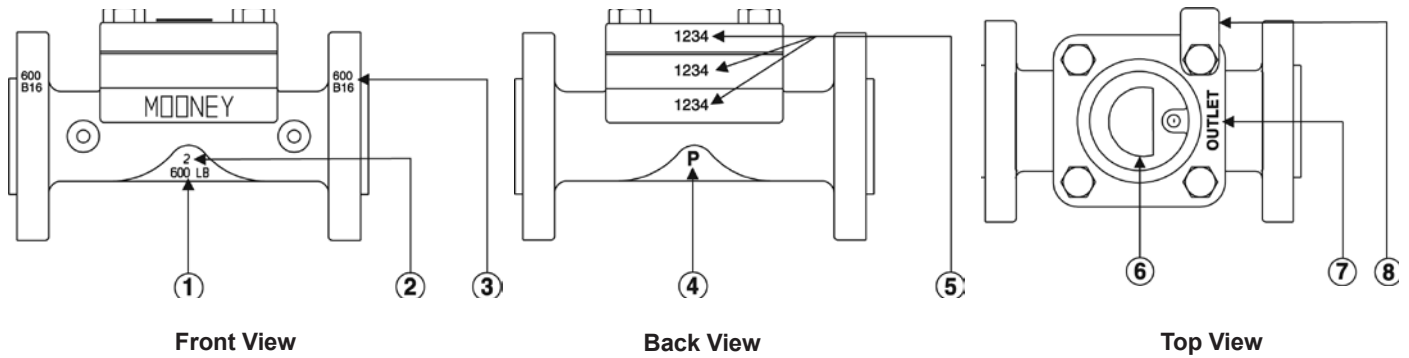

Figure 2 - Regulator Markings

1. American National Standards Institute (ANSI) pressure class rating of the regulator.
2. Line size of body.
3. ANSI pressure class rating of the flange.
4. Indication that the regulator has been hydrostatically tested according to code requirements.
5. The serial number is stamped on the spring case, spacer¹, and body.
6. The Nameplate location.
7. The flow direction is marked on the spring case (“INLET” or “OUTLET”). Proper alignment assures that the diaphragm guide on the Spring Case is aligned toward outlet side of the regulator.
8. The % Capacity tag indicates the capacity of the throttle plate (100%, 75%, 50%, & 35%) in the regulator.

¹ On all 1” regulators and 2” standard regulators the throttle plate itself is stamped.

Nameplate Information

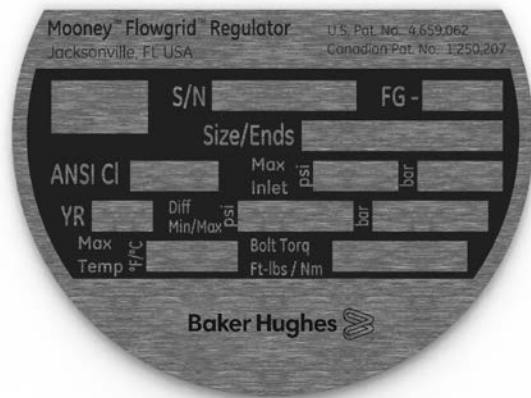

Figure 3 - Flowgrid Regulator Nameplate

Item	Definition
Flowgrid	Registered name of regulator
Blank	CE marking
S/N	Serial number assigned to regulator
FG	Flowgrid model description
Size/Ends	Line size of body and type of end connection
ANSI CI	American National Standards Institute pressure class
Max Inlet	Maximum inlet pressure (psig)/(bar)
YR	Year manufactured
Diff Min/Max	Minimum differential required to fully open regulator Maximum allowable operating pressure differential (psig)/(bar)
Max Temp	Maximum operating temperature in degrees Fahrenheit
Bolt Torq Ft-lbs/Nm	Recommended bolt torque for spring case in foot pounds

Table 3

Principles of Operation

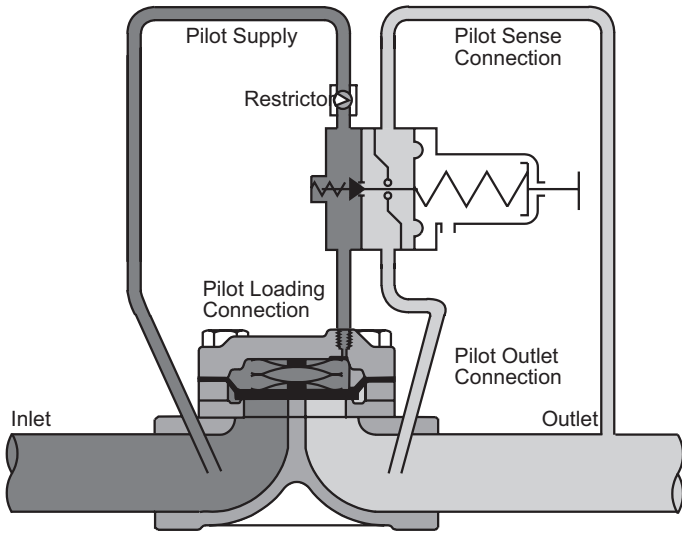

Figure 4 - Pressure Reducing Configuration Fully Closed

At no flow, when the outlet pressure is greater than the set point of the pilot regulator, the pilot is closed and full inlet pressure loads the spring case through the pilot loading connection. In this condition the diaphragm is closed tightly against the throttle plate. The pressure differential across the outlet half of the diaphragm adds to the spring force in closing the Flowgrid regulator (Refer to Figure 4).

As demand for flow occurs in the downstream system the outlet pressure drops, causing the pilot regulator to open and start bleeding pressure out of the spring case faster than it can enter through the restrictor. Reducing the pressure above the diaphragm allows the inlet pressure to progressively lift the diaphragm off the throttle plate, opening the regulator and satisfying the demand for flow in the downstream system. (Refer to Figure 5).

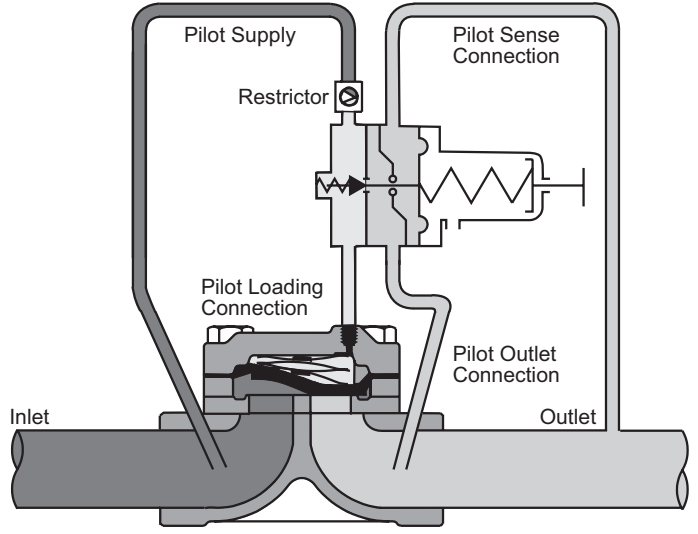

Figure 5 - Pressure Reducing Configuration Partially Open

When demand for flow ceases or is reduced, the downstream pressure increases causing the pilot regulator to close. Inlet pressure continues to pass through the restrictor until the control pressure equals the inlet pressure. The spring force, plus the pressure differential across the outlet half of the diaphragm closes the diaphragm against the throttle plate, shutting off the flow (Refer to Figure 4).

Adjustment of the restrictor affects the response rate, stability, and sensitivity of the regulator. Smaller restrictor openings result in higher gain (sensitivity) and slower closing speeds. Larger openings result in lower gain (greater proportional band), greater stability and faster closing speeds.

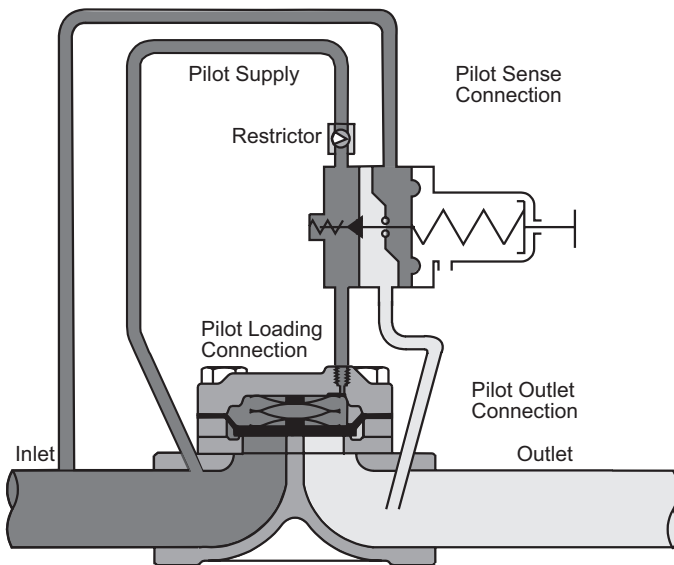

Figure 6 - Back Pressure Configuration Fully Closed

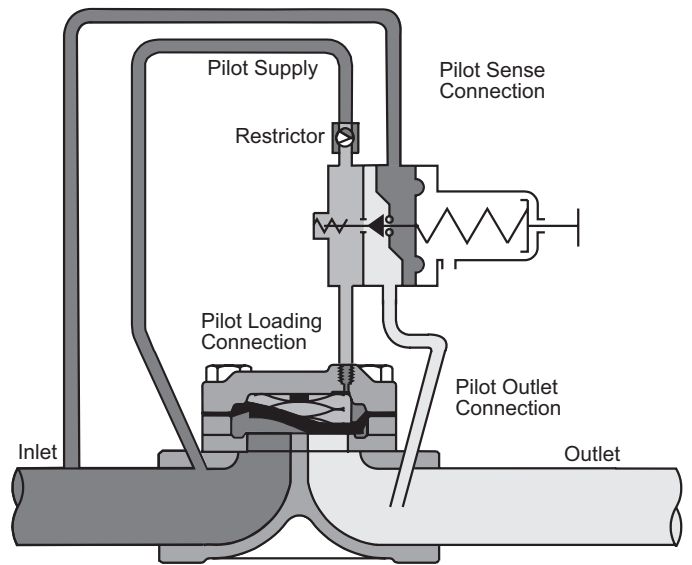

Figure 7 - Back Pressure Configuration Partially Open

A back pressure regulator or relief regulator controls upstream pressure instead of downstream pressure. The control action in the pilot is the reverse of a pilot for a pressure reducing regulator (increasing pressure in the sense chamber opens the pilot regulator). At no flow, when the inlet pressure is less than the set point of the pilot regulator, the pilot is closed and full inlet pressure loads the spring case through the pilot loading connection. In this condition, the diaphragm is closed tightly against the throttle plate. The pressure differential across the outlet half of the diaphragm adds to the spring force in closing the Flowgrid regulator (Refer to Figure 6).

As inlet pressure increases above the set point of the pilot regulator, it will open and start bleeding pressure out of the spring case faster than it can enter through the restrictor. Reducing the pressure above the diaphragm allows inlet pressure to progressively lift the throttling element off the throttle plate opening the regulator and satisfying the demand for flow in the upstream system (Refer to Figure 7).

When upstream pressure decreases, causing the pilot regulator to close, pilot supply pressure continues to pass through the restrictor until the control pressure equals the inlet pressure. The spring force, plus the pressure differential across the outlet half of the throttling element closes the diaphragm against the throttle plate, shutting off the flow (Refer to Figure 6).

Adjustment of the restrictor affects the response rate, stability, and sensitivity of the regulator. Smaller restrictor openings result in higher gain (sensitivity) and slower closing speeds. Larger openings result in lower gain (greater proportional band), greater stability and faster closing speeds.

Hydrostatic Testing

All Flowgrid regulators are hydrostatically tested at the factory prior to shipment according to ISA-S75.19-1989 and MSS-SP-61 standards. If it is necessary to retest the regulator, follow one of the procedures listed below to prevent damage to the diaphragm.

Option 1

1. Disconnect and remove all control line(s) and the pilot from the Flowgrid regulator.
2. Loosen main spring case nuts in a crisscross pattern. The main spring will lift the spring case as the nuts are removed.
3. Remove main spring and diaphragm from regulator.

For all 1", 2", 4", 6" (and 10"-V6) Flowgrid Regulators

4. Replace diaphragm with a used diaphragm that has the thick padded area cut out leaving the outer sealing surface (see below).



For 3" and 4" x 3" Flowgrid Regulators

4. Remove diaphragm but leave diaphragm O-ring in place. Make sure O-ring is properly seated.
5. Reassemble spring case on Flowgrid regulator.
6. Tighten main bolts in increments using a crisscross pattern. Torque bolting as indicated on regulator nameplate (or refer to Table 6, Page 14).
7. Plug spring case loading port, pilot inlet and outlet taps on Flowgrid regulator.
8. Refer to Table 4 for the maximum hydrostatic test pressure of each Flowgrid regulator.
9. After hydrostatic test is completed follow the Dissassembly, Cleaning, and Assembly procedures in the Maintenance section of this manual

Option 2

1. Disconnect and remove all control line(s) and pilot from the Flowgrid regulator.
2. Pipe regulator with the inlet, outlet, and loading connections all common so that pressure is equalized in the entire regulator during the hydrostatic test (See Figure 8).
3. Refer to Table 4 for Maximum hydrostatic test pressure of each Flowgrid regulator.
4. After hydrostatic test is completed follow the Disassembly, Cleaning, and Assembly procedures in the Maintenance section of this manual.

End Connection	Max. Hydrostatic Test Pressure
Screwed & Socket Weld	2225 psi (153.41 bar)
150# Flange & Flangeless	450 psi (31.02 bar)
300# Flange & Flangeless	1125 psi (77.56 bar)
600# Flange & Flangeless	2225 psi (153.41 bar)
Flowgrid 250 ¹	375 psi (25.86 bar)

¹ The Flowgrid 250 is a ductile iron construction.

Table 4 - Maximum Hydrostatic Test Pressures

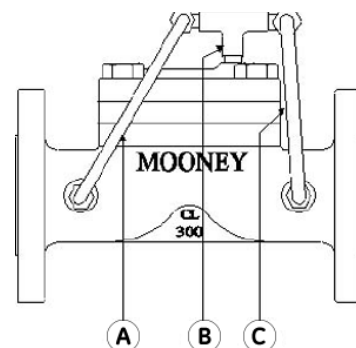

Figure 8 - Flowgrid Tee Connections

- A. Inlet connection on regulator body joined to "Tee".
- B. "Tee" connected to loading connection on spring case.
- C. Outlet of "Tee" connected to outlet connection on regulator

Installation

1. **Personnel:** Installation of the Flowgrid regulator should be made by qualified personnel familiar with high pressure piping and pilot operated regulators.

WARNING

Personal injury, equipment damage, or leakage due to explosion of accumulated gas or bursting of pressure containing parts, may result if this regulator is overpressured, or is installed where service conditions could exceed the limits given in the specification of this manual, or on the nameplate, or where conditions exceed any ratings of the adjacent piping or piping connections. Verify the limitations of both regulator and pilot to ensure neither device is overpressured. To avoid such injury or damage, provide pressure relieving or pressure limiting devices (as required by Title 49, Part 192, of the U.S. code of Federal Regulations, by the National Fire Codes of the National Fire Protection Association, or applicable codes), to prevent service conditions from exceeding those limits. Additionally, physical damage to the regulator/regulator could break the pilot off the main regulator, causing personal injury and/or property damage due to explosion of accumulated gas. To avoid such injury and damage, install the regulator in a safe location.

2. **Prior Inspection:** Inspect the main regulator, pilot, and tubing for any damage that might have occurred in shipping. Make sure the body, pilot lines, and inlet piping are clear and free from foreign material.
3. **Orientation:** The Flowgrid regulator may be installed in any position - the best position being one that provides easiest access for pilot adjustment and regulator maintenance.
4. **Lifting:** Recommended lifting points are provided with each Mooney Flowgrid regulator. A lifting bracket is included on the spring case of the 1-2" regulators and two eye nuts on the 3-6" regulators. When lifting Mooney Flowgrid Regulators, the following lifting guidelines are recommended:
 - Always lift from both supplied lifting points (Sizes 3" and larger) to ensure controlled and even lifting.
 - A minimum sling angle of 60° shall be used for lifting. It is recommended that a spreader bar be used to control lift angle when possible.
 - Never use a sling as a loop between two or more lifting eyes.
 - Always verify that lifting eye nuts are tightened until the base is flush with the top of the hex nut prior to lifting.
 - Never lift regulator assemblies by NPT ports in the body or spring case.
 - Never use accessories, accessory piping or fittings to lift or support regulator assembly.

WARNING

Flowgrid Regulators may require manual or assisted lifting. It is the end user's responsibility to ensure the lifting means (product lifting points or equipment) is properly installed, torqued, and inspected for use in accordance with local codes and standards. Sizes above 3" in weight and assemblies over 40 lbs, (18kg) require the use of another person or equipment aided lifting. When lifting or moving equipment suitable for an individual, added care should be taken to prevent extended or strained motion and positioning.

5. **Screwed End Regulators:** Apply pipe compound to the male threads starting one or two threads back from the end prior to assembling the joint.
6. **Flanged End Regulators:** Use suitable line gaskets and good bolting practices with flanged bodies. A crisscross pattern of incrementally tightening the line bolts is recommended.
7. **Weld End Bodies:** Remove the Spring Case and all trim parts including diaphragm and O-rings before welding a butt weld and/or a socket weld end Flowgrid regulator. Electric arc welding is recommended to minimize heat build-up on the body assembly. Reassemble regulator (refer to the Maintenance section of this manual for Disassembly and Assembly procedures) and pressurize with air to check for leaks prior to putting the regulator in service.

WARNING

Gas Regulators installed in confined or enclosed spaces should be provided with adequate ventilation to prevent the possibility of gas buildup or accumulation from leaks and venting. Leaks or vented gas may accumulate causing personal injury, death, or property damage. Pilot spring cases and the regulator enclosure should be vented to a safe area away from air intakes, or any hazardous location. The vent lines and stacks must be protected against condensation and clogging.

8. **Pilot Supply Lines:** Run a 3/8" or 1/2" pilot supply line from the regulator body connection on the inlet side of the Flowgrid regulator to the pilot supply Filter or directly to the pilot Restrictor.

Note: A shutoff regulator is not required in the supply to the pilot, but if one is installed it should be a full opening ball regulator type.
9. **A Type 30 Filter** in the pilot supply line is recommended to clean dirt and other particulates that could affect the restrictor or variable orifice in the pilot. Use a 1/4" nipple to mount the filter to the body tap on the Flowgrid regulator.
10. **Filter Outlet:** Run 3/8" tubing or 1/4" pipe from the filter OUTLET port to the INLET side of the restrictor in the pilot system of the regulator. The TYPE 30/30A/30S FILTER has two OUTLET ports for ease of tubing. Block the other port with the plug provided or mount a gage to monitor inlet pressure if desired.

Note: To avoid galling when stainless steel to stainless steel connections are made, use a lubricant (such as NEVER SEEZ by Bostik). For best results, Lightly lubricate the female threads. Mixing the lubricant with pipe dope is also acceptable. Do not exceed more than 1/4 turn past the point the threads start to bind.

Note: The Sense line (control line) connection should be 8-10 pipe diameters away from areas of turbulence (such as regulators, reducers, and elbows) and should have a full opening into the pipe free from burrs, drill peels, and weld slag. Shutoff regulators are not required in the control line(s), but if installed, they should be of the full opening type. Gas velocity at the sense line connection should not exceed 100 ft/sec (30m/sec).

11. **Pilot Gas Heaters (Optional):** Pilot supply gas can be heated to prevent the formation of ice or hydrates in the pilot system. Pilot supply gas heaters should be connected after the pilot filter (if one is used). Do not directly heat to entire Flowgrid regulator to prevent freezing; internal rubber components can be heated beyond their max temperature rating causing potential damage.
12. **Sense Lines (Control Lines):** Sense lines should be run from the pilot mounted on the Flowgrid regulator to a point 8 to 10 pipe diameters away from the regulator (Refer to Piping Schematics). Use Table 5 as a guide for the ideal tubing to use. Reduce as necessary to connect to the pilot.

13. **Pilot Discharge:** Run 3/8 inch tubing from the pilot OUTLET port to the downstream piping or to the connection provided on the outlet of the Flowgrid regulator as shown in the piping schematics.

Standby Monitor Note: To ensure full capacity of a Standby Monitor regulator station, it is important that the pilot discharge of the upstream regulator be connected downstream of the station if the minimum pressure drop (across the entire station) is below 60 psig (4.13 bar) (Refer to page 9 and page 12).

Outlet Pressure			
Pilot Regulator with:	Less than 2 psi (0.14 bar)	2 – 5 psi (0.14 – 0.35 bar)	Greater than 5 psi (0.35 bar)
Static Sense Line (No Flow) ¹	1/2" Pipe minimum	1/2" Tubing	3/8" Tubing
Sense Line w/ Flow ¹	3/4" – 1" Pipe	1/2" Pipe	1/2" Tubing

14. **Vent Regulators and Gauge Connections:** Vent regulators and gauge connections are recommended in the inlet and outlet piping to the Flowgrid regulator. A gauge connection may be installed on the loading pressure connection to the Spring Case of the Flowgrid regulator. These would be a great convenience during start up, maintenance, and operation.
15. **Interstage Piping (Working Monitor):** Please refer to page 10 for interstage piping and sense line connection recommendations.

¹The Flowgrid Series 20 Pilot has a static sense line.

Table 5 - Outlet Pressure

Piping Schematics

1. Single Port Regulator (PRV)
2. Single Port Regulator (BPV)
3. Dual Port Regulator/Single Pilot/(PRV)
4. Dual Port Regulator/Single Pilot/(BPV)
5. Dual Port Regulator/Dual Pilot/(PRV).
6. Dual Port Regulator/Dual Pilot/(BPV)
7. Standby Monitor with differential greater than 60 psig (4.13 bar)
8. Standby Monitor with differential less than 60 psig (4.13 bar)
9. Working Monitor

All drawings show installations with the Series 20 Flowgrid pilot equipped with Type 24 restricting regulator & Type 30 Filter. Consult factory for installation schematics of other manufacturer's pilot on the Flowgrid regulator.

1. Single Regulator/Single Pilot (Pressure Reducing Regulator)

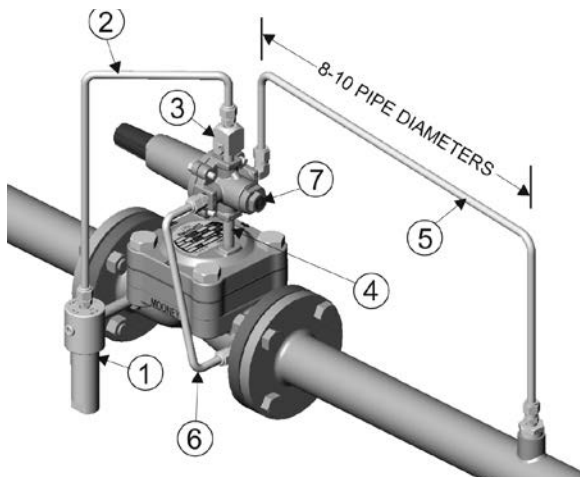

2. Single Regulator/Single Pilot (Back Pressure Regulator)

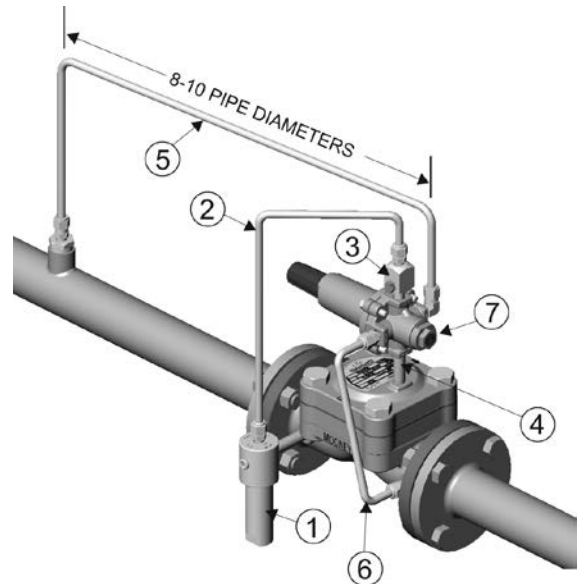

1. Filter supply connected from inlet connection on regulator body to Type 30 Filter inlet.
2. Pilot supply from outlet connection on Type 30 Filter to Type 24 Restrictor inlet.
3. Type 24 Restrictor mounted to Inlet port of Series 20 Pilot.
4. Loading Port of Series 20 Pilot connected to Loading connection on Spring Case of Flowgrid regulator.
5. Sense line connecting Sense port on Series 20 Pilot to upstream (BPV) or downstream (PRV) piping.
6. Outlet port of Series 20 Pilot connected to Outlet connection of Flowgrid regulator.
7. Pilot cartridge in PRV mode (pressure reducing) BPV (back pressure/relief) mode.

Piping Schematics (cont.)

3. Dual Port/Single Pilot (Pressure Reducing Regulator)

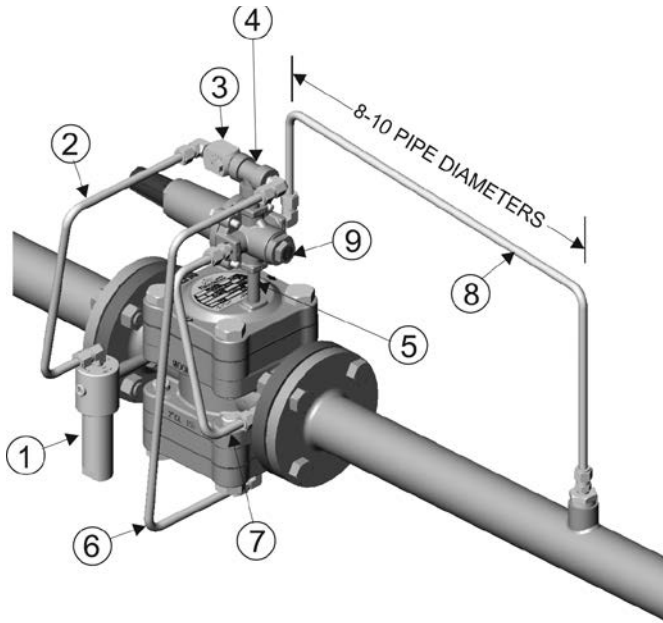

4. Dual Port/Single Pilot (Back Pressure Regulator)

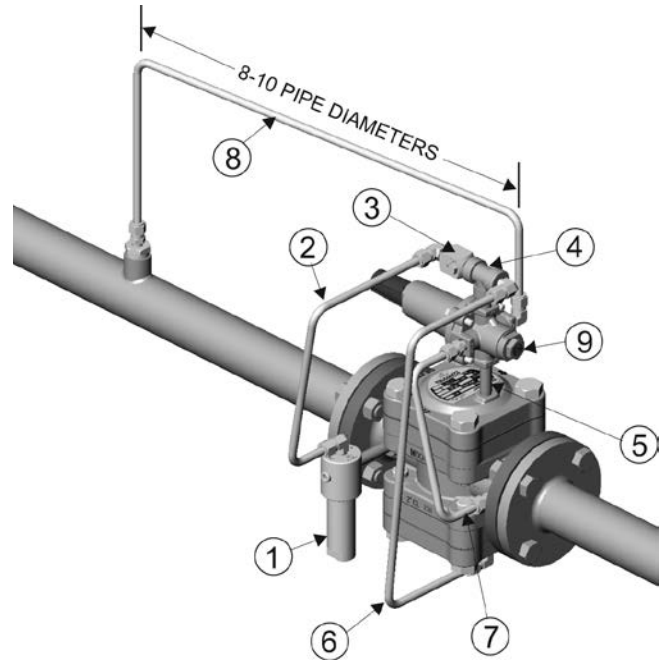

5. Dual Port/Dual Pilot (Pressure Reducing Regulator)

Note: The dual port regulator offers redundant control with two separate control loops. Ports #1 & #2 are piped identically.

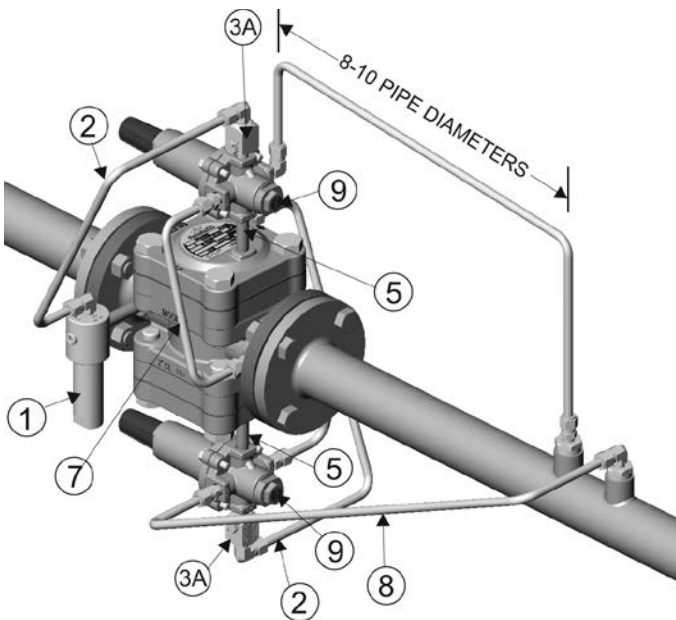

6. Dual Port/Dual Pilot (Back Pressure Regulator)

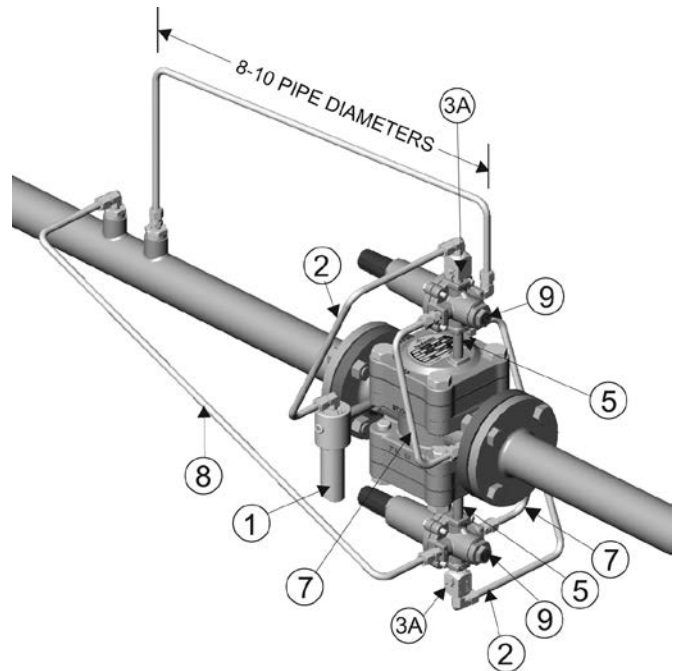

1. Filter supply connected from inlet connection on regulator body to Type 30 Filter inlet.
2. Pilot supply from outlet connection on Type 30 Filter to Type 24 Restrictor inlet.
3. Type 24 Restrictor mounted to "Tee" connection.
- 3A. Type 24 Restrictor mounted to Inlet port of Series 20 Pilot.
4. Tee mounted to Inlet Port of Series 20 Pilot.
5. Loading Port of Series 20 Pilot connected to Loading connection on Spring Case (Port #1) of Flowgrid Regulator.

6. From "Tee" to Spring Case (Port #2) of Flowgrid regulator.
7. Outlet port of Series 20 Pilot connected to Outlet connection of Flowgrid regulator.
8. Sense line connecting Sense port on Series 20 Pilot to downstream (PRV) or upstream (BPV) piping
9. Pilot cartridge in PRV mode (pressure reducing) BPV (back pressure/relief) mode.

Note: Dual port regulators in 1" - 8" sizes have been discontinued. Schematics for reference only.

Piping Schematics (cont.)

7. Standby Monitor with Differential Pressure Greater than 60 psi (4.13 bar)

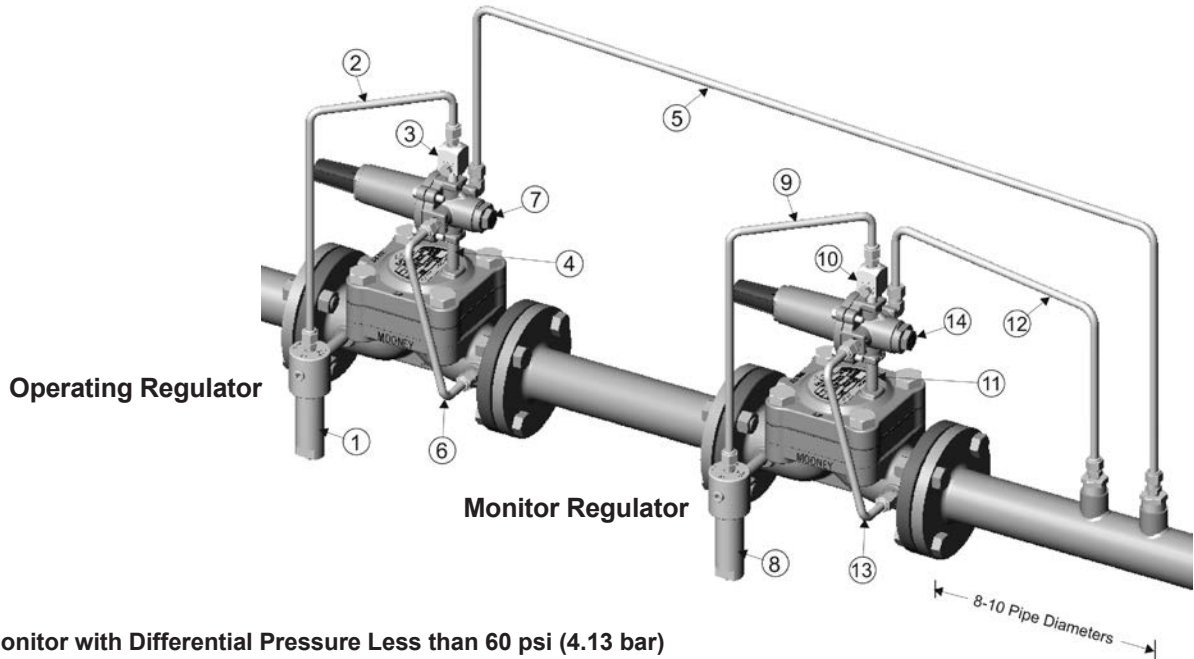

8. Standby Monitor with Differential Pressure Less than 60 psi (4.13 bar)

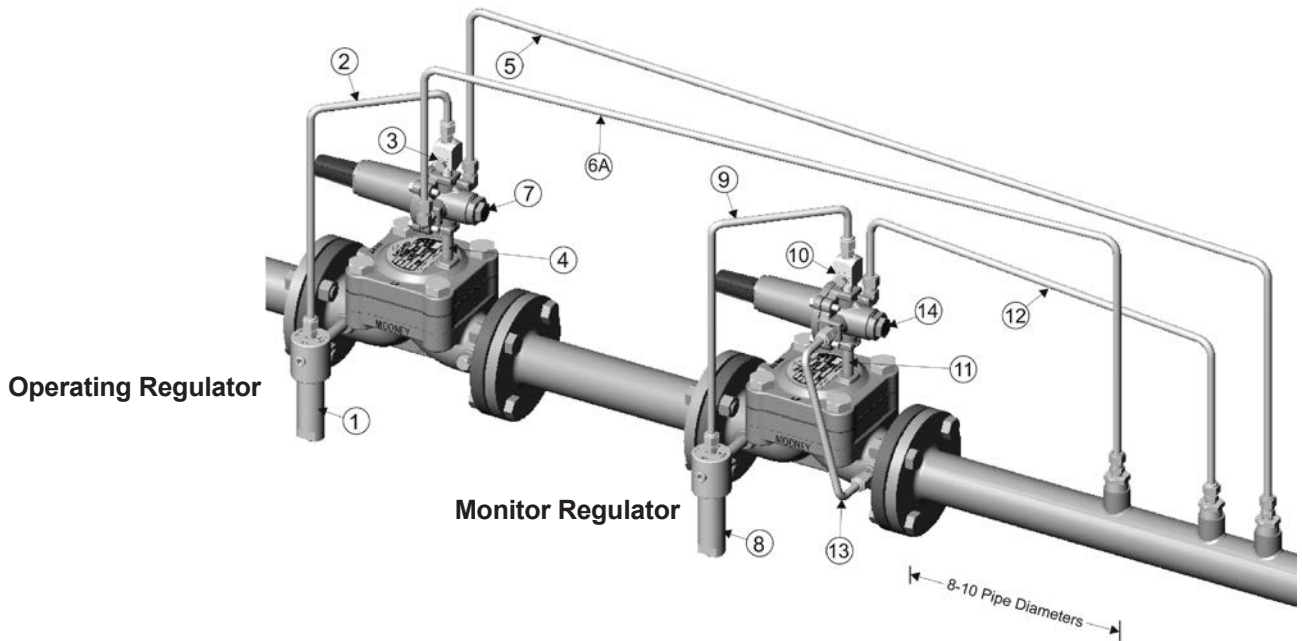

- | | |
|--|--|
| <ol style="list-style-type: none"> 1. Filter supply connected from inlet connection on regulator body to Type 30 Filter inlet. 2. Pilot supply from outlet connection on Type 30 Filter to Type 24 Restrictor inlet. 3. Type 24 Restrictor mounted to Inlet port of Series 20 Pilot. 4. Loading Port of Series 20 Pilot connected to Loading connection on Spring Case of Flowgrid regulator. 5. Sense line connecting Sense port on Series 20 Pilot to downstream piping. 6. Outlet port of Series 20 Pilot connected to Outlet connection of Flowgrid regulator. 6A. Outlet port of Series 20 Pilot connected to downstream piping. | <ol style="list-style-type: none"> 7. Pilot cartridge in PRV mode. 8. Pilot supply from inlet connection on regulator body to Type 30 Filter inlet. 9. Pilot supply from outlet connection on Type 30 Filter to Type 24 Restrictor inlet. 10. Type 24 Restrictor mounted to Inlet port of Series 20 Pilot. 11. Loading Port of Series 20 Pilot connected to Loading connection on Spring Case of Flowgrid regulator. 12. Sense line connecting Sense port on Series 20 Pilot to downstream piping. 13. Outlet port of Series 20 Pilot connected to Outlet connection of Flowgrid regulator. 14. Pilot cartridge in PRV mode. |
|--|--|

Piping Schematics (cont.)

9. Working Monitor (Refer to schematic on page 13)

General recommendations: To reduce the adverse effects on the sense signal due to high gas velocity and turbulence:

Pipeline diameters may need to be increased in pipe sections containing sense connections.

Gas velocity should be less than 100 ft/sec (30m/sec).

Sense connections should be 8-10 pipeline diameters away from turbulent areas.

Follow EN12186 piping specification.

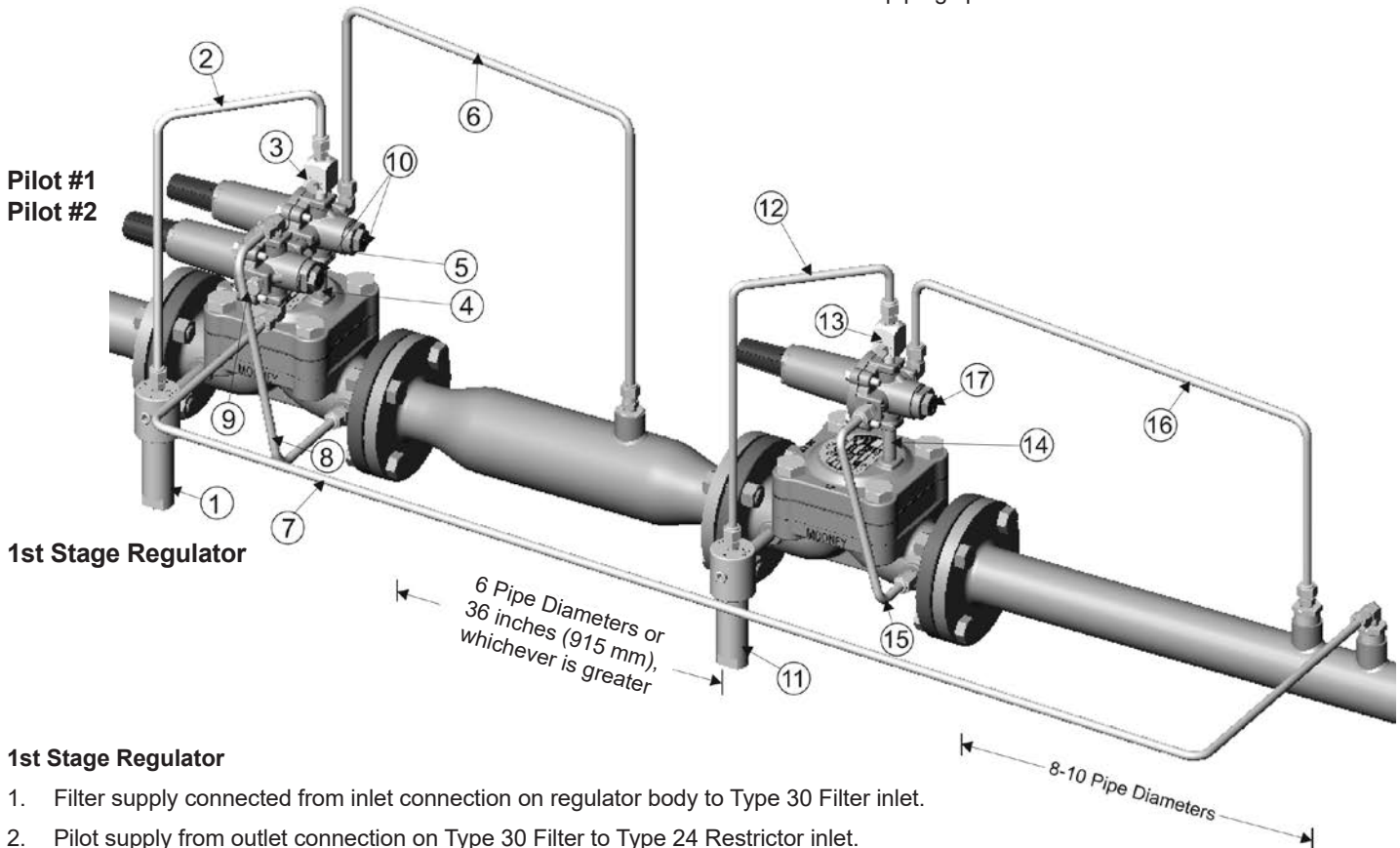

1st Stage Regulator

1. Filter supply connected from inlet connection on regulator body to Type 30 Filter inlet.
2. Pilot supply from outlet connection on Type 30 Filter to Type 24 Restrictor inlet.
3. Type 24 Restrictor mounted to Inlet port of Series 20 Pilot (#1).
4. Loading Port of Series 20 Pilot (#1) connected to Loading connection on Spring Case of the Flowgrid regulator.
5. Outlet port of Series 20 Pilot (#1) connected to Inlet port of the monitor Series 20 Pilot (#2).
6. Sense line connecting sense port on Series 20 Pilot to interstage piping.
7. Sense line connecting sense port on the monitor Series 20 Pilot (#2) to downstream piping.
8. Outlet port of Series 20 Pilot (#2) connected to Outlet connection of Flowgrid regulator.
9. Loading port on the monitor Series 20 pilot (#2) is plugged.
10. Pilot cartridges in PRV mode.

2nd Stage Regulator

11. Filter supply connected from inlet connection on regulator body to Type 30 Filter inlet.
12. Pilot supply from outlet connection on Type 30 Filter to Type 24 Restrictor inlet.
11. Pilot supply tubing from inlet connection on regulator body to Type 24 Restrictor inlet.
13. Type 24 Restrictor mounted to Inlet port of Series 20 Pilot (#3).
14. Loading Port of Series 20 Pilot (#3) connected to Loading connection on Spring Case of the Flowgrid regulator.
15. Outlet port of Series 20 Pilot (#3) connected to Outlet connection of Flowgrid regulator.
16. Sense line connecting Sense port on Series 20 Pilot (#3) to downstream piping.
17. Pilot (#3) cartridge in PRV mode.

Note: In a working Monitor system with less than 25 psig (1.72 bar) differential across the second stage regulator the pilot supply (11) may be connected to the piping upstream of the first stage regulator. This will improve the shutoff of the second stage regulator.

Start-up and Operation

The following procedures are suggested for start up of the Flowgrid regulator. Start up of the Flowgrid regulator should be made by qualified personnel familiar with high pressure systems and pilot operated regulators.

WARNING

The instruction manual for the PILOT(S) being used should be consulted to ensure that the installation and start up instructions for the pilot are followed. Some pilots can be damaged if not installed and put into operation correctly.

Pressure Reducing Regulator

1. Adjust the pilot restrictor to an intermediate opening (a “4” setting on the Mooney Type 24 Restrictor).
2. Back off on the pilot adjusting screw to fully relieve all the spring compression.
3. If installed, open hand regulator(s) in the control line(s), and the pilot supply line.
4. Slightly open downstream block regulator or open vent in piping downstream of the Flowgrid regulator.
5. Slowly open the upstream block regulator to pressurize the Flowgrid regulator and pilot system. The Flowgrid regulator should lock up (shut off) with zero pressure downstream.
6. Use vent in the downstream piping or slowly open the outlet block regulators.
7. Slowly increase the pilot spring setting until some flow is achieved through vent or into downstream system. Adjust the pilot restrictor for stability and performance as follows:
 - a. If the system is stable, adjust the pilot restrictor to a more closed position (towards MIN setting). Change the flow rate or increase the pilot setting to check the operation of the system during an upset.
 - b. If the system is stable, repeat step (a) until the system is unstable (oscillating).
 - c. Now readjust the restriction to a more open position (towards MAX setting) where the system is stable.
 - d. Vary the flow rate over as wide a range as possible to make sure the system will be stable under all flow conditions.
8. Slowly increase the pilot spring setting until the desired downstream pressure is achieved.
9. Slowly close the downstream block regulator or vent to check the Flowgrid regulator for lockup (shut off).

Note: Adjustment of the restrictor affects the response rate, stability, and sensitivity of the regulator. CLOSING the pilot restrictor (moving adjustment towards MIN setting) will result in higher gain (narrow the proportional band), more sensitivity, and slower closing speeds. OPENING the pilot restrictor (moving the adjustment towards MAX setting) will result in less gain (widen the proportional band), less sensitivity, and faster closing speeds.

10. Slowly open the downstream block regulator. to begin normal operation

Back Pressure Regulator or Relief Regulator

1. Adjust the pilot restrictor to an intermediate opening (a “4” setting on the Mooney Type 24 Restrictor).
2. Increase pilot spring compression to maximum or some margin above desired setting.
3. If installed, open hand regulators(s) in the control line(s), and the pilot supply line.
4. Check that the Flowgrid regulator is vented to atmosphere or the downstream system is ready to accept flow.
5. Open the downstream block regulator or open vent in piping downstream of the Flowgrid regulator.
6. Slowly open the upstream block regulator to pressurize the Flowgrid regulator and pilot system.

The Flowgrid regulator should lock up (shut off) with zero pressure downstream.
7. Slowly decrease the pilot spring setting until some flow is achieved. The flow may only be through the pilot system.
8. Adjust the pilot restrictor for stability and performance as follows:
 - a. If the system is stable, adjust the pilot restrictor to a more closed position (towards MIN setting). Change the flow rate or increase the pilot setting to check the operation of the system during an upset.
 - b. If the system is stable, repeat step (a) until the system is unstable (oscillating).
 - c. Now readjust the restriction to a more open position (towards MAX setting) where the system is stable.
 - d. Vary the flow rate over as wide a range as possible to make sure the system will be stable under all flow conditions.
9. Slowly adjust the pilot spring setting until the desired upstream pressure (relief setting) is achieved.

Note: Adjustment of the restrictor affects the response rate, stability, and sensitivity of the regulator.

CLOSING the pilot restrictor (moving adjustment towards MIN setting) will result in higher gain (narrow the proportional band), more sensitivity, and slower closing speeds. OPENING the pilot restrictor (moving the adjustment towards MAX setting) will result in less gain (widen the proportional band), less sensitivity, and faster closing speeds.

Standby Monitor

Note: This procedure is based on the 1st Regulator being the operating regulator and the 2nd regulator being the monitor regulator.

1. Set operating pilot (#1) spring at the MAXIMUM setting.
2. Set monitor pilot (#2) spring to the MINIMUM (zero) setting.
3. Purge station and open outlet regulator or vent to allow flow through the station
4. Slowly open inlet block regulator. Full inlet pressure should be present at the Monitor Regulator and the Monitor Regulator should be closed.
5. Increase the pilot spring setting of the Monitor Regulator until the desired monitor override setting is reached. Lock in pilot setting.
6. With some flow going through the station, begin to lower the operating pilot setting of the Operating Regulator until the desired outlet pressure is achieved.

Note: When the set point of the Operating Regulator becomes less than the set point of the Monitor regulator, the interstage pressure will drop from approximately full inlet pressure to 5-10 psi (0.35 - 0.68 bar) above the outlet pressure at low flow rates.

Checking Standby Monitor Operation

1. With flow going through the station, slowly increase the setting of the Operating Regulator. When the pressure reaches the setpoint of the Monitor Regulator, the monitor should take control and the interstage pressure should increase to almost full inlet pressure.
2. Reduce the setting of the Operating Regulator back to the required outlet pressure. The interstage pressure should drop to 5-10 psi (0.35 - 0.68 bar) above the outlet pressure as the Operating Regulator takes control.

Note: When the differential across the entire station (P1-P2) is less than 60 psig (4.13 bar) then alternate outlet piping as shown below, is recommended for added station capacity. This applies to the Series 20 Pilot only; consult with Baker Hughes for applicability to other manufacturer's pilots.

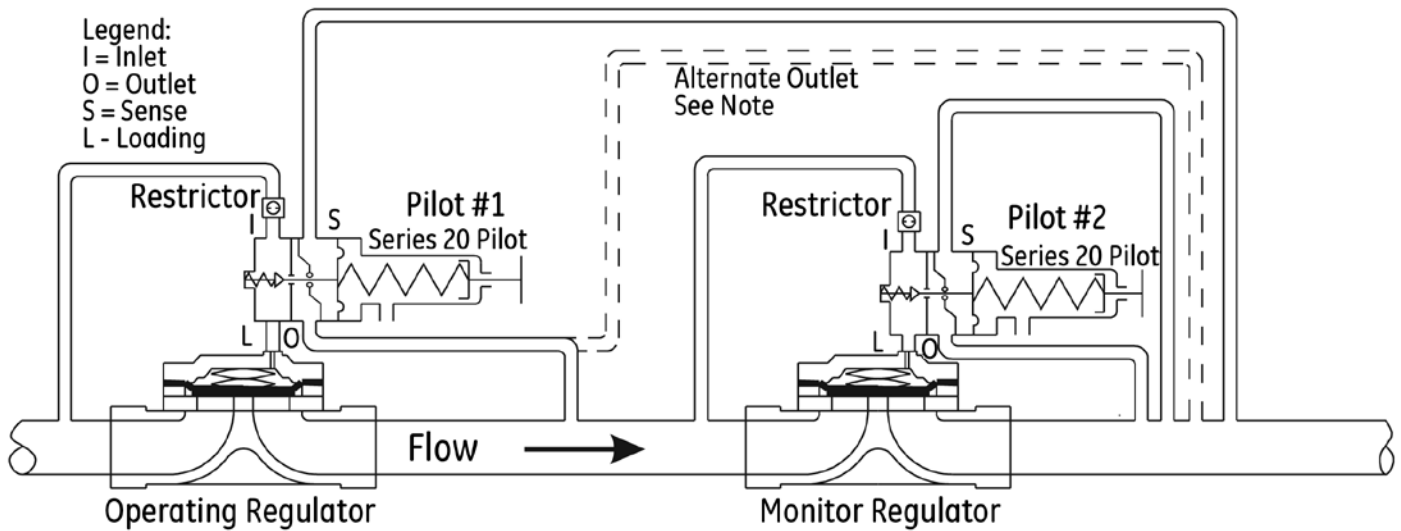

Figure 9 - Standby Monitor Schematic

Standby Monitor

Working Monitor

1. Purge station and open outlet regulator or vent to allow flow through the station.
2. Set pilot (#3) to a high setting above desired setpoint.
3. Set pilot (#1) to a high setting above desired setpoint.
4. Set the Monitor pilot (#2) at a zero setting.
5. Set restrictor on Pilot (#1) at an intermediate opening (a "4" setting on the Mooney Type 24 Restrictor).
6. Slowly open the inlet block regulator to station. The 1st Stage Regulator should remain closed as a result of the Monitor Pilot (#2) being set to zero.
7. Increase the setting of the Monitor Pilot (#2) to the desired pressure setting. If the regulator is unstable, increase the restrictor opening until it becomes stable.

8. Lower the setpoint of the 2nd stage regulator (Pilot #3) to the desired outlet pressure setting. Tune the restrictor on Pilot (#3) at this time. The 1st stage regulator should open or begin to control the interstage pressure at the setpoint of Pilot (#1).
9. Adjust the setpoint of Pilot (#1) to achieve the desired Interstage pressure. Tune the restrictor on Pilot (#1) at this time.
10. Raise the setpoint of Pilot (#3) to verify the setpoint of the Monitor Pilot (#2). Adjust if necessary. Check for system stability and adjust the restrictor on Pilot (#1) if required.
11. Return setpoint of Pilot (#3) to maintain the desired outlet pressure.

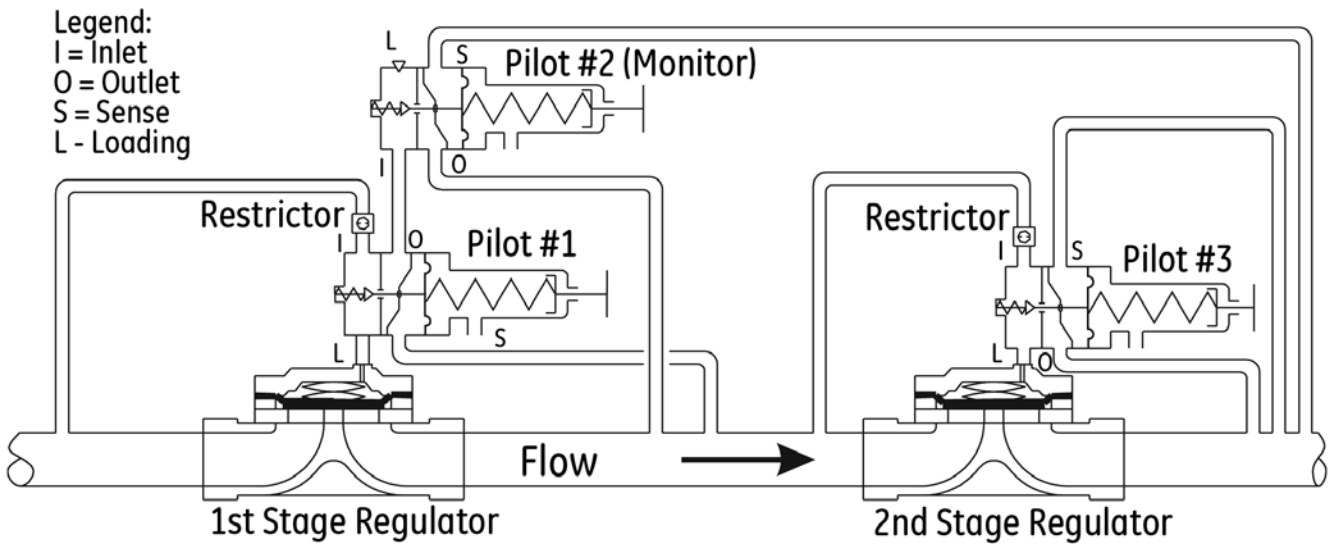

Figure 10 - Working Monitor Schematic

Note: In a working Monitor system with less than 25 psig (1.72 bar) differential across the second stage regulator the pilot supply may be connected to the piping upstream of the first stage regulator. This will improve the shutoff of the second stage regulator.

Maintenance

Regulator parts are subject to normal wear and must be inspected and replaced as necessary. The frequency of inspection and replacement of parts depends on severity of service conditions or the requirements of local, state, and federal regulations. Be certain that the name plates are updated to accurately indicate any field changes in equipment, materials, service conditions, or pressure settings.

Before disassembly make sure the regulator has been isolated from the process by closing block regulators on the inlet and outlet sides of the regulator. Safely release pressure and process fluid from body and pilot system. Failure to complete these steps can result in personal injury and property damage.

Assembly

1. Disconnect control lines(s) and pilot supply line from pilot system.
2. Loosen main spring case nuts in a crisscross pattern. The main spring will lift the spring case as the nuts are removed.
3. Remove spring, diaphragm/throttling element, spacer, throttle plate and O-rings in that order.
4. Inspect all parts for wear and damage. Replace as necessary.

Note: The periphery of the downstream (outlet) portion of the throttling plate is the primary shutoff surface and should be inspected most closely for wear and damage. Nicks and/or wear on the support ribs will usually not affect shutoff.



The outside “rib” on the downstream side of the throttle plate is where shutoff takes place in the Flowgrid Regulator.

Note: Nitrile O-rings can swell after disassembly of a regulator that has been in service (due to gas permeating the nitrile rubber). This does not necessarily mean they must be replaced. Set O-ring aside for several hours and it will gradually return to normal size. Placing the O-ring(s) on ice will speed the process considerably. Before placing the O-ring back into service inspect for defects.

Cleaning

1. DO NOT clean O-ring grooves with sharp metal tools. The bottom of the groove must have a smooth finish to prevent leakage. The mating surface of adjacent parts must also be smooth to prevent leakage.

Assembly

Note: Do not lubricate diaphragm sealing surface.

1. Reassemble parts on the body per the assembly drawing in the parts supplement for the particular regulator size.

Note: Both the throttle plate and the diaphragm can be rotated 180 degrees (not turned upside down) to renew the shutoff capability if the inlet side is in better condition than the outlet.
2. Tighten main bolts in increments using a crisscross pattern. Torque bolting as indicated on regulator nameplate (or refer to Table 6).

Bolting Torque Values

Clean Dry Bolts- Non-Lubricated

Regulator Size	Min. Torque Ft/Lbs (n-m)
Flowgrid 250	20 (27.09)
1" (ALL) ¹	25 (33.86)
2' x 1" (ALL) ¹	25 (33.86)
2" (ALL) ¹	60 (81.26)
3" (ALL) ¹	125 (169.28)
4" x 3" (ALL) ¹	125 (169.28)
4" (ALL) ¹	125 (169.28)
6" CL 150 & CL 300 Flanged	125 (169.28)
6" CL 600 Flanged	200 (270.86)
10" CL 150 & CL 300 Flanged	125 (169.28)
10" CL 600 Flanged	200 (270.86)
12" CL 150 & CL 300 Flanged	125 (169.28)
12" CL 600 Flanged	200 (270.86)
All Flowgrid Pilots	10 (13.54)

¹ Refer to WARNING below.

Table 6

! WARNING

Overtightening the bolting can damage the diaphragm in the 1" and 2" sizes of the Flowgrid regulator.

! WARNING

DO NOT replace the studs or nuts with any bolt or stud and nut combination that does NOT have an SAE Grade 7 or ASTM Grade B7 rating.

3. Reconnect the pilot system. Follow Start up procedures when returning to operation.

Troubleshooting

First Steps

1. Verify the regulator specifications fit the application conditions.

Min/max inlet pressure, control pressure range & min/max operating differentials should be checked to make sure the regulator and pilot are designed to operate in the present conditions.

2. Verify the regulator is piped correctly.

Even though the regulator may have operated in the past, check that current piping connections match recommendations on pages 7-10.

3. Verify the regulator is sized correctly.

Regulators operating below 10% or above 80% of their maximum capacity given current application conditions tend to have more problems. Consider reduced capacity trim or a larger regulator in these cases.

Potential Issues

Regulator does not shut off.

1. Refer to the failure mode chart to diagnose potential causes.
2. Clean or replace regulator and pilot components as necessary.

Erratic Control.

1. Check for damage, debris in the restrictor and control pilot. Replace, clean and lubricate components as necessary. Consider pilot supply filtration (Type 30 Filter).
2. Check for the potential of hydrate formation or freezing liquids in the pilot system. If liquids are present consider gas conditioning before the pilot and/or regulator, heating the supply gas to the regulator, or heating the pilot supply gas (pilot gas heater).
3. Check the sense line location and assure it is away from turbulent locations. Moving the sense line to a new location often solves control problems.
4. Check to make sure needle regulators are not used on any pilot system connections. Full opening type such as ball regulators are recommended.
5. Check for pilot vent port blockage.

Instability & Speed of response issues.

1. Change restrictor setting. Refer to page 11.
2. Check the sense line location and assure it is away from turbulent locations. Moving the sense line to a new location often solves control problems. Factory recommendation is 8-10 pipe diameters away from sources of turbulence such as tee's, elbows, reducers, regulators, etc.
3. Check to make sure needle regulators are not used on any pilot system connections. Full opening type regulators are recommended.
4. Check for pilot vent port blockage.

The regulator will not regulate to set point or “droops-off”.

1. Check for proper sizing. The regulator may be running out of capacity during peak demand periods.
2. Adjust the restrictor to a higher gain (smaller) setting. Refer to page 11.

The regulator fails open or fails closed.

1. Refer to the table below to diagnose failure modes.

Problem	Failure Mode	
	Fail Open	Fail Closed
Damage to the flexible element	X	X
Damage to the flexible element on the upstream side (less likely)		X
Damage to the flexible element on the downstream side (more likely)	X	
Debris between the flexible element and the seat	X	
Blockage of pilot supply pressure	X	
Blockage ¹ of the restrictor	X	
Blockage ¹ of the pilot supply line	X	
Loss of the sense line (PRV pilot)	X	
Loss of the sense line (Relief Pilot)		X
Blockage ¹ of pilot discharge		X
Pilot diaphragm rupture if (PRV pilot)	X	
Pilot diaphragm rupture if (BPV relief pilot)		X
Blockage ¹ of pilot orifice		X

¹ Blockage can be caused by debris, hydrates, freezing or damage to the component involved.

Table 7

Find the nearest local Channel Partner in your area:

valves.bakerhughes.com/contact-us

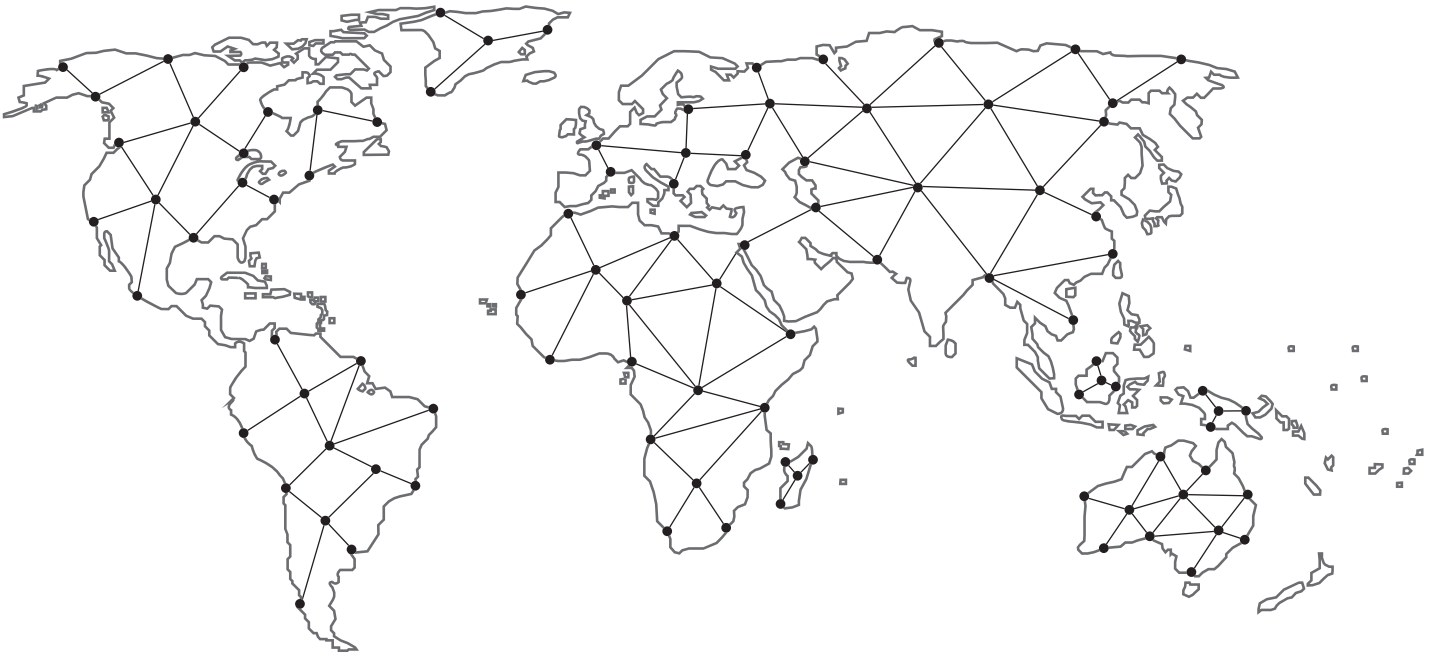

Tech Field Support & Warranty:

Phone: +1-866-827-5378

valvesupport@bakerhughes.com

valves.bakerhughes.com

Copyright 2023 Baker Hughes Company. All rights reserved. Baker Hughes provides this information on an "as is" basis for general information purposes. Baker Hughes does not make any representation as to the accuracy or completeness of the information and makes no warranties of any kind, specific, implied or oral, to the fullest extent permissible by law, including those of merchantability and fitness for a particular purpose or use. Baker Hughes hereby disclaims any and all liability for any direct, indirect, consequential or special damages, claims for lost profits, or third party claims arising from the use of the information, whether a claim is asserted in contract, tort, or otherwise. Baker Hughes reserves the right to make changes in specifications and features shown herein, or discontinue the product described at any time without notice or obligation. Contact your Baker Hughes representative for the most current information. The Baker Hughes logo, Flowgrid and Mooney are trademarks of Baker Hughes Company. Other company names and product names used in this document are the registered trademarks or trademarks of their respective owners.

