

# RK 4 Model Rotor Kit

## Datasheet

Cordant™

141592 Rev. P

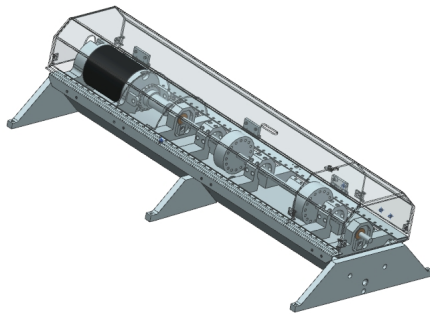

## Description

The RK 4 Rotor Kit closely simulates actual rotating machine behavior. Its unique geometry and its ability for users to isolate and control individual machine characteristics make it useful as both a teaching aid and as a research and development tool.

Machine malfunctions and experiments that can be demonstrated include, but are not limited to:

- Rotor unbalance - both single plane and multiplane
- Shaft rub condition
- Oil whirl and oil whip instabilities

In addition to machinery behavior, the rotor kit can be used to teach the fundamentals of proximity probe placement, gapping, and troubleshooting. It can also help technicians learn how to read and interpret proximity probe signals using an oscilloscope.

## Performance and Features

The RK 4 Rotor Kit has a V-frame design that has been developed to provide better control of the housing dynamic stiffness properties. The mechanical tolerances have also been tightened, resulting in more accurate machine behavior modeling. The RK 4 Rotor Kit motor can closely hold the desired speed with changes in loading conditions. This has been accomplished by incorporating a direct current motor and high performance control circuitry. The motor can run in either a clockwise or counter-clockwise direction and has adjustable slow roll speed capability. It can be controlled remotely by using a  $\pm 5$  volt control input, such as a signal generator or dc power supply, to drive the motor speed

control device. Rotor speed is displayed on a digital tachometer with a large LCD readout.

The RK 4 Rotor Kit consists of:

- A mechanical base (including motor, coupling, rotor shaft, two balance wheels, two journal bearings and bearing blocks, six proximity probes, three probe mounts, a rub screw, and three safety covers).
- A Proximator assembly that contains five Proximator units.
- A direct current motor speed control device.

The motor speed control device provides power for both the rotor kit and the Proximator assembly. A measurement and diagnostic tool, such as an oscilloscope or other diagnostic instrument, should be ordered separately in order to observe the RK 4 machine behavior.

An optional Oil Whirl/Whip kit can be ordered.

The Oil whirl kit consists of:

- A high pressure oil pump assembly.
- An oil whirl bearing assembly.
- A rotor kit shaft with oil bearing journal.
- A load frame.

Fluid-induced instabilities (both oil whirl and whip) as well as basic journal bearing behavior can be demonstrated using the oil whirl/whip kit. The oil whirl bearing is made from transparent plastic, allowing the user to view the oil film development during operation. The load frame is used to remove the effect of gravity on the rotor and to position the rotor to any desired eccentricity ratio.

The kit includes:

- A mechanical base (including motor, coupling, drive assembly, drive belts, and two proximity probes for motor speed control and Keyphasor signal pickup).
- A motor speed control unit.

## Specifications

### Basic Rotor Kit

Power	95 to 125 Vac, single phase, or 190 to 250 Vac, single phase, 50 to 60 Hz at 3.0 A maximum.
Fuse Rating	250 V at 3 A slow-blow.
Buffered Proximitors Assembly Outputs	200 mV/mil.
Max Speed	10,000 rpm, typical.
Max Ramp Rate	±15,000 rpm/min. typical.
Mechanical Base Dimensions	
Height	165 mm (6.5 in)
Width	340 mm (13.4 in)
Depth	789 mm (30.8 in)
Motor Speed Control Dimensions	
Height	115 mm (4.5 in)
Width	260 mm (10.3 in)
Depth	325 mm (12.8 in)
Proximitors Assembly Dimensions	
Height	86 mm (3.4 in)
Width	154 mm (6.1 in)
Depth	158 mm (6.2 in)
Shaft diameter	10 mm (0.4 in)
Environmental	
Operating Temperature	25° C ± 10° C (77° F ± 18° F) 95% RH Non-condensing Recommended indoor use only.

### Weight

Rotor Kit Base	14.5 kg (32 lb)
Proximitors Assembly	0.9 kg (2 lb)
Motor Speed Control	2.7 kg (6 lb)

### Oil Whirl/Whip Kit

Oil Pump Power	95 to 125 Vac, single phase 50 to 60 Hz at 1.5 A maximum; or 190 to 250, single phase, 50 to 60 Hz at 0.75 A maximum. User-selectable input voltage.
Oil Pump Fuse Rating	95 to 125 Vac 250 V 3.0 A slow-blow 190 to 250 Vac 250 V 1.5 A slow-blow User-selectable fuse

### Oil Pump Dimensions

Height	145 mm (5.7 in)
Width	317 mm (12.5 in)
Depth	292 mm (11.5 in)

## Ordering Information



For the detailed listing of country and product specific approvals, refer to the Approvals Quick Reference\_Guide (108M1756) available from [www.Bently.com](http://www.Bently.com).

### Rotor Kit

#### 123456-AA

##### A: Oil Whirl/Whip Kit

<b>00</b>	Not required
<b>01</b>	Required

### Accessories

#### Manuals

126376	RK 4 Rotor Kit
137482	Oil Whirl/Whip Kit

#### Safety Cover Replacement Parts (refer to Figure 1)

106M5920	Main Cover
106M5918	Small End Cover
106M5916	Speed Wheel Cover
106M5917	End Cap Cover (for use with fluid bearing only)
105M7924, 105M7930, 106M8448, and 106M8449	Lock Mechanism
105M7923 and 105M7929	Polycarbonate Screw (need quantity of 3 each)
105M7931	Rubber Bumper (need quantity of 3)

04312254 (16), 168614 (16), and 105M7925 (4)	Cover Hinge Set
Spare Power Cords	
02198937	USA 10A/250V 3-wire
285300	Brazil 10A/250V 3-wire
Spare Probes	
330903- 00-03-10- 02-00	Spare 3300 NSv Probe, M8X1, without armor (Vibration, Keyphasor probes)
330903- 00-02-10- 02-00	Spare 3300 NSv Probe, M8X1, without armor (Speed Probe)
Additional Oil Whirl/Whip Option	
126379	Oil Whirl/Whip Kit

## Graphs and Figures

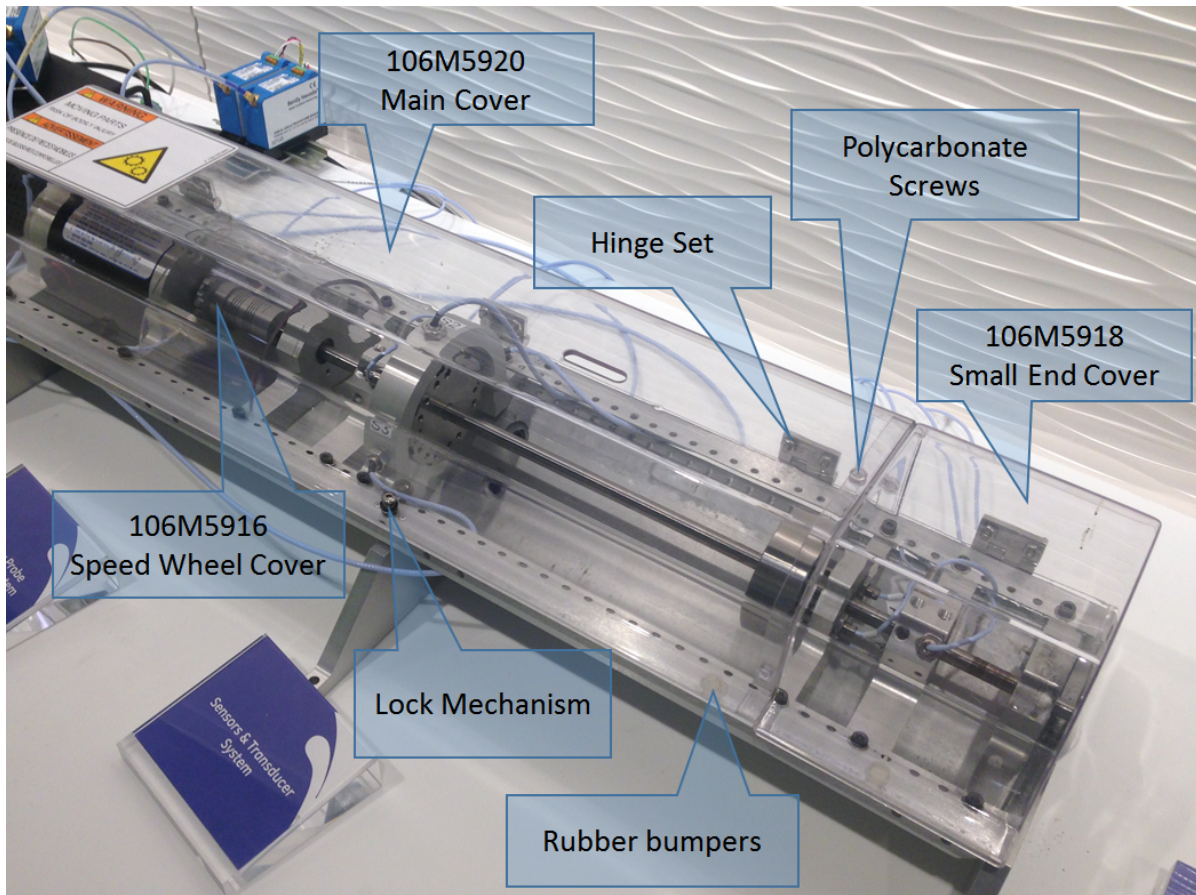

**Figure 1: Rotor Kit**

Copyright 2025 Baker Hughes Company. All rights reserved.

Bently Nevada, a Baker Hughes Company  
1631 Bently Parkway South, Minden, Nevada USA 89423  
<https://bntechsupport.com>