



DPS5000 I2C

Digital pressure sensing platform

The new DPS5000 I2C from Druck, part of the UNIK5000 family, offers integrated digital electronics to enhance the performance level of the UNIK 5000 Pressure Sensing Platform to levels unmatched by traditional analogue sensors. It features an I2C digital interface, over which fully compensated readings of pressure and temperature are sent, as well as control of many functions of the device.

High quality

With 40 years of pressure measurement experience, our field-proven Druck technology is at the heart of the new platform, resulting in a range of high quality, high stability pressure sensors.

Bespoke as standard

Custom-built from standard components, manufacturing sensors to your requirements is fast and simple; each UNIK 5000 is a “bespoke” pressure sensing solution, but with the short lead times and competitive pricing you would expect from standard products.

Expertise

We have the people and the knowledge to support your needs for accurate and reliable product performance; our team of experts can help you make the right sensor selection, guiding you and providing the help and tools you need. It is important that you ensure that the sensor materials and performance selected are suitable for your application.

Features

- Ranges from 70 mbar to 100 bar
- Total accuracy to $\pm 0.1\%$ FS
- Stainless steel construction
- 3 V supply voltage
- Low power
- I2C digital output
- Sleep mode
- Hazardous area certifications
- Excellent long-term stability

DPS5000 I2C specifications

Operating pressure ranges

Gauge ranges

Zero-based ranges

- 70 mbar
- 200 mbar
- 350 mbar
- 700 mbar
- 1 bar
- 2 bar
- 3.5 bar
- 7 bar
- 10 bar
- 20 bar
- 28 bar
- 35 bar
- 70 bar
- 100 bar

Absolute ranges

Calibrated ranges

- 0.8 to 3 bar
- 1 to 7 bar
- 2 to 12 bar
- 3 to 28 bar
- 5 to 40 bar
- 10 to 70 bar
- 18 to 90 bar
- 15 to 100 bar

Units continue to give readings down to zero pressure absolute.

Over pressure

- 2 × pressure range for absolute ranges
- 4 × pressure range for gauge ranges

Containment pressure

- 6 × pressure range for gauge ranges (200 bar maximum)
- 200 bar for absolute ranges

Supply

Supply voltage

2.7 to 3.6 Vdc

Current consumption

- <50 µA standby
- <2 mA average during acquisition

Output/communications

I2C slave device, 100 kHz maximum data rate

Power-on time

30 ms to acquisition from standby

Insulation resistance

500 Vdc ≥ 100 MΩ

Performance

Pressure performance

Calibrated accuracy over the calibrated temperature range including zero and span setting and the effects of non-linearity, hysteresis and repeatability.

Gauge reference

±0.1 % FS

Increases pro-rata for pressure ranges below 700 mbar

Absolute reference:

±0.2 % of reading (RDG) over calibrated range

Temperature performance

Accuracy over the operating temperature range ±3°C

Long term stability

- ±0.05 % FS/year typical
- ±0.1 % FS/year maximum
- ± 0.2% FS/5 year maximum (via special design consult factory)

All values at reference conditions

Increases pro-rata for pressure ranges below 700 mbar

Physical specifications

Environmental protection

- Internal version – not applicable
- External version – IP68 to 700 mH2O

Operating temperature range

- -40°C to +85°C (-40°F to +185°F)
- -40°C to +80°C (-40°F to +176°F) for FM intrinsically safe version

Pressure media

- Fluids compatible with stainless steel 316L and Hastelloy C276.
- Statement in accordance with the European pressure equipment directive.
- Refer to document K0581 for product classification and regulatory information.

Enclosure materials

Stainless steel (body)

Pressure connectors

- PA G1/4 female
- PB G1/4 male flat
- PE 1/4 NPT female
- PF 1/4 NPT male
- PG 1/8 NPT male
- PZ M10 x 1.0 80° int cone

Other connectors may be available. Contact Druck to discuss your requirement.

Electrical connector

Option code	Description	IP rating
0 Internal	None (flying leads)	-
3 External	Polyurethane cable	IP68 to 700 mH ₂ O

Wiring details

Option 0 internal		Option 3 external	Function
Pin	Color		
1	Red	Red	Supply +ve
2	Yellow	Orange	I2C SDA
3	Green	Black	I2C SCL
4	Blue	White	0 V
5	Orange	Yellow	Do not connect
6	Black	Blue	Do not connect
-	-	Screen	Case

CE conformity (external version only)

- RoHS 2011/65/EU
- Pressure equipment directive 2014/68/EU sound engineering practice
- ATEX 2014/34/EU (optional)
- EMC Directive 2014/30/EU
- BS EN 61000-6-1: 2007: susceptibility - light industrial
- BS EN 61000-6-2: 2005: susceptibility - heavy industrial
- BS EN 61000-6-3: 2007+A1:2011: emissions - light industrial
- BS EN 61000-6-4: 2007+A1:2011: emissions - heavy industrial
- BS EN 61326-1: 2013: electrical equipment for measurement, control and laboratory use
- BS EN 61326-2-3: 2013: particular requirements for pressure transducers

Hazardous area approvals

External version (apparatus)

- ATEX Ex II 1G
- IECEx Ex ia IIC T4 Ga (-40°C ≤ Ta ≤ 80°C)
- FM approvals (Canada & US) Intrinsically Safe Ex ia
- Class I, Zone 0, AEx/Ex ia Group IIC, T4, single seal
- INMETRO Ex ia IIC T4 Ga

Internal version (component)

- ATEX Ex II 1G
- IECEx Ex ia IIC Ga
- INMETRO Ex ia IIC Ga

General certifications

- RoHS 2011/65/EU
- CRN certified of 13650.513467890YTN for pressure ranges up to and including 100 bar.

Ordering information

Select part number

Main product family

DPS

Product diameter and material

50 25mm stainless steel

Electrical connection

0 None (flying leads)

3 Polyurethane cable (see note 1 and note 2)

Electronics option

D Digital I2C bus

Compensated temperature range

TC -40°C to +85°C (-40°C to +185°F)

Accuracy

A3 Premium

Calibration

CC Full thermal

Hazardous area certification

H0 None

H1 IECEx/ATEX intrinsically safe 'ia' group IIC

H6 FM (C & US) intrinsically safe 'ia' group IIC

HS IECEx/ATEX/FM (C & US) intrinsically safe 'ia' groups IIC [H1 + H6]

JA INMETRO intrinsically safe 'ia' group IIC

Pressure connector

PA G1/4 female

PB G1/4 male flat

PE 1/4 NPT female

PF 1/4 NPT male

PG 1/8 NPT male

PZ M10 x 1.0 80° int cone

DPS - 50 - 3 - D - TC - A3 - CC - HI - PF (Example part number)

Approval codes and electrical connectors

Approval code	Electrical connector code	
	0	3
H0	Y	Y
H1	Y	Y
H6	N	Y
HS	N	Y
JA	Y	Y

Ordering notes

Note 1: Cable length 3 m

Note 2: CE marked option

Typical order example

DPS503D-TC-A3-CC-HI-PF 20 bar gauge

Mechanical drawings

Internal version

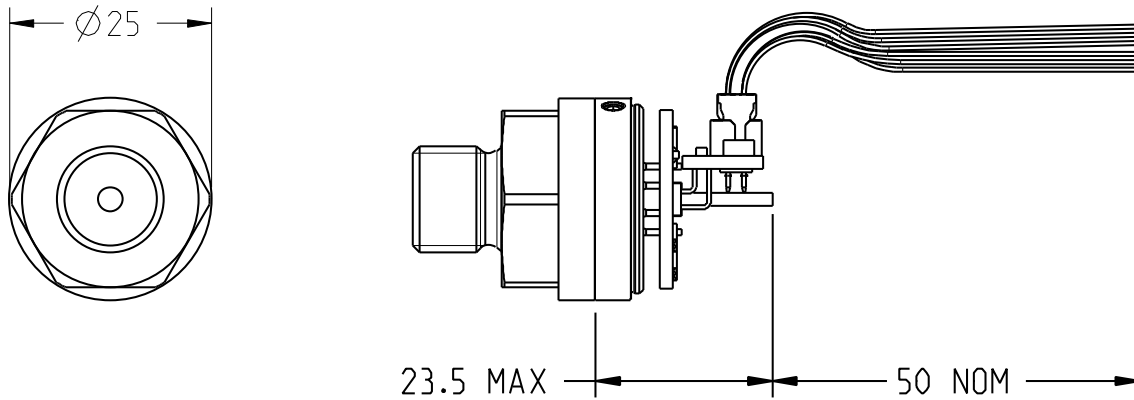

GAUGE SENSOR WITH PB PRESSURE CONNECTOR SHOWN

External version

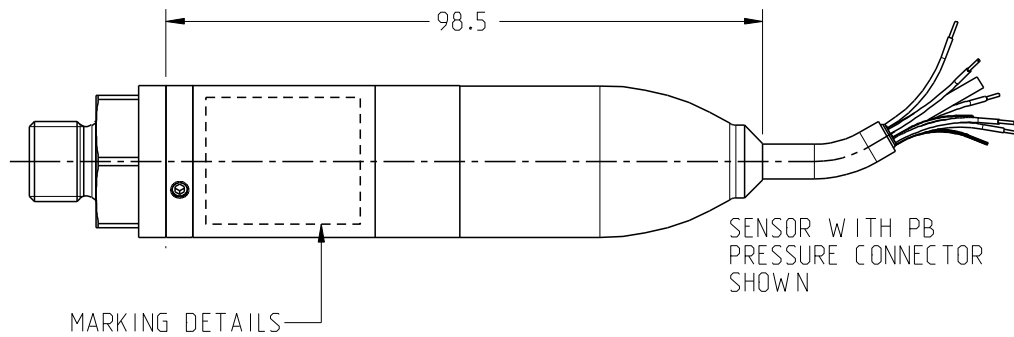

Note: All dimensions in millimeters.