

PV624

Hybrid Pressure Station Instruction Manual



Contents

1.	Overview	1
1.1	Introduction	1
1.2	Other Module Options	2
1.3	Summary of Functions	3
1.4	Quick Reference Data	4
1.5	Equipment in the Box	4
1.6	Safety	4
1.6.1	General Warnings	5
1.6.2	Pressure Warnings	5
1.6.3	Electrical Warnings	5
1.6.4	Software Configuration and Security	6
1.7	Over-voltage Categories	6
1.8	Associated Documents	7
2.	Instrument Parts	9
2.1	Introduction	9
2.2	PV624 Parts	9
2.2.1	Pressure Release Valve and Barometric Port	10
2.2.2	Test Port and Adapter	10
2.2.3	Pump (Pressure/Vacuum)	11
2.2.4	Bluetooth Button	11
2.2.5	Power Button	11
2.2.6	Battery	11
2.2.7	Bluetooth LED	12
2.2.8	Status LED	12
2.2.9	Battery Level Indicator	13
3.	Pneumatic Pressure Operation	15
3.1	Introduction	15
3.2	Release the Pressure	15
3.3	Attach/Remove the Device Under Test	15
3.3.1	Use of Blanking Plug	16
3.3.2	Attach an Instrument Dirt (and Moisture) Trap to the Test Port	16
3.3.3	Attach Device Under Test	16
3.3.4	Remove Device Under Test	17
3.3.5	To Attach the Differential Connection Sensor Kit	17
3.4	Assembly Instructions	19
3.5	Pressure or Vacuum Operation	20
4.	Pressure Calibrator Operation (DPI620G)	23
4.1	Introduction	23
4.2	Parts and Assembly	23
4.2.1	DPI620G Calibrator Parts	23
4.2.2	PM620 Series - Parts	24
4.3	Basic Channel Settings	24
4.3.1	Overview	24
4.3.2	DPI620G Calibrator: Set the Pressure Units	25
4.3.3	DPI620G Calibrator: Process	25

4.3.4	DPI620G Calibrator: Step Mode (Nudge)	26
4.3.5	DPI620G Calibrator: Step Mode (Percent Step)	26
4.3.6	DPI620G Calibrator: Step Mode (Defined Step)	27
4.3.7	DPI620G Calibrator: Step Mode (Point Step)	28
4.3.8	DPI620G Calibrator: Set the PM620/PM620T Module to Zero	29
4.3.9	DPI620G Calibrator: Set the Pressure Type	30
4.3.10	DPI620G Calibrator: Resolution	31
4.4	Utility (Channel Settings)	31
4.4.1	DPI620G Calibrator: Set the Pressure Function	32
4.4.2	DPI620G Calibrator: Set the Pressure Units	33
4.4.3	DPI620G Calibrator: Set Up a Leak Test	33
4.4.4	DPI620G Calibrator: Set Max/Min/Mean Test	35
4.4.5	Example Procedure: Relief Valve Test	35
4.4.6	DPI620G Calibrator: Set Up a Switch Test	36
4.4.7	Example Procedure: Switch Test	36
4.4.8	Low Pressure Sensors	39
4.5	Settings Menu	41
4.5.1	Overview of Settings Menu	41
4.5.2	DPI620G Calibrator: View the Base Battery Status	42
4.5.3	DPI620G Calibrator: View the Base Status and Barometer Status	42
4.5.4	DPI620G Calibrator: Connect PV624 via Bluetooth	43
4.5.5	DPI620G Calibrator: Adjust the Barometer Calibration Date and Interval	44
4.5.6	Example Procedure: Internal Barometer Calibration	45
5.	Help Menu	49
5.1	Overview	49
6.	Maintenance Procedures	51
6.1	Introduction	51
6.2	Service and Repair	51
6.3	Visual Inspection	51
6.4	Clean the Unit	51
6.5	Leak Test	51
6.5.1	Preparation	51
6.5.2	Procedure	52
6.6	Replacement of Battery	52
6.7	Spares	53
6.8	Instrument Return	53
6.8.1	Returned Goods Procedure	53
6.8.2	Instrument Disposal	53
6.9	Firmware Upgrade	53
7.	Test Procedures	55
7.1	Overview	55
7.2	Downloaded Procedures	55
7.3	Calibration Wizard	55
8.	Error Messages	57
8.1	PV624 Error Codes	57

9.	Specification	59
9.1	PV624 Pressure Station	59
9.1.1	PV624 Pressure Data	60
9.2	PM620/PM620T Modules	60
9.2.1	Pressure Data (PM620/PM620T Modules)	61
9.3	PM620LP Module	61
9.3.1	Pressure Data (PM620LP Module)	61
Appendix A.	COMPLIANCE STATEMENTS	63
A.1	FCC (USA)	63
A.1.1	Federal Communication Commission Interference Statement	63
A.1.2	FCC Radiation Exposure Statement	63
A.2	CANADA	63
A.2.1	ISED Canada Statement	63
A.2.2	Radiation Exposure Statement	64
A.2.3	Déclaration d'exposition aux radiations	64

1. Overview



INFORMATION Read this manual carefully before use. Keep for future reference.

This manual gives operation procedures and safety information for the PV624 Pressure Station. It is the responsibility of the user to make sure that only approved personnel can operate and do maintenance on the equipment.

Note: Before you operate the equipment, read and obey all warnings and cautions given in the Quick Start and Safety Manual for this instrument.

1.1 Introduction



Figure 1-1: PV624

The PV624 Hybrid Pressure Station is a portable pressure calibrator with a manual pressure generation capability. A pump and automatic fine adjustment of pressure, operate together to control pressures at set values. When attached to the DPI620G instrument with its Graphical User Interface, together with 4-20 mA supply and voltage measurement, the PV624 can calibrate pressure sensors and transmitters.

The PV624 uses the external PM620 series pressure modules, together with an internal Barometer, to make accurate pressure measurements. The DPI620G has a smart and simple User Interface. This makes it easy for a technician, service or maintenance engineer to operate it.

The PV624/DPI620G assembly when put together, is a practical and robust device that gives accurate measurements. It is battery-powered and uses a highly reliable pneumatic assembly for continuous and accurate performance for field calibration, even in harsh environmental conditions.

HART® communications, Foundation Fieldbus and Profibus communication protocols are available as options. Bluetooth is also available as an optional communication method.

This manual tells how to use the specific functions made available when a PV624 Pressure Station attaches to a DPI620G Calibrator. Refer to the DPI620G instruction manual (K0541) for how to use its user interface and functions.

1.2 Other Module Options



Figure 1-2: PV624+DPI620G = Pressure Calibrator

The PV624 is part of a group of hand-held modules that give a wide range of calibrator functions.

Pressure Calibrator - Attach the DPI620G Calibrator and a PM620 series module to the PV624 to make a fully-integrated pressure calibrator instrument.



Figure 1-3: DPI620G

Advanced Modular Calibrator DPI620G - This is a battery-powered instrument for electrical measure and source operations. It also supplies the power and user interface functions for all the add-on modules. You can use the touchscreen to show up to six different parameters.



Figure 1-4: PM620/PM620T/PM620LP

Pressure Modules PM620/PM620T/PM620LP - These modules attach to the PV624 to give the DPI620G calibrator the necessary pressure measurement functionality. They are fully interchangeable “plug and play” modules, with no initial set-up or user calibration. See later in this document for more details.

1.3 Summary of Functions

These tables give a summary of the available functions with the PV624 pressure station.

Table 1-1: PV624 Only



Function	
	Pressure from vacuum -0.9 barg to 20 barg (-12.328 to 300 psig)
	Internal selector valve to change the pump operation from pressure generator to vacuum generator
	Vent valve to control the release of pressure
	"Quickfit" pressure adapters for the device under test
	Pressure connection for PM620 series modules (2.5 mbar differential to 20 barg)
	Internal automatic fine adjustments to give accurate control of pressure conditions
	Latch mechanism to attach the DPI620G calibrator to make a fully integrated pressure calibrator instrument

Table 1-2: PV624+DPI620G+PM620 Series Modules

Function	
	Automatic control of pressure to +/-55 mbar into 20 mL volume (when used with PM620 of less than 700 mbar or a PM620LP)
	Measure pressure/Leak test
	Documenting software
	4Sight2 integration
	Barometer (Pseudo modes)
	Bluetooth operation

1.4 Quick Reference Data

PV624 Pneumatic Pressure Station

-0.9 barg to 20 barg (-12.328 to 300 psig)

Recommended pressure modules

PM620 series: PM620, PM620T or PM620LP

2.5 mbar diff to 20 barg (10.15 to 300 psig) full scale



CAUTION To prevent damage to the PM620 modules, only use them within the specified pressure limit on the label.

1.5 Equipment in the Box

Make sure these items are with the PV624 when delivered:

1. DC Power Supply (IO610E-PSU)
2. Lithium-Ion Battery pack (IO624 -BATTERY)
3. G1/8 BSP Swivel Adapter (184-203)
4. 1/8 NPT Swivel Adapter (184-226)
5. Blanking Plug (111M7272-1)
6. (IDT) Instrument Dirt Trap (IO620-IDT621-NEW)
7. 2 m USB Cable (IO610E-USB-CABLE)
8. PV624 Quick Start and Safety Manual (170M2459).

1.6 Safety

Before use of the instrument, make sure to read and understand all the related information. This includes: the applicable local safety procedures, this publication, and the instructions for the accessories/options/equipment that are to be used with it.

1.6.1 General Warnings



WARNING Do not ignore the specified limits for the instrument or to use the instrument when it is not in its normal condition. Use the applicable protection and obey all safety precautions.

To avoid risk of an explosion, do not use the instrument in locations with explosive gas, vapor or dust.

1.6.2 Pressure Warnings



WARNING Always wear applicable eye protection when pressurized parts are touched.

It is dangerous to attach an external source of pressure to a PV624. Use only the internal mechanisms to set and control the pressure in the pressure station.

Pressurized gases are dangerous. Safely release all the pressure before connection or disconnection of pressure equipment.

To prevent a dangerous release of pressure: make sure that all the related pipes, hoses and equipment have the correct pressure rating, and are safe to use and are correctly attached. Isolate and bleed the system before disconnection of a pressure connection.

Note: The pressure station does not allow internal overpressure (it will automatically release pressure). It does this to protect the internal pressure sensor and pump mechanism from damage.

Note: Maximum Working Pressure (MWP) is given by the label on the bottom of the PV624.

1.6.3 Electrical Warnings

If the DPI620G Calibrator is attached to the PV624, these warnings are applicable:



RISK OF ELECTRIC SHOCK To prevent electrical shocks or damage to the DPI620G calibrator, do not connect more than 30 V between the terminals, or between the terminals and the ground (earth). Connections must be compatible with the terminal input/output parameters. See “Over-voltage Categories” on page 6. for more information.



CAUTION To prevent damage to the instrument, do not let dirt get into the pressure mechanism. Before attachment of equipment, make sure connections are clean.

To prevent damage to the instrument, hold the body of the pressure station or use the carry strap (or specified accessories) when it is moved.

To prevent damage to the PM620/PM620T module, only use the module within the specified pressure limit on the label.



WARNING External circuits must have applicable insulation to the mains.

This instrument uses a Lithium-Ion (Li-Ion) battery pack. To prevent an explosion or fire, do not short circuit, do not disassemble, and keep safe from damage.

To prevent an explosion or fire, only use the Druck specified battery (IO624-BATTERY) and power supply (IO610E-PSU) rated for this instrument.

To prevent battery leakage/damage or excess heat generation, only use the mains power supply in the ambient temperature range 0 to 45°C (32 to 113°F). The power supply input range is 100 - 240 VAC, 50 to 60 Hz, 300 mA, installation category CAT II.

Long exposure to temperature extremes will reduce battery lifetime. For maximum lifetime, avoid long periods where the battery is exposed to temperatures outside the range -20°C to +40°C. The recommended storage temperature range is -20°C to 25°C.

To make sure the display shows the correct data, disconnect the test leads before the power is set to ON or for a change to another measure or source function.

Note: Before an operation or procedure given by this publication is started, the user must make sure that they have the necessary skills (if necessary, with qualifications from an approved training establishment). Follow good engineering procedures at all times.

1.6.4 Software Configuration and Security

Before use, make sure the relevant instrument settings are as expected. Other personnel that have access to the instrument, can have made unknown changes. Visually inspect the instrument for this type of change, before measurements are taken and calibrations done with the instrument.

1.7 Over-voltage Categories

The following summary of installation and measurement over-voltage categories is taken from the IEC61010-1 standard. Each over-voltage category identifies how dangerous an over-voltage transient can be.

Table 1-3: Over-voltage Categories

Category	Description
CAT I	This is the minimum dangerous over-voltage transient. CAT I equipment must not be directly connected to the mains power. An example of CAT I equipment is a process loop powered device.
CAT II	This is for single phase electrical installation. Examples are appliances and portable tools.

1.8 Associated Documents

This table lists the Druck documents referenced in this manual:

Publication	Title
K0542	DPI620G Quick Start and Safety Manual
K0541	DPI620G Instruction Manual
170M2459	PV624 Quick Start and Safety Manual

2. Instrument Parts

2.1 Introduction

This chapter identifies of the different parts of PV624 instrument.

2.2 PV624 Parts

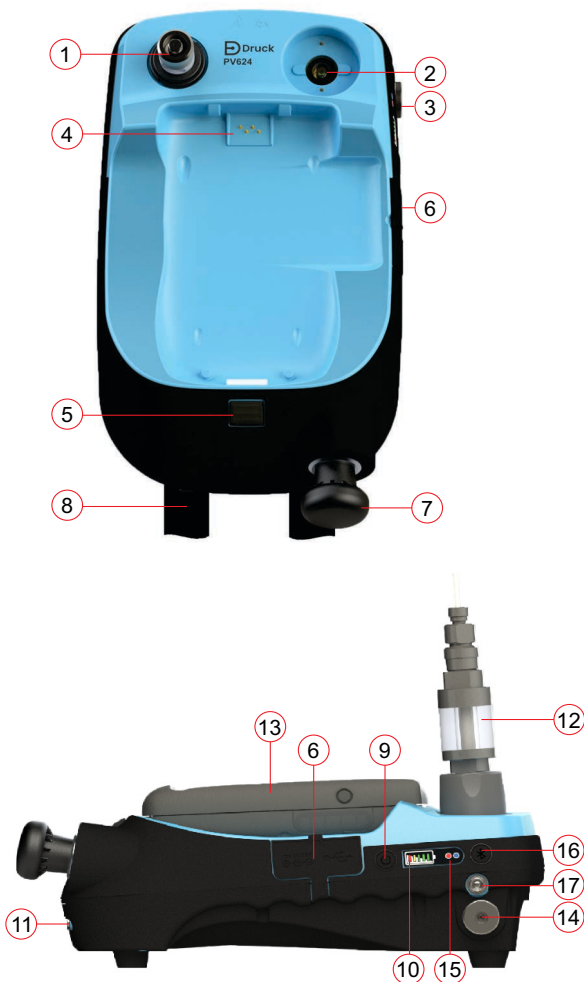

Description	
1	Test port: Pressure connection (G1/8 or 1/8NPT) to attach the device under test; see Section 2.2.2.
2	Pressure and electrical connections for a PM620 series module. Seal the pressure connection with a Blanking Plug (111M7272-1) or a PM620 series module that has the correct pressure rating.
3	Pressure Quick Release Valve (ON/OFF); see Section 2.2.1
4	Molded compartment for the DPI620G calibrator with electrical connections and a mechanism to hold it in position.
5	Push-button mechanism to release the DPI620G calibrator.
6	Protective cover for power port and USB port.
7	Hand Pump (see Section 2.2.3 on page 11).
8	Carrying strap with a carry handle and a shoulder strap.
9	Power ON/OFF button (see Section 2.2.5 on page 11).
10	Battery level indicator (One bar equals 20% charge): see Section 2.2.9
11	Screws for removable battery cover.
12	Dirt Trap and connecting hose.
13	DPI620G instrument.
14	Barometric port (see Section 2.2.1 on page 10).
15	Indicator lights: Status (see Section 2.2.8 on page 12) and Bluetooth (see Section 2.2.4).
16	Bluetooth button (Section 2.2.4 on page 11).
17	Strap Clip fastener for Carrying Strap.

Chapter 2. Instrument Parts

2.2.1 Pressure Release Valve and Barometric Port



Figure 2-1: Pressure Release Valve

The Pressure Release Valve is on the bottom right of the instrument. To release pressure, slowly turn the valve knob counterclockwise one full rotation. Make sure the system is sealed before pressure generation: fully turn the valve in the clockwise direction to close.

Note: The use of the Pressure Release Valve is only necessary for the manual pressure operation - in normal operation the unit will automatically vent. Move the unit with the Pressure Release Valve open, to make sure that no pressure is trapped.



Figure 2-2: Barometer Port

The Barometer Port is inside the Pressure Release Valve. This port is a static pressure inlet to the internal barometric pressure sensor.

The Barometric Port is accessible by the use of a G1/8 adapter and is in the center of the Pressure Relief Valve knob. Calibration of the barometer is done through this port.

2.2.2 Test Port and Adapter



Figure 2-3: Test Port and Adapter

This image shows the PV624 “Quickfit” connector with an attached “optional (included)” G1/8 pressure adapter. This pressure adapter holds the device under test or a hose to the device.

The Test Port is at the top left corner of the instrument. Pressure can be supplied to pressure devices that connect, either directly, or by the use of compatible hose fittings.

2.2.3 Pump (Pressure/Vacuum)



Figure 2-4: Pump Handle

When you have set the operation mode to pressure or vacuum, seal the system (Section 3.5). Move the pump handle forwards and backwards to pressurize the instrument or make a vacuum.

2.2.4 Bluetooth Button



Figure 2-5: Bluetooth Button

The Bluetooth button is next to the Battery Charge Indicator.

On a PV624 that has Bluetooth installed, you can disconnect the PV624 and DPI620G from each other and then push the button to select the Bluetooth mode. A wireless communication channel then becomes available.

In the Bluetooth mode you can use the DPI620G and PV624 as if they are one device, when they are less than 5m from each other.

2.2.5 Power Button

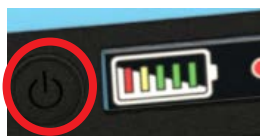

Figure 2-6: Power Button

The Power button is on the right side of the instrument, next to the battery indicator. Push the button until the PV624 energizes (power on.)

2.2.6 Battery



Figure 2-7: Battery

The instrument has a chargeable Li-ion battery that is easy to remove and replace. Read the 170M2459 Quick Start and Safety manual for how to charge the battery.

Chapter 2. Instrument Parts

2.2.7 Bluetooth LED

The Bluetooth LED shows the status of pairing to the DPI620G. Refer to image in Section 2.2.9. It has two different indications; Blue and Red which Table 2-1 describes.

The blue LED on the PV624 blinks fast when a Bluetooth module is available and PV624 begins pairing.

Table 2-1: Bluetooth Indication LEDs

Bluetooth available in PV624	Button label	Press time	LED color	LED state
Yes	Bluetooth pairing button	Between 1 and 4 seconds	Blue	Rapid blinking while connecting and continuously ON after successful pair
No	Bluetooth pairing button	Between 1 and 4 seconds	Red	Solid RED to show that Bluetooth is not available in PV624

2.2.8 Status LED



Figure 2-8: Status LED

The status LED shows the different operational modes of the PV624. Refer to image in Section 2.2.9.

It has three different indications as described in this table:

Table 2-2: Status Indication LEDs

Indication	LED Color	Remarks
Status - Power ON	Green	Solid Green: When the device is powered up, idle and vented.
Status - Unit Pressurized	Orange	When the calibration cycle is active and the device is pressurized.
Status - Error	Red	Error/Faults

2.2.9 Battery Level Indicator

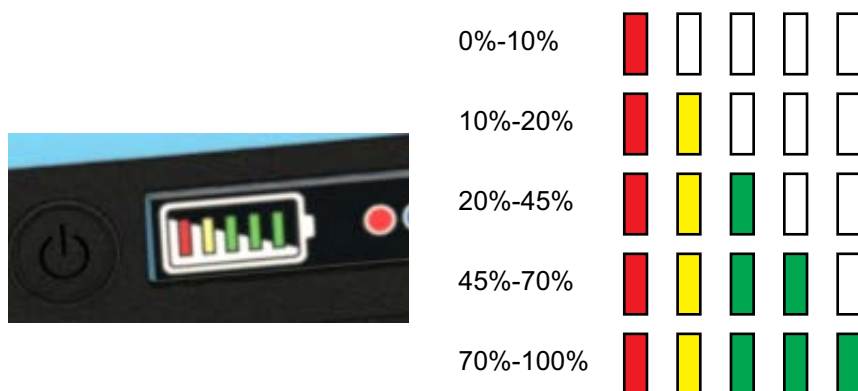

Figure 2-9: Battery Level Indicator

A battery level indicator is on the same side of the PV624 as the charging socket. Each of the five segments of the indicator represents a percentage of the total battery capacity.

The indicator shows battery power for 5 seconds after the PV624 power button is pushed. It is always shown when charging. When the battery charge is less than 10%, the indicator blinks rapidly at 200 ms every 4 seconds.

Chapter 2. Instrument Parts

3. Pneumatic Pressure Operation

3.1 Introduction



Figure 3-1: PV624+DPI620G

This chapter gives examples of how to connect and use the PV624 pressure station with the DPI620G, to make the necessary pressure or vacuum conditions.

Before you start:

- Read and understand the “Safety” section.
- Make sure that the instrument has no damage, and that there are no missing parts.

Note: Use only original parts supplied by the manufacturer.

3.2 Release the Pressure



Figure 3-2: Pressure Release Valve

The PV624 automatically vents the system when you push the Power button to energize (power on) or de-energize (power off) the device.

To release the pressure manually, turn the Pressure Release Valve one complete revolution counterclockwise to release the pressure to atmosphere.

To release the pressure automatically, select the vent  button on the pressure measurement screen of the DPI620G. Refer to screen in step 6 of Section 3.5.

3.3 Attach/Remove the Device Under Test



Figure 3-3: Adapter



WARNING Pressurized gases are dangerous. Before connection or disconnection of pressure equipment, safely release all the pressure.

Chapter 3. Pneumatic Pressure Operation



CAUTION To prevent damage to the instrument, do not let dirt get into the pressure mechanism. Before attachment of equipment, make sure it is clean.

The Test Port is equipped with a “Quickfit” adapter. This pressure adapter holds the device under test or a hose to the device.

You can use a flexible hose with the PV624 to connect to other equipment. Before use always visually check the hose for faults, such as splits or cuts.

3.3.1 Use of Blanking Plug



Figure 3-4: Blanking Plug

A Blanking Plug seals the Test Port and stops access of foreign matter into the port. It is good practice to attach the Blanking Plug when the Test Port is not in use.

To remove the Blanking Plug, hold the adapter firmly in one hand and turn the locking collar in a clockwise direction.

3.3.2 Attach an Instrument Dirt (and Moisture) Trap to the Test Port



To attach the Instrument Dirt (and Moisture) Trap (IDT) to the Test Port:

1. First remove the Blanking Plug if it is in the test socket: turn the locking collar clockwise to release the plug.
2. Put the IDT into the socket. Hold in position while you turn the locking collar fully counterclockwise until it is hand tight.

3.3.3 Attach Device Under Test



To attach the device under test to the Test Port or dirt trap:

1. Put the dirt trap into the thread of the locking collar and hold in position. Turn the locking collar fully counterclockwise until it is hand tight.
2. Make sure that the device under test is fitted with a male G3/8 Quickfit adapter thread or use a suitable adapter rated to 20 bar.

If in doubt, please contact our service and support shown on the rear of this document.

3.3.4 Remove Device Under Test

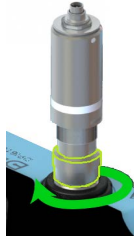

To remove a device, release the pressure first (Section 3.2):

1. To remove the device under test, hold it firmly while you turn the locking collar fully clockwise.
2. Attach the Blanking Plug to seal and protect the socket if the instrument will not be used immediately.

3.3.5 To Attach the Differential Connection Sensor Kit

The PM620LP differential connection sensor kit contains parts to allow a differential connection from the PV624 and PM620LP sensor to the device under test.

Use the following images and steps to setup a differential connection.

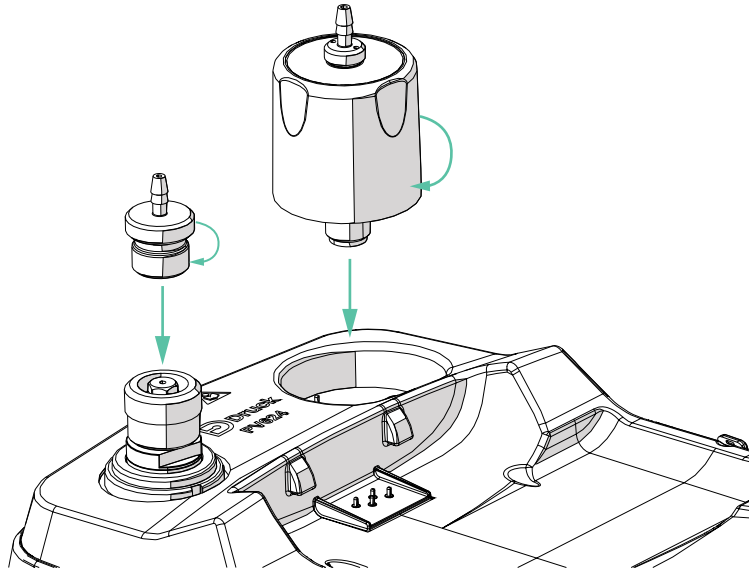

1. Attach the PM620LP sensor to the PV624.
2. Attach the barbed swivel adapter to the PV624 test port.

Chapter 3. Pneumatic Pressure Operation

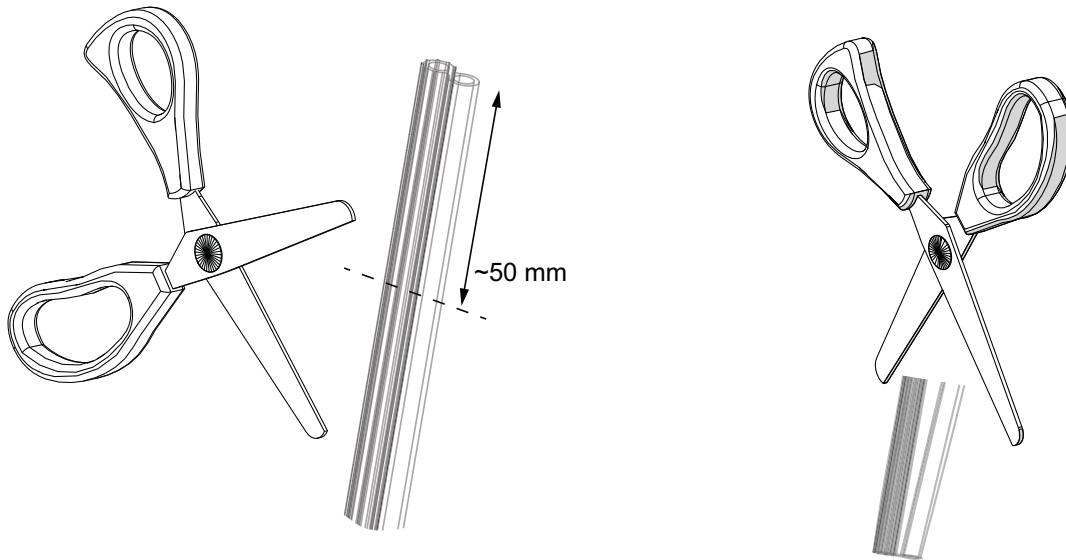

3. Cut off two small sections (~50 mm) of dual hose (included in the kit).
4. Separate the small sections of dual hose by cutting down the center.

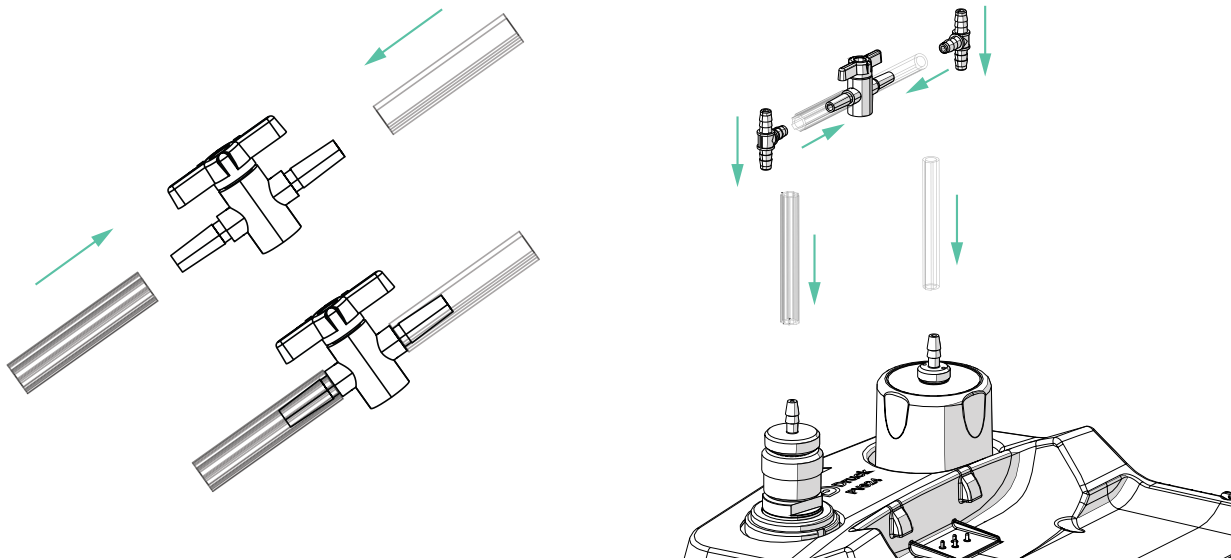

5. Open the zeroing valve and attach a section of hose into each end of the zeroing valve.
6. Attach the remaining sections of hose to the barbed swivel adapter and the barb on the PM620LP sensor.
7. Attach a tee (included in the kit) to each end of the hose of the barbed connector and PM620LP.
8. Attach the ends of the zero valve to each tee.

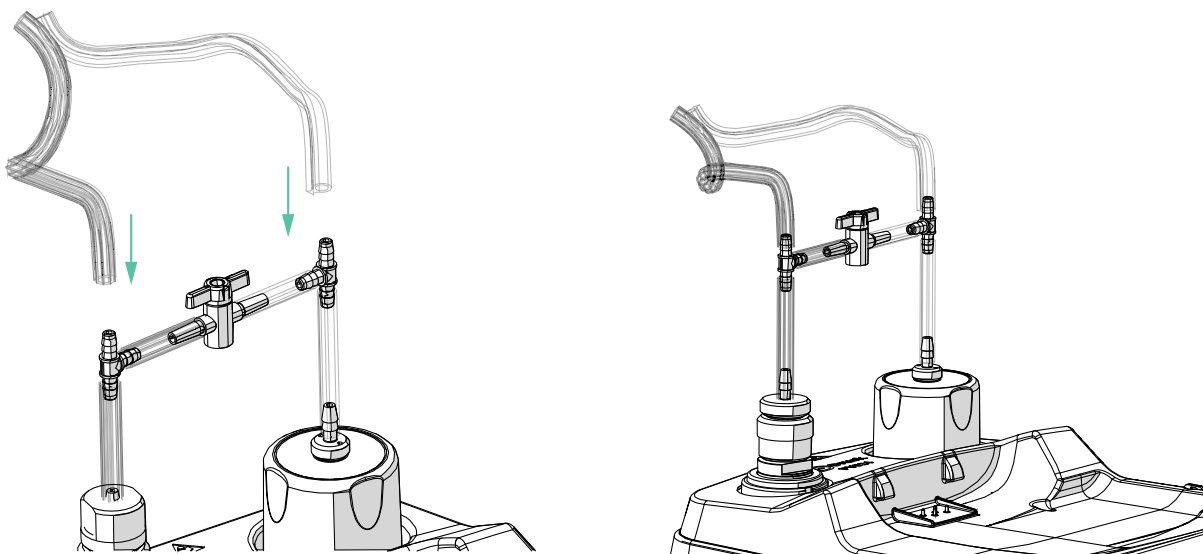

9. Separate approximately 100 mm of dual hose by cutting down the center.
10. Attach the separated ends to each tee.

3.4 Assembly Instructions



1. Energize (power on) both devices. To do this, push the power button on the DPI620G until the device energizes. Do this again on the PV624.



2. Lower the DPI620G calibrator into its compartment in the PV624. Push on the bottom end of the calibrator until it latches in position.



Chapter 3. Pneumatic Pressure Operation

3. The DPI620G screen shows the message 'Base: Connected' when the device fully connects to the PV624, and communication signals occur. The DPI620G screen shows the Base Battery icon when the PV624 battery supplies power.

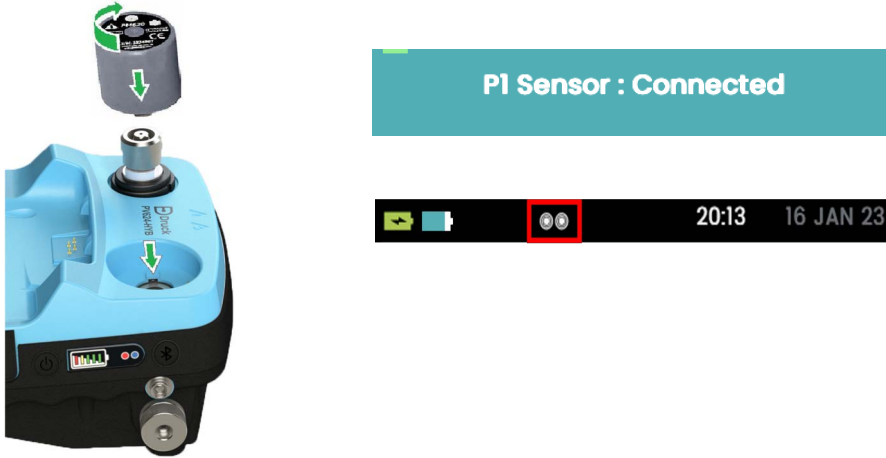

4. Attach a PM620 series module with the range and type necessary for your tests. To do this, put the module into the socket and hand turn the module clockwise to tighten into position. The screen will show 'P1 Sensor: Connected' and a sensor icon when the sensor makes a connection. The screen will show the P1 pressure channel and its pressure values. The assembly is now ready for use.

3.5 Pressure or Vacuum Operation

After attaching a device to the Test Port (Section 3.3) and the DPI620G to the PV624 pressure station, use this procedure to set the necessary pressure or vacuum.

Note: Use this procedure to generate a vacuum.



1. Turn the Pressure Release Valve clockwise (1 turn) to seal the system.

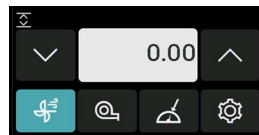

2. Set the control value with the nudge up and down arrows to increase or decrease the pressure.



3. Use the hand pump to pressurize the system. The PV624 controller will then automatically fine tune the pressure to the set value.

When the system reaches the set value, the hand pump disconnects and it will pump to the atmosphere.

Note: When using a PM620LP and a PM620 of less than 700 mbar, the pressure can be automatically applied up to 55 mbar into a 20 mL volume.

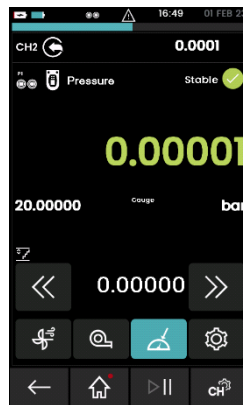

4. The reading will change to green when the pressure is stable.

Chapter 3. Pneumatic Pressure Operation

4. Pressure Calibrator Operation (DPI620G)

4.1 Introduction



Figure 4-1: PV624+DPI620G+PM620

This section gives examples of how to use the pressure station to do pressure calibrations with the DPI620G calibrator and the applicable PM620 series pressure module.

Before you start:

- Read and understand the “Safety” section.
- Do not use an instrument that has damage.

Note: Use only original parts supplied by the manufacturer.

4.2 Parts and Assembly

To make a fully integrated pressure calibrator instrument, use these items:

- PV624 Pressure Station
- DPI620G calibrator. See Section 4.2.1
- An applicable PM620 series module for the pressure station. See Section 4.2.2.

4.2.1 DPI620G Calibrator Parts

Refer to the DPI620G User Manual for more details.

Table 4-1: List of DPI620G Parts



Description	
1	Power button. Push the button and keep the button down until the device fully energizes (power on).
2	Channel 1 (CH1) sockets for electrical measure and source operations.
3	Isolated channel 2 (CH2) sockets for electrical measure and source operations and a 24 V loop power supply (24 V).
4	Rubber pull-down cover for the USB type A connector; USB mini-type B connector and +5 V DC power input socket.
5	Color display with touchscreen. The number of windows you see on the display is set by the number of task selections and external modules you are working with. Select your choice on the display area

Chapter 4. Pressure Calibrator Operation (DPI620G)

4.2.2 PM620 Series - Parts



CAUTION To prevent damage to the PM620 modules, only use them within the specified pressure limit on the label.

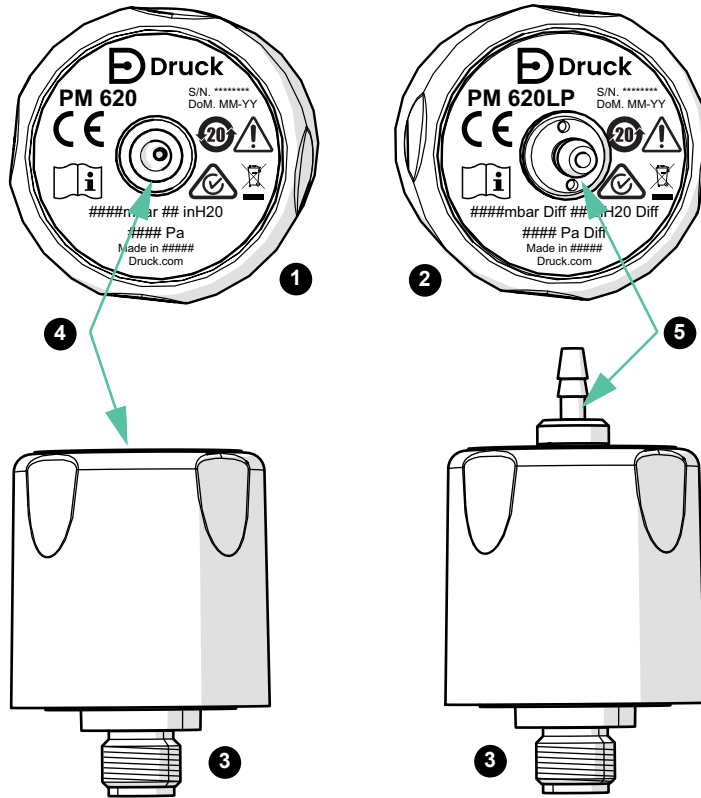

Figure 4-2: PM620 Series Modules

- | | | | |
|---|----------------------------------|---|----------------|
| 1 | PM620/PM620T | 2 | PM620LP |
| 3 | Threaded pressure connection | 4 | Reference Port |
| 5 | Low Pressure Port (PM620LP only) | | |

The PM620 and PM620T pressure modules have a threaded pressure connection, a reference port and a label. Two metal rings surround the threaded pressure connection. These are the electrical connection to the PV624. The PM620LP (low pressure) modules are the same as the PM620 and PM620T except that they are differential sensors, so the threaded connection is the higher pressure port and the barbed top connection is the lower pressure port.

The module labels show:

- Pressure range. For example: 20 bar g (g: gauge; a: absolute) or 2.5 mbar diff (differential).
- Serial number (S/N).
- Manufacturer. Name, address, website.

4.3 Basic Channel Settings

4.3.1 Overview

Note: For more information, refer to the DPI620G manual.

When the PV624 and DPI620G assembly is complete (Section 3.5), use the calibrator to measure the pressure or vacuum in the PV624.

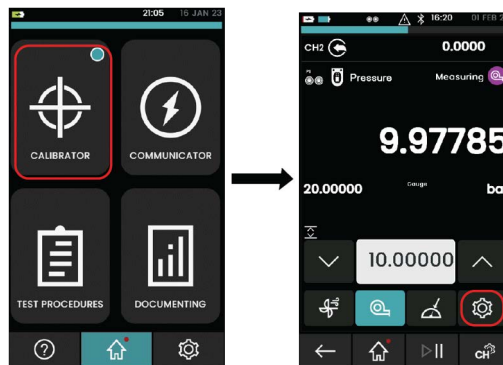

To change and use the pressure channel settings, select the **Calibrator** icon, then select the settings  icon to show the basic channel settings.

4.3.2 DPI620G Calibrator: Set the Pressure Units

This example shows the sequence to set the pressure units. It is a similar procedure for other units, for example **psi** and **MPa**.

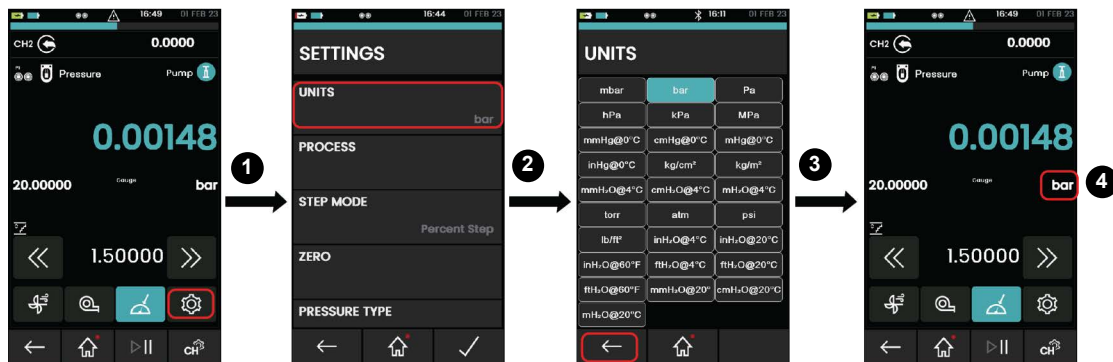

To set pressure units, select **Settings > Units**. Select your units, then select the back button.

4.3.3 DPI620G Calibrator: Process

Process options relate to the measured values for individual channel functions. Options that are available depend on the function and include:

Option	Description
Tare	Sets a temporary value for zero. This makes an adjustment to all subsequent readings on the display.
Alarm	Use this to show when a limit has been exceeded.
Filter	Sets the performance band and time constant for a low pass filter.
Scaling	Scales absolute values.
Flow	When selected, the square root of the measured value is shown.

Chapter 4. Pressure Calibrator Operation (DPI620G)

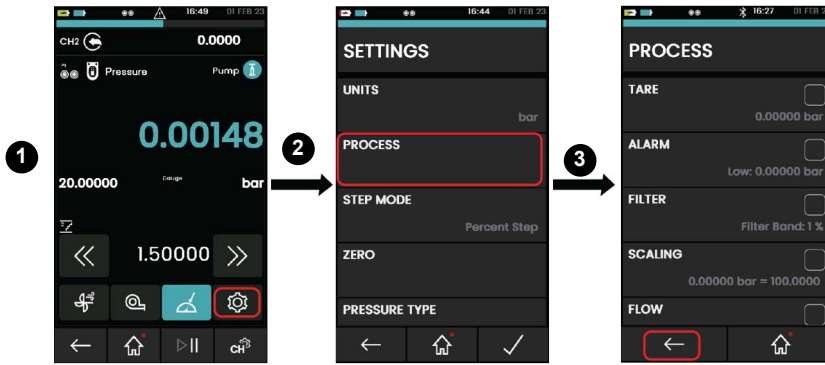

To set the process options, select **Settings > Process**. Choose your option and select the back button.

4.3.4 DPI620G Calibrator: Step Mode (Nudge)

This is the default Step Mode option. This lets the source value be done in increments by a set step value.

This example shows the sequence to set the **Nudge Step Mode**:

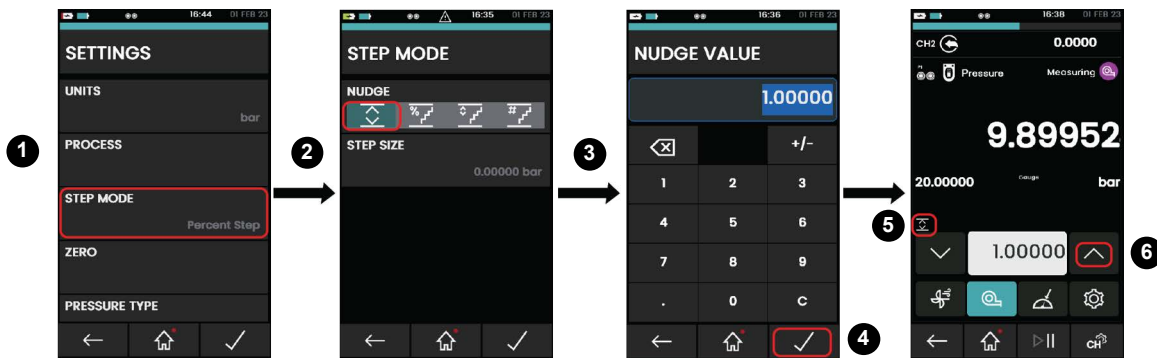

To access the **Settings** menu refer to Section 4.3.1.

1. On the **Settings** menu, select the **Step Mode**.
2. Select the **Nudge** option and then select the **Step Size** icon.
3. On the **Nudge Value** screen, enter the specified value to set the **Step Size**. For example: enter value, 1 bar, to set the Nudge value as a 1 bar step increment.
4. Select the icon three times to show the calibrator screen.
5. The channel screen shows the selected step size icon.
6. Select the up arrow to increase the value to 1 bar, 2 bar or more as an increment to value 1 from the set value.

4.3.5 DPI620G Calibrator: Step Mode (Percent Step)

This mode lets the source value increase in increments, in steps that relate to a set percentage of the span of values. The **Low**, **High** and **Step Size** value can be set.

This example shows the sequence to set the **Percent Step Mode**:

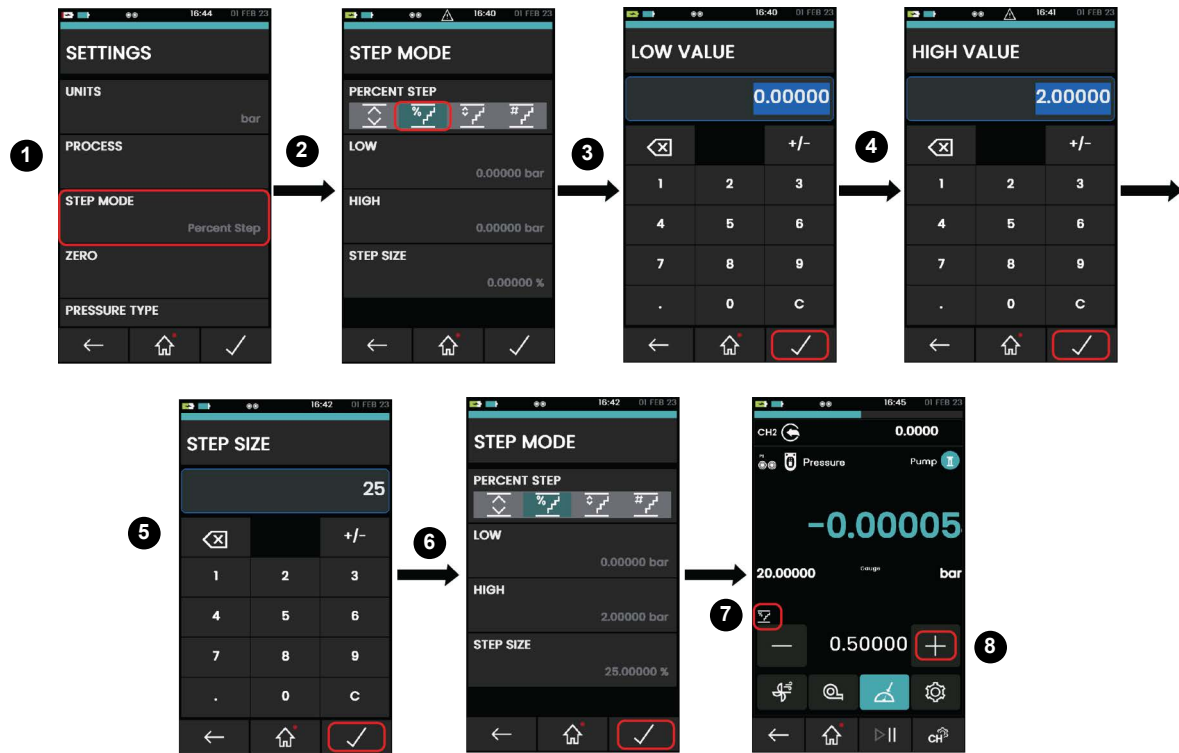

To access the **Settings** menu refer to Section 4.3.1 on page 24.

1. On the **Settings** menu, select the **Step Mode**.
2. Select the **Percent Step** option and then set the **Low**, **High** and **Step Size** values. Example values are given in the procedural steps below
3. On the **Low Value** screen, enter 0 and then select the icon. Now 0 bar is set for the low value.
4. Select **High** and enter 2 and then select the icon. Now 2 bars is set for high.
5. Select **Step Size** and enter 25 and then select the icon. 25% is set for step size.
6. Select the icon three times to show the calibrator screen.
7. The channel screen shows the selected step size icon.
8. Select the **+** icon available next to set point value.

The selected **Low** is 0 bar, **High** is 2 bar and **Step Size** is 25%. If you select the + icon the set point value will increase by 25% from 0 until 2 bars. For example: it starts from 0.5 i.e., 25% of 2 and next value 1 bar, 1.5 bar, 2 bars.

Note: The Set point value will not increase more than 2 bars, because **High** is set at 2 bars.

4.3.6 DPI620G Calibrator: Step Mode (Defined Step)

This mode lets the source value increase in set increments (steps) within the span limits. The **Low**, **High** and **Step Size** value can be set.

Chapter 4. Pressure Calibrator Operation (DPI620G)

This example shows the sequence to set the **Defined Step Mode**:

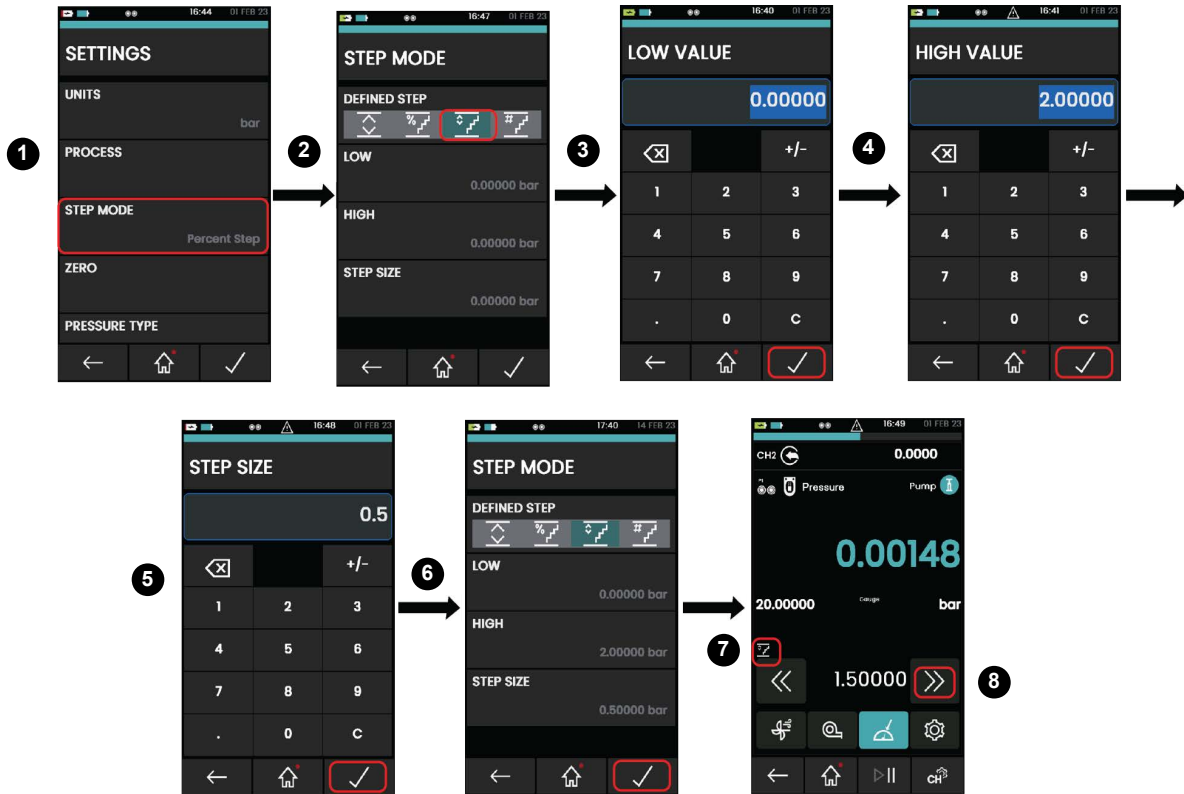

To access the **Settings** menu refer to Section 4.3.1 on page 24.

1. On the **Settings** menu, select the **Step Mode**.
2. Select the **Defined Step** option and then set the **Low**, **High** and **Step Size** values. Example values are given in the procedural steps below.
3. On the **Low Value** screen, enter 0 and then select the icon to set the **High** value to 2.
4. Select **High** and enter 2 and then select the icon. Now 2 bars is set for high.
5. Select **Step Size** and enter 0.5 and then select the icon. 0.5 bar is set for step size.
6. Select the icon three times to show the calibrator screen.
7. The channel screen shows the selected step size icon.
8. Select the >> icon available next to set point value.

The selected **Low** is 0 bar, **High** is 2 bars and **Step Size** is 0.5. When you select the >> icon the set point value increases by six different values. For example: the value starts from -0.5 bar then increases by 0.5 bar for each step, up to 2 bars. This lets you calibrate the system with six different set point values.

Note: The Set point value will not increase more than 2 bars, because **High** is set at 2 bars.

4.3.7 DPI620G Calibrator: Step Mode (Point Step)

This mode makes the source value increase and decrease in a set number of points. When **Direction** is set to **Up** the number of points will increase from **Low** to **High**. When **Direction** is set to **Down**, the number of points will be from the **High** to **Low** value.

This example shows the sequence to set the **Point Step Mode**:

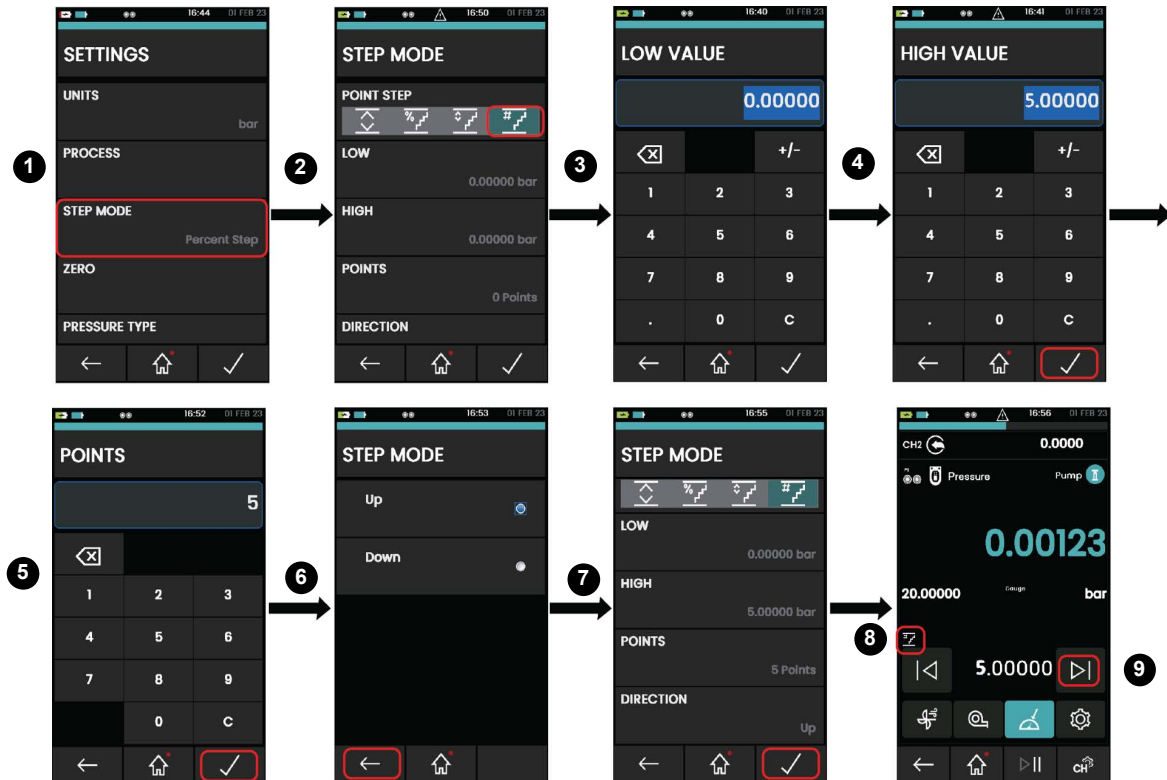

To access the **Settings** menu refer to Section 4.3.1.

1. On the **Settings** menu, select the **Step Mode**.
2. Select the **Point Step** option and then set the **Low**, **High**, **Points** and **Direction** values. Example values are given in the procedural steps below.
3. On the **Low Value** screen, enter 0 and then select the icon: 0 bar is set for the low value.
4. Select **High** and enter 5 and then select the icon to set the **High** value to 5.
5. Select **Points** and enter 5 and then select the icon to set 5 points for **Points**.
6. Select **Direction** and select **Up** for the direction.
7. Select the icon three times to show the calibrator screen.
8. The channel screen shows the selected step size icon.
9. Select the icon to set point value.

The selected **Low** is 0 bar, **High** is 5 bar and **Points** is 5 (the **Point** value can be from 1 to 25.) In this example, when you select the next icon the set point value will increase by 1 bar. This lets calibration of the system be done by the point increments.

The Set point value will not increase more than 5 bars, because **High** is set at 5 bars.

Note: A set point pressure value must be in full units, for example, 1 bar, 2 bar.

4.3.8 DPI620G Calibrator: Set the PM620/PM620T Module to Zero

Use this option to write a new zero pressure value to the PM620/PM620T module in use. This option only affects gauge type modules. See Section 4.4.8 for zeroing a PM620LP module.

It is recommended that all gauge sensors are zeroed at the start of each day before use.

Chapter 4. Pressure Calibrator Operation (DPI620G)

This example shows the sequence to set the **Point Step Mode**:

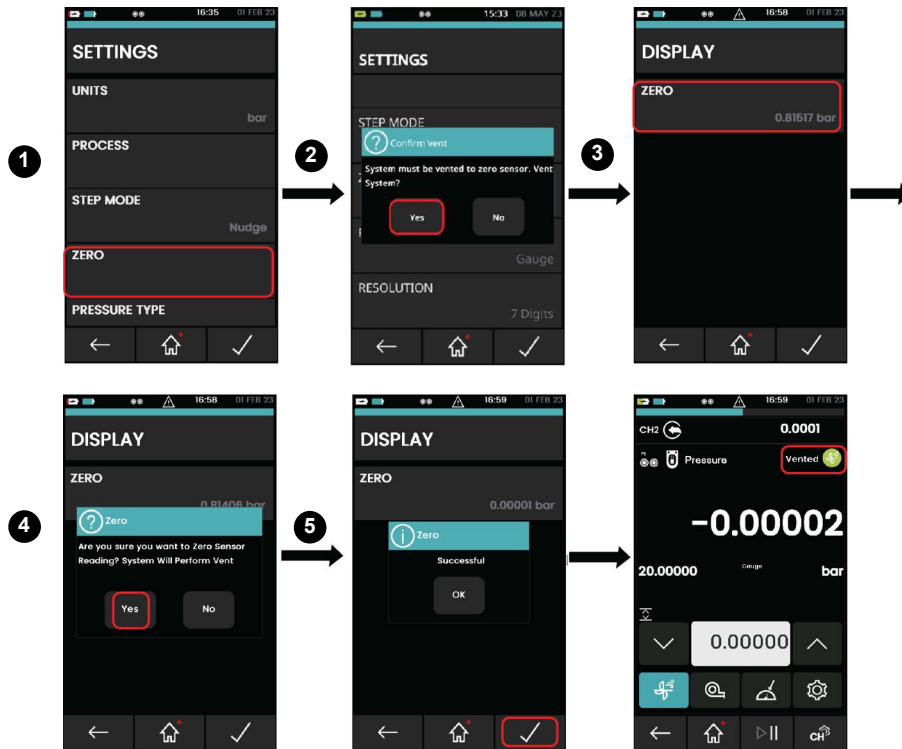

To access the **Settings** menu refer to Section 4.3.1.

1. Select **Zero**.
2. Select **Yes** to release any pressure in the system.
3. Select **Zero** to do the zero action.
4. Select **Yes** to confirm the zero action.
5. The screen will show the message 'Zero Successful'.
6. The calibrator screen will show the zero reading

Note: To make a temporary adjustment for zero, you can use the Tare function: Select **Settings** > **Process** > **Tare** (refer to the DPI620G User Manual).

Note: A Zero Error can occur if the pressure indication measured from the sensor, is more than 1% of the full-scale value when the instrument pressure port is opened to atmosphere.

4.3.9 DPI620G Calibrator: Set the Pressure Type

The PM620 series pressure sensors are of three types:

- Gauge
- Absolute
- Differential

Gauge and Absolute sensors can be set up to use a Pseudo mode. The Pseudo mode combines the original sensor type and barometric reading from the PV624, to show the Pseudo pressure reading (Pseudo-abs/Pseudo-gauge). For reference, the barometric reading is shown in Pseudo mode. From the **Pressure Type** settings, the option is available to show the barometric reading as the primary reading.

Note: Pseudo mode is not available with PM620 sensors <700 mbar or with PM620LP sensors.

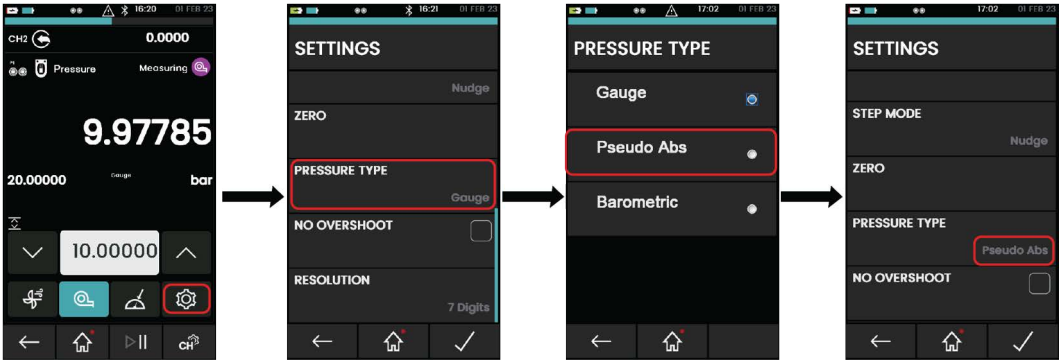

To select the pressure type, select **Settings > Pressure Type**, then select your **Pressure Type** (for example, Pseudo Abs).

4.3.10 DPI620G Calibrator: Resolution

Use this option to change the set point value on the calibrator screen to be seen in the range of 4 to 7 digits.

Note: The resolution is the maximum number of digits available to show a value. The full scale value also affects the value shown. For example, if 20 bar is the full scale value and the resolution is set to 7. A measured value of 10 bar will be shown as 10.00000 (7 digits). If 20 bar is the full scale value and the resolution is set to 5 digits, a measured value of 10 bar will be shown as 10.000 (5 digits). If the full scale value is 20 bar, resolution is 7, a measured value of 1 bar will be shown as 1.00000 (7 digits are available but only 6 digits are necessary to show the value).

This example shows the sequence to set the Resolution:

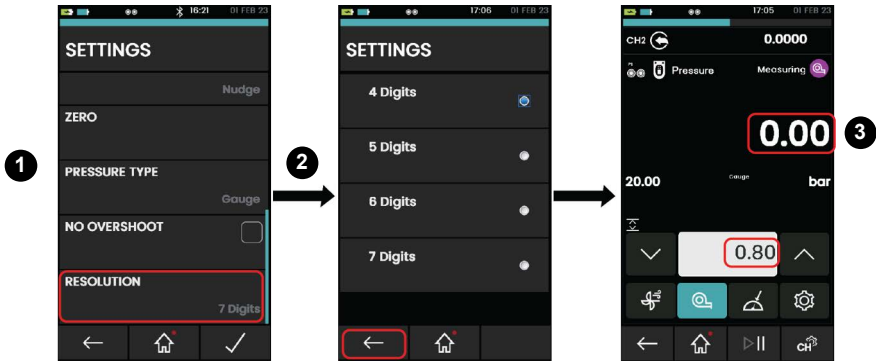

To access the **Settings** menu refer to Section 4.3.1. Select **Settings > Resolution**, then select your option. The screen will show your chosen option.

4.4 Utility (Channel Settings)

The **Tasks Menu**  gives access to these utilities shown below:

Chapter 4. Pressure Calibrator Operation (DPI620G)

4.4.1 DPI620G Calibrator: Set the Pressure Function

This example shows the sequence to set the pressure function. It is a similar procedure for other functions; refer to the DPI620G User Manual.

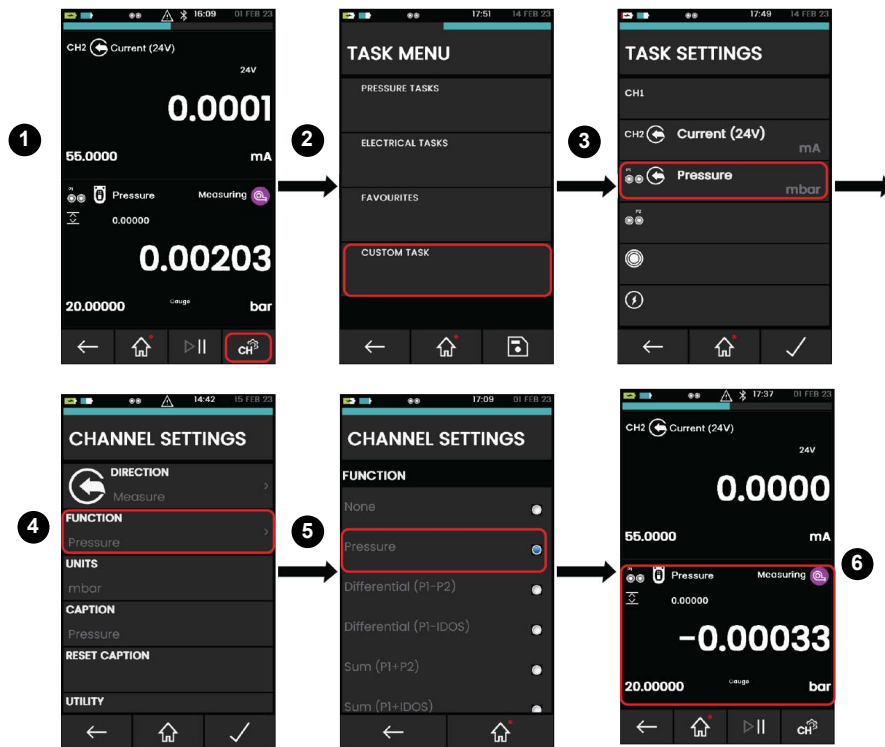

1. Select to open the **Task Menu**.
2. Select **Custom Task** to open the **Task Settings**.
3. Select the **Pressure** channel to open the **Channel Settings**.
4. Select the **Function**.
5. Select your pressure function

4.4.2 DPI620G Calibrator: Set the Pressure Units

This example shows the sequence to set the pressure units.

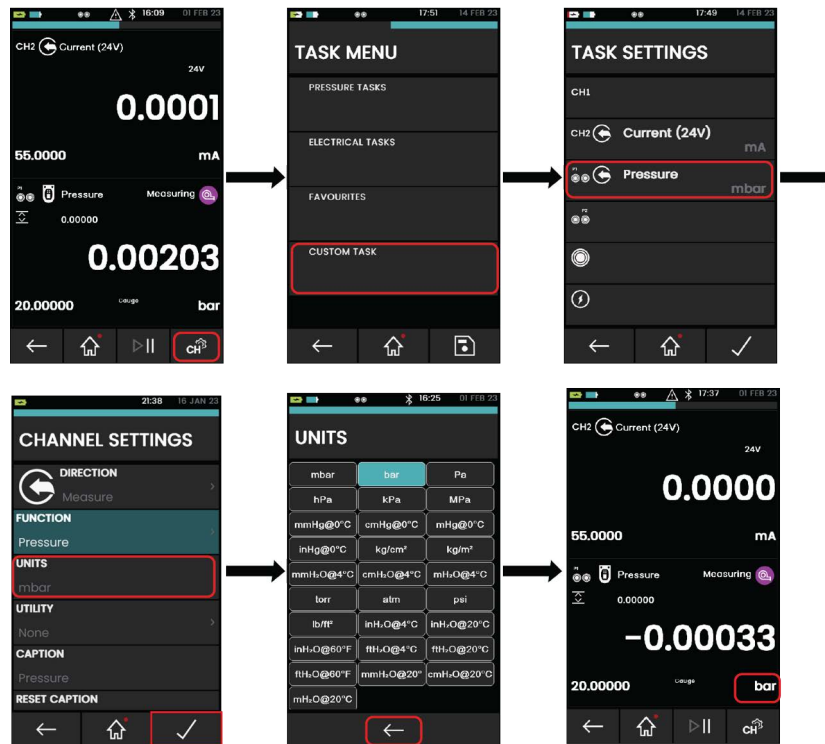

1. Select to open the **Task Menu**.
2. Select **Custom Task**.
3. Select the **Pressure** channel
4. Select **Units**.
5. Select the pressure unit.

4.4.3 DPI620G Calibrator: Set Up a Leak Test

It is recommended a Leak Test be done before the completion of a calibration or operation. This is to be sure the pressurized system and associated components will not leak.

When a Device Under Test (DUT) connects to the PV624 pressure Test Port (either directly or with hoses and auxiliary connections) there can be leaks.

In a Leak Test, you apply pressure (or vacuum) to the system (typically not exceeding 10% of the sensor working pressure) and make a record of pressure changes in this test.

To do a leak test, you must first set the **Utility** to **Leak Test**:

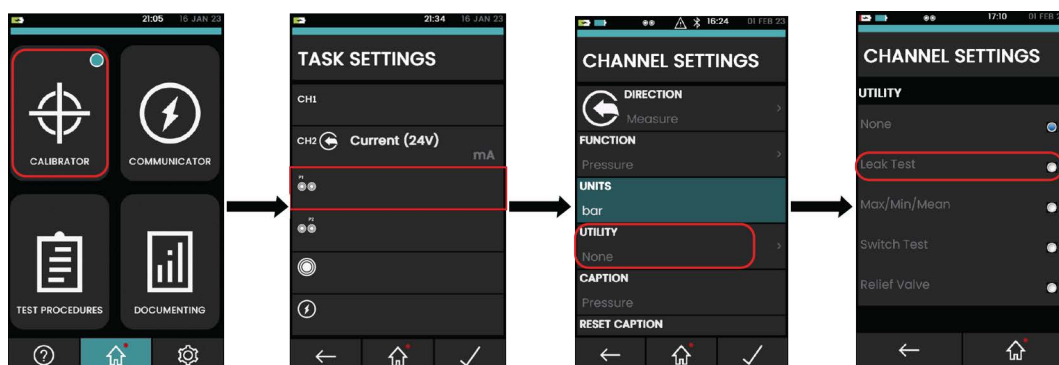

Chapter 4. Pressure Calibrator Operation (DPI620G)

To do this, select **Calibrator > Task Settings > Channel Settings > Utility > Leak Test**.
Now you must set the Leak Test options:

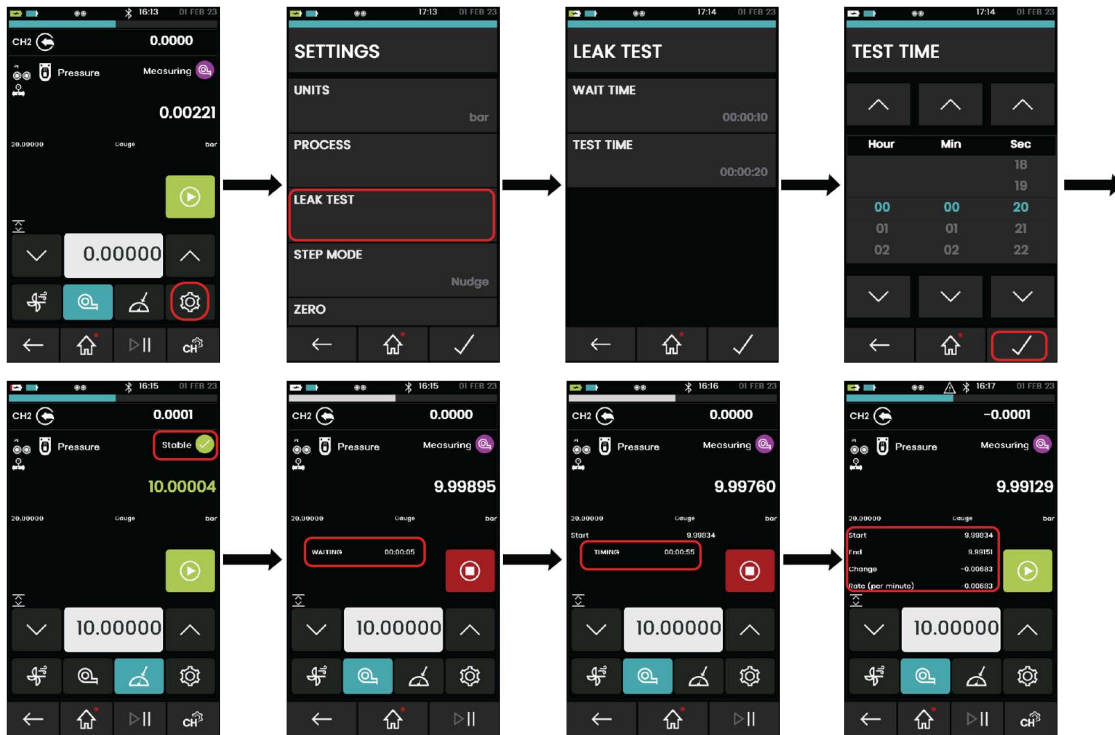

1. Select **Settings**.
2. Select **Leak Test**.
3. Set the Leak Test options:

When you have set the **Utility** to **Leak Test**, you can use these options from the **Channel Settings** (See “Basic Channel Settings” on page 24.):



a. Wait Time

Before you start a Leak test, you must let the pressurized system become stable before the test starts. The time for this is the **Wait Time** on the PV624. The time before the test starts is in hours:minutes:seconds (hh:mm:ss)

b. Test Time

This is the period in which a change in pressure in the PV624 is to be recorded. The period of the leak test is in hours:minutes:seconds (hh:mm:ss)

Note: To set the Leak Test options, you must have a PM620/PM620T module correctly installed (Section 4.3 on page 24).

4. Set the PV624 to a pressure point and make sure pressure is stable. The user must set a control point for the pressure to stabilize. A control point must be set to let a leak test to start.
5. Select the **Play**  icon to start the Leak test. **Start** pressure is recorded when the **Test Time** starts after the **Wait** time.
6. If necessary, select the **Stop**  icon to stop the Leak Test with no results.
7. When the **Test Time** countdown is complete, the **End** pressure value is recorded and the Leak Rate per minute is calculated and shown as the Leak Test result.

4.4.4 DPI620G Calibrator: Set Max/Min/Mean Test

When you select this utility, the calibrator shows real-time minimum, maximum, and average values of the measured signal, and the live measured reading. For more information refer to the DPI620G user manual.

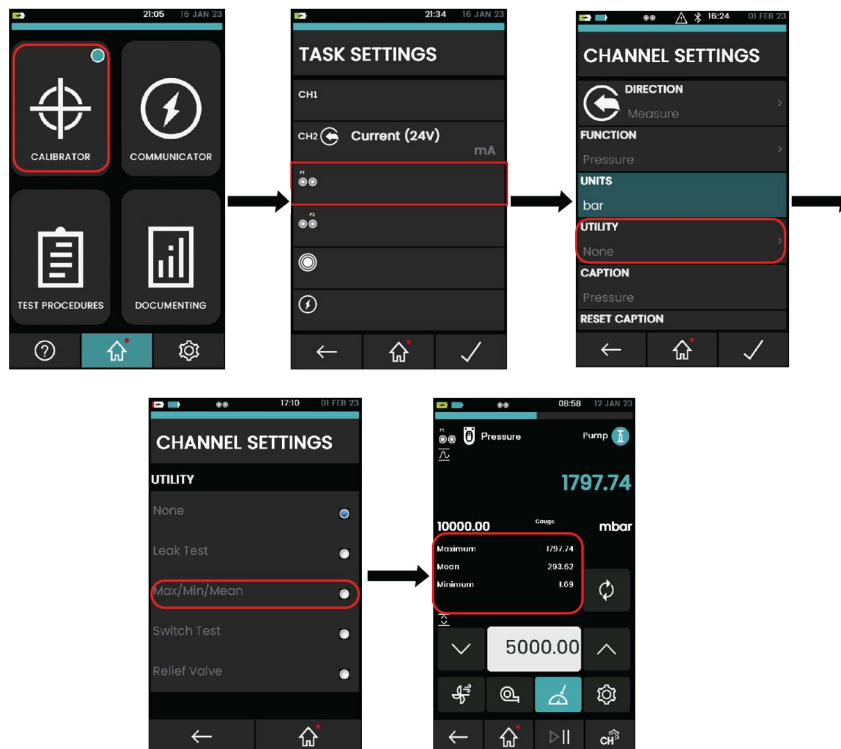

4.4.5 Example Procedure: Relief Valve Test

Pressure relief valves are safety devices that open automatically at a specified pressure to prevent over-pressure conditions in connected equipment. The Relief Valve Test measures the actuation pressure of pressure relief valves.

The user selects either rising or falling mode operation to test positive or negative pressure relief devices. The user then pumps the device up to the actuation pressure. The utility reports maximum or minimum actuation pressure of the test device. Refer to the DPI620G User Manual for more information.

Note: To get the best measurement accuracy, pump slowly when the valve is near to the necessary actuation pressure.

Chapter 4. Pressure Calibrator Operation (DPI620G)

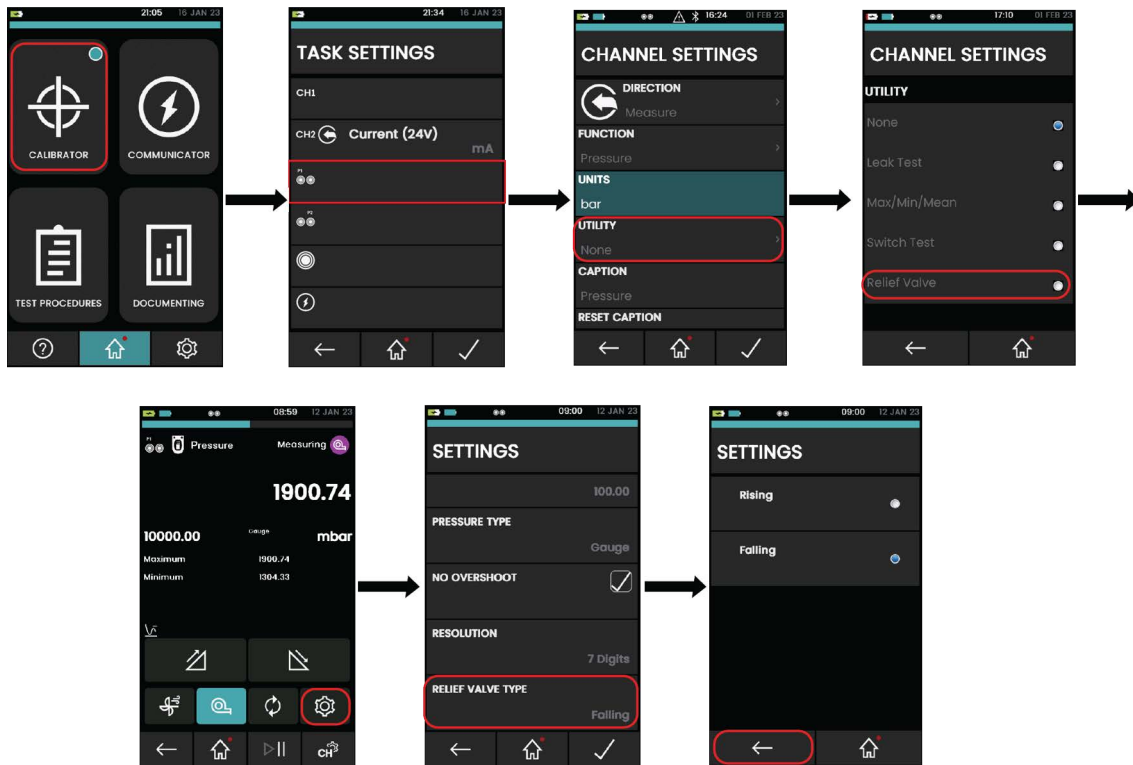

4.4.6 DPI620G Calibrator: Set Up a Switch Test

Pressure switches open or close an electrical circuit when the applied pressure exceeds a specified threshold. Hysteresis is the difference between the applied pressures that start and reset the pressure switch, as illustrated in Figure 4-5.

The switch-test utility measures the actuation pressure and hysteresis of a pressure switch. The actuation pressure measurement uses the hand-pump to make either pressure or vacuum while monitoring the state of the switch and applied pressure. After actuation, the switch hysteresis is measured by slowly venting the applied pressure until the switch changes state again.

With the PV624, you can measure the switch hysteresis automatically by specifying the switch test accuracy (see Figure 4-5), but the pump assistance is necessary for actuation pressure measurement.

When pumping close to the actuation pressure of the switch, slowly decrease the pump rate. Do this to achieve the most accurate measurement of actuation pressure. For example, to achieve an actuation pressure accuracy of 10 mbar: set the switch test accuracy value to 10 mbar/s and the pump rate to be no faster than 100 mbar/s.

4.4.7 Example Procedure: Switch Test

This example shows the procedure to do the switch test.

Refer to the Figure 4-3: Switch testing setup for an example of the physical connections necessary for a switch test.

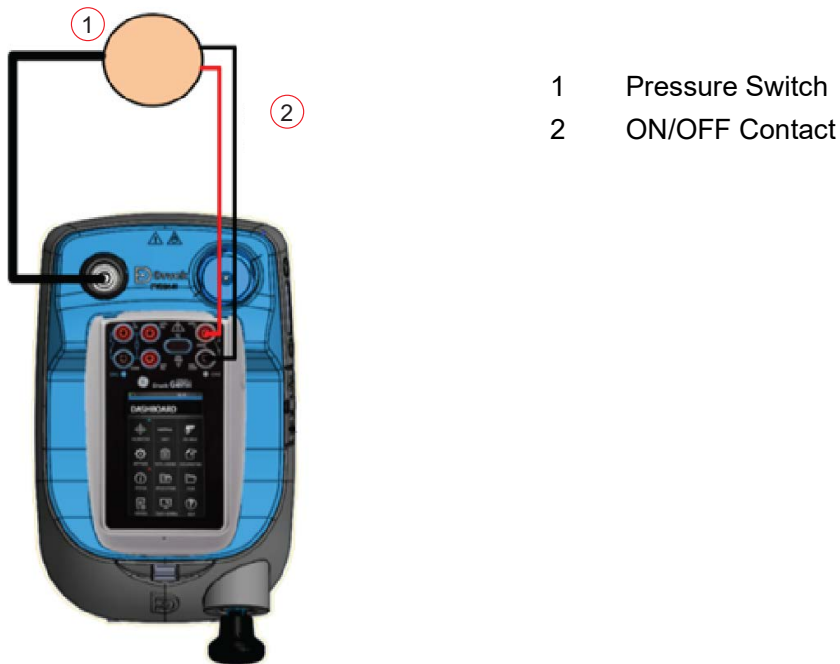

Figure 4-3: Switch Testing Setup

Note: The Switch Test is available with measure or source functions.

4.4.7.1 Switch Test Procedure

Before the start of this procedure, set the accuracy of the Switch Test. An increased value reduces the test time but can make a less accurate capture of switch and overall hysteresis.

If a different accuracy value is necessary, select the **Settings** Icon to show the **Settings** screen that has the **Switch Test Accuracy** function (refer to Figure 4-4 on page 37).

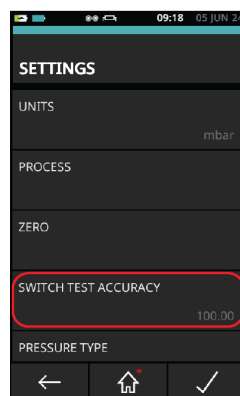



Figure 4-4: Switch Test Accuracy Setting

Refer to Figure 4-5 for the screens to which these instructions relate:

1. Select **Calibrator** on the dashboard.
2. Select the **P1** channel on the **Task Settings** screen.
3. Select **Utility** on the **Channel Settings** screen.
4. Select **Switch Test**.
5. Select the **Ramp Up**  icon to set the PV624 in Pump mode.

Chapter 4. Pressure Calibrator Operation (DPI620G)

- Use the Hand Pump to increase the pressure. Use smaller pump movements as the necessary pressure is approached, until the switch operates (open or closed).
- The PV624 goes into **Measure Mode**. The rising switch pressure (**Opened At** or **Closed At**) will be recorded.

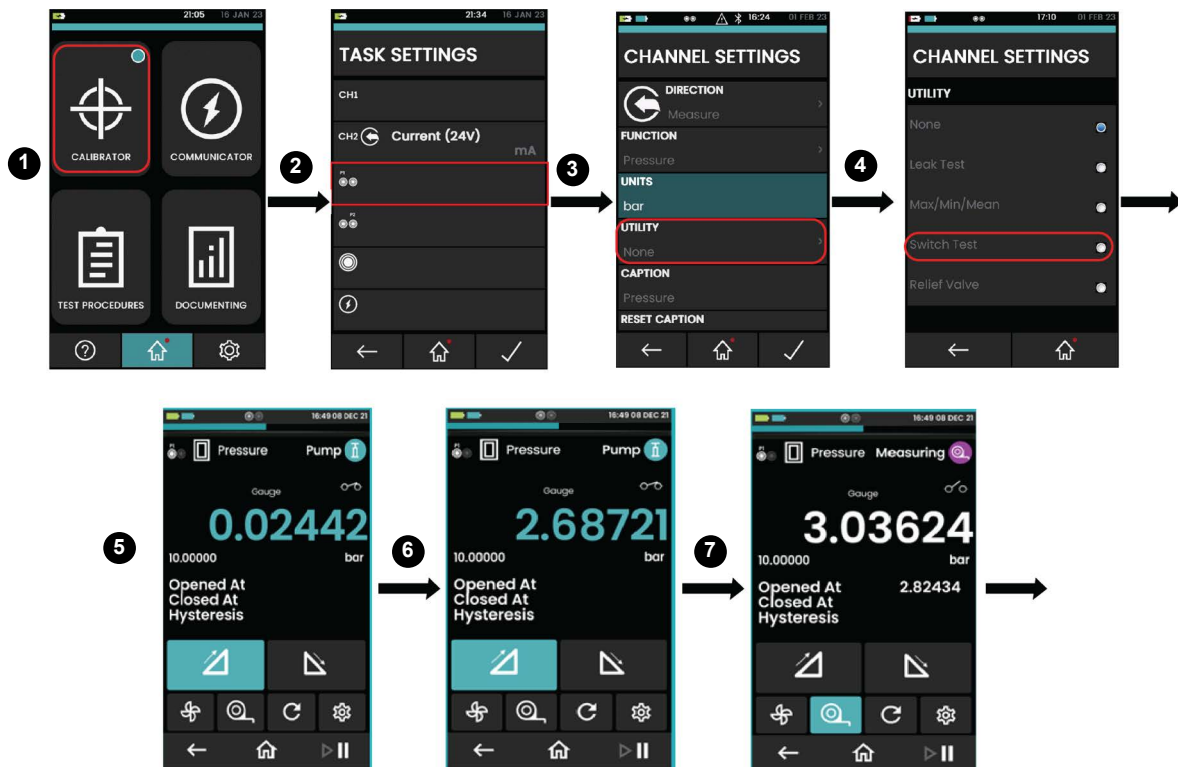

Figure 4-5: Switch Test Example

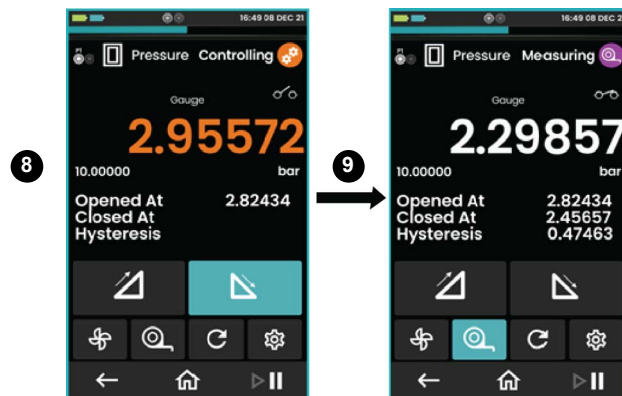



Figure 4-3: Switch Test Example (Continued)

- Select the **Ramp Down**  icon to decrease pressure in the PV624. Refer to Figure 4-4 on page 37 for the set accuracy (measured in bar.)

The display shows:

- Open and closed switch pressure values.
- Hysteresis value.

- Let the pressure decrease until the switch state is recorded. When this occurs, the PV624 will go into measure mode: the falling switch state is recorded (**Opened At** or **Closed At**). The hysteresis is calculated and shown.

If necessary, select the **Reset**  button to do the test again.

4.4.8 Low Pressure Sensors

When used with the DPI620G, the PV624 supports the low pressure PM620 and PM620LP sensors. See “Specification” on page 59. We recommend that you install the latest firmware for the PV624 and DPI620G. See Section 6.9. To have the low-pressure features, you need to install firmware versions greater than V02.00.00 for the PV624 and V06.02.04 for the DPI620G.

Pressure is automatically generated by the PV624 up to 50 mbar into 20 ml of volume for low pressure PM620 and PM620LP modules only. If the pressure is not achievable automatically, the DPI620G will show a range exceeded warning.

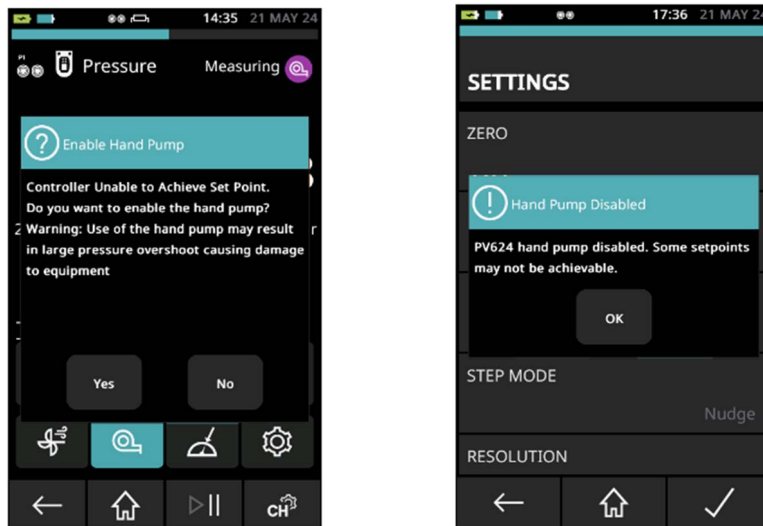

Selecting **Yes** enables the hand pump so you can use it to generate pressure to reach the necessary pressure setpoint. Note that the range exceeded warning also shows that using the hand pump may result in a large pressure overshoot, which could cause damage to all equipment connected. If you enable the hand pump, push it very slowly to gradually increase the pressure. The hand pump will remain enabled until the PV624 is vented and/or turned off. For subsequent pressure setpoints after venting or powering on the PV624, it will again automatically attempt to reach the pressure setpoint. Selecting **No** does not enable the hand pump.

4.4.8.1 ENABLE HAND PUMP Setting

You can enable the hand pump for all low pressure setpoints. Doing this deactivates the automatic pressure generation. Enable the PV624 hand pump through the P1 settings. The display shows an enable hand pump warning when you select 'ENABLE HAND PUMP'. Using the hand pump may give a large pressure overshoot which could cause damage to all equipment connected. If you enable the hand pump, push it very slowly to gradually increase the pressure.

Chapter 4. Pressure Calibrator Operation (DPI620G)

Powering off the PV624 or swapping the low pressure PM620/PM620LP sensor will disable the hand pump. You will then need to re-select the 'ENABLE HAND PUMP ' option if necessary.

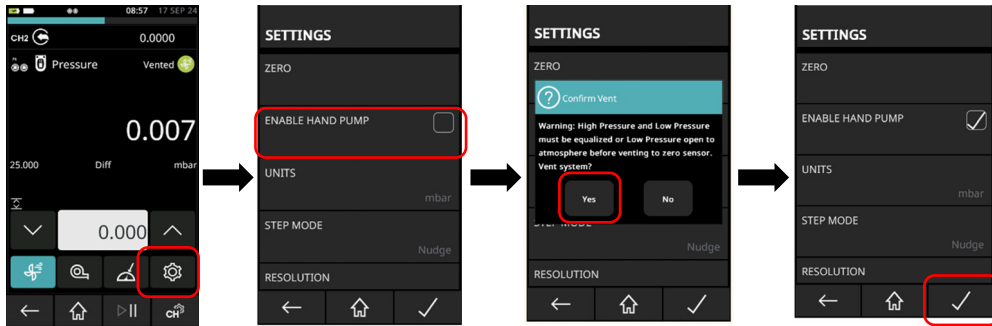

4.4.8.2 PM620LP Zero

We recommend that you zero the differential PM620LP sensors before doing a calibration and/or the temperature has changed by +/- 2°C. To zero the differential PM620LP sensor, use the P1 settings and select **ZERO**. The DPI620G shows a vent warning message asking the user to equalize the high and low pressure sides of the differential connections before the system is vented. If you select **Yes** you can then zero the PM620LP sensor.

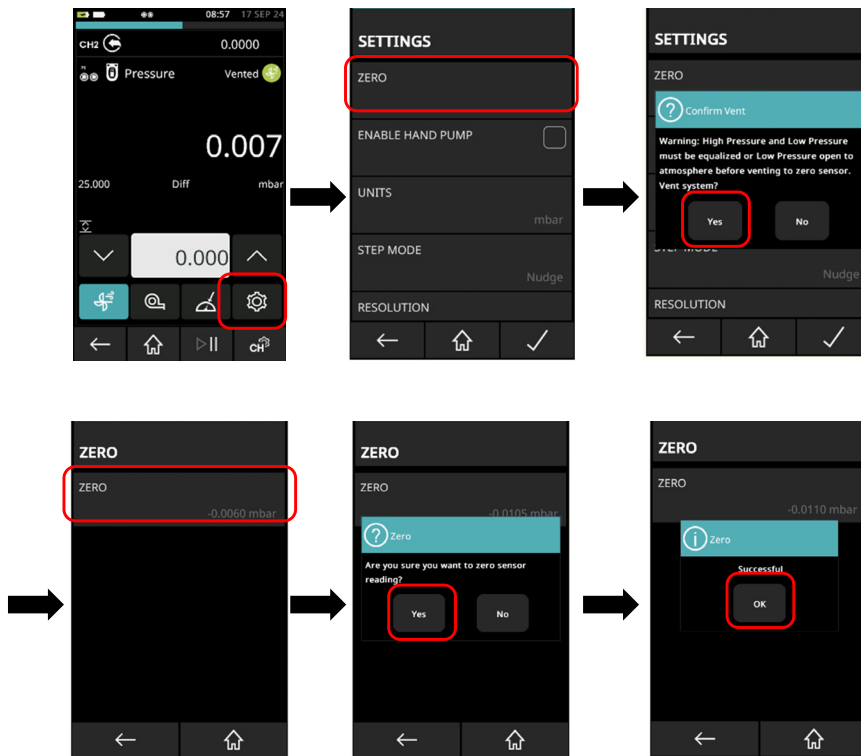

4.4.8.3 PM620LP

When you attach a PM620LP to the PV624, the DPI620G recognizes its full-scale range and differential type as shown in the following image.



4.5 Settings Menu

Use the **Settings**  menu to access the **Status**, **Connections** and **Advanced** sub menu.

4.5.1 Overview of Settings Menu



The **Status** menu has the option to view the **Base** and **Barometer** status and data. For other status options refer to the DPI620G User Manual.

The **Connection** menu has the option to view the Bluetooth connection data.

The **Advanced** menu has the option to do the barometer calibration of PV624 and to adjust the barometer calibration dates.

Chapter 4. Pressure Calibrator Operation (DPI620G)

4.5.2 DPI620G Calibrator: View the Base Battery Status

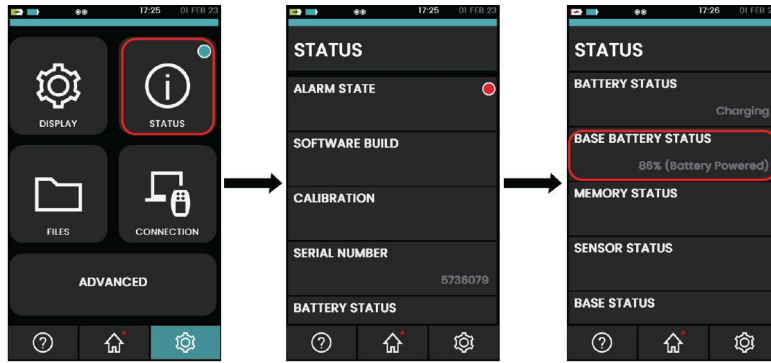

1. To access the **Status** menu refer to Section 4.5.1 on page 41.
2. Select **Status**, then scroll down and select **Base Battery Status**.

4.5.3 DPI620G Calibrator: View the Base Status and Barometer Status

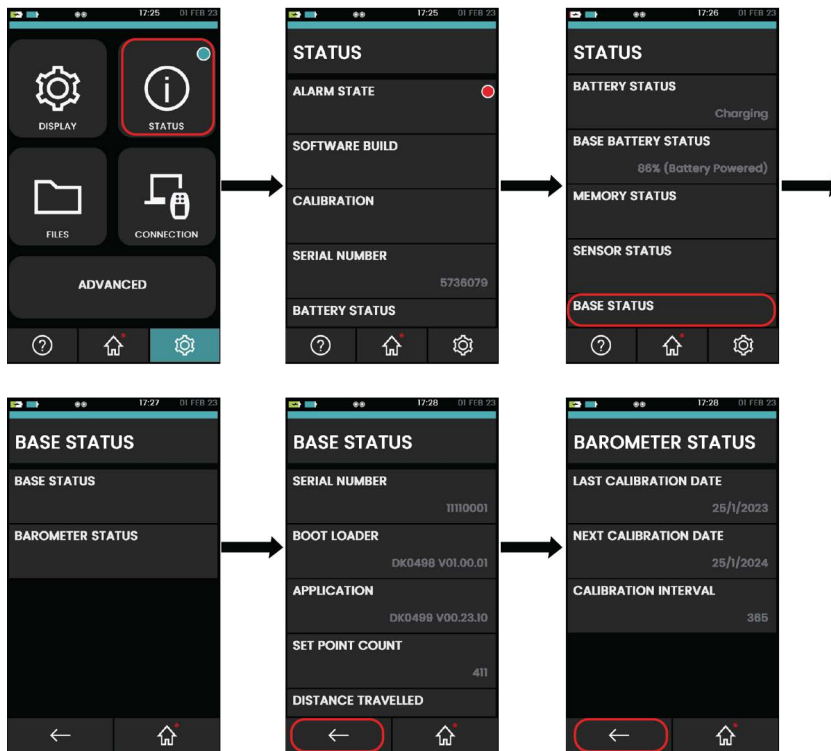

To access the **Status** menu refer to Section 4.5.1 on page 41.

1. Select **Status**.
2. Scroll down and select **Base Status**.
3. Check the details for the **Base Status** and **Barometer Status**.

4.5.4 DPI620G Calibrator: Connect PV624 via Bluetooth

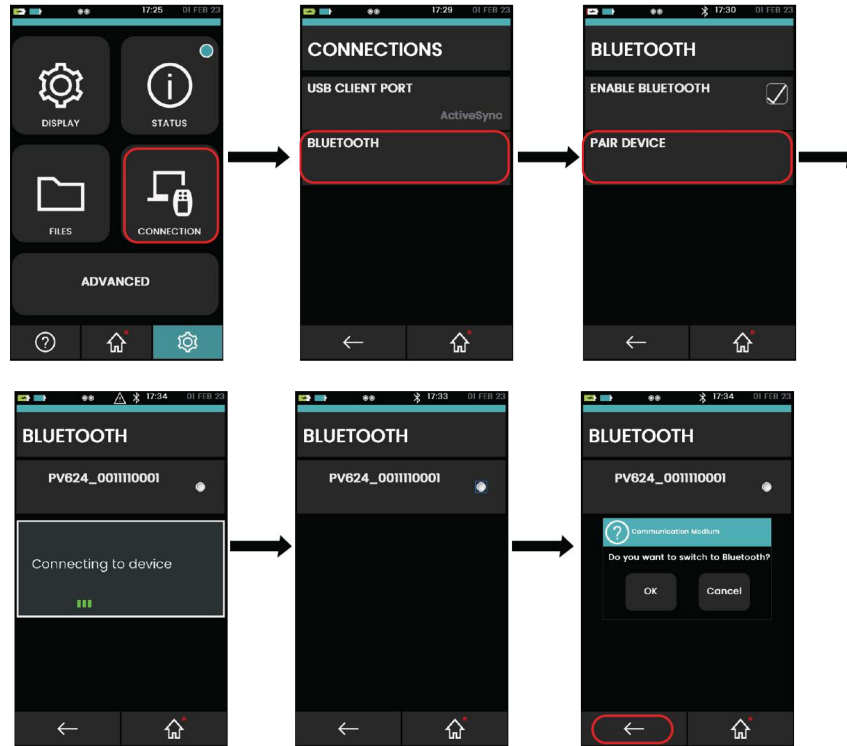

This example shows the sequence to use Bluetooth to connect the DPI620G to the PV624. The Bluetooth option in PV624 lets signals move between the device and the DPI620G, with no physical connection. Calibration tasks are possible when Bluetooth communication is used. To access the **Connections** menu refer to Section 4.5.1.

To **connect**:

1. Select **Connection > Bluetooth > Pair Device**.
2. The display will show that it is searching for devices. Select **OK** to connect to the device.

Note: If the wrong device is paired via Bluetooth, then reset the device and start the pairing process again.

To **disconnect** from the Bluetooth connection:

1. Select the connected PV624 from the **Connections > Bluetooth** menu. Confirm the disconnection from the device.
2. To cancel Bluetooth, select the checkbox for the **Enable Bluetooth** option to remove the tick mark in it.

Chapter 4. Pressure Calibrator Operation (DPI620G)

4.5.5 DPI620G Calibrator: Adjust the Barometer Calibration Date and Interval

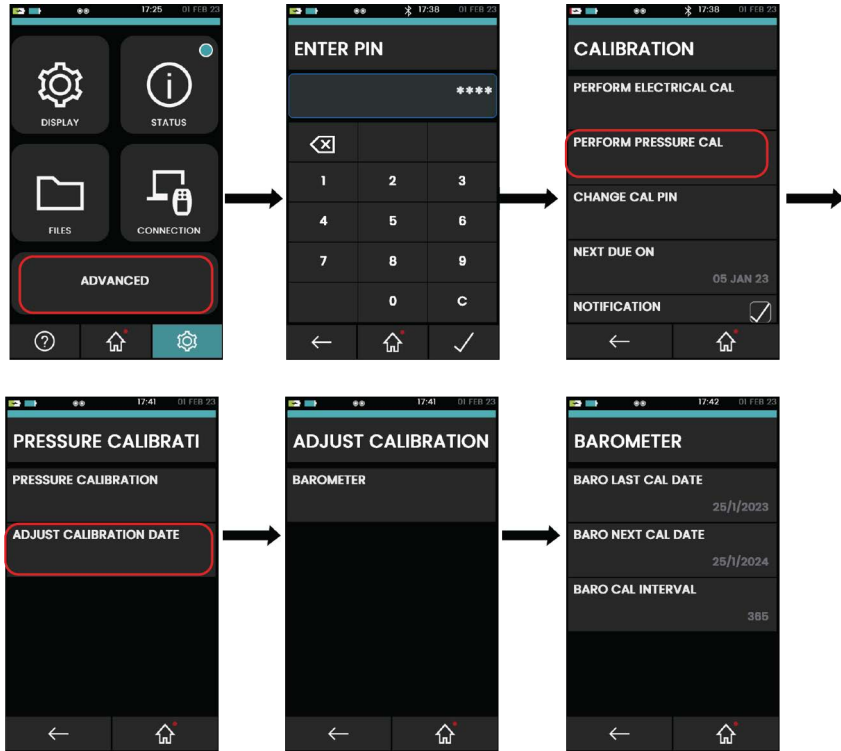

This example shows the sequence to set the barometer calibration date and interval.

To access the **Advanced** menu refer to Section 4.5.1 on page 41.

1. Select **Advanced** > Enter the PIN (4321) > **Perform Pressure CAL** > **Adjust Calibration Date** > **Barometer**.
2. To change the **Baro Last Cal Date**.
 - a. Select **Baro Last Cal Date** to open the **Date** screen.
 - b. Select Day, Month, and Year, as necessary, to change the value move through the list of the variable.
 - c. Select the to set the changes.

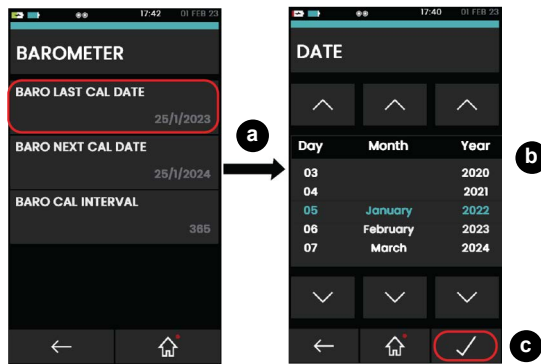

3. To change the **Baro Next Cal Date**.
 - a. Select **Baro Next Cal Date** to open the **Date** screen.
 - b. Select Day, Month, and Year, as necessary. To change the value, move through the list of the variable.

- c. Select the to set the changes.

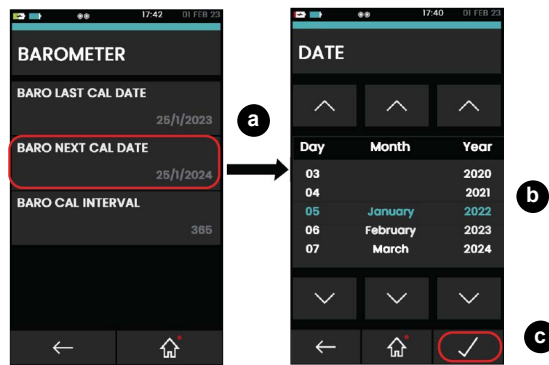

4. To change the **Baro Cal Interval**.

- a. Select **Baro Cal Interval** to set the number of days.
- b. Set the necessary number of days.
- c. Select the to set the changes.

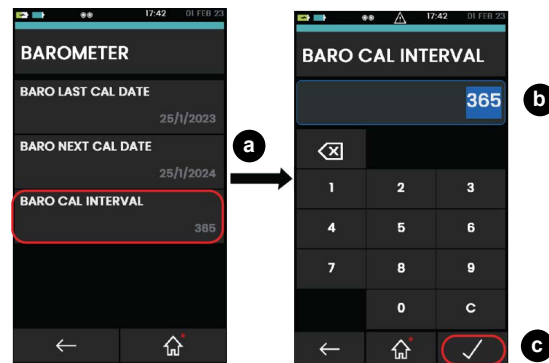

4.5.6 Example Procedure: Internal Barometer Calibration

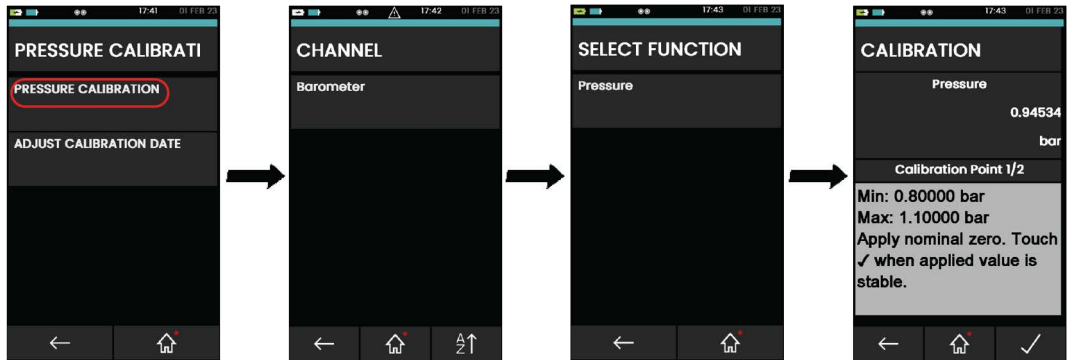

Figure 4-6: Barometer Calibration Setup

To calibrate the internal barometer sensor of the PV624, make sure the correct pressure connection is made from the barometer port to the external calibrated pressure source. Refer to

Chapter 4. Pressure Calibrator Operation (DPI620G)

“Pressure Release Valve and Barometric Port” on page 10. Only approved service centers and approved personnel can do this sensor calibration.



1. Go to the **Pressure Calibration** screen as shown in Section 4.5.5 on page 44.
2. Select the **Barometer**.
3. Select the **Pressure** function.
4. The **Calibration** screen has two sections for a barometer. The top section shows the read value from the internal PV624 barometer. The lower section gives the following information:
 - Function minimum (Min) range (or negative full-scale) value.
 - Function maximum (Max) range (or positive full-scale) value.
 - Calibration procedure step status (visual status boxes and text status).
 - User instructions for each step of the procedure.

Note: Two valid calibration points are necessary for Barometer sensor calibration. Use the following steps on the DPI620G screen to calibrate the internal barometer:

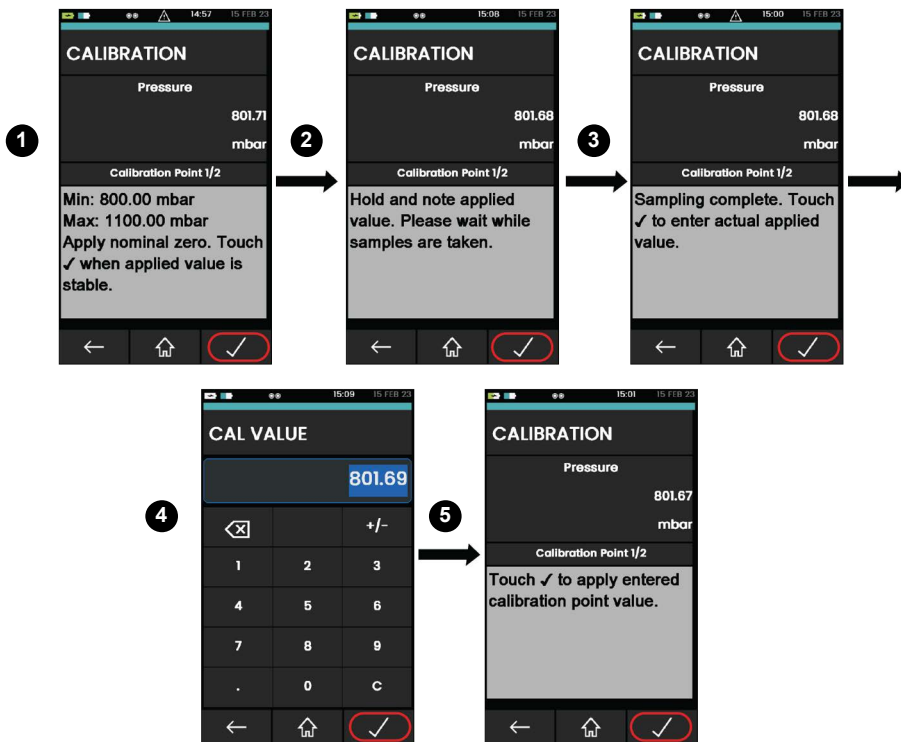

1. Use an external calibrated source of pressure to supply the 800 mbar pressure for the first set point value. Wait for the pressure to become stable. When it becomes stable (between 799.5 mbar to 800.5 mbar) on the external pressure source, select the icon to continue.
2. The screen will show the message “Hold and note applied value. Please wait while samples are taken”. After this, the message changes to “Sampling complete. Select the ✓ icon to enter the measured applied value”. Select the icon to show the **Cal Value** screen.
3. The **CAL VALUE** screen shows the stable measured value. You can use the value read on the external pressure source to change this value: select the icon to continue with this measured value. The screen shows the message “Touch ✓ to apply entered calibration point value”.
4. Select icon to complete Calibration Point 1 and go to the production of Calibration Point 2.

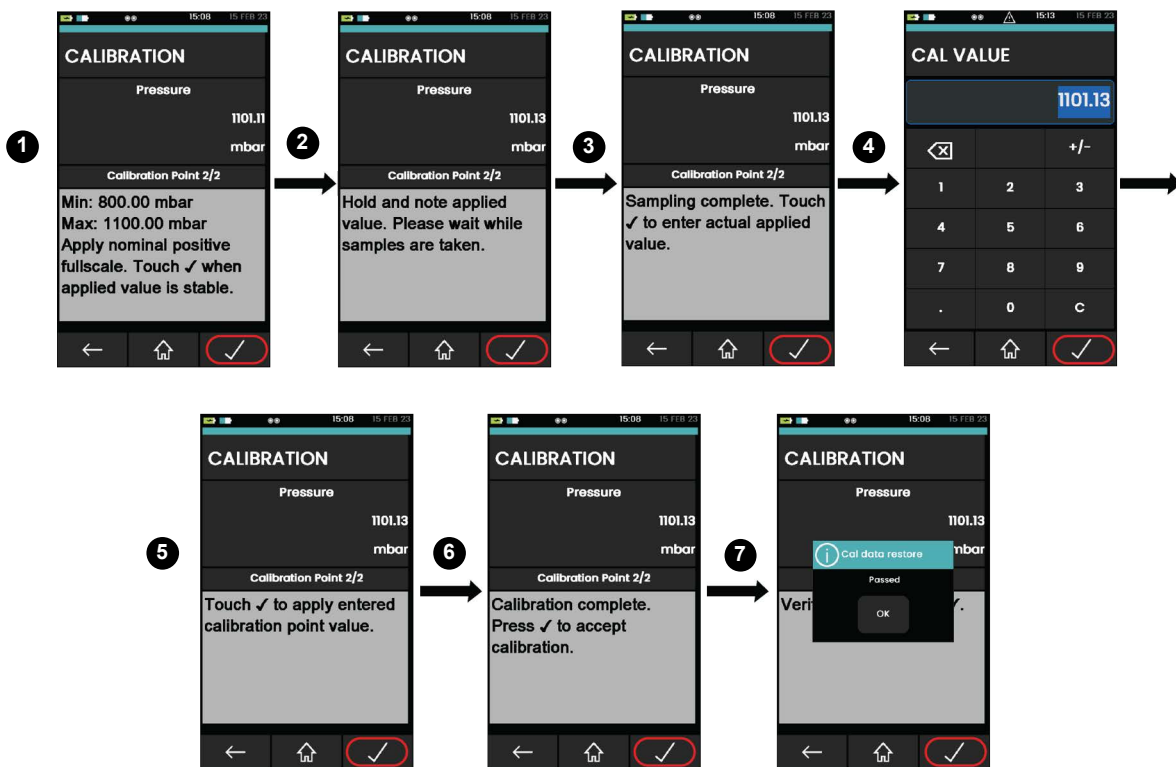



5. Follow Steps 5 to 7, but to begin, use the nominal positive full-scale pressure to the DPI620G.
6. Supply pressure at 1100 mbar for the second point. When the measured pressure indication is stable between 1099.5 mbar to 1100.5 mbar, select icon to continue. The calibration procedure is complete.
7. When you accept readings on the external pressure source for both set points, the screen shows “Calibration complete. Select to accept the calibration”.

After you select the icon in the previous step the screen shows a message window. This window shows that calibration is “Accepted”. Select **OK** to show the **Pressure Calibration** screen.

5. Help Menu

5.1 Overview

The Help  menu provides related information on how to use the instrument. Select the  icon on the dashboard to access the help menu.

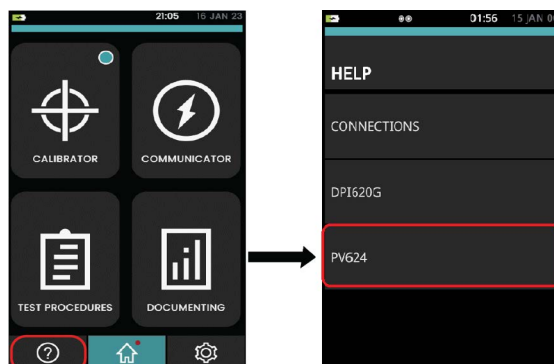

All the information necessary to operate the PV624 and DPI620G is in this menu and gives the following options.

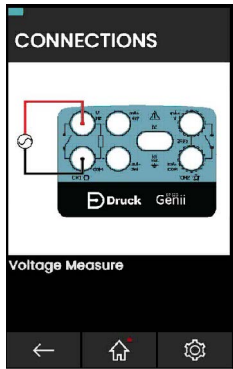
Option	Description
Connections	<p>Select this menu row to show images that give the correct electrical connections for different individual functions. Swipe left or right to view the different diagrams available.</p> 
DPI620G manual	<p>Select this menu row to show these selections:</p> <p>VIEW ONLINE shows a QR code. Use mobile phone to scan the code to access the Help system.</p> <p>VIEW DPI620G MANUAL shows the contents of an online Help document.</p> <p>IMPORT FROM USB imports the Help document into the device memory from an USB memory stick.</p>
PV624 manual	<p>Select this menu row to show these selections:</p> <p>VIEW ONLINE shows a QR code. Use mobile phone to scan the code to access the Help system.</p> <p>VIEW PV624 MANUAL shows the contents of an online Help document.</p> <p>IMPORT FROM USB imports the Help document into the device memory from an USB memory stick.</p>

6. Maintenance Procedures

6.1 Introduction

This chapter gives procedures for the maintenance of the instrument and to keep it in a good condition. Send the instrument to the manufacturer or an approved service agent for all repairs. Table 6-1 summarizes manufacturer recommended maintenance tasks for the PV624.

Table 6-1: Maintenance tasks

Task	Period
Visual Inspection	Before each use
Cleaning	Determined by usage
Calibration	12 months (recommended)

6.2 Service and Repair

THE EQUIPMENT CONTAINS NO USER SERVICEABLE PARTS. INTERNAL COMPONENTS MAY BE UNDER PRESSURE OR PRESENT OTHER HAZARDS. SERVICING, MAINTAINING, OR REPAIRING THE EQUIPMENT MAY RESULT IN DAMAGE TO PROPERTY AND SERIOUS PERSONAL INJURY (INCLUDING DEATH). THEREFORE IT IS PARAMOUNT THAT SERVICE ACTIVITIES ARE UNDERTAKEN ONLY BY A DRUCK AUTHORIZED SERVICE PROVIDER.

REPAIR ACTIVITIES UNDERTAKEN BY UNAUTHORIZED PERSONNEL MAY INVALIDATE THE EQUIPMENT WARRANTY, SAFETY APPROVALS AND DESIGN CONDITION. DRUCK CANNOT BE HELD LIABLE FOR ANY DAMAGES (INCLUDING DAMAGE TO THE EQUIPMENT), MONETARY FINES, PROPERTY DAMAGE OR PERSONAL INJURY (INCLUDING DEATH) THAT MAY OCCUR DURING OR AS A RESULT OF SERVICE MAINTENANCE OR REPAIR WORK UNDERTAKEN BY AN UNAUTHORIZED SERVICE PROVIDER.



WARNING Internal components, such as the Lithium battery pack can become pressurized or create other dangers if not used correctly.

For more details, refer to the rear pages for our service support.

6.3 Visual Inspection

To make sure of continued safe operation, examine the instrument before use. Check for signs of damage (for example: cracks in the body, pressure connector damage or pressure leakage).

6.4 Clean the Unit

Clean the device body with a moist, lint-free cloth and a mild detergent. Do not use solvents or abrasive materials.



CAUTION To prevent damage to the instrument, do not let dirt get into the pressure mechanism.

6.5 Leak Test

Table 9-2 gives the maximum leak rates for each type of PV624 pressure station.

6.5.1 Preparation

To do a leak test, use these items:

- a DPI620G calibrator

Chapter 6. Maintenance Procedures

- the applicable PM620/PM620T module for the pressure station: P/N IPM620-13G (20 bar)
- an applicable blanking adapter to seal the Test Port connection.

6.5.2 Procedure

1. Seal the Test Port connection with the Blanking Plug.
2. Attach the applicable PM620/PM 620T module
3. Connect a DPI620G Calibrator and energize the device (push the Power button).
4. Do a leak test for maximum pressure or maximum vacuum.

6.5.2.1 Maximum Pressure Test

1. Use the applicable procedure for the pressure station to set the maximum pressure - refer to Chapter 3 on page 15. Set the pressure to 20 bar.
2. Set the DPI620G Calibrator to do a Leak Test: refer to Section 4.4.3 on page 33
 - Channel Settings: **Units = Bar; Utility = Leak Test**
 - Settings: **Test Time = 00:01:00** (1 minute)
3. Let the pressure stabilize for 1 minute.
4. Start the test. When the test ends, compare the result with the specified leak rate; refer to Table 9-2.

6.5.2.2 Maximum Vacuum Test

1. Use the applicable procedure for the pressure station to set the maximum vacuum, - refer to Chapter 3 on page 15. Set the pressure to -900 mbar.
2. Set the DPI620G Calibrator to do a Leak Test: refer to Section 4.4.3 on page 33.
 - Channel Settings: **Units = Bar; Utility = Leak Test**
 - Settings: **Test Time = 00:01:00** (1 minute)
3. Let the pressure stabilize for 1 minute.
4. Start the test. When the test ends, compare the result with the specified leak rate; see Table 9-2.

6.6 Replacement of Battery



To remove and replace the battery:

1. Use a screwdriver to loosen the two screws until you release the battery cover.
2. Pull on the two screws to remove the cover, then pull the battery out.
3. When you insert the battery make sure its electrical connections point inwards.
4. Put the battery cover in position. Use a screwdriver to tighten the two screws to set the cover.



INFORMATION Leave the battery in the device for 24 hours to get maximum accuracy of all measurements. The device does not have to be energized (power on) during this period.

6.7 Spares

Contact us for advice or technical support for spare parts. See rear pages.

6.8 Instrument Return

6.8.1 Returned Goods Procedure

If the unit has to be calibrated or is not serviceable, please send it to the nearest Druck Service Centre. See rear pages for details.

Contact the Service Centre to get a Return Goods Authorization (RGA). If you are in the USA, get a Return Material Authorization (RMA). Give this information on either a RGA or RMA:

- Product code
- Serial number
- Details of defect/work to be done
- Error code(s) if applicable
- Conditions of operation.

6.8.2 Instrument Disposal

Do not discard this product as household waste. Contact us for more information on product recycling and use an approved organization that collects and/or recycles unwanted electrical and electronic equipment.

For more information contact either our Customer Service Department (see rear pages), or your local government office.

6.9 Firmware Upgrade

Refer to End User Software Release Note (EUSR) for the full procedure to upgrade firmware in the PV624.

7. Test Procedures

7.1 Overview

This chapter gives examples of how to complete a documented calibration of Device Under Test (DUT) equipment or of assets using specified test procedures.

When you use test procedures to calibrate DUTs, the test details and results of the calibration are saved in DPI620G memory. This data can also be transferred to a PC for more analysis or post-calibration tasks.

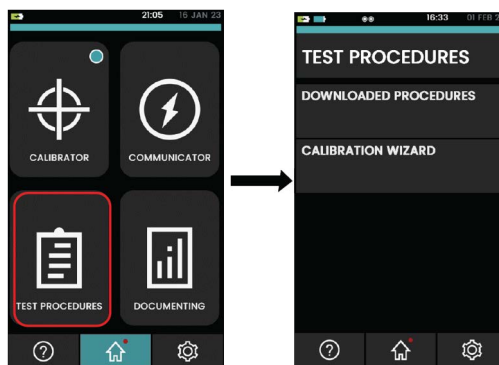

7.2 Downloaded Procedures

Use the '**DOWNLOADED PROCEDURES**' option to complete a calibration that have been downloaded from the 4Sight2™ software. The 4Sight2™ calibration procedure has all the values necessary to calibrate a device under test (For example: test points, ramp time).

Select the Test Procedure icon on the Dashboard to access the 'Downloaded Procedures' function.

Refer to the user manual - K0541 for how to upload and download files by the use of the 4sight2 application.

7.3 Calibration Wizard

Use this function to make, save, and operate the test procedures. Use the test procedures for one test or multiple times for different devices under test. Test procedures can be created and stored for future use.

Refer to the user manual - K0541 for more information.

8. Error Messages

An error message is information shown to the user when an unexpected condition occurs. Error message indicates that an action cannot be completed because of a system error. Error messages are used when user intervention is necessary, to show that a necessary operation did not operate correctly.

8.1 PV624 Error Codes

The following table gives descriptions of different error codes and messages and remedial actions which the user gets from the DPI620G display.

Table 8-1: General Error Codes

Code	Type	Message	Corrective/Recommended Action
0	Low Reference Sensor Voltage	Base Warning - Poor communications to PM. Ensure contact ring and pins are clean and dry	Poor communications to PM. Ensure contact ring and pins are clean and dry. Try connection of alternative sensor. If not recoverable, please contact service center.
2	Barometer Sensor Fail	Base Error - Barometer Sensor Failed. Manually release pressure from the system and check the barometer connection to atmosphere is not blocked	Manually release pressure from the system using the manual outlet. Check barometer connection to atmosphere not blocked. If not recoverable, please contact service center.
3	Stepper Controller Fail	Base Error - Controller failed. Power off, manually release pressure from the system & power on	Switch off unit, manually release pressure from the system and energize the unit. If this persists, please contact service center.
4	Low Motor Voltage	Base Error - Motor failed. Power off, manually vent system & power on	Switch off unit, manually release pressure from the system and energize the unit. If this persists, please contact service center.
5	Over pressure	Base Error - Over pressured. Vent system automatically or with manual vent	Vent system automatically or with manual vent.
6	Low Valve Voltage	Base error - low valve voltage	Not Recoverable. Please contact service center.
7	Persistent Memory Fail	Base error - memory failure	Not Recoverable. Please contact service center.
8	Low Battery Warning	Base Warning - Low battery - System will vent shortly. Please charge the PV624	Charge Base.
9	Critical Battery Warning	Base Error - Critical battery - System Venting and Disconnecting. Please charge the PV624	Charge Base.

Chapter 8. Error Messages

Table 8-1: General Error Codes

Code	Type	Message	Corrective/Recommended Action
13	Over Temperature	Base Error - Over temperature - Switch off the base and allow it to cool	DPI620G will disconnect from PV624 to prevent further operations. Switch off base and allow it to cool.
14	Optical Board Not Found	Base error – optical sensor failed	Not Recoverable. Please contact service center.
17	Battery Communication Failure	Base Error - Battery Communication failed. Check Battery is connected	Check Battery is connected correctly. If issue persists, contact service center.
18	Battery Charger Communication Failure	Base error - battery charger communication failure	Not Recoverable. Please contact service center. The device battery cannot be charged. DPI620G will not be able to indicate battery charging state.
20	OS Error	Base error - OS error	Not Recoverable. Please contact service center.
23	Due for Service	Base Warning - PV624 is Due for Service	Service is recommended but this warning does not stop device operation. “Due for Service” message is shown when distance traveled is 960 m (which is equivalent to 5000 pressure cycles.) It is recommended to service the device before 1000 m. The “Barometer due for Calibration” message. The display will show this message if calibration is due in less than 30 days of the next set PV624 calibration.

9. Specification

9.1 PV624 Pressure Station

Table 9-1: PV624 General Specification

Operating temperature	0 to 50°C (32 to 122°F)
Storage temperature	-20 to 70°C (-4 to 158°F)
Ingress protection	IP54
Humidity	Up to 95% non-condensing
Shock/Vibration	As per MIL-PRF-28800F (Class II equipment).
Altitude	Up to 3000 m
EMC	Electromagnetic compatibility: CE and UKCA approved IEC61326-1
Electrical safety	Electrical - CE and UKCA approved IEC61010
Pressure safety	CE and UKCA approved Sound Engineering Practice.
Approvals	CE Marked, UKCA marked
Size (L: W: H)	(L) 343 mm/13.5" x (W) 192 mm/7.6" x (H) 136 mm/5.4
Weight	PV624 only: ≈ 3.4 kg/7.5 lb
Pressure connections	Quick fit with G1/8 female + 1/8 NPT female adapter.
Power supply	15 V, 2 A (30 W)
Battery life (from 100% charge)	Minimum of 8 hours continuous use (typical)
Battery charge time	8 hours
Battery storage temperature	Max -20 to 50°C (-4 to 122°F) Recommended -20 to 25°C (-4 to 77°F)
Service	>5000 pressure cycles
Power failure protection	System lock and manual vent valve feature provided.
Connectivity	USB client micro-USB (+Bluetooth low energy for B1 option).
Barometer calibration port	G1/8
Test volume materials	Stainless Steel (316 & 306), Zinc plated mild steel, Nitrile rubber, Aluminium BS6082 T6, PVDF plastic, PEEK plastic, FPM rubber, FFPM perfluoro ether rubber, EPDM rubber, PTFE plastic, Polyurethane rubber.

Chapter 9. Specification

9.1.1 PV624 Pressure Data

Table 9-2: PV624 Pressure Specification

Hybrid pressure generation range	-0.9 barg to 20 barg
Hybrid pressure generation compatible PM620 (FS) pressure ranges	0.7 barg (10 psig), 1 barg (15psig), 2 barg/abs (30 psig/abs), 3.5 barg/abs (50 psig/abs), 7 barg/abs (100 psig/abs), 10 barg/abs (150 psi), 20 barg/abs (300 psig/abs).
Maximum over range pressure (without damage)	20% of FS pressure
Barometer pressure measurement range	800-1100 mbar abs
Barometer total uncertainty (24hr)	<0.5 mbar
Barometer drift/year	<0.33 mbar/yr typical
Pressure control stability	50 ppm = 25 mbar PM620/PM620LP FS 100 ppm – 12.5 mbar Diff PM620LP FS 500 ppm – 2.5 mbar Diff PM620LP FS
0 barg to 2 barg +/-50 ppm into 15 ml volume	<15 sec
0 barg to 20 barg +/-50 ppm into 50 ml volume	<90 sec
Maximum leak rate at 20 barg with 50 ml volume	60 mbar/min

9.2 PM620/PM620T Modules

Table 9-3: PM620/PM620T General Specification

Operating temperature	-10 to 50°C (14 to 122°F) Calibrated range: 0 to 50°C (32 to 122°F)
Storage temperature	-20 to 70°C (-4 to 158°F)
Ingress Protection	IP65
Humidity 0 to 30°C (32 to 86°F): 30 to 50°C (86 to 122°F):	Relative humidity (RH) 0 to 95% RH non-condensing 0 to 60% RH non-condensing
Shock/Vibration	Def Stan 66-31, 8.4 cat III
EMC	Electromagnetic compatibility: BS EN 61326-1
Electrical safety	Electrical - BS EN 61010-1
Pressure safety	Pressure Equipment Directive - Class: Sound Engineering Practice (SEP)
Approved	CE Marked
Size	Length, Diameter ≈ 58 x 44 (2.3 x 1.7 in)
Weight	Maximum: ≈ 0.11 kg (0.2 lb)
Pressure connections	Positive (male) port: Attaches to PV624 pressure station only M5 (female) reference pressure port.

9.2.1 Pressure Data (PM620/PM620T Modules)

Table 9-4: PM620/PM620T Maximum Working Pressure

Ranges:	MWP
≤ 350 mbar (5 psi)	2 x FS
> 350 mbar (5 psi)	1.2 x FS

9.3 PM620LP Module

Table 9-5: PM620LP General Specification

Operating temperature	10 to 30°C (50 to 86°F)
Storage temperature	-20 to 70°C (-4 to 158°F)
Ingress Protection	IP65
Humidity 0 to 30°C (32 to 86°F): 30 to 50°C (86 to 122°F):	Relative humidity (RH) 0 to 95% RH non-condensing 0 to 60% RH non-condensing
Shock/Vibration	BS EN 61010-1:2010; MIL-PRF-28800F for Class II equipment, 1 m Drop Tested
EMC	Electromagnetic compatibility: BS EN 61326-1
Electrical safety	Electrical - BS EN 61010-1
Pressure safety	Pressure Equipment Directive - Class: Sound Engineering Practice (SEP)
Approved	CE Marked
Size	Length 56 mm, Diameter: 44 mm (2.2 x 1.7 in)
Weight	106 g maximum (0.2 lb)
Pressure connections	High pressure port (male): Attaches to PV624 pressure station only. Barbed connector on M5 female port, low pressure port.

9.3.1 Pressure Data (PM620LP Module)

Table 9-6: PM620LP Maximum Pressures

Range	Pressure
Maximum Intermittent Pressure	2 x FS
Maximum Working Pressure	110% FS
Maximum Static Pressure	250 mbarg (3.6 psig)

Appendix A. COMPLIANCE STATEMENTS

A.1 FCC (USA)

A.1.1 Federal Communication Commission Interference Statement

This equipment has been tested and found to comply with the limits for a Class B digital device, pursuant to Part 15 of the FCC Rules. These limits are designed to provide reasonable protection against harmful interference in a residential installation. This equipment generates, uses, and can radiate radio frequency energy and, if not installed and used in accordance with the instructions, may cause harmful interference to radio communications.

However, there is no guarantee that interference will not occur in an installation. If this equipment does cause harmful interference to radio or television reception, which can be determined by turning the equipment off and on, the user is encouraged to try to correct the interference by one of the following measures:

- Reorient or relocate the receiving antenna.
- Increase the separation between the equipment and receiver.
- Connect the equipment into an outlet on a circuit different from that to which the receiver is connected.
- Connect the equipment into an outlet on a circuit different from that to which the receiver is connected.

FCC Caution: Any changes or modifications not expressly approved by the party responsible for compliance could void the user's authority to operate this equipment.

This device complies with Part 15 of the FCC Rules. Operation is subject to the following two conditions:

1. This device may not cause harmful interference; and,
2. This device must accept any interference received, including interference that may cause undesired operation.

A.1.2 FCC Radiation Exposure Statement

This product complies with the US portable RF exposure limit set forth for an uncontrolled environment and is safe for intended operation as described in this manual. Further RF exposure reduction can be achieved if the product is kept as far as possible from the user body or is set to a lower output power if such function is available.

This transmitter must not be co-located or operated in conjunction with any other antenna or transmitter.

A.2 CANADA

A.2.1 ISED Canada Statement

This device complies with Industry Canada's license-exempt RSSs. Operation is subject to the following two conditions:

1. This device may not cause interference; and
2. This device must accept any interference, including interference that may cause undesired operation of the device.

Le présent appareil est conforme aux CNR d'Industrie Canada applicables aux appareils radio exempts de licence. L'exploitation est autorisée aux deux conditions suivantes:

1. l'appareil ne doit pas produire de brouillage;

Appendix A. COMPLIANCE STATEMENTS

2. l'utilisateur de l'appareil doit accepter tout brouillage radioélectrique subi, même si le brouillage est susceptible d'en compromettre le fonctionnement.

A.2.2 Radiation Exposure Statement

The product complies with the Canada portable RF exposure limit set forth for an uncontrolled environment and are safe for intended operation as described in this manual. The minimum separation distance for portable use is limited to 15mm assuming use of antenna with 2 dBi of gain. The further RF exposure reduction can be achieved if the product can be kept as far as possible from the user body or set the device to lower output power if such function is available.

A.2.3 Déclaration d'exposition aux radiations

Le produit est conforme aux limites d'exposition pour les appareils portables RF pour les Etats-Unis et le Canada établies pour un environnement non contrôlé. La distance de séparation minimale pour l'utilisation portative est limitée à 15mm en supposant l'utilisation de l'antenne avec 2 dBi de gain. Le produit est sûr pour un fonctionnement tel que décrit dans ce manuel. La réduction aux expositions RF peut être augmentée si l'appareil peut être conservé aussi loin que possible du corps de l'utilisateur ou que le dispositif est réglé sur la puissance de sortie la plus faible si une telle fonction est disponible.

Office Locations



<https://druck.com/contact>

Services and Support Locations



<https://druck.com/service>