

XMO2-IDM

User's Manual

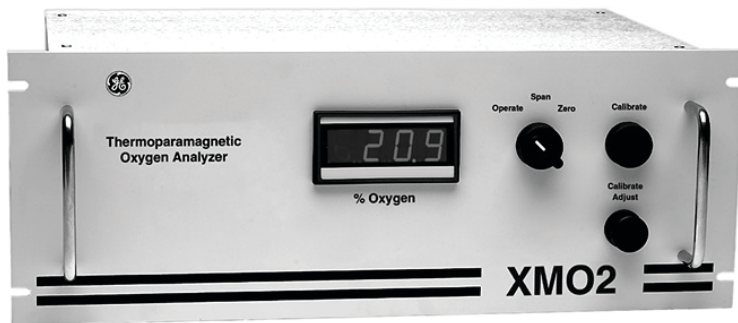

XMO₂-IDM

Oxygen Analyzer

User's Manual

BH056C11 EN H
May 2023

panametrics.com

Copyright 2023 Baker Hughes company.

This material contains one or more registered trademarks of Baker Hughes Company and its subsidiaries in one or more countries. All third-party product and company names are trademarks of their respective holders.

[no content intended for this page]

Information Paragraphs

Note: *These paragraphs provide information that provides a deeper understanding of the situation, but is not essential to the proper completion of the instructions.*

IMPORTANT: These paragraphs provide information that emphasizes instructions that are essential to proper setup of the equipment. Failure to follow these instructions carefully may cause unreliable performance.



CAUTION! This symbol indicates a risk of potential minor personal injury and/or severe damage to the equipment, unless these instructions are followed carefully.



WARNING! This symbol indicates a risk of potential serious personal injury, unless these instructions are followed carefully.

Safety Issues



WARNING! It is the responsibility of the user to make sure all local, county, state and national codes, regulations, rules and laws related to safety and safe operating conditions are met for each installation.

Auxiliary Equipment

Local Safety Standards

The user must make sure that he operates all auxiliary equipment in accordance with local codes, standards, regulations, or laws applicable to safety.

Working Area



WARNING! Auxiliary equipment may have both manual and automatic modes of operation. As equipment can move suddenly and without warning, do not enter the work cell of this equipment during automatic operation, and do not enter the work envelope of this equipment during manual operation. If you do, serious injury can result.



WARNING! Make sure that power to the auxiliary equipment is turned OFF and locked out before you perform maintenance procedures on the equipment.

Qualification of Personnel

Make sure that all personnel have manufacturer-approved training applicable to the auxiliary equipment.

Personal Safety Equipment

Make sure that operators and maintenance personnel have all safety equipment applicable to the auxiliary equipment. Examples include safety glasses, protective headgear, safety shoes, etc.

Unauthorized Operation

Make sure that unauthorized personnel cannot gain access to the operation of the equipment.

Environmental Compliance

Waste Electrical and Electronic Equipment (WEEE) Directive

Baker Hughes is an active participant in Europe's *Waste Electrical and Electronic Equipment (WEEE)* take-back initiative, directive 2012/19/EU.

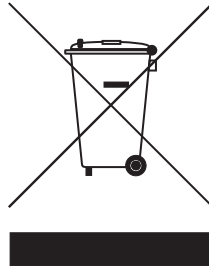

The equipment that you bought has required the extraction and use of natural resources for its production. It may contain hazardous substances that could impact health and the environment.

In order to avoid the dissemination of those substances in our environment and to diminish the pressure on the natural resources, we encourage you to use the appropriate take-back systems. Those systems will reuse or recycle most of the materials of your end life equipment in a sound way.

The crossed-out wheeled bin symbol invites you to use those systems.

If you need more information on the collection, reuse and recycling systems, please contact your local or regional waste administration.

Visit www.bakerhughesds.com/health-safetyand-environment-hse for take-back instructions and more information about this initiative.

Chapter 1. Features and Capabilities

1.1 Introduction1

1.2 Basic Features1

1.3 Theory of Operation 2

1.4 System Components 5

 1.4.1 The XMO2 Transmitter 5

 1.4.2 The Sample System 7

 1.4.3 Long Cables (optional) 7

 1.4.4 Power Supply (optional) 7

 1.4.5 The TMO2D Display/Controller (optional) 7

Chapter 2. Installation

2.1 Introduction 9

2.2 Installing the XMO2 Transmitter 9

2.3 Installing the Sample System 10

 2.3.1 A Basic System 10

 2.3.2 Wiring the XMO2 Transmitter 12

 2.3.3 CE Mark Requirements 12

 2.3.4 Grounding the XMO2 Enclosure 12

 2.3.5 Cable Specifications 13

 2.3.6 Accessing Terminal Blocks TB1 and TB2 14

 2.3.7 Wiring the Signal Connections 15

2.4 Establishing the RS232 Communication Link 16

2.5 Connecting to Other Devices 17

 2.5.1 The PS5R-C24 Power Supply 17

 2.5.2 TMO2D Display 17

 2.5.3 LDP Display 18

 2.5.4 XDP Display 18

 2.5.5 Moisture Image/Monitor Series Analyzers 18

 2.5.6 System 1 Analyzer 18

Chapter 3. Startup & Operation

3.1 Introduction 19

3.2 Powering Up the XMO2 Transmitter 19

3.3 Establishing a Sample Gas Flow 19

3.4 Analog Output Calibration Options 21

3.5 Factory Calibration Procedures 21

3.6 Enhancing the Factory Calibration 22

3.7 Required Calibration Materials 24

3.8 Preparing for Field Calibration 24

3.9 One-Gas Pushbutton Field Calibration 26

3.10 Two-Gas Pushbutton Field Calibration 27

 3.10.1 Setup 27

 3.10.2 Zero Gas Pushbutton Calibration 28

 3.10.3 Span Gas Pushbutton Calibration 28

3.11 IDM Digital Communication Calibration 29

3.12 The Edit Functions Menu 30

3.13 The Field Cal Menu 31

 3.13.1 Perform Cal 32

 3.13.2 Configure Cal 33

 3.13.3 Calibration Drifts 36

 3.13.4 Clear Calibration 37

 3.13.5 Hold Last Value 37

3.14 Changing the 4-20 mA Analog Output Range 38
 3.14.1 4-20mA Range 39
 3.14.2 4mA Cal 40
 3.14.3 20 mA Cal 40
 3.14.4 4-20mA Test 41
 3.14.5 %O2 Test 41

Chapter 4. Programming with Instrument Data Manager

4.1 Introduction 43
 4.2 The Edit Functions Menu 43
 4.2.1 The Error Handler Menu 43
 4.2.2 4.2.2 Total Drift Error 44
 4.2.3 All Other Error Conditions 45
 4.3 The Factory Cal Menu 46
 4.3.1 Background Gas Labels 46
 4.3.2 Pressure Compensation 47
 4.4 The Advanced Menu 51
 4.4.1 Fast Response 52
 4.4.2 Language 53
 4.4.3 Meter ID 54

Chapter 5. Specifications

5.1 Performance 57
 5.2 Functional Specifications 57
 5.3 Physical Specifications 59
 5.4 Optional Accessories 59
 5.5 Ordering Information 59
 5.6 Calibration Specification 61
 5.7 A Calibration Sheet 62

Appendix A. Two Typical Applications

A.1 Blanketing Gases in Hydrocarbon Liquid Storage Tanks 63
 A.1.1 The Problem 63
 A.1.2 Equipment Used 63
 A.1.3 Basic Operating Procedure 64
 A.1.4 Previous Systems 64
 A.2 Reactor Feed Gases in Formaldehyde Production 65
 A.2.1 The Problem 65
 A.2.2 Equipment Used 65
 A.2.3 Basic Operating Procedure 66
 A.2.4 Previous Systems 66

Appendix B. Outline and Installation Drawings

Appendix C. IDM Menu Maps

Appendix C.

Appendix D. Programming with PanaView

D.1 Introduction 93
 D.2 Wiring the RS232 Interface 93
 D.3 Setting Up the Communications Port 93
 D.1 Adding the XMO2 95
 D.1 Changing Meter Settings 97

Appendix E. CE Mark Compliance

E.1 CE Mark Requirements 101
 E.1 EMI Filter Board 102
 E.2 Wiring the Signal Connections for the Weatherproof Version 103
 E.1 Wiring the Signal Connections for the Explosion/Flameproof Version 105

Appendix F. Certifications

F.1 EC-Type Examination Certificate 107
F.2 IECEx Certificate of Conformity 110

Chapter 1. Features and Capabilities

1.1 Introduction

This chapter introduces you to the features and capabilities of the Panametrics *XMO2 Thermoparamagnetic Oxygen Transmitter*. The following specific topics are discussed:

- **Basic Features** – a brief discussion of the XMO2 Transmitter’s basic features and capabilities
- **Theory of Operation** – details on the sensor’s construction and how the measurements are made
- **System Components** – a description of the available XMO2 options and the required sample system

Note: The XMO2 technical specifications and ordering information can be found in Chapter 5, Specifications.

1.2 Basic Features

The XMO2 Transmitter measures the concentration of oxygen in the 0–100% range in a variety of gas mixtures, and it provides a 4–20 mA analog output signal that is proportional to the oxygen concentration. In performing these measurements, the microprocessor-based XMO2 provides automatic oxygen signal compensation for background gas composition and/or pressure variations. In addition, the XMO2 is equipped with *Fast-Response* software, real-time error detection, and push-button field calibration.

The XMO2 Transmitter offers several unique design features:

- Ultra-stable thermistors and a measuring cell that is temperature-controlled at 45°C (113°F) provide excellent zero and span stability, as well as a high tolerance to ambient temperature variations. Optional measurement cell operating temperatures of 60°C (140°F) and 70°C (158°F) are available for special applications.
- The measurement cell design is resistant to contamination and relatively tolerant of sample gas flow rate variations. As it has no moving parts, the XMO2 performs reliably under the shock and vibration found in many industrial applications.
- The XMO2’s unique “*bridge-within-a-bridge*” measurement circuit and microprocessor-based operation automatically compensate the oxygen signal for variations in the magnetic and thermal properties of the background gas that would otherwise cause measurement errors.
- At high oxygen concentrations, changes in atmospheric pressure have significant effects on the measured oxygen level. However, the XMO2 provides automatic microprocessor-based atmospheric pressure compensation of the oxygen signal for these applications.
- The XMO2 modular construction means that the unit can be field-calibrated quickly and easily. Also, the plug-in measuring cell can be replaced with a pre-calibrated spare in just minutes.
- The XMO2 transmitter, which is available in weatherproof or explosion-proof packaging, is designed to be installed as close as possible to the process sample point. It can be located up to 450 ft (150 m) from the control system, display, or recorder using standard Panametrics cables.
- An RS232 serial communications interface and a multi-level, menu-driven *User Program* provide a convenient means for calibrating and programming the XMO2
- Internal software algorithms along with user-programmed calibration data provide compensation of the oxygen signal for background gas composition, atmospheric pressure, or both background gas composition and atmospheric pressure.
- Panametrics proprietary *Fast-Response* software provides enhanced response times to track rapidly changing processes.
- Sophisticated error-checking software with user-programmable defaults and error limits detects abnormal measurement conditions.
- Pushbutton adjustment of the 4–20 mA analog output zero and span values is a standard feature with the XMO2.
- A *drift calibration* routine provides automatic drift compensation for minor changes in the sensor calibration setting.
- Programmable recalibration is accomplished in the field via a computer interface, with no potentiometers to adjust.

1.3 Theory of Operation

The XMO2 measures the concentration of oxygen in a gas mixture by utilizing the unique paramagnetic properties of oxygen.

As its magnetic susceptibility is approximately 100 times greater than that of most other common gases, oxygen can be easily distinguished from these gases based on its behavior in a magnetic field. Also, oxygen's magnetic susceptibility varies inversely with temperature. Therefore, by carefully combining a magnetic field gradient and a temperature gradient within the XMO2 measuring cell, an oxygen-containing gas mixture can be made to flow along these gradients. This induced gas flow is known as a *magnetic wind*. The intensity of this magnetic wind depends on the concentration of oxygen in the gas mixture.

Figure 1 below shows a flow schematic for the XMO2 measuring cell. Permanent magnets within the cell create a magnetic field, while the cell temperature is controlled at 45°C (113°F) to maintain thermal equilibrium. In addition, the cell contains two pairs of highly-stable, glass-coated thermistors. One thermistor of each pair located inside the magnetic field and the other thermistor of each pair located outside the field. Because the thermistors are electrically heated, a temperature gradient is thus created within the magnetic field.

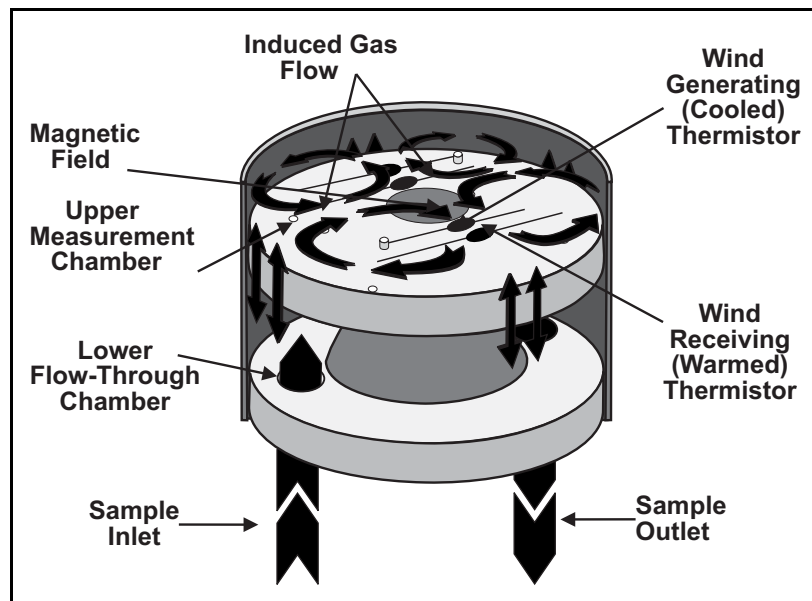

Figure 1: Measuring Cell Flow Schematic

Figure 2 below shows the arrangement of the two thermistor pairs.

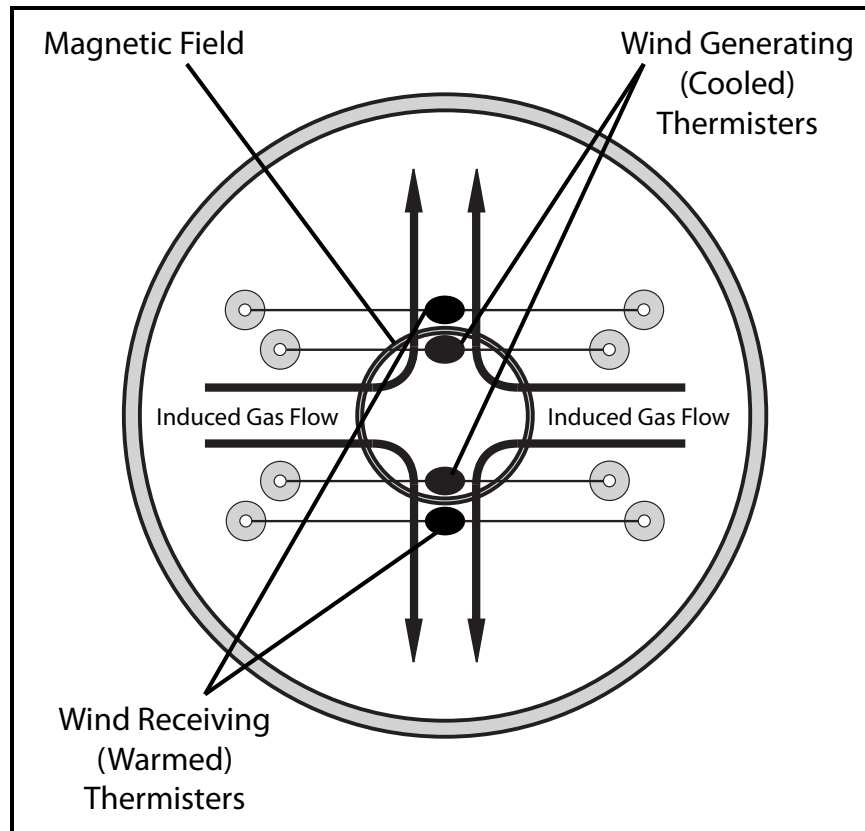

Figure 2: Arrangement of the Thermistor Pairs

A small portion of the sample gas flow is allowed to diffuse from the lower chamber into the upper chamber of the measurement cell. If the sample gas contains a paramagnetic gas such as oxygen, it is attracted to the magnetic field, causing the sample gas pressure to become locally higher in the center of the chamber. At the same time, the sample gas pressure is slightly lower near the thermistors because the high thermistor temperature causes the paramagnetic properties of oxygen to decrease. This slight gradient in sample gas pressure causes the sample gas to flow outward from the center of the magnetic field and over the thermistors. As a result, the inner, wind-generating thermistors decrease in temperature as they lose heat to the magnetic wind. This causes a temperature gradient between the cooler inner thermistors and the warmer outer thermistors.

Figure 3 below shows how the two thermistor pairs are connected in series in an electronic bridge circuit. The bridge circuit becomes unbalanced as the electrical resistance of the thermistors changes with temperature. This circuit imbalance causes a voltage drop, which is proportional to the oxygen concentration in the gas being measured, to appear across the bridge circuit.

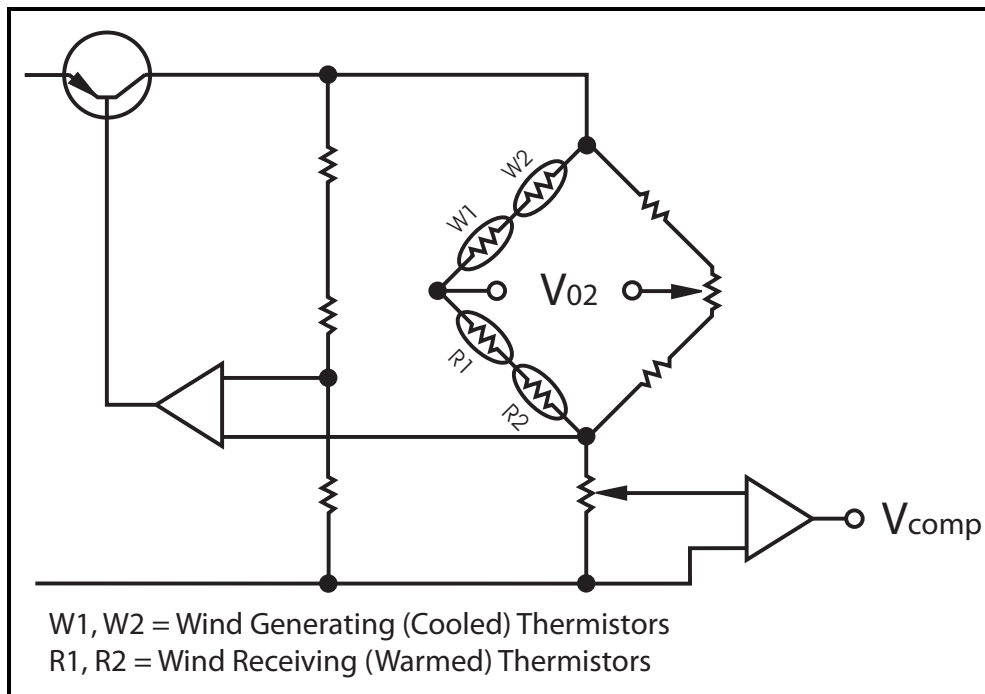

Figure 3: Thermistor Bridge Circuit

As the background gases that comprise the balance of an oxygen-containing gas mixture change, the magnetic and thermal properties of the gas mixture also change. This affects the accuracy and response of any paramagnetic oxygen analyzer. To compensate for such variations, the XMO2 has a unique "bridge-within-a-bridge" design.

The oxygen measuring bridge circuit described on the previous page is itself one arm of another compensation bridge circuit that maintains the oxygen bridge at a constant temperature as background gas composition changes. The electrical power change necessary to keep the oxygen bridge at constant temperature is a function of the thermal properties of the background gas. Therefore, this power fluctuation provides a signal that is related to the thermal conductivity of the background gas. That signal is then used to reduce the effects of the background gas variation on the oxygen span point measurement.

In addition to maintaining a constant oxygen bridge temperature, the XMO2 microprocessor compensates for any zero point shift in the oxygen bridge circuit output caused by background gas changes.

Finally, the bridge circuit voltage is further adjusted for variations in background gas composition and/or atmospheric pressure by internal, microprocessor-based compensation algorithms. The compensated signal is then amplified and converted to a 4-20 mA analog output that is proportional to the concentration of oxygen in the gas mixture.

1.4 System Components

The basic XMO2 measurement system consists of an *XMO2 Transmitter* mounted in a *Sample System*. The sample system is mandatory, and can either be provided by Panametrics or constructed according to our recommendations.

1.4.1 The XMO2 Transmitter

The XMO2 transmitter is self-contained, consisting of the oxygen sensor and associated electronics. It requires a 24 VDC power input @1.2 A maximum at power-up, and it provides a 4-20 mA analog output signal that is proportional to the oxygen concentration of the sample gas and has fully programmable zero and span points. Also provided is an RS232 digital output for oxygen concentration, background gas, and atmospheric pressure signals. Programming, and calibration of the unit may also be performed via this interface.

All XMO2 transmitters include a 10 ft (3 m), 4-conductor cable for connecting the power input and the 4-20 mA analog output. Optional XMO2 accessories available from Panametrics include:

- Power/analog output cable lengths of up to 450 ft (150 m)
- 24 VDC power supply (Model PS5R-C24)
- 3-conductor cable with a DB9 (male or female) or DB25 (male or female) connector for connecting the XMO2 RS232 digital output to external devices

The XMO2 is designed to be installed in a sample system as close as possible to the process sample point. It is available in two environmental packages:

- Weatherproof
- Explosion-proof/Flameproof (with gas inlet and outlet flame arrestors)

The XMO2 transmitter, which is shown in *Figure 4 on page 6*, can be configured for the following standard oxygen ranges:

0 to 1% 0 to 25%
 0 to 2% 0 to 50%*
 0 to 5% 0 to 100%*
 0 to 10% 80 to 100%*
 0 to 21% 90 to 100%*

*Pressure compensation is required

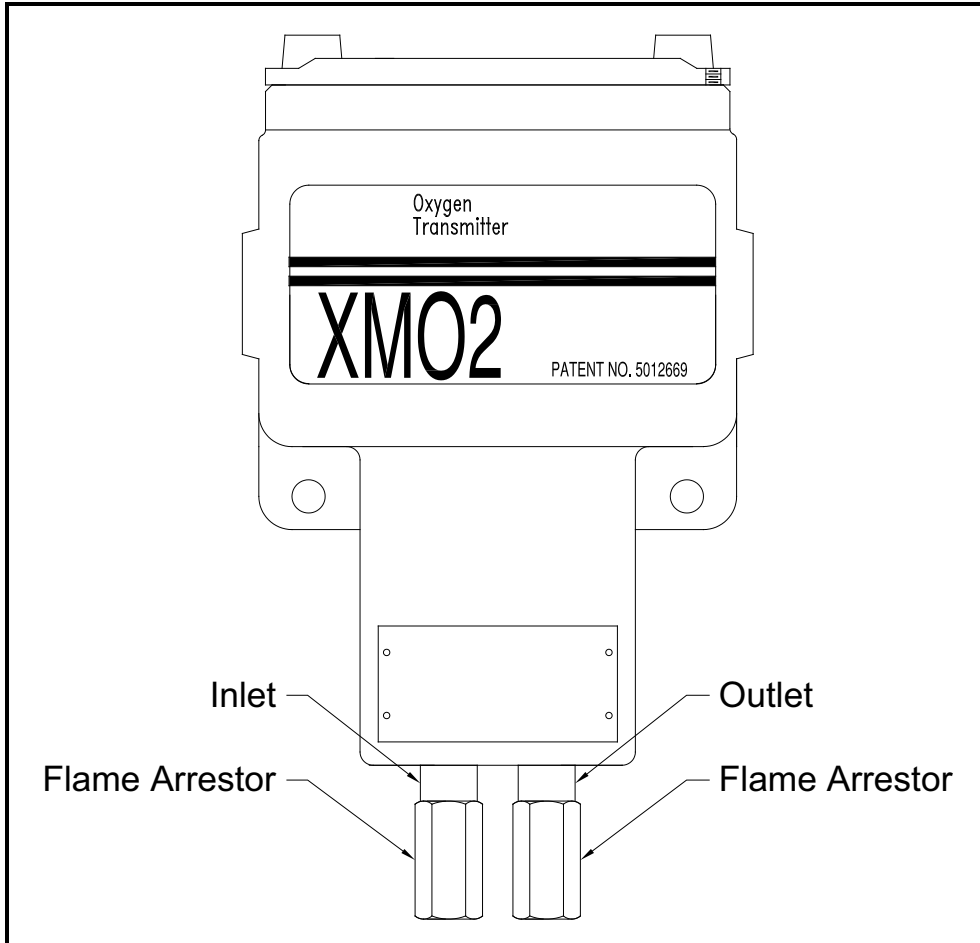

Figure 4: The XMO2 Transmitter

The standard XMO2 transmitter maintains the measurement cell at an operating temperature of 45°C (113°F). An optional 60° (140°F) or 70°C (158°F) cell operating temperature is available upon request.

Note: *The 60° (140°F) or 70°C (158°F) cell operating temperatures should be selected only when necessary, as the higher cell operating temperature results in reduced sensitivity.*

1.4.2 The Sample System

A sample system is mandatory for use with the XMO2 transmitter. The specific design of the sample system depends on the conditions of the sample gas and the requirements of the application. At a minimum, the sample system should include a sample gas flowmeter and a gas flow regulator valve.

In general, the sample system must deliver a clean, representative sample of the gas mixture to the XMO2 transmitter at a temperature, pressure, and flow rate that are within acceptable limits. The standard XMO2 transmitter sample gas conditions are as follows:

- -20° to +40°C (-4° to +104°F), at the standard measurement cell operating temperature of 45°C (113°F)
- Atmospheric pressure
- 1.0 SCFH (500 cc/min) flow rate

Panametrics offers sample systems for a wide variety of applications. A typical sample system for use with the XMO2 transmitter is shown in Chapter 2, *Installation*. For assistance in designing your own sample system, please consult the factory.

IMPORTANT: ATEX compliance requires both:

- *Fast Response* calibration of the XMO2 transmitter
- *Pressure Compensation* of the XMO2 or constant control of the sample system pressure.

1.4.3 Long Cables (optional)

Panametrics provides a standard 10 ft (3 m), 4-conductor, color-coded cable with each XMO2 to connect to the power input and the analog output. Optional cables are available in lengths up to 450 ft (150 m) as P/N X4(*), where * specifies the length in feet. For longer cables or to use your own cable, refer to Chapter 2, *Installation*, for recommendations.

1.4.4 Power Supply (optional)

The XMO2 requires 24 VDC input power at a maximum start-up current of 1.2 A. The Panametrics PS5R-C24 power supply may be used to convert 100-240 VAC to the required 24 VDC.

1.4.5 The TMO2D Display/Controller (optional)

The Panametrics *TMO2D Display/Controller* provides a two-line x 24-character back-lit LCD display for the XMO2's 4-20 mA analog output signal. It also permits display and option programming via its keyboard. Additional features include: recorder outputs, a real time clock, alarm relays, and relays for driving sample system solenoids for automatic zero and span calibration. For more information on the TMO2D, please contact Panametrics.

Chapter 2. Installation

2.1 Introduction

This chapter describes how to install the XMO2 transmitter and its sample system. It also contains information on connecting optional system components. Installation of the XMO2 system consists of three basic steps:

1. Installing the XMO2 transmitter in the sample system (if you purchased your sample system from Panametrics, this step has already been done for you)
2. Mounting, plumbing, and wiring the sample system
3. Making wiring connections for power input, 4-20 mA analog output, RS232 digital output, and optional external devices

2.2 Installing the XMO2 Transmitter

Note: *This section applies only if the XMO2 transmitter has not already been installed in the sample system by Panametrics.*

The sample system must deliver a clean, representative gas sample to the XMO2 at the proper temperature, pressure and flow rate. This usually means a clean, dry gas sample that is free of solid and liquid particulates and is delivered at atmospheric pressure, a temperature no greater than 40°C (104°F), and a flow rate of approximately 1.0 SCFH (500 cc/min). A typical sample system for the XMO2 might include an inlet gas flow regulating needle valve, a sample gas flow meter, and a pressure gauge.

Note: *Because factory calibration of the XMO2 is done at atmospheric pressure and at a flow rate of 1.0 SCFH, operation of the XMO2 at other pressures and/or flow rates requires a field recalibration to ensure optimum accuracy.*

To install the XMO2 transmitter in the sample system, complete the following steps:

1. Select a location in the sample system that provides at least 9 in. (230 mm) of clearance above the top cover of the XMO2 for access to the interior of the transmitter enclosure.
2. Mount the XMO2 transmitter in the sample system via its two mounting holes. Be sure that the transmitter is upright and is level to within $\pm 15^\circ$.
3. Use 1/4" stainless steel tubing to connect the sample system *Inlet* and *Outlet* fittings to the corresponding XMO2 ports.



WARNING! For explosion-proof units, be sure to conform to all safety and electrical code requirements.

2.3 Installing the Sample System

You can order a complete sample system from Panametrics that is mounted on a steel panel and includes the XMO2 transmitter and all necessary components and plumbing. Several standard sample systems are available, and custom-designed sample systems can be built to your exact specifications.

2.3.1 A Basic System

Figure 5 below shows a basic sample system (dwg #732-164) that has been designed for use with the XMO2 transmitter.

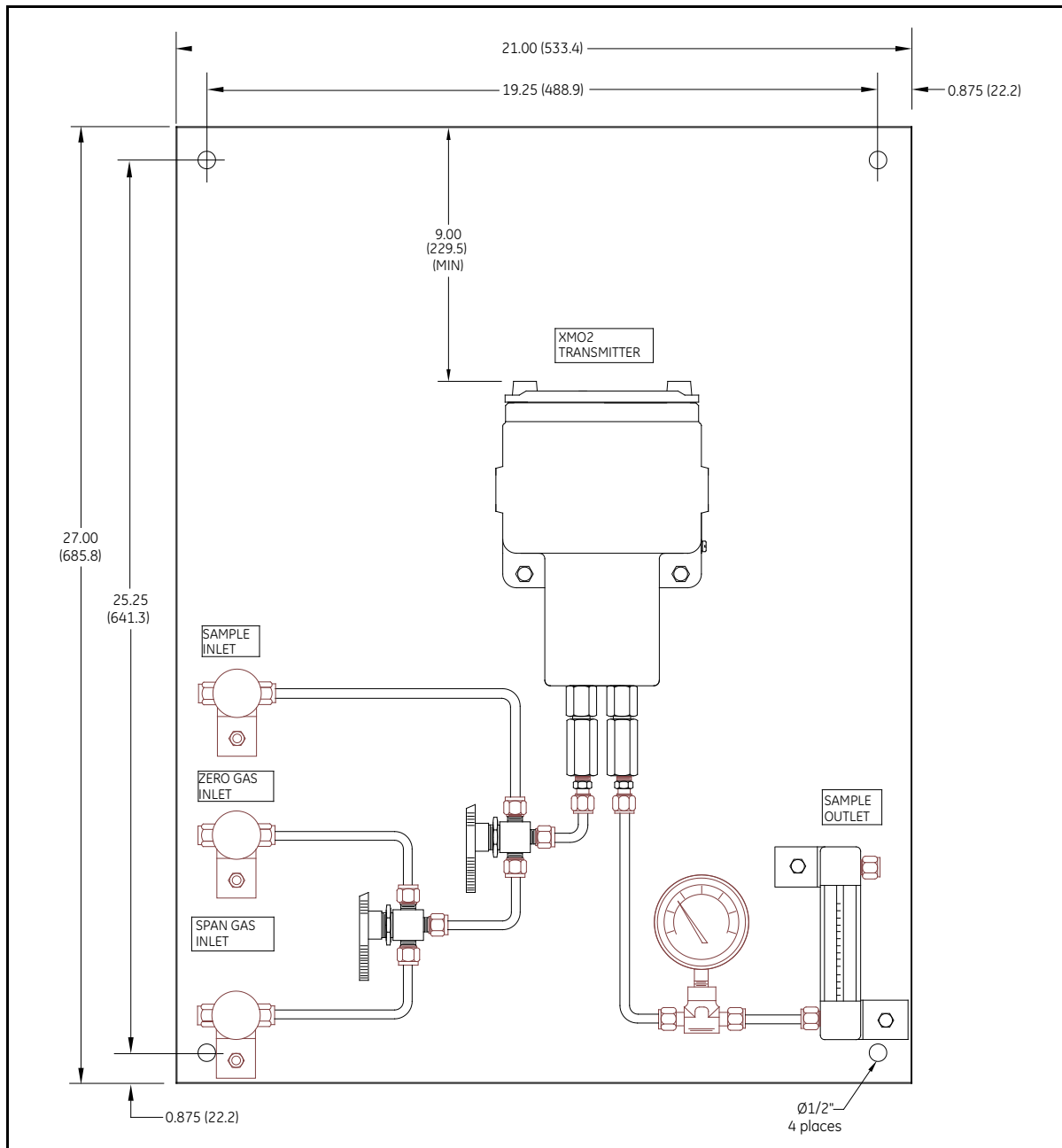

Figure 5: Basic XMO2 Sample System (ref. dwg #732-164)

The sample system shown in Figure 5 on page 10 consists of a painted steel plate with the following components mounted on it:

- Inlet needle valves for sample, zero, and span gas flow regulation
- Ball valves for flow selection
- An XMO2 transmitter
- A sample gas outlet pressure gauge
- A sample gas flowmeter

Other components, such as a pump, a filter/coalescer, or a pressure regulator could be added to the system if needed.

2.3.1.1 Mounting the Sample System

To mount the sample system, complete the following steps:

1. Select a location that is as close as possible to the process sampling point. The ambient temperature at this location should be in the range of -20° to $+40^{\circ}\text{C}$ (-4° to $+104^{\circ}\text{F}$).

IMPORTANT: For locations where the ambient temperature falls below -20°C (-4°F), install the sample system in a heated enclosure.

2. Using the mounting holes provided, fasten the sample system to a convenient vertical surface. The system must be installed in an orientation that keeps the XMO2 transmitter upright and level to within $\pm 15^{\circ}$.
3. After the sample system has been mounted, use $1/4$ " stainless steel tubing to connect all inlet and outlet lines to the $1/4$ " tube fittings on the sample system. The sample line leading from the process to the sample system should be as short as possible in order to decrease system lag time and to prevent condensation in the line.

Proceed to the next section to begin wiring the system.



CAUTION! Always apply power to the XMO2 transmitter immediately after installation, especially if it is mounted outdoors or in a humid area.

2.3.2 Wiring the XMO2 Transmitter

This section describes how to make all necessary electrical connections to the XMO2 system.

2.3.3 CE Mark Requirements



CAUTION! To meet CE Mark requirements, all electrical cables must be grounded and shielded as described in Appendix E.

2.3.4 Grounding the XMO2 Enclosure



WARNING! The XMO2 transmitter enclosure must be properly grounded.

Connect the external ground screw on the XMO2 enclosure (see *Figure 6* below) to a suitable earth ground.

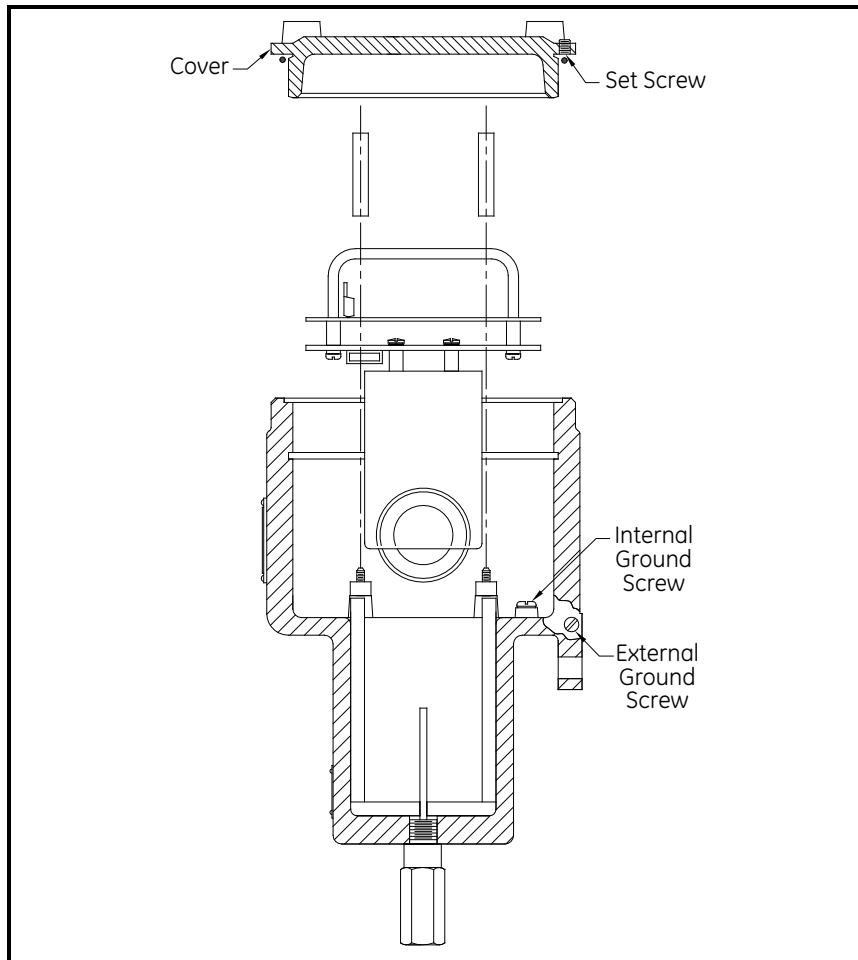

Figure 6: XMO2 Ground Screw Locations

2.3.5 Cable Specifications

Table 1 below shows the transmitter wiring connections using the standard Panametrics XMO2 4-wire cable [P/N X4(L), where L = length in ft]. This cable can be used for distances up to 450 ft (150 m).

Table 1: Panametrics 4-Wire XMO2 Cable

Lead	Color	AWG	Terminal
+24 VDC Line	Red	22	TB1-1
24 VDC Return	Black	22	TB1-2
4-20 mA (+)	White	22	TB1-3
4-20 mA (-)	Green	22	TB1-4

If you are using your own cable to wire the XMO2, refer to Table 2 below for cable requirements.

Table 2: Non-Panametrics Cable Requirements

MAX. CABLE LENGTH		WIRE SIZE	
ft	m	AWG	mm ²
450	130	22	0.35
700	200	20	0.60
1,050	320	18	1.00
1,700	500	16	1.20
2,800	850	14	2.00
4,000	1,200	12	3.00

Table 3 below shows the connections for the Panametrics standard 3-wire RS232 cable (P/N 704-667, -668, -669, or -670-L, where L = length in ft), which is available with a DB-9 or a DB-25 connector (male or female). This cable is available in standard lengths of 6 ft and 12 ft.

Table 3: Panametrics 3-Wire RS232 Cable

Lead	Color	AWG	Terminal
RX	Red	22	TB2-1
TX	White	22	TB2-2
GND	Green	22	TB2-3

See *EIA-RS Serial Communications* (Panametrics document #916-054) for a more detailed discussion of RS232 wiring.

Note: See Figure 64 on page 72 for detailed drawings of the standard Panametrics cables described above.

2.3.6 Accessing Terminal Blocks TB1 and TB2

The 24 VDC power input, 4-20 mA analog output, and RS232 digital output wiring connections are made to terminal blocks TB1 and TB2 inside the XMO2 enclosure (see *Figure 7* below). To access this terminal block, loosen the locking set screw and remove the cover from the transmitter. Then, refer to *Figure 7* below for the location and pin designations of terminal blocks TB1 and TB2.



CAUTION! Do not make any connections to any unused pins on terminal blocks TB1 or TB2.

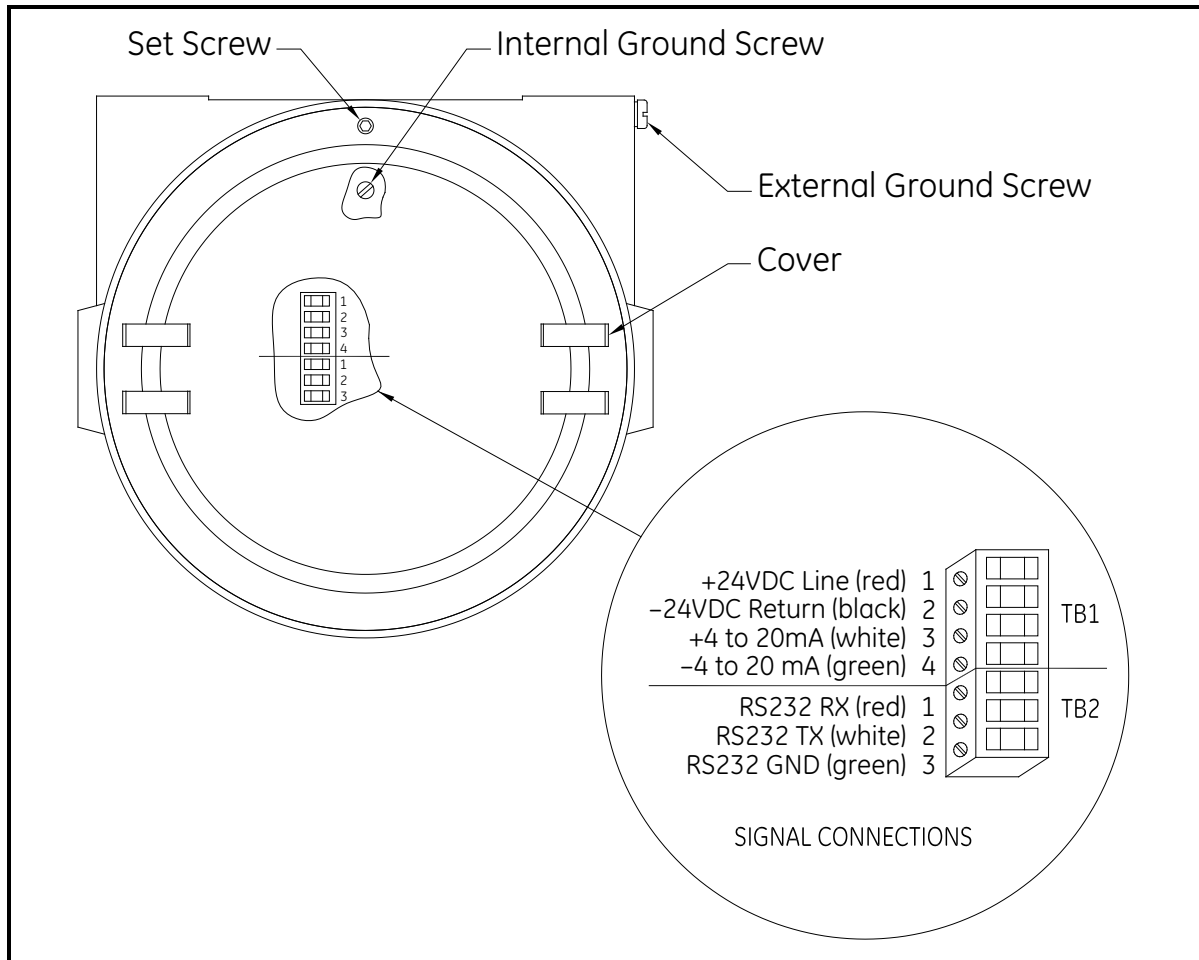

Figure 7: TB1 and TB2 Terminal Block Connections

Proceed to the next section to begin making connections to terminal blocks TB1 and TB2.

2.3.7 Wiring the Signal Connections

Complete the following steps to make the signal connections to terminal blocks TB1 and TB2:

1. Install a cable clamp or gland in one of the 3/4" conduit holes.



CAUTION! Be sure to plug the unused conduit hole to maintain the designated weatherproof or explosion-proof rating.

2. Route the 4-wire and 3-wire (if used) cables through the cable clamp. Then, tighten the clamp to secure the cable(s).
3. Unplug the TB1 and TB2 connectors by pulling them straight off the printed circuit board, and loosen the screws on the side of the connectors.
4. Connect the 24 VDC input power leads as follows:



CAUTION! Connecting the +24 VDC (red) lead to any terminal except TB1-1 will damage the XMO2.

- a. Insert the 4-wire cable +24 VDC line (red) lead into pin TB1-1 and tighten the screw.
 - b. Insert the 4-wire cable 24 VDC return (black) lead into pin TB1-2 and tighten the screw.
5. Connect the 4-20 mA analog output leads as follows:
 - a. Insert the 4-wire cable + 4-20 mA (white) lead into pin TB1-3 and tighten the screw.
 - b. Insert the 4-wire cable - 4-20 mA (green) lead into pin TB1-4 and tighten the screw.
6. Connect the optional RS232 digital output leads as follows:
 - a. Insert the 3-wire cable RX (red) lead into pin TB2-1 and tighten the screw.
 - b. Insert the 3-wire cable TX (white) lead into pin TB2-2 and tighten the screw.
 - c. Insert the 3-wire cable GND (green) lead into pin TB2-3 and tighten the screw.
7. Carefully plug the TB1 and TB2 connectors back onto the printed circuit board, and reinstall the cover on the XMO2.
8. Connect the other ends of the cables to the 24 VDC power supply, the 4-20 mA input of the display/control device, and the serial port of the computer or terminal (see the instruction manuals for those devices for details).

2.4 Establishing the RS232 Communication Link

Before the XMO2 can be programmed, a link between the built-in RS232 digital output and a computer terminal must be established. To accomplish this, proceed as follows:

Note: See *Panometrics document EIA-RS Serial Communications (916-054)* for a details of the RS232 standard.

1. Verify that either Com 1 or Com 2 on the computer is unused.

IMPORTANT: Do not use a virtual Com port, such as Com 3 or Com 4, for communicating with the XMO2.

2. With both the XMO2 and the computer turned OFF, connect a serial cable from the XMO2 to the PC. See Chapter 2, *Installation*, for detailed instructions.



CAUTION! Never make any connections to a computer while it is powered up. Damage to the system may result.

3. Power up the PC and launch the IDM software.

Note: See the *IDM User's Manual (910-185)* for information on installing and launching your program.

4. In the *Global* menu of IDM, select the *Preferences* option to specify the com port to which your XMO2 has been connected.

5. For proper communications with the XMO2, the following com port settings must be specified:

- Baud Rate = 9600
- Data Bits = 8
- Parity = None
- Stop Bits = 1
- Flow Control = Xon/Xoff

6. Select the *Connect to a New Instrument* option, enter the XMO2 ID number (1 to 254), and select *OK*.

2.5 Connecting to Other Devices

This section discusses interconnection of the XMO2 transmitter with other Panametrics devices. The following devices are included:

- PS5R-C24 power supply
- TMO2D display
- LDP display
- XDP display
- Moisture Image/Monitor Series analyzers
- System 1 moisture analyzer

2.5.1 The PS5R-C24 Power Supply

The Panametrics PS5R-C24 power supply converts a 100–240 VAC input to the required 24 VDC output. *Figure 8* below shows the PS5R-C24 connections. As indicated, the AC input *Line*, *Neutral* and *Ground* connections are made to the terminals along the bottom of the panel, while the DC output *+24V line* and *24V return* connections are made to the terminals along the top of the panel. See the instructions provided with the power supply for more details.

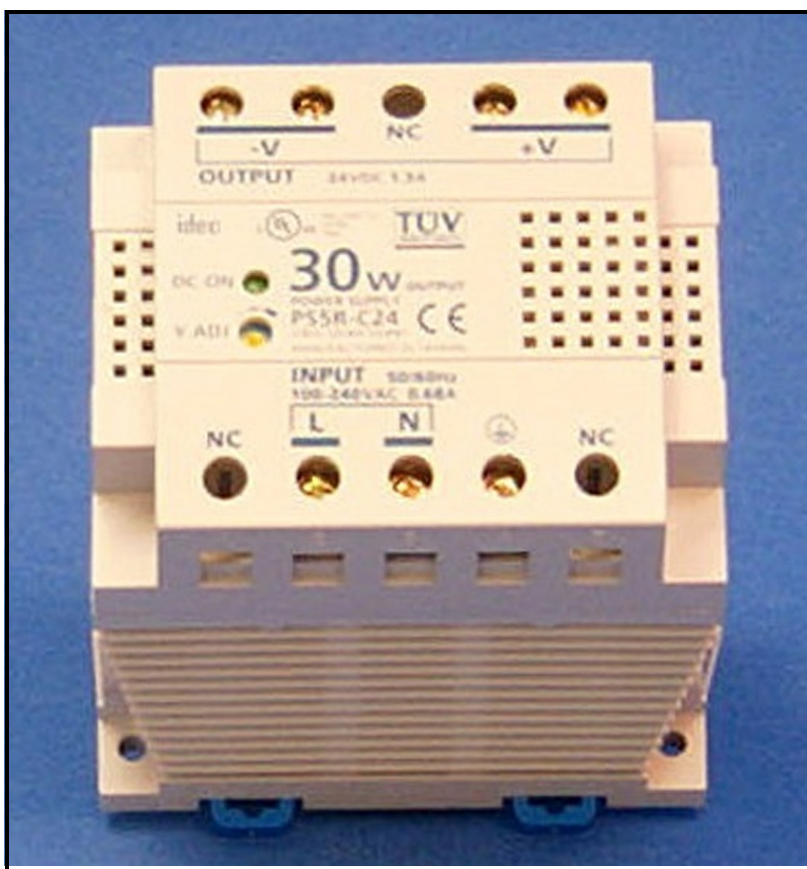

Figure 8: PS5R-C24 Power Supply Connections

2.5.2 TMO2D Display

The Panametrics *TMO2D Display* provides a two-line x 24 character back-lit LCD. It features display and option programming via the keyboard and it offers recorder outputs, alarm relays, and optional relays for driving sample system solenoids for automatic zero and span calibration of the XMO2. See *Figure 74* on page 82 for an interconnection diagram, and refer to the *TMO2D User's Manual* (910-084) for details on its operation.

2.5.3 LDP Display

The *LDP Display* provides an integral, regulated 24 VDC power supply, an adjustable 3-digit display to program the 4-20 mA analog input range, two programmable SPDT alarm relays rated for 1A @250 VAC, and an isolated, independently-adjustable 4-20 mA analog output. The LDP is supplied in an explosion-proof enclosure that is rated for Cenelec EEx d IIC T6 and IP66 (with an optional gasket). See *Figure 74 on page 82* for an interconnection diagram, and refer to the *LDP User's Manual* (910-225) for details on its operation.

2.5.4 XDP Display

The *XDP Explosion-proof Display Package* provides an integral, regulated 24 VDC power supply, a 3-digit display with an adjustable 4-20 mA analog input range, two SPDT alarm relays rated for 1A @250 VAC, and an isolated, independently-adjustable 4-20 mA analog output. See *Figure 74 on page 82* for an interconnection diagram, and refer to the *XDP User's Manual* (910-204) for details on its operation and specifications.

2.5.5 Moisture Image/Monitor Series Analyzers

These Panametrics instruments include the *Moisture Image Series 1* and *Moisture Monitor Series 3* analyzers. These analyzers accept inputs from a variety of sensors (including the XMO2) and offer graphical and digital interfaces. See *Figure 74 on page 82* for interconnection diagrams, and refer to the *User's Manual* (910-108 or 110) for details on its operation.

Note: An external 24 VDC power supply (such as the PS5R-C24) is required to use the XMO2 with these analyzers.

2.5.6 System 1 Analyzer

The Panametrics *System 1* is a versatile multi-channel analyzer which accepts inputs from any combination of Panametrics moisture, temperature, oxygen, and thermal conductivity transmitters. See *Figure 74 on page 82* for an interconnection diagram, and refer to the *System 1 User's Manual* (900-019) for details on its operation.

Note: An external 24 VDC power supply (such as the PS5R-C24) is required to use the XMO2 with the *System 1* analyzer.

Chapter 3. Startup & Operation

3.1 Introduction

This chapter provides instructions for starting up and operating the XMO2 system. The following specific topics discussed:

- Powering up the XMO2 transmitter
- Establishing a sample gas flow
- Calibration of the analog output signal

If you have not already done so, read Chapter 2, *Installation*, for details on mounting and wiring the XMO2 transmitter, the sample system, and any other optional equipment.

3.2 Powering Up the XMO2 Transmitter

The XMO2 transmitter does not have a power switch. It begins taking measurements and generating an analog output signal in the 0–25 mA range as soon as it is connected to a 24 VDC power source. To power up the system, simply energize the 24 VDC power supply.

Because the standard XMO2 measurement cell is controlled at a constant 45°C (113°F) operating temperature, allow at least 30 minutes for the unit to warm up and reach temperature stability before taking any measurements. During this time, you can establish a sample gas flow through the system, as described in the next section.

3.3 Establishing a Sample Gas Flow

Usually, the XMO2 transmitter is factory-calibrated at a sample gas flow rate of 1.0 SCFH (500 cc/min) and at atmospheric pressure. Unless otherwise specified on your XMO2 calibration sheet, optional sample system tagging, or optional sample system instructions, your XMO2 should be operated at atmospheric pressure and at the flow rate listed in *Table 4* below.

Table 4: Recommended Sample Gas Flow Rates

XMO2 Type	Flow Rate in SCFH (cc/min)
Weatherproof	1.0 ± 0.5 (500 ± 250)
Explosion-proof	1.0 ± 0.2 (500 ± 100)
Pressure-compensated	0.5 ± 0.5 (250 ± 50)

Note: For optimum performance, operating the XMO2 at conditions other than those used for the factory calibration requires that the unit be recalibrated at the actual field conditions.

To establish a flow of sample gas through the system, complete the following steps (see *Figure 5 on page 10* as an example):

1. Set the sample system ball valves to direct only the sample inlet stream to the inlet port of the XMO2 transmitter.
2. Use the sample inlet needle valve to regulate the flow of sample gas until the flowmeter reads the same flow rate listed for your unit in *Table 4 on page 19*.
3. Read the resulting system pressure on the pressure gauge. Make sure that there are no unnecessary flow restrictions downstream of the sample system.

IMPORTANT: For atmospheric pressure-compensated units, the XMO2 outlet port must be vented directly to atmosphere with no restrictions, by installing all sample system components and tubing upstream of the XMO2 transmitter.

4. Take a reading of the XMO2 4-20 mA analog output.

In some applications, pressure changes due to flow rate changes can cause noticeable errors in the oxygen measurement. In such cases, consider the following corrective measures:

- Reducing the flow rate to the minimum recommended value minimizes flow rate sensitivity. A bypass flow type sample system (speed loop) allows minimum flow through the XMO2 yet maintains a fast transport of the sample gas to the XMO2.
- For the fastest transport, minimize the sample line length from the process.
- If you cannot shorten the sample line length, reduce the sample line pressure to less than 5 psig.

Proceed to the next section to complete the initial XMO2 startup.

3.4 Analog Output Calibration Options

The XMO2 4–20 mA analog output has been calibrated at the factory for the oxygen range indicated on the XMO2 *Calibration Sheet* shipped with the unit. (Figure 9 on page 22 shows a typical calibration sheet.) Upon initial startup, field verification and/or calibration of the 4–20 mA analog output is required. To perform this task, either of the following procedures may be used:

- Pushbutton calibration (offset gas method)
- IDM digital communication calibration (zero/span gas method)

This section provides information on calibrating the XMO2 in the field using either a one-gas (offset gas) method or a two-gas (zero gas and span gas) method. The following specific topics are discussed:

- Factory calibration procedures
- Updating the factory calibration
- Required calibration materials
- Getting the XMO2 ready and locating the calibration switches
- How to perform a one-gas (Offset Gas) or two-gas (Zero and Span Gas) Pushbutton calibration
- How to perform an IDM digital communication calibration

After the XMO2 is in operation, field calibration is recommended at intervals of about 1-3 months, depending on the application.

3.5 Factory Calibration Procedures

Prior to shipment, your XMO2 was calibrated at the factory for the %O₂ range specified at the time of purchase. The following standard %O₂ ranges are available:

- | | | | | |
|-----------|------------|------------|--------------|---------------|
| • 0 to 1% | • 0 to 5% | • 0 to 21% | • 0 to 50%* | • 80 to 100%* |
| • 0 to 2% | • 0 to 10% | • 0 to 25% | • 0 to 100%* | • 90 to 100%* |

* Pressure compensation is required

In addition, your XMO2 was calibrated at the factory for the compensation signal specified at the time of purchase. The following standard compensation signals are provided:

- *Background Gas Compensation* - the standard factory calibration uses N₂ and CO₂ as the background gases.
- *Pressure Compensation* - the standard factory calibration is for atmospheric pressure (700–800 mm of Hg).

Note: *Compensation signals are available for special background gases and/or special pressure ranges. For availability, pricing, and delivery, please contact Panametrics.*

XMO2 Calibration Sheet

XMO2 S/N: 3389
 XMO2 Part Number: XMO2-2H-11
 Calibration Part Number: XCAL-511
 Compensation Type: Background Gas N₂/CO₂
 Calibration Range %O₂: 0 to 21%
 Work Order Number: 501010060853
 Calibration Date: February 15, 2009
 Technician: K. Brin

XMO2 Calibration Data

XMO2 Enable Compensation Yes/Background
 XMO2 System Response Damped
 XMO2 Oxygen Grid 4 Points, 2 Curves
 XMO2 Recorder 4 to 20 mA 0 to 21% O₂

Curve 1: in Nitrogen

PT	%O ₂	O ₂ (mV)	Comp (mV)	O ₂ Output (mA)
1	0.00	-402.9	243.3	4.00
2	10.00	-182.7	243.7	11.62
3	20.00	-3.9	244.1	19.24
4	20.93	13.7	244.2	19.95

Curve 2: in Carbon Dioxide

PT	%O ₂	O ₂ (mV)	Comp (mV)	O ₂ Output (mA)
1	0.00	-390.6	220.6	4.00
2	10.00	-40.5	223.2	11.62
3	20.00	214.0	226.7	19.24
4	20.93	237.7	227.0	19.95

Jumper on P6: Pins Not Used R24 = N/A
Field Calibration: 0% O₂, push CAL button and hold for about 20 seconds

Figure 9: Sample Calibration Sheet

3.6 Enhancing the Factory Calibration

When your XMO2 transmitter was calibrated at the factory, the actual factory calibration data points were entered into the XMO2 software. If requested on the original order, calibration data points for expected field background gas

composition and/or measurement cell pressure variations may also have been entered. To supplement this factory calibration data, calibration data points generated in the field for these parameters can be added into the XMO2 software.

The factory calibration can be further enhanced by performing periodic recalibrations in the field. The XMO2 then uses the new calibration data to create *offset* and *drift curves* that compensate the original factory calibration data for variations that occur in the field.

When making a measurement, the XMO2 uses the *Offset Curve* or *Drift Curve*, along with any background gas and/or cell pressure compensation data, entered at the factory or in the field, to update the factory calibration data.

To maintain the integrity of this process, the XMO2 should be recalibrated periodically. This is typically done every 1-3 months with a single (offset) calibration gas, depending on the application. The optimum recalibration interval depends on such factors as %O₂ range, required accuracy, components of the gas mixture, the cleanliness of the sample gas, etc. In addition, the XMO2 should be recalibrated with the two-gas (zero gas and span gas) method at least once per year. Again, the optimum calibration interval depends on the specific application.

Using the calibration procedures in this chapter, the XMO2 can be recalibrated for the same %O₂ range, background gas mixture, and compensation signals used for the factory calibration. However, if it has been some time since the original factory calibration, or if you want to calibrate the XMO2 for a different %O₂ range, gas mixture, or compensation signal, contact the factory for instructions.



CAUTION! The calibration procedures described in this chapter require the use of specialized apparatus and should be performed only by properly trained service personnel, following all applicable safety practices.

3.7 Required Calibration Materials

To perform a field calibration, the following materials are required:

- Offset gas - for a one-gas %O₂ calibration
- Zero gas - for a two-gas %O₂ calibration and/or a 4-20 mA analog output calibration
- Span gas - for a two-gas %O₂ calibration and/or a 4-20 mA analog output calibration

Note: *Suggestions for suitable calibration gases are listed on the XMO2 Calibration Sheet provided with your unit. Also, the accuracy of the calibration will only be as good as the accuracy of the calibration gas(es) used.*

- Panametrics XMO2 Calibration Sheet
- A *sample system* or individual components (e.g., flowmeter, needle valve, pressure gauge, etc.) for introducing the calibration gas(es) to the XMO2 transmitter at the required pressure and flow rate. See Chapter 2, *Installation*, for specific recommendations.
- A multimeter or ammeter (for a 4-20 mA analog output calibration)



WARNING! Avoid using explosive gas mixtures as your XMO2 calibration gases.

3.8 Preparing for Field Calibration

To prepare the XMO2 for a field calibration, refer to *Figure 10 on page 25* and perform the following preliminary steps:

1. Turn the power on and allow at least 30 minutes for the XMO2 to reach temperature stability.
2. Loosen the set screw that locks the XMO2 cover in place, and unscrew the cover.

IMPORTANT: Remember to replace the cover after the field calibration has been completed.

3. Refer to *Figure 11 on page 25*, and locate the following items:
 - Calibration pushbutton (Switch S3)
 - Zero/span selector (Switch S1)
 - Terminal block TBI

Note: *If you plan to perform the field calibration at a computer terminal via the XMO2 RS232 digital output, you do not need to access the above items because you will skip steps 1-2 above.*

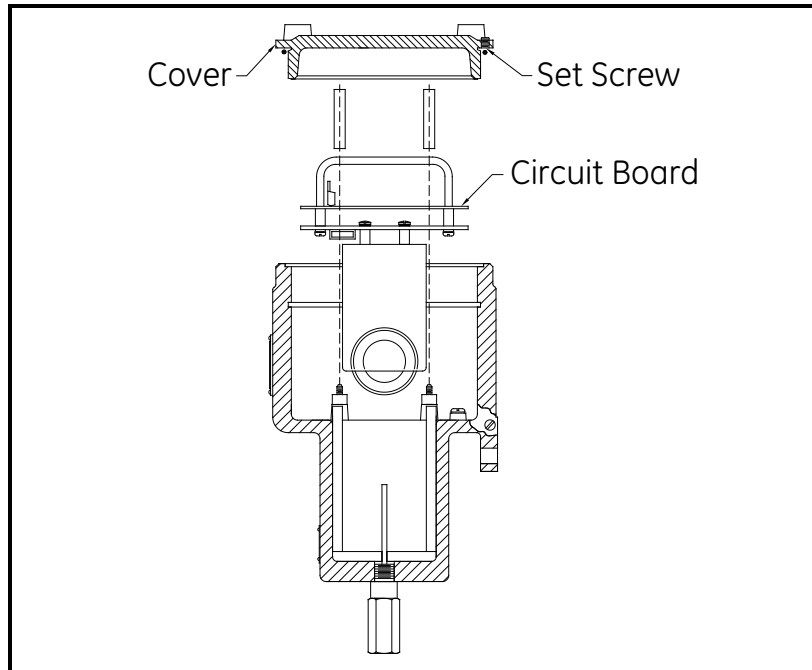

Figure 10: XMO2 Cover, Set Screw, and PCB

Note: The XMO2 digital PCB (see Figure 11 below) is located directly below the cover (see Figure 10 above).

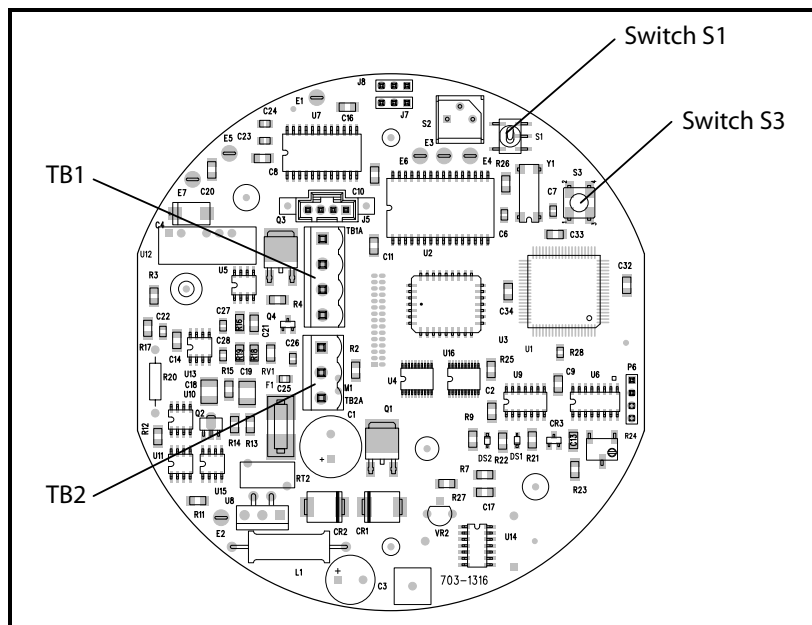

Figure 11: PCB Calibration Switches



CAUTION! Switch S2, jumper P6, potentiometer R24, and potentiometer R25 are also located on the XMO2 circuit boards. However, these items are not used for normal field calibration. Never touch these items unless specifically instructed to do so by Panametrics.

3.9 One-Gas Pushbutton Field Calibration

This simplified field calibration procedure uses a single (offset) gas to recalibrate the XMO2. Then, the XMO2 compares the data from this field recalibration to the original factory calibration data, and stores the difference as an *Offset Curve*.

The XMO2 is usually factory-programmed for the offset gas pushbutton calibration method. The *Calibration Sheet* shipped with your unit specifies the recommended oxygen level (in %O₂) for the offset gas to be used. This is the same offset gas oxygen level that was used for the factory calibration. If no offset gas %O₂ is specified on the XMO2 *Calibration Sheet*, the factory calibration was done with 100% N₂ (0.00 %O₂) and the field calibration should use the same offset gas.

To perform a pushbutton offset gas field calibration, complete the following steps:

1. Verify that your XMO2 is configured for a one-gas calibration. This is the factory default configuration for all units.
2. Using the sample system controls, stop the flow of sample gas to the XMO2 inlet port and initiate a flow of the same offset gas specified on the XMO2 Calibration Sheet. Establish the same flow rate and pressure conditions used for the sample gas, and allow the offset gas to flow through the XMO2 for at least three minutes.
3. Using *Figure 11 on page 25* as a guide, locate the *Calibration Pushbutton* (Switch S3). Depress the *Calibration Pushbutton* and hold it down for 20 seconds. During this time, the green light below the *Calibration Pushbutton* will go out.
4. When the *Calibration Push Button* is released, the green light will come back on and the XMO2 has been recalibrated.

You may now return the XMO2 to normal operation by using the sample system controls to stop the offset gas flow and restart the flow of sample gas.

3.10 Two-Gas Pushbutton Field Calibration

This simplified field calibration procedure uses two (zero and span) gases to recalibrate the XMO2. Then, the XMO2 compares the data from this field recalibration to the original factory calibration data, and stores the difference as a *Drift Curve*.

Note: *If the range of your XMO2 is 0 to 21% O₂, you can use air as the span gas.*

3.10.1 Setup

Before proceeding, you must be sure that your XMO2 is configured for a two-gas calibration. The required reprogramming must be done via the IDM communication link, as follows:

1. Launch IDM.
2. From the Instrument window, pull down the *Edit Functions* menu, as shown in *Figure 12 on page 30*.
3. Click on the *Field Cal* option. In the *Field Cal* window (shown in *Figure 13 on page 31*), click on the *Configure Cal* button.
4. In the *Configure Cal* window (shown in *Figure 17 on page 33*), click on the *Field Cal Type* button.
5. In the *Field Cal Type* window (shown in *Figure 18 on page 33*), click on either the 1-Point or 2-Point button. Then, click on any button on the right to return to the *Configure Cal* window.

Note: *The zero and span calibrations can be performed in either order. For zero-based calibration ranges (e.g., 0-25%), we recommend performing the span calibration first. For non-zero-based calibration ranges (e.g., 90-100%), we recommend performing the zero calibration first.*

Proceed to the appropriate section to begin the field calibration.

3.10.2 Zero Gas Pushbutton Calibration

To perform a zero gas pushbutton field calibration, complete the following steps:

1. Using the sample system controls, stop the flow of sample gas to the XMO2 inlet port and initiate a flow of the same zero gas specified on the XMO2 Calibration Sheet. Establish the same flow rate and pressure conditions used for the sample gas, and allow the zero gas to flow through the XMO2 for at least three minutes.
2. Using *Figure 11 on page 25* as a guide, locate the *Zero/Span Selector* (Switch S1). Set the *Zero/Span Selector* (Switch S1) to position "1" ("Zero").
3. Using *Figure 11 on page 25* as a guide, locate the *Calibration Pushbutton* (Switch S3). Depress the *Calibration Pushbutton* and hold it down for 20 seconds. During this time, the green light below the *Calibration Pushbutton* will go out.
4. When the *Calibration Pushbutton* is released, the green light will come back on and the XMO2 has been recalibrated. Verify that the mA reading on the ammeter is now equal to the expected value.

IMPORTANT: If the XMO2 fails to recalibrate to the correct analog output value, contact Panametrics for assistance.

3.10.3 Span Gas Pushbutton Calibration

To perform a span gas pushbutton field calibration, complete the following steps:

1. Using the sample system controls, stop the flow of sample gas to the XMO2 inlet port and initiate a flow of the same span gas specified on the XMO2 Calibration Sheet. Establish the same flow rate and pressure conditions used for the sample gas, and allow the span gas to flow through the XMO2 for at least three minutes.
2. Using *Figure 11 on page 25* as a guide, locate the *Zero/Span Selector* (Switch S1). Set the *Zero/Span Selector* (Switch S1) to position "3" ("Span").
3. Using *Figure 11 on page 25* as a guide, locate the *Calibration Pushbutton* (Switch S3). Depress the *Calibration Pushbutton* and hold it down for 20 seconds. During this time, the green light below the *Calibration Pushbutton* will go out.
4. When the *Calibration Pushbutton* is released, the green light will come back on and the XMO2 has been recalibrated.

You may now return the XMO2 to normal operation by using the sample system controls to stop the span gas flow and restart the flow of sample gas.

3.11 IDM Digital Communication Calibration

At the initial startup of the XMO2, *IDM Digital Communication Calibration* is the second method available for field verification/calibration of the 4-20 mA analog output.

Note: *IDM can also be used to change the 4-20 mA analog output range. See the next section for details.*

To prepare for this calibration method, refer to *Figure 10 on page 25* and perform the following preliminary steps:

1. Make sure that the RS232 digital output of the XMO2 has been connected to a computer or terminal in accordance with the instructions given in Chapter 2, *Installation*.
2. Loosen the set screw that locks the XMO2 cover in place, and unscrew the cover.

IMPORTANT: Remember to replace the cover after the calibration has been completed.

3. Turn the computer or terminal on and launch IDM.

Note: *Be sure you have properly installed Instrument Data Manager on your PC before attempting to program the XMO2.*

3.12 The Edit Functions Menu

To access the XMO2 calibration, pull down the *Edit Functions* menu from the Instrument window. This menu consists of the five commands displayed in *Figure 12* below. To access any of the commands, simply select it from the menu.

Note: As a programming aid, the relevant portions of the Edit Functions menu have been mapped in *Figure 75* on page 85 and *Figure 76* on page 86.

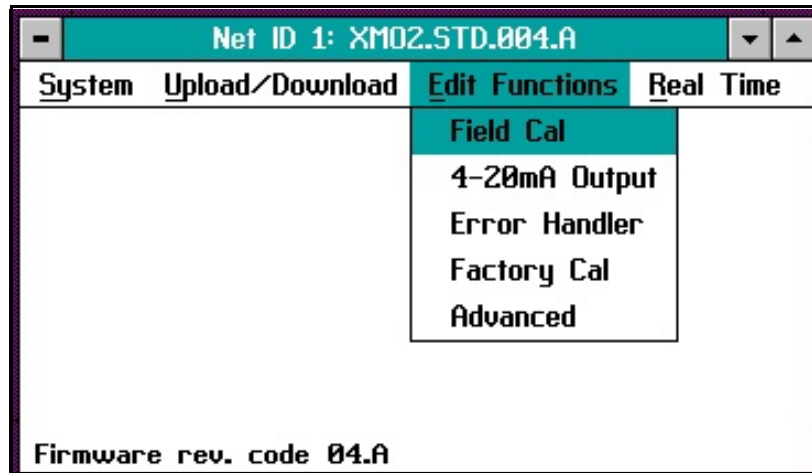

Figure 12: Edit Functions Menu

The following three buttons appear at the right of all menu windows (see *Figure 13* on page 31):

- *Previous Item* - returns you to the previous window (either the command menu or the previous parameter entered).
- *Next Item/Enter* - confirms the selection or data entered, and either opens the next window or returns you to the command menu (depending on your position in the program).
- *Exit Page* - returns you to the command menu.

3.13 The *Field Cal* Menu

When you select the *Field Cal* option, a window similar to the one in *Figure 13* below opens.

IMPORTANT: The instructions in this section assume that the factory-programmed 2-Gas calibration method is still selected. If you have previously changed this to the 1-Gas calibration method, any windows that show Zero and Span calibration gas buttons are replaced with a window that shows just the single Offset calibration gas button.

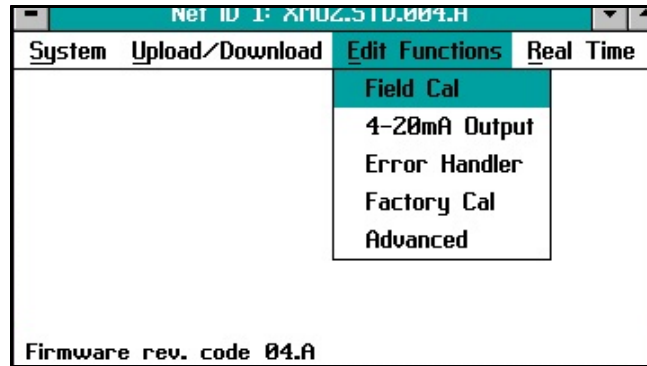

Figure 13: *Field Cal* Window

The *Field Cal* option offers the following five choices:

- *Perform Cal* - calibrates the XMO2
- *Configure Cal* - sets the calibration type and parameters
- *Calibration Drifts* - lists drift percentages for zero and span gases
- *Clear Calibration* - clears the last calibration
- *Hold Last Value* - holds the last value calibrated

Note: Clicking on the Next Item/Enter button selects the option listed on the status line above the option buttons (*Perform Cal* in *Figure 13* above). The option listed on the status line in any window is the option that was chosen the last time that menu was used.

Clicking on any of the above choices opens a new window that allows you to perform that function. Proceed to the appropriate section for a detailed description of each option.

3.13.1 Perform Cal

Clicking on the *Perform Cal* button opens a window similar to *Figure 14* below.

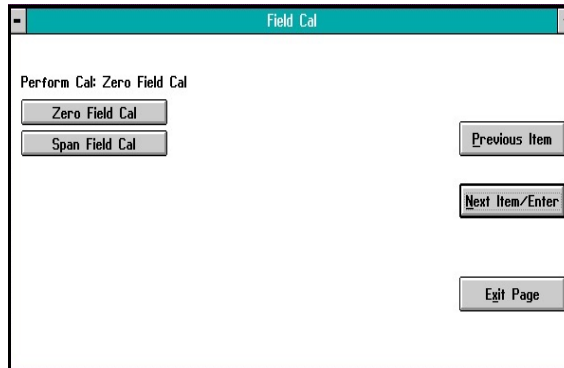

Figure 14: Perform Cal Window

Click on the *Zero Field Cal* button to calibrate the zero point or on the *Span Field Cal* button to calibrate the span point. In either case, a window similar to *Figure 15* below opens.

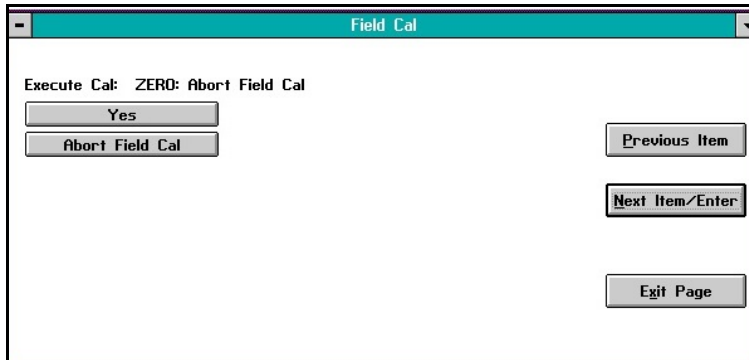

Figure 15: Zero Cal Window

Click *Yes* to perform the calibration, or *Abort Field Cal* to stop the calibration and return to the previous menu. The result of a completed calibration is shown in *Figure 16* below.

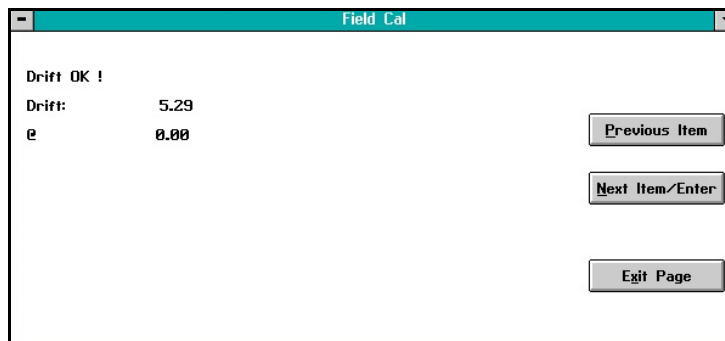

Figure 16: Zero Cal Results

Click on *Previous Item* or on *Next Item/Enter* to return to the previous window, or on *Exit Page* to return to the Instrument Menu.

3.13.2 Configure Cal

The *Configure Cal* option enables you to change the field calibration type and various calibration parameters. Clicking on the *Configure Cal* button opens a window like that shown in *Figure 17* below.

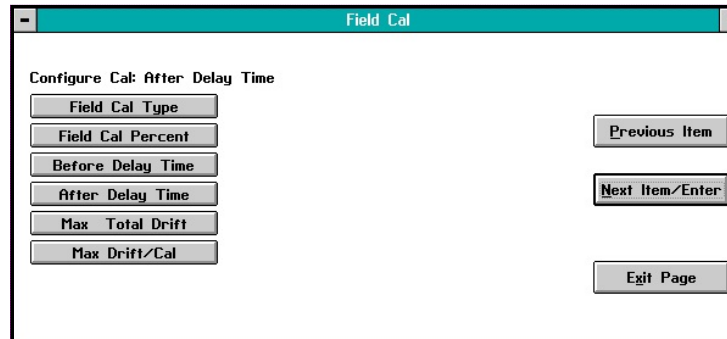

Figure 17: *Configure Cal* Window

Click on the desired option button and proceed to the appropriate section for a discussion of that option.

3.13.2.1 Field Cal Type

A typical *Field Cal Type* window is shown in *Figure 18* below.

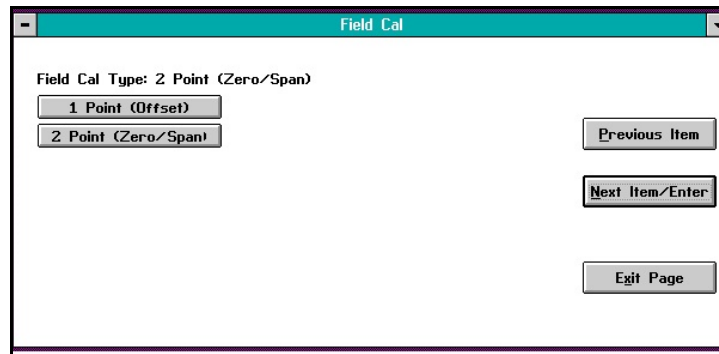

Figure 18: *Field Cal Type* Window

IMPORTANT: The factory setting is the 2 Point (Zero/Span) calibration type.

Click on the appropriate button to select the desired calibration type. Then, click on any button on the right to return to the *Configure Cal* window.

3.13.2.2 Field Cal Percent

A typical *Field Cal Percent* window is shown in *Figure 19* below.

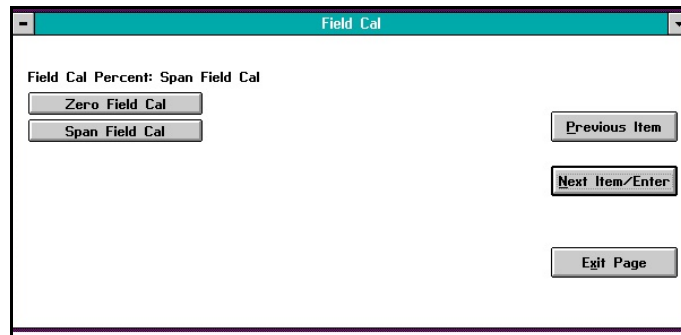

Figure 19: Field Cal Percent Window

The above menu is used to specify the oxygen percentages of the zero and span calibration gases that will be used. The recommended gases are listed on the XMO2 Calibration Data Sheet.

Click on the *Zero Field Cal* button to enter the percentage of oxygen in your zero gas. A window similar to *Figure 20* below opens.

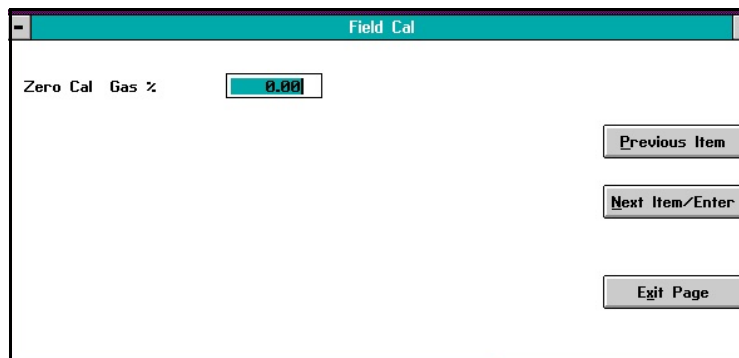

Figure 20: %O2 Entry Window

Type the zero gas oxygen percentage in the text box, and click the *Next Item/Enter* button to confirm the entry (click *Previous Item* or *Exit Page* button to leave the window without changing the existing percentage).

IMPORTANT: The factory setting is for a 0.00% zero gas and a 20.93% span gas (air).

Repeat the above procedure to enter your span calibration gas oxygen percentage. Then, click on any button on the right to return to the *Configure Cal* window.

3.13.2.3 Before Delay Time

Clicking on the *Before Delay Time* button opens a window similar to *Figure 21* below.

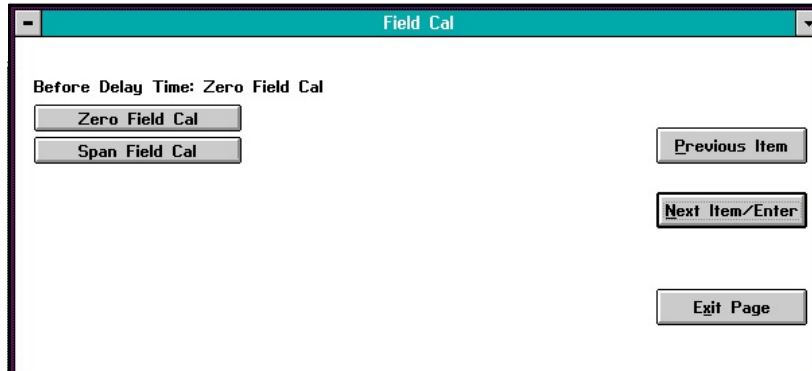

Figure 21: Before Delay Time Window

In the above window, click on the *Zero Field Cal* button to enter the before delay time for the zero calibration point. A window similar to *Figure 22* below opens.



Figure 22: Zero Point Delay Time Window

Enter the desired zero point before delay time, in minutes and seconds, in the text box. Then, click on the *Next Item/Enter* button to confirm the entry (click the *Previous Item* or *Exit Page* button to exit the window without changing the existing value).

Repeat the above procedure to enter the before delay time for the span point.

3.13.2.4 After Delay Time

Repeat the procedure in the above section to set the *after delay time* for both the zero and span points.

3.13.2.5 Max Total Drift

Max Total Drift is the maximum total calibration drift allowable, expressed as a percentage of the full-scale reading. Selecting this option opens a window similar to *Figure 23* below.

Figure 23: Max Total Drift Entry Window

Enter the desired percentage of the full-scale reading in the text box, and click the *Next Item/Enter* button to confirm the entry (click the *Previous Item* or *Exit Page* button to leave the window without changing the existing percentage).

3.13.2.6 Max Drift/Cal

Max Drift/Cal is the maximum calibration drift allowable per calibration, expressed as a percentage of the full-scale reading. To enter a value, repeat the procedures in the above section.

3.13.3 Calibration Drifts

The *Calibration Drifts* option enables you to view the current calibration drift at both the zero and span points since the last calibration was performed. Clicking on this button opens a window similar to *Figure 24* below.

Figure 24: Calibration Drifts Window

Click on any button to return to the main *Field Cal* window.

3.13.4 Clear Calibration

The window for the *Clear Calibration* option is similar to *Figure 25* below.

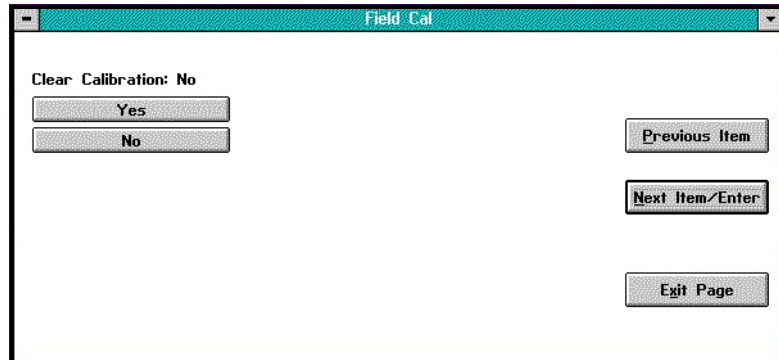

Figure 25: Clear Calibration Window

Click on the *Yes* button to clear the most recent calibration, or click on the *No*, *Previous Item* or *Exit Page* button to close the window without clearing the most recent calibration. If you click on the *Yes* button, a confirmation screen similar to *Figure 26* below opens.

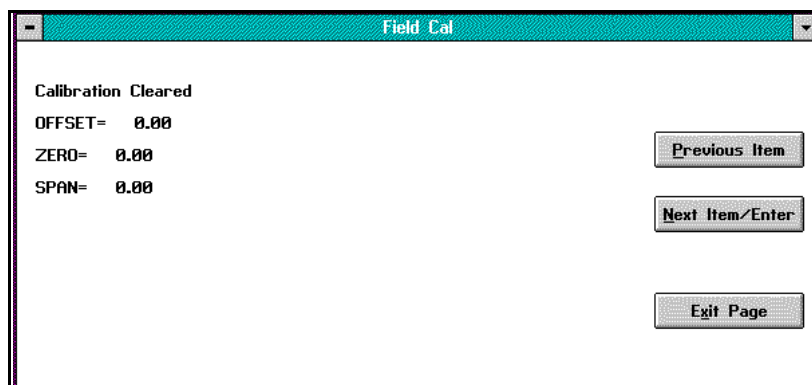

Figure 26: A Typical Cleared Calibration

Click on the *Previous Item* button to return to the *Clear Calibration* window, or click on the *Next Item/Enter* or *Exit Page* button to return to the main *Field Cal* window.

3.13.5 Hold Last Value

In addition to performing a field calibration or configuring the calibration parameters, you can program the XMO2 to hold the last calibrated value. To perform this task, click on the *Hold Last Value* button. You will notice that the text on the button now reads *Disable Hold Last*. To cancel the *Hold Last Value* programming, just click on this new button. You can toggle between the two states for this parameter by clicking on this button (remember that the current state is the one NOT written on the button).

3.14 Changing the 4-20 mA Analog Output Range

The XMO2 *Calibration Sheet* shipped with the unit lists the 4-20 mA analog output range that was set at the factory. IDM enables you to change this range via the *4-20mA Output* option. After you click on the *4-20mA Output* button from the *Edit Functions* menu (Figure 12 on page 30), a window similar to Figure 27 below opens. Clicking on any option opens the window for that option, while clicking on *Next Item/Enter* opens the menu listed on the status line above the options.

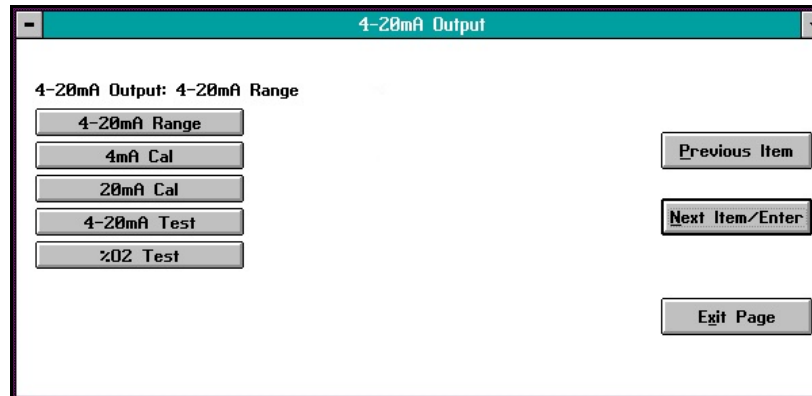

Figure 27: 4-20 mA Output Window

The *4-20mA Output* option offers the following five choices:

- *4-20mA Range* - specifies the oxygen percentage for both the 4 mA and 20 mA analog output points
- *4mA Cal* - calibrates the 4 mA point
- *20mA Cal* - calibrates the 20 mA point
- *4-20mA Test* - tests the analog output at various percent oxygen points
- *%O2 Test* - tests the analog output at various percent oxygen points

Note: Clicking on the *Next Item/Enter* button selects the option listed on the status line above the option buttons (*4-20mA Range* in Figure 27 above). The option listed on the status line in any window is the option that was chosen the last time that menu was used.

Clicking on any of the above choices opens a new window that allows you to perform that function. Proceed to the appropriate section for a detailed description of each option.

3.14.1 4–20mA Range

Selecting the 4–20mA Range option opens a window similar to *Figure 28* below.

The screenshot shows a window titled "4-20mA Output". Inside, there is a label "%O2 for 4mA Output" followed by a text input box containing the value "0.00". To the right of the input box are three buttons: "Previous Item", "Next Item/Enter", and "Exit Page".

Figure 28: 4 mA Output %O2 Window

In the text box, enter the oxygen percentage in the sample gas that should generate an analog output of 4 mA. Then, click on the *Next Item/Enter* button to confirm the entry (click the *Previous Item* or *Exit Page* button to exit the window without changing the existing value) and open a window similar to *Figure 29* below.

The screenshot shows a window titled "4-20mA Output". Inside, there are two labels with corresponding text input boxes. The first label is "%O2 for 4mA Output" with a value of "0.00". The second label is "%O2 for 20mA Output" with a value of "21.00". To the right of the input boxes are three buttons: "Previous Item", "Next Item/Enter", and "Exit Page".

Figure 29: 20 mA Output %O2 Window

In the text box, enter the oxygen percentage in the sample gas that should generate an analog output of 20 mA. Then, click on the *Next Item/Enter* button to confirm the entry (click the *Previous Item* or *Exit Page* button to exit the window without changing the existing value).

The next window requires you to either *Clamp 4–20mA Output* or not. Select either *No* or *Yes* from the list box and click on the *Next Item/Enter* button to confirm the entry (click the *Previous Item* or *Exit Page* button to exit the window without changing the existing value).

Note: A clamped output cannot display measurements outside the programmed 4–20 mA analog output range, while a reading that is not clamped can display measurements outside the programmed range.

3.14.2 4mA Cal

Click on the *4mA Cal* button to open a window similar to *Figure 30* below and force the analog output to exactly 4.00 mA. This allows you to calibrate the 4 mA point of the analog output signal.

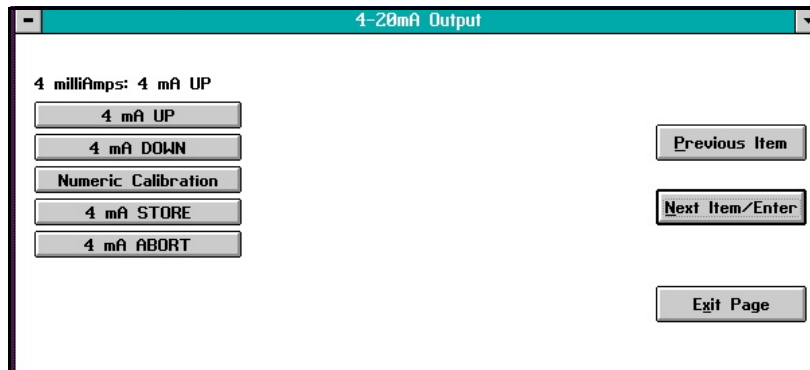

Figure 30: 4mA Cal Window

Use an ammeter connected to the analog output terminals on the rear panel to monitor the 4-20 mA output signal. Calibrate the 4 mA point by clicking on the *UP* and/or *DOWN* buttons until the ammeter reads exactly 4.00 mA. Alternatively, you can click on the *Numeric Calibration* button to open a window like *Figure 31* below.

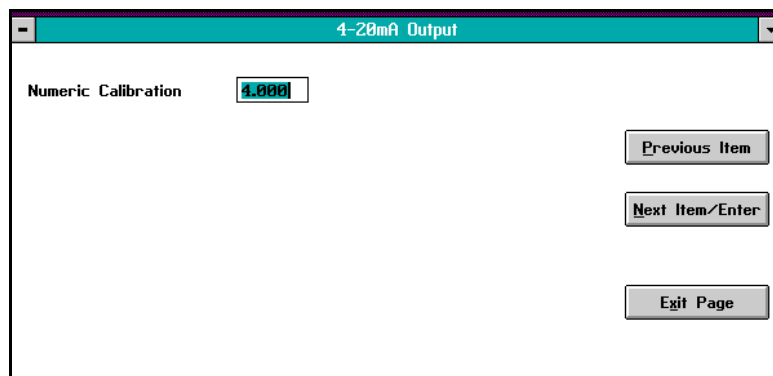

Figure 31: Numeric Calibration Window

Enter the desired current reading (4.00) in the text box and click on the *Next Item/Enter* button (click on the *Previous Item* or *Exit Page* button to close the window without changing the value).

After you have calibrated the 4 mA signal, click on the *4mA STORE* button to save the calibration. However, if the calibration is not satisfactory, click on the *4mA ABORT* button to cancel the calibration.

3.14.3 20 mA Cal

Repeat the instructions in the section above to calibrate the 20 mA point of the analog output signal.

3.14.4 4-20mA Test

Selecting the *4-20mA Test* option opens a window similar to *Figure 32* below.

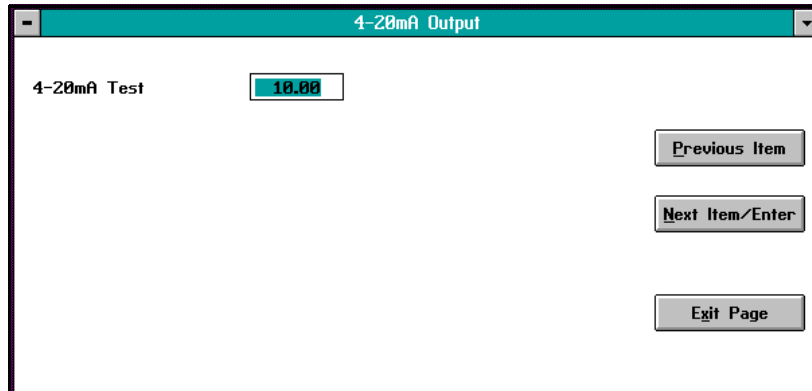

Figure 32: 4-20mA Test Window

Enter a current value in the 4-20 mA range to force the analog output signal to that value. Click on the *Next Item/Enter* button and verify that the ammeter connected to the output terminals on the rear panel reads the correct value. You may repeat this procedure as many times as desired to test the output at various points in the 4-20 mA range. When you have finished, click the *Exit Page* button to close the window.

3.14.5 %O2 Test

Selecting the *%O2 Test* option opens a window similar to *Figure 33* below.

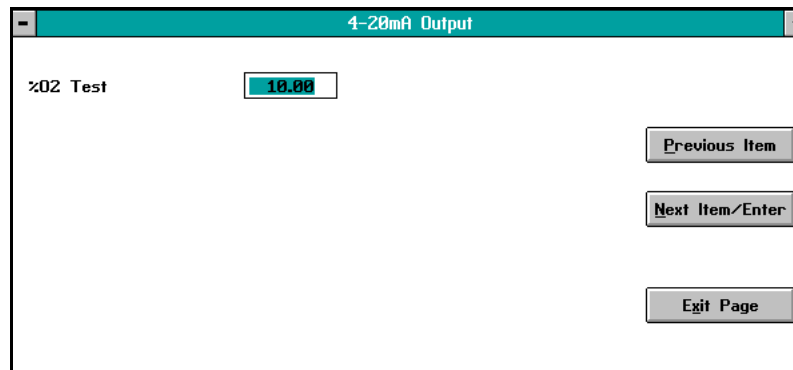

Figure 33: %O2 Test Window

Enter an oxygen percentage in the text box. Click on the *Next Item/Enter* button and verify that the digital display on the front panel reads the correct value. You may repeat this procedure as many times as desired to test the display reading at various oxygen percentages. When you have finished, click the *Exit Page* button to close the window.

Chapter 4. Programming with Instrument Data Manager

4.1 Introduction

The XMO2 is factory-programmed and ready for immediate use. However, you can access its programming with your PC, using the Panametrics *Instrument Data Manager* (IDM) software. IDM also allows you to upload or download site files, display data, and log and view real-time data and diagnostic data in numeric, bar chart or line chart formats. For further information on the display and logging functions, refer to the *Instrument Data Manager User's Manual* (910-185). Since Chapter 3, *Startup & Operation*, describes the *Field Cal* and *4-20 mA Output* options, this chapter covers the *Error Handler*, *Factory Cal* and *Advanced* options in the *Edit Functions* menu.

Note: Note: Be sure you have properly installed *Instrument Data Manager* on your PC before attempting to program the XMO2.

4.2 The Edit Functions Menu

To access the XMO2 calibration, pull down the *Edit Functions* menu from the Instrument window. The menu consists of the five commands displayed in *Figure 34* below. To access any of the commands, simply select it from the menu.

Note: Note: As a programming aid, the relevant portions of the *Edit Functions* menu have been mapped in *Appendix C*.

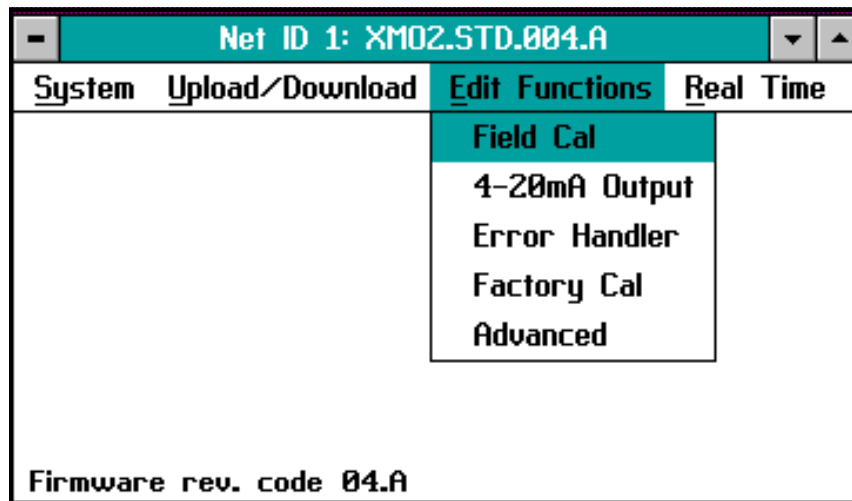

Figure 34: Edit Functions Menu

The following three buttons appear at the right of all menu windows (see *Figure 35* on page 44):

- *Previous Item* - returns you to the previous window (either the command menu or the previous parameter entered).
- *Next Item/Enter* - confirms the selection or data entered, and either opens the next window or returns you to the command menu (depending on your position in the program).
- *Exit Page* - returns you to the command menu.

4.2.1 The Error Handler Menu

Note: Note: For information on the *Field Cal* and *4-20 mA Output* options, refer to Chapter 3.

The *Error Handler* menu allows you to configure the manner in which the XMO2 responds to various error conditions. When you click on the *Error Handler* button in the *Edit Functions* menu (*Figure 34* on page 43), a window similar to *Figure 35* below opens.

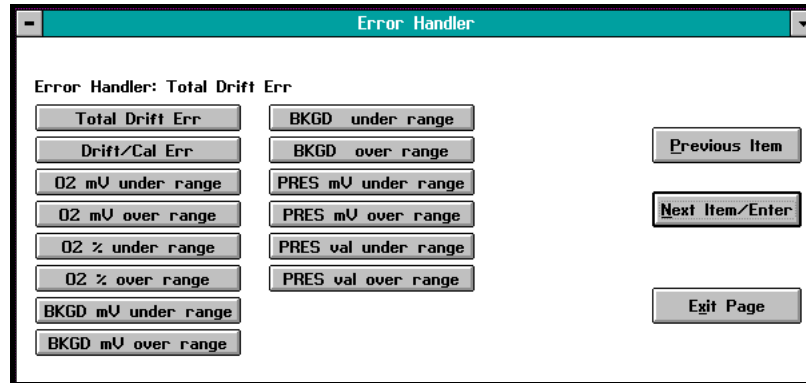

Figure 35: Error Handler Window

There is a button in the above window for each of the following error conditions:

- Total Drift Err
- Drift/Cal Err
- O2 mV under range
- O2 mV over range
- O2 % under range
- O2 % over range
- BKGD mV under range
- BKGD mV over range
- BKGD under range
- BKGD over range
- PRES mV under range
- PRES mV over range
- PRES val under range
- PRES val over range

To configure the XMO2's response to any of the above error conditions, click on the corresponding button in the window above and proceed to the appropriate section for instructions.

4.2.2 4.2.2 Total Drift Error

The *Total Drift Error* option lets you enable or disable error handling for a total calibration drift error and to specify the mA output that will be generated during an error condition (typically 23 mA). Clicking on this button opens a window similar to *Figure 36* below.

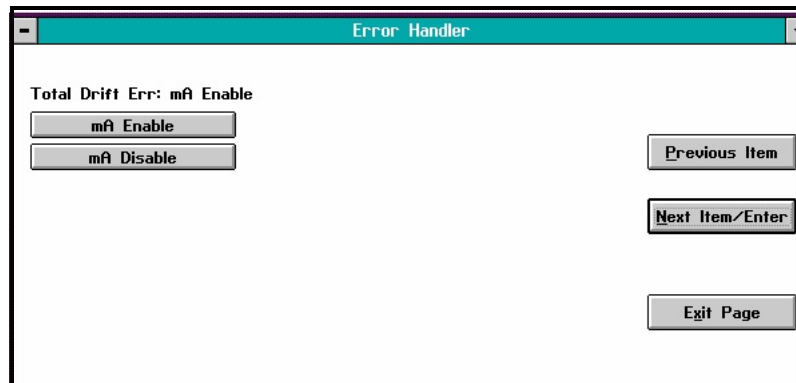
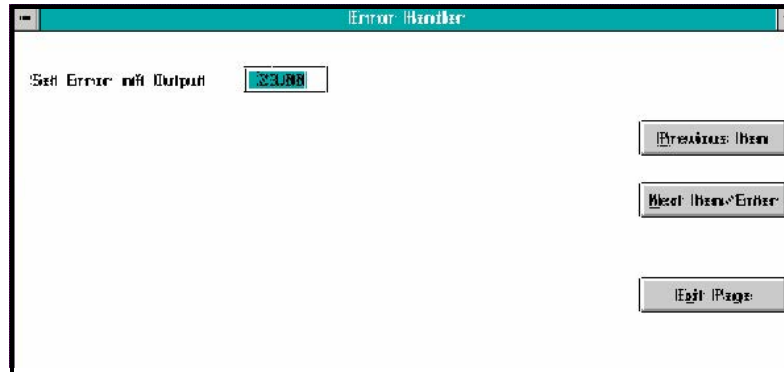

Figure 36: Total Drift Error mA Window

Click on the appropriate button to either *enable* or *disable* error handling for this condition at the XMO2's analog output. If you clicked on the *mA Disable* button, skip the next screen. If you clicked on *mA Enable*, a window similar to *Figure 37* below opens.

**Figure 37: Error mA Output Entry Window**

In the text box at the above screen, enter the mA output that you wish to have generated in the event of a total calibration drift error. Click on the *Next Item/Enter* button to confirm the entry.

After specifying the analog output response to this error condition, a window similar to *Figure 38* below opens.

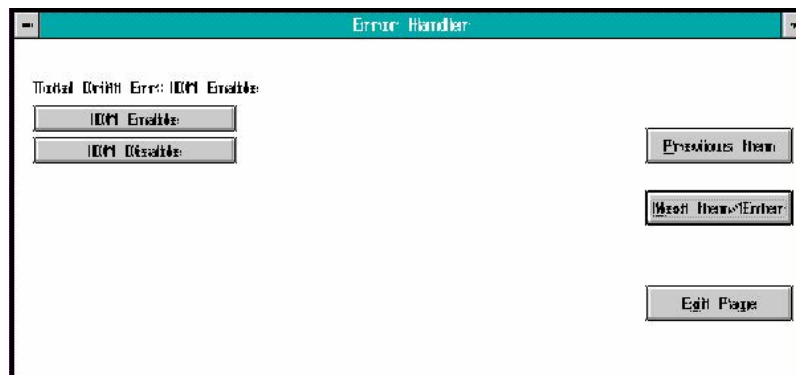
**Figure 38: Total Drift Error IDM Window**

Click on the appropriate button to either *enable* or *disable* the generation of an error signal for this condition via the XMO2's IDM link. In either case, you will be returned immediately to the main *Error Handler* menu.

4.2.3 All Other Error Conditions

The programming for all of the other XMO2 error conditions listed on *page 44* is identical to that described in the previous section for the *Total Drift Err* condition. Therefore, simply refer to the instructions in the previous section to configure the error handling for any of these other conditions. All three windows will be identical to those shown in the previous section, except that the error listed above the *Enable/Disable* buttons will reflect the specific error currently being programmed.

4.3 The Factory Cal Menu

The XMO2 comes from the factory completely programmed for your particular application. Should it become necessary to restore the factory setup, you can use the *Factory Cal* menu and your *Calibration Data Sheet* to reenter the factory data.

CAUTION! Always refer to your *Calibration Data Sheet* for the data to enter in the *Factory Cal* menu. Entering incorrect data will result in inaccurate operation of the XMO2.

4.3.1 Background Gas Labels

From the *Edit Functions* menu (shown in *Figure 34* on page 43), click on the *Factory Cal* button. A screen similar to *Figure 39* below opens.

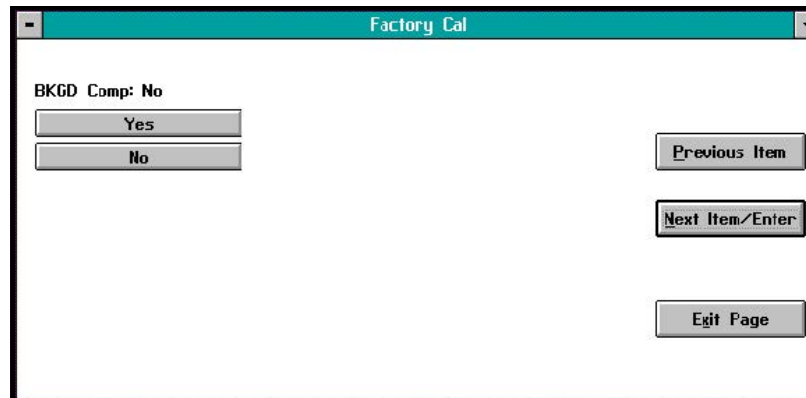

Figure 39: BKGD Comp Window

Note: Note: If background gas compensation is not required for your XMO2, click on the No button in the above window and proceed directly to the Pressure Compensation section on the next page.

To enter your background gas labels click on the Yes button above. A window similar to *Figure 40* below opens.

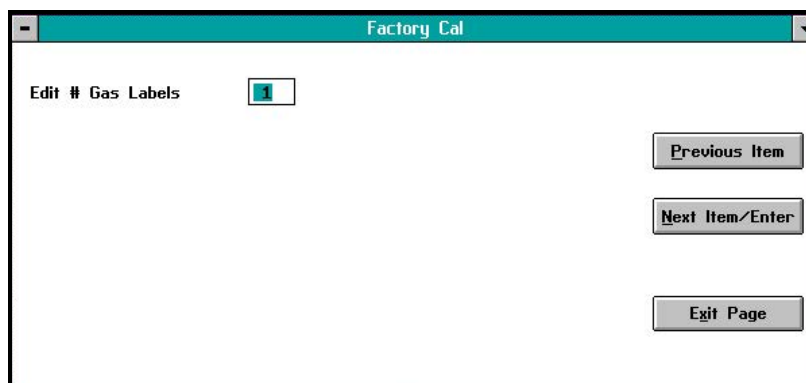

Figure 40: Edit # Gases Window

CAUTION! CAUTION! Always refer to your *Calibration Data Sheet* for the data to enter in the *Factory Cal* menu.

Entering incorrect data will result in inaccurate operation of the XMO2.

In *Figure 40* on page 47, enter the number of background gases for which you have compensation data. Then, press the *Next Item/Enter* button to open a window similar to *Figure 41* below.

Edit # Gas Labels	Gas# 1
1	Background Label 1

Buttons: Previous Item, Next Item/Enter, Exit Page

Figure 41: Point Editing Window

In the above window, enter an identifying label for background gas #1, and click on the *Next Item/Enter* button. The above sequence will repeat until you have entered identifying labels for each of your background gases.

4.3.2 Pressure Compensation

If you did not enter any background gas labels or upon entering your final background gas label, a window similar to Figure 42 below opens.

Pressure Comp: No

Buttons: Yes, No, Previous Item, Next Item/Enter, Exit Page

Figure 42: Pressure Comp Window

Note: Note: If pressure compensation is not required for your XMO2, click on the No button in the above window and proceed directly to the Entering Data Points section on page 51.

4.3.2.1 Number of Pressures

When you click on the Yes button in Figure 42 on page 48, a window similar to Figure 43 below opens.

Pressure Index: Edit # of Pressures

Buttons: Edit # of Pressures, PRS1, PRS2, Previous Item, Next Item/Enter, Exit Page

Figure 43: Edit # Pressures Window

To enter your pressure compensation data (be sure to reference your *Calibration Data Sheet*) click on the *Edit # of Pressures* button above to open a window similar to *Figure 44* below.

The screenshot shows a window titled "Factory Cal". Inside the window, there is a label "Edit # of Pressures" followed by a small input box containing the number "2". To the right of the input box are three buttons stacked vertically: "Previous Item", "Next Item/Enter", and "Exit Page".

Figure 44: Edit # Pressures Window

In *Figure 44* above, enter the number of pressures for which you have compensation data. Then, press the *Next Item/Enter* button to return to the window in *Figure 43* above.

4.3.2.2 Pressure #1 Background Gases

Note: Note: If you are not using background gas compensation, this menu does not appear. Proceed directly to the next section.

To begin entering your data points for each of the pressure compensation curves, click on the *PRS1* button in *Figure 43* on page 49 to open a window similar to *Figure 45* below.

The screenshot shows a window titled "Factory Cal". Inside the window, there is a label "BK Indx PRS1: Edit # of BKGDs". Below this label are three buttons stacked vertically: "Edit # of BKGDs", "Background Label 1", and "Background Label 2". To the right of these buttons are three buttons stacked vertically: "Previous Item", "Next Item/Enter", and "Exit Page".

Figure 45: Background Gas Window

In the above window, click on the *Edit # of BKGDs* button to open a window similar to *Figure 46* below.

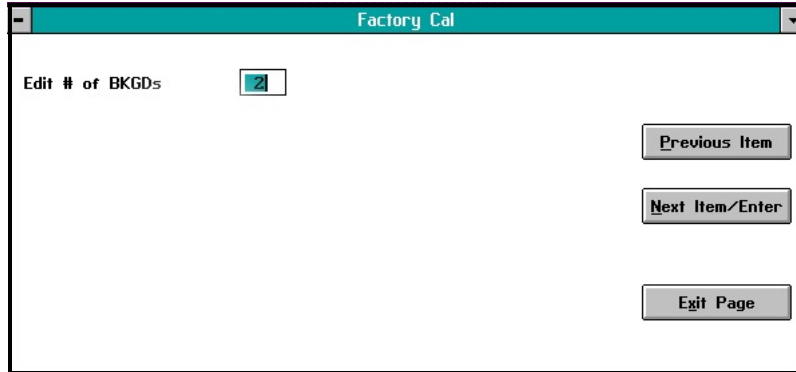

Figure 46: Edit # of BKGDs Window

In the above window, enter the number of background gases for which you have compensation data at the first compensated pressure. Then, click on the *Next Item/Enter* button to confirm your entry and return to the window in Figure 45 above.

Entering Data Points

In the window shown in Figure 45 on page 50, click on the *Background Label 1* button (the actual text on this button will correspond to the label you entered in the previous section) to open a window similar to Figure 47 below.

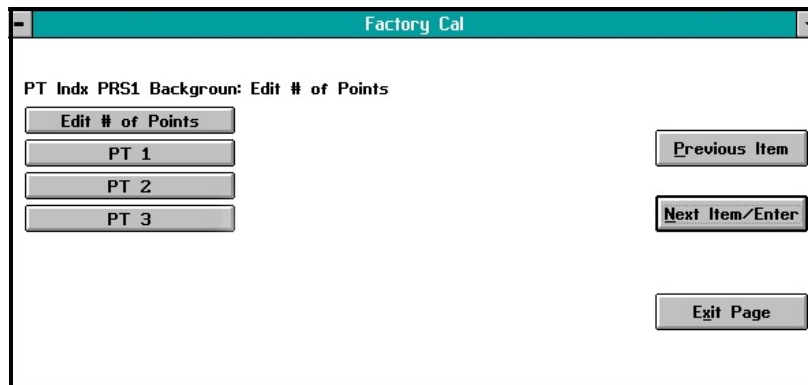

Figure 47: PRS1 BKGD Points Window

In the above window, click on the *Edit # of Points* button to open a window similar to Figure 48 below.

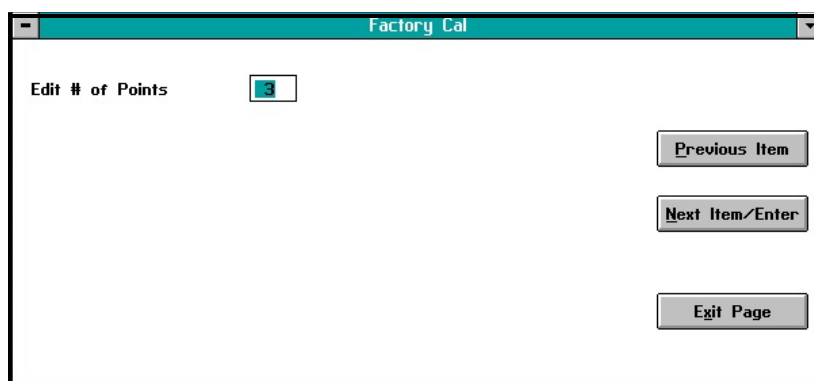

Figure 48: PRS1 BKGD Points Window

To begin entering your data, click on the *PT 1* button in *Figure 47* above to open a window similar to *Figure 49* below.

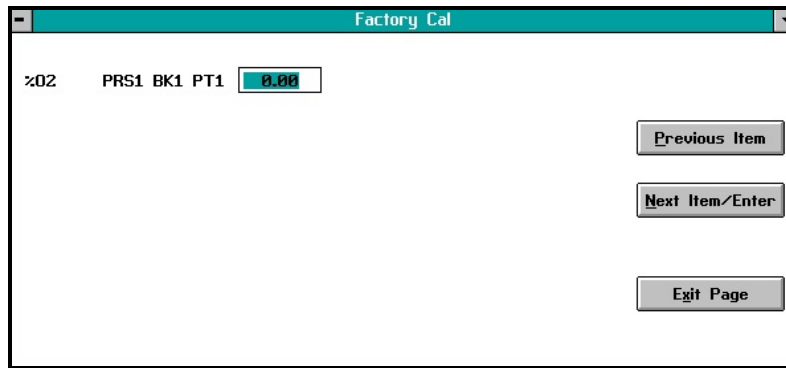

Figure 49: %O2 Data Window

4.3.2.3 Completing the Process

By using the window in *Figure 49 on page 51* and clicking on the Next Item/Enter button after each entry, you will be able to enter a value for each of the following parameters:

Note: *Note: The following list assumes that you are using both pressure and background gas compensation. If you are not*

using pressure compensation, the Pressure and Prs mV parameters do not appear. If you are not using background gas compensation, the BK mV parameter does not appear.

- %O2
- Prssure
- O2 mV
- BK mV
- Prs mV

After entering the last parameter, you will be returned to the screen shown in *Figure 49 on page 51*. Finish the programming of this section by completing the following steps:

1. Repeat the procedure beginning at *Figure 47 on page 51* until you have entered data for each parameter at all of the points listed.
2. Click on the Exit Page button to return to *Figure 45 on page 50*.
3. Repeat the procedure beginning at *Figure 45 on page 50* until you have entered data for each of the labeled background gases.
4. Click on the Exit Page button to return to *Figure 43 on page 49*.
5. Repeat the procedure beginning at *Figure 43 on page 49* until you have entered data for each of the listed pressures.
6. Click on the Exit Page button in *Figure 43 on page 49*.

You have now completed the programming of the *Factory Cal* menu and you should be back at the main meter window.

4.4 The Advanced Menu

The final option in the *Edit Functions* menu (refer to *Figure 34 on page 43*) is *Advanced*. To select this option, click on the *Advanced* button, and a window similar to *Figure 50* below opens.

IMPORTANT: *You cannot enter this menu unless you have a valid password. Your assigned password is listed on the page at the end of this chapter.*



Figure 50: Password Window

Enter your password in the text box above and click on the *Next Item/Enter* button. Then, a window similar to *Figure 51* below opens.

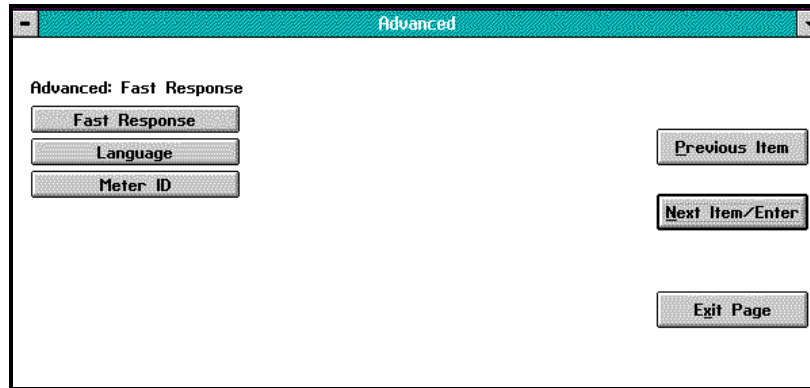

Figure 51: *Advanced* Main Menu

The following options are available in this menu:

- *Fast Response* - a software enhancement resulting in faster performance under certain conditions
- *Language* - change the language used for the XMO2 menus
- *Meter ID* - change the meter identification number

To select one of the above options, click on the corresponding button in the window above and proceed to the appropriate section for instructions.

4.4.1 Fast Response

IMPORTANT: *ATEX compliance requires both:*

- *Fast Response* calibration of the XMO2 transmitter
- *Pressure Compensation* of the XMO2 or constant control of the sample system pressure.

IMPORTANT: *The response type has been factory preset for your application requirements. If considering a response-type change, always contact Panametrics first.*

When you select the *Fast Response* option, a window similar to *Figure 52* below opens.

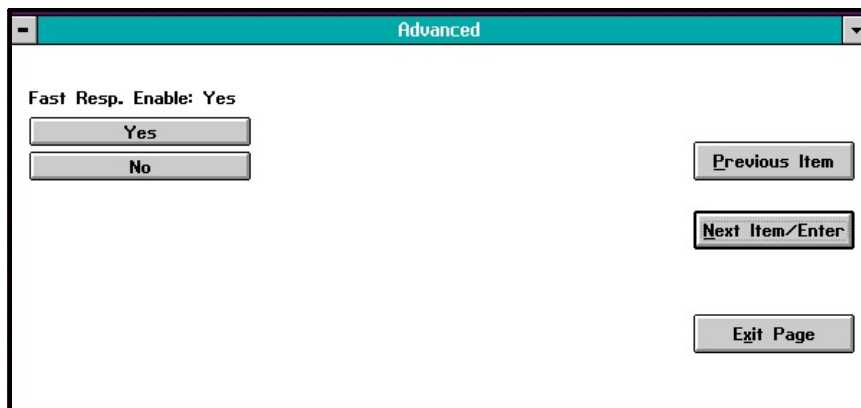

Figure 52: *Fast Response* Window

Click on the appropriate button to either *enable* or *disable* the *Fast Response* software. If you clicked on the *No* button to disable *Fast Response*, you are immediately returned to the *Advanced* main menu. However, if you clicked on the *Yes* button to enable *Fast Response*, you are prompted to enter values for the following three parameters:

- Fast Tau up
- Fast Tau down

- Fast Threshold %FS

Enter a value for the first parameter, and click on the *Next Item/Enter* button to confirm the entry and move to the next parameter. After confirming the final parameter, you are returned to the *Advanced* main menu.

CAUTION! Do not change the factory default values for any of these parameters without first contacting Panametrics.

4.4.2 Language

When you click on the *Language* button, a window similar to *Figure 53* below opens.

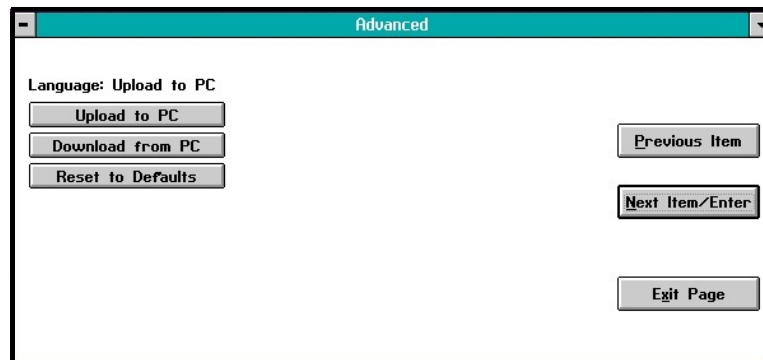

Figure 53: Language Window

The standard language used for the XMO2 menus is *English*, and these strings are stored in a meter file called *default.txt*. If you wish to translate this file into another language, click on the *Upload to PC* button, and a window similar to *Figure 54* below opens.

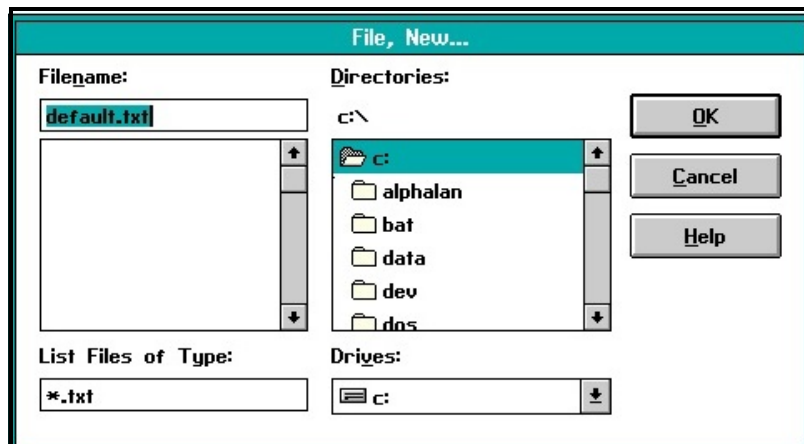

Figure 54: Creating a Data File

In the above window, specify the directory on your PC where you want to copy the *default.txt* file and click on the *OK* button. The file will be saved to your PC and you will be returned to the *Language* main menu. Next, open the PC file in any word processor and translate the menu strings into the desired language. Be very careful not to change any of the formatting or punctuation in the file. Finally, save the file with a new name (*.txt).

To load your translated menu string file into the XMO2, click on the *Download from PC* button to open a window similar to *Figure 55* below.

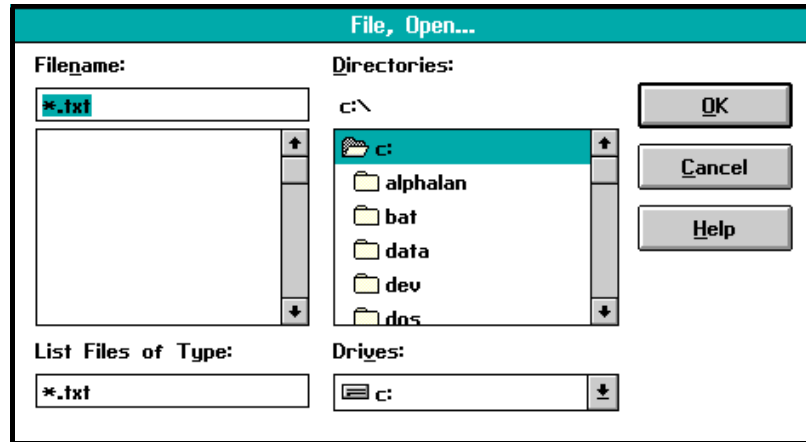

Figure 55: Downloading a Data File

In the above window, navigate to the location and name of your translated menu string file on the PC and click on the OK button. The new file will be loaded into the XMO2. After you power down the meter and restart it, all of the menus will be displayed in the new language. [no content intended for this page]

If after loading a new text file in a different language, you wish to return to the original English menus, simply click on the *Restore to Defaults* button. The XMO2 will reload a copy of the factory default.txt file from its memory and the menus will once again appear in English.

4.4.3 Meter ID

When you click on the *Meter ID* button, a window similar to *Figure 56* below opens.

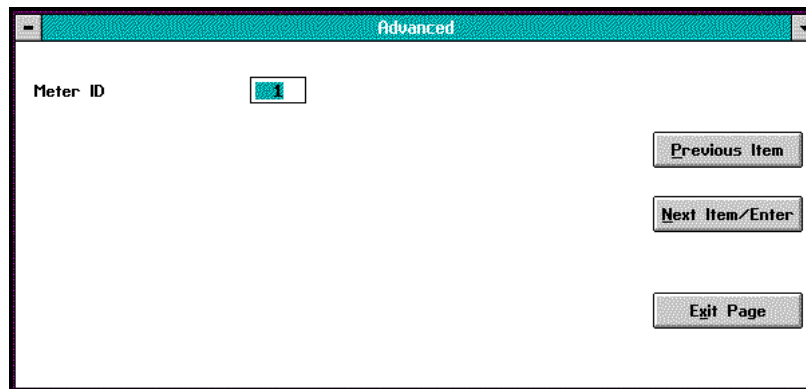

Figure 56: Meter ID Window

At the above window, you may either leave the existing meter ID number without change, or enter a new meter ID number. In either case, click the *Next Item/Enter* button to confirm the entry (or click the *Previous Item* or *Exit Page* button to leave the window without changing the meter ID number).

If you changed the existing meter ID number, a window similar to *Figure 57* below opens.

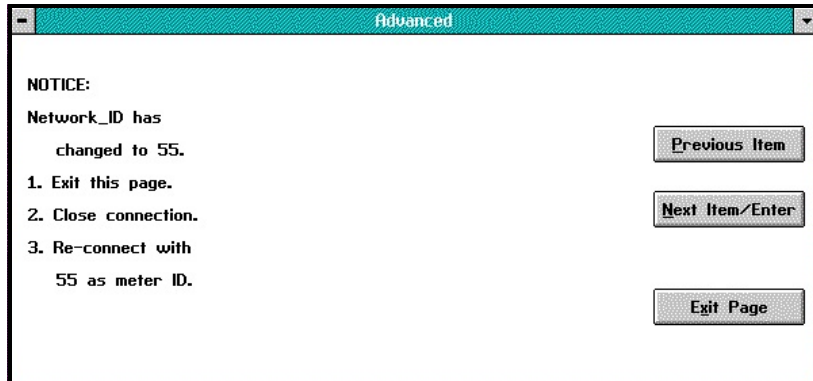

Figure 57: Instructions for New Meter ID Number

Note the instructions above for reconnecting your XMO2 to the PC using the new meter ID number. Then, click on the Next Item/Enter or Exit Page button to return to the Advanced main menu.

IMPORTANT: *Once you have entered a new meter ID number, you cannot immediately change the number again. You must exit the page, close the connection, and reconnect the meter using the new meter ID number. If you wish, you may then repeat the process to enter another meter ID number.*

Your assigned password is: 2719.

[Please copy this page and keep it in a safe place for future reference.]

Chapter 5. Specifications

5.1 Performance

Accuracy	±1% of span ±2% of span for 0 to 1% range ±0.2% O ₂ for 90 to 100% and 80 to 100%
Linearity	±0.5% of span
Repeatability	±0.2% of span
Measurement Resolution	0.01 mA
Stability	<i>Zero</i> : ±1.0% of span per month (±2% of 0-1% O ₂ range) <i>Span</i> : ±0.4% of span per month (±0.8% for 0-1% O ₂ range)
Response Time, 90% Step Change	Fast 15 seconds EN50104 45 seconds Standard 70 seconds
Measurement Ranges (typical)	0-1% 0-2% 0-5% 0-10% 0-21% 0-25% 0-50%* 0-100%* 80-100%* 90-100%* *Pressure compensation required
Transmitter Temperature	Standard: Controlled to 113°F (45°C) Optional: Controlled to 140°F (60°C)
Atmospheric Pressure Effect	<i>Standard</i> : ±0.2% of span per mm of Hg <i>Optional</i> : Pressure compensation
Required Sample Gas Flow Rate	<i>Range</i> : 0.1 to 2.0 SCFH (50 to 1,000 cc/min) <i>Nominal</i> : 1.0 SCFH (500 cc/min) nominal
Sample Gas Flow Rate Effect	<1% of span, with weatherproof enclosure, background gas compensation, and 0.1-2.0 SCFH (50-1,000 cc/Min) flow rate
Warmup Time	30 minutes

5.2 Functional Specifications

Analog Output	4-20 mA isolated, 800 Ω max, load, isolated, field-programmable
Digital Output	RS232, 3-conductor
Power Input	24.0 VDC ±4 VDC @ 1.2 A maximum
Cable (Power Input and Analog Output)	<i>Standard</i> : 10 ft (3 m), 4-conductor, shielded, P/N X4(10); lengths up to 4000 ft. <i>Optional</i> : lengths to 450 ft. (137 m) available
Cable (Digital Output)	6 ft (2 m), 3-conductor, shielded, P/N 704-667, 668, 669, or 670 <i>Connector</i> : DB9 male, DB9 female, DB25 male, or DB25 female <i>Lengths</i> : up to 4,000 ft (1,200 m)
Operating Temperature	<i>Standard</i> : +45°C (+113°F) <i>Optional</i> : +60° or +70°C (+140°F or +158°F)

Ambient Temperature Range *Standard 45°C unit: -20° to +40°C (-4° to +104°F)*
 Optional 60°C unit: -5 to 55°C (23 to 131°F)

Sample Gas Pressure Range: 20 psig maximum

5.3 Physical Specifications

Sensor Wetted Materials	<i>Standard:</i> 316 SS, glass, and Viton™ o-rings <i>Optional:</i> Hastelloy, Monel, or Titanium with Chemraz™ o-rings
Dimensions	<i>Weatherproof unit:</i> 9.53" (H) x 5.71" (D) (242 x 145 mm) <i>Explosion-proof unit:</i> 10.47" (H) x 5.71" (D) (266 x 145 mm)
Weight	9.5 lb (4.3 kg)
Connections	<i>Electrical:</i> 3/4 in. NPTF conduit and 6-terminal, removable connector <i>Process:</i> 1/4 in. NPTF inlet and outlet
Environmental	<i>Weatherproof:</i> Class I Div. 1 Groups A, B, C & D Class II, III Div. 1 Groups E, F & G Tamb 55°C T6 Type 4X <i>Flameproof:</i> I TS12ATEX17703X IECEX ITS 12.0058X II 2 G Ex d IIC T6 Gb IP66 -20°C < Tamb < +55°C All conduit entries 3/4" NPT <i>CE:</i> EMC 2004/108/EC PED 97/23/EC Lloyd's Registry approval Note: For CE compliance, the power and I/O cables must be shielded. All cables must be terminated within the cable gland at the XMO2. Note: See the Certification Drawings in Appendix B, Outline and Installation Drawings, for additional details.

5.4 Optional Accessories

Panametrics offers a complete line of optional accessories for use with the XMO2 transmitter. These include:

- **PS5R-C24:** 24 VDC power supply
- **X4(*):** 4-conductor cable for power input and analog output connections (* specifies length in feet) lengths up to 450 ft (137 m) are available
- **704-(667, 668, 669, or 670)-*:** 3-conductor cable for digital output connections (* specifies length in feet) DB9 male, DB9 female, DB25 male, and DB25 female connectors are available

The XMO2 can also be interfaced with other Panametrics displays and analyzers, such as:

- **TMO2D, moisture.IQ,** and **XDP** display/control modules
- **Moisture Image Series 1** and **Moisture Monitor Series 3** Analyzers
- **System 1** Analyzer

5.5 Ordering Information

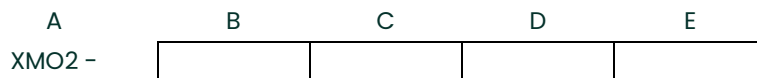

A: Transmitter Model
XMO2 -

B: Measuring Cell Package (requires 24 VDC, 1.2 A power supply)

- 1 - Weatherproof Enclosure
- 2 - Explosion-Proof/Flameproof Enclosure
- X - Without Enclosure (Spare Cell)

C: CE Compliance

- H - Standard
- C - Compliant

D: Compensation

- 1 - Background gas compensation only (standard)
- 2 - Atmospheric pressure and background gas compensation (optional)
- 3 - background gas compensation only, IDM user program
- 4 - atmospheric pressure & background gas compensation, IDM user program.

E: Wetted Material

- 1 - 316 stainless steel
- 2 - Hastelloy C-276 / Chemraz O rings

5.6 Calibration Specification

A	B	C
XMO2 -		

A: Transmitter Model
XMO2

B: Range of Oxygen Output

- 1 - 0-1%
- 2 - 0-2%
- 3 - 0-5%
- 4 - 0-10%
- 5 - 0-21%
- 6 - 0-25%
- 7 - 0-50% (atmospheric pressure compensation
XMO2 hardware required)
- 8 - 0-100% (atmospheric pressure compensation
XMO2 hardware required)
- A - 90-100% (atmospheric pressure compensation
XMO2 hardware required)
- B - 80-100% (atmospheric pressure compensation
XMO2 hardware required)
- S - Special

C: Compensation Signal

- 1 - Background gas only (standard gas N₂/CO₂)
- 2 - Atmospheric pressure only (standard pressure
range of 700-800 mm of Hg)
- 3 - Background gas only (special gas)
- 4 - Atmospheric pressure only (special range)
- 5 - Background gas and atmospheric pressure
(standard gas N₂/CO₂ and standard pressure
range of 700-800 mm of Hg)
- 7 - 0, 2, 10, 21% O₂ in N₂ and 14% CO₂/N₂
- S - Background gas and atmospheric pressure
(special gas and special pressure range)

5.7 A Calibration Sheet

For reference, a sample Calibration Sheet for the XMO2 transmitter is shown in *Figure 58* below.

XMO2 Calibration Sheet				
XMO2 S/N:	3389			
XMO2 Part Number:	XMO2-2H-11			
Calibration Part Number:	XCAL-511			
Compensation Type:	Background Gas N2/CO2			
Calibration Range %O2:	0 to 21%			
Work Order Number:	501010060853			
Calibration Date:	February 15, 2009			
Technician:	K. Brin			
XMO2 Calibration Data				
XMO2 Enable Compensation	Yes/Background			
XMO2 System Response	Damped			
XMO2 Oxygen Grid	4 Points, 2 Curves			
XMO2 Recorder	4 to 20 mA 0 to 21% O2			
Curve 1: in Nitrogen				
PT	%O2	O2 (mV)	Comp (mV)	O2 Output (mA)
1	0.00	-402.9	243.3	4.00
2	10.00	-182.7	243.7	11.62
3	20.00	-3.9	244.1	19.24
4	20.93	13.7	244.2	19.95
Curve 2: in Carbon Dioxide				
PT	%O2	O2 (mV)	Comp (mV)	O2 Output (mA)
1	0.00	-390.6	220.6	4.00

Figure 58: Sample XMO2 Calibration Sheet

Appendix A. Two Typical Applications

A.1 Blanketing Gases in Hydrocarbon Liquid Storage Tanks

The XMO2 transmitter and its associated sample system is often used to measure the concentration of oxygen (O_2) in the nitrogen (N_2) or carbon dioxide (CO_2) gases used to blanket hydrocarbon liquids during storage.

A.1.1 The Problem

Air can leak into the vapor space above hydrocarbon liquids stored in tanks or process vessels, forming a potentially explosive gas mixture. To solve this problem, inert gases such as N_2 or CO_2 are often used to purge the vapor space above the stored liquid and dispel any O_2 that may have leaked into that space. In such a system, one must constantly monitor the level of O_2 in the vapor space to make sure that an explosive gas mixture does not form.

A.1.2 Equipment Used

A typical instrumentation package for this application includes an XMO2 transmitter configured for a range of 0-21% O_2 in N_2 or CO_2 and operating conditions of ambient temperature and atmospheric pressure. The XMO2 is mounted in a sample system similar to the one shown in *Figure 59* below (ref. dwg. #731-559).

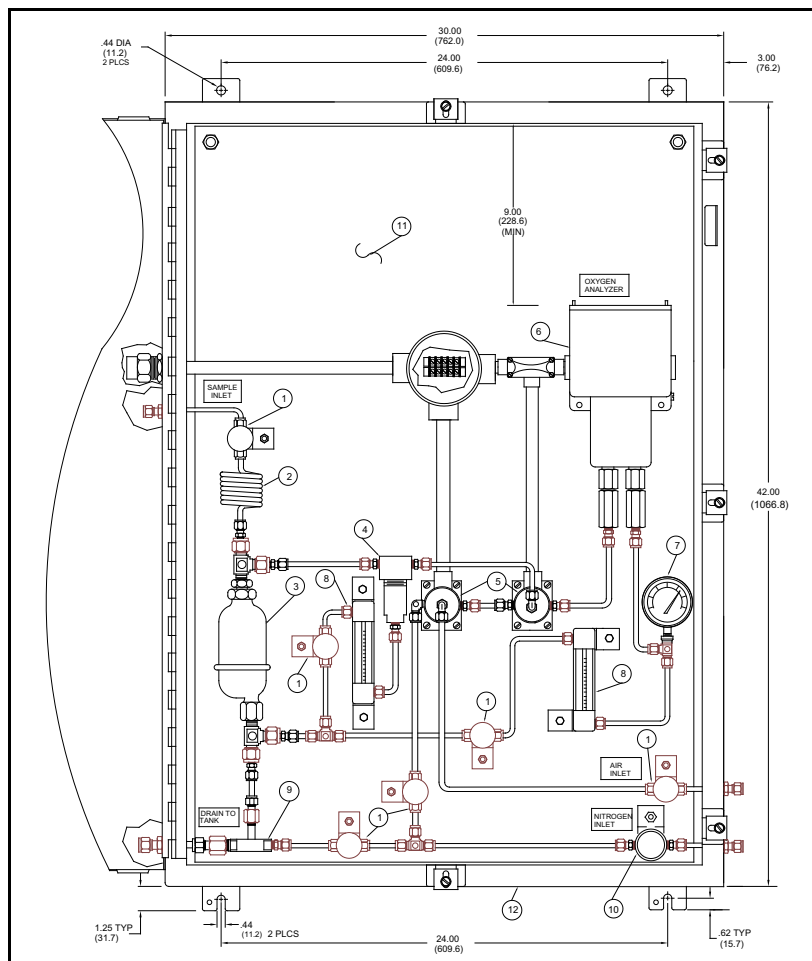

Figure 59: Blanketing Gas Sample System

The sample system in *Figure 59* on page 63 consists of:

- An eductor to draw the sample from and return it to the vapor space above the liquid in the storage tank

- A liquid separator/dump to remove condensable liquids
- A filter/coalescer for the removal of solid and liquid particulates
- Automatic calibration gas solenoid valves for the automatic calibration of the system on a timed basis
- Flowmeters
- Pressure gauges

All components are mounted on a painted steel plate that is usually housed in a heated enclosure.

Note: An optional TMO2D display/controller (or similar device) is required for automatic calibration of the XMO2.

A.1.3 Basic Operating Procedure

The sample system should be located at or near the top of the storage tank so that condensate can drip back into the tank. The gas used to purge the tank provides the motive force in the eductor to pull a gas sample from the vapor space above the hydrocarbon liquid into the sample system. The sample gas, condensed liquids, and the inert gas are all returned to the tank, making this a closed-loop system. The XMO2 is recalibrated periodically using the purge gas to zero the instrument and ambient air (20.93% O₂) to span the instrument. The span gas can optionally be vented to atmosphere, so that air is not introduced into the storage tank.

For this application the required calibration gases are:

- *Zero Gas:* N₂ or CO₂ (at least 99.95% pure)
- *Span Gas:* air (20.93% O₂)

A.1.4 Previous Systems

Electrolytic cells were once commonly used for this application. However, such systems required extensive maintenance and frequent manual calibration. In addition, the cells were easily damaged by condensable liquids, requiring frequent cell replacement. As the XMO2 provides continuous monitoring of the O₂ content with maintenance-free operation, it is now the system of choice.

A.2 Reactor Feed Gases in Formaldehyde Production

The XMO2 transmitter and its associated sample system is often used to measure the concentration of oxygen (O_2) in an air/methanol (CH_3OH) vapor mixture that is commonly used as a reactor feed gas in the production of formaldehyde.

A.2.1 The Problem

In order to maximize the yield of the reaction, while maintaining the O_2 concentration at a safe level, the air/ CH_3OH vapor mixture must be continuously monitored and accurately controlled.

A.2.2 Equipment Used

A typical instrumentation package for this application includes an XMO2 transmitter configured for a range of 0-21% O_2 in N_2 or CO_2 and operating conditions of a controlled temperature and atmospheric pressure. The XMO2 is mounted in a sample system similar to the one shown in *Figure 60* below (ref. dwg. #731-185).

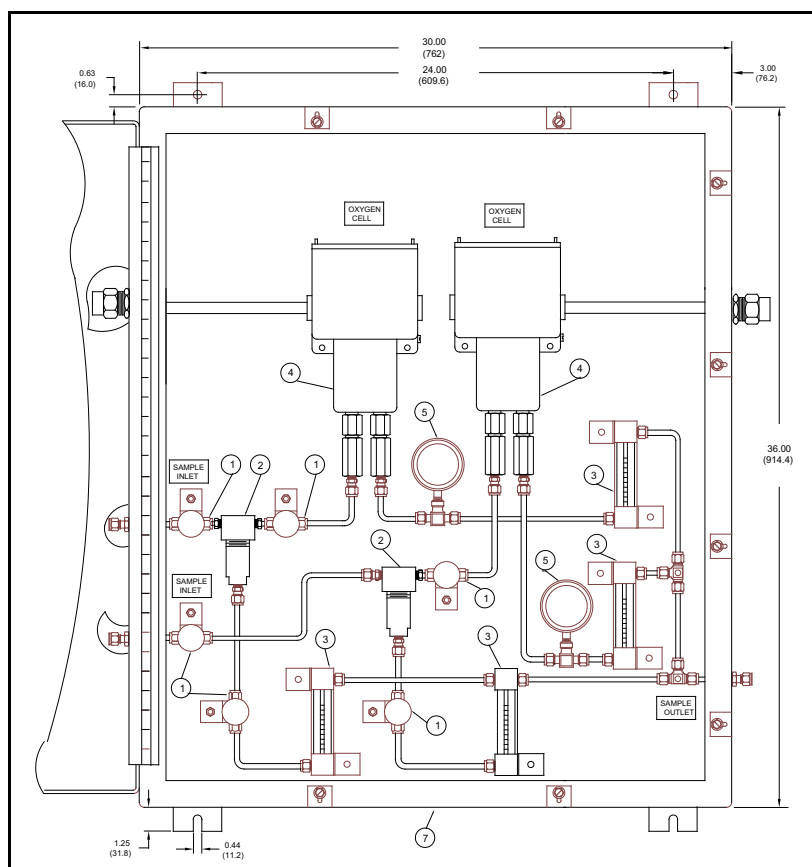

Figure 60: Formaldehyde Feed Gas Sample System

The sample system in *Figure 60 on page 65* consists of:

- Inlet, outlet, and calibration needle valves
- A filter/coalescer assembly
- Pressure gauges
- Flowmeters

All components are mounted on a painted steel plate in an enclosure that is heated to $75 \pm 10^\circ\text{F}$.

A.2.3 Basic Operating Procedure

The sample system should be mounted as close as possible to the reactor inlet in order to minimize lag time. Air (20.93% O_2) is used as the source of O_2 , and the air/ CH_3OH vapor mixture is sampled at the reactor inlet. The XMO2 continuously verifies that the optimal amount of O_2 (typically 9.8%) is present for the reaction to proceed safely to a maximized yield. Too low an O_2 level will decrease the yield, while too high an O_2 level will create a safety hazard.

For this application the required calibration gases are:

- *Zero Gas*: N_2 (at least 99.95% pure - 0.0% O_2)
- *Span Gas*: air (20.93% O_2)

Note: *Any compatible display device may be specified.*

A.2.4 Previous Systems

Dumbbell-type paramagnetic O_2 sensors were once commonly used for this application. However, such systems required extensive maintenance and frequent manual calibration. In addition, the sensors were easily damaged by condensable liquids, requiring frequent sensor replacement. As the XMO2 provides continuous, accurate monitoring of the reactor feed gas O_2 content with maintenance-free operation and excellent calibration stability, it is now the system of choice.

Appendix B. Outline and Installation Drawings

This appendix includes the following XMO2 drawings in 11" x 17" fold-out format:

- Figure 61 on page 69
- Figure 62 on page 70
- Figure 63 on page 71
- Figure 64 on page 72
- Figure 65 on page 73
- Figure 66 on page 74
- Figure 67 on page 75
- Figure 68 on page 76
- Figure 69 on page 77
- Figure 70 on page 78
- Figure 71 on page 79
- Figure 72 on page 80
- Figure 73 on page 81

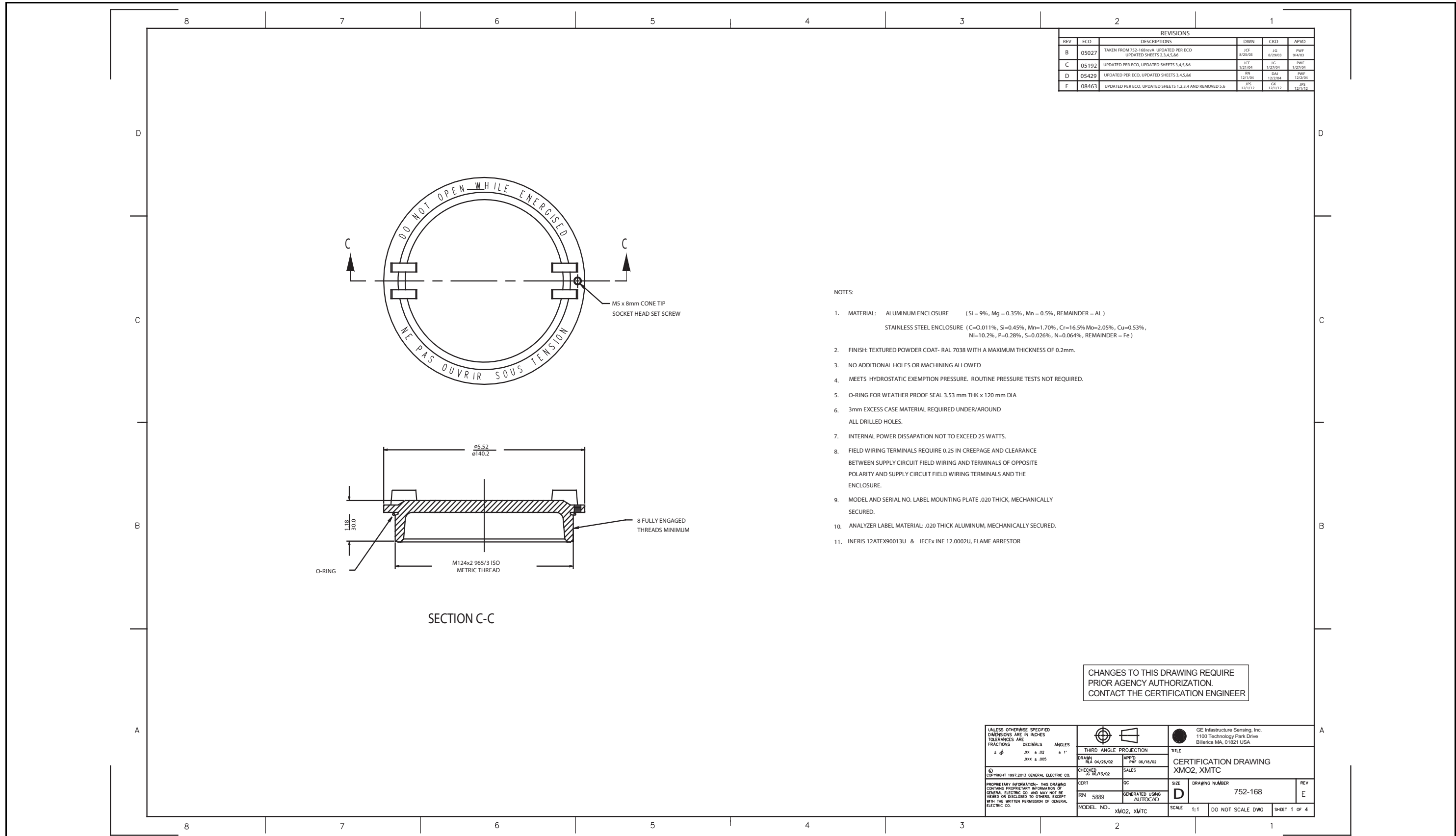

REVISIONS					
REV	ECO	DESCRIPTIONS	DWN	CKD	APVD
B	05027	TAKEN FROM 752-168revA. UPDATED PER ECO. UPDATED SHEETS 2,3,4,5,6,6	JCF 8/25/03	JG 8/25/03	PWF 8/4/03
C	05192	UPDATED PER ECO. UPDATED SHEETS 3,4,5,6,6	JCF 1/21/04	JG 1/27/04	PWF 1/27/04
D	05429	UPDATED PER ECO. UPDATED SHEETS 3,4,5,6,6	BN 12/1/04	DAI 12/2/04	PWF 12/2/04
E	08463	UPDATED PER ECO. UPDATED SHEETS 1,2,3,4 AND REMOVED 5,6	JPS 12/1/12	GR 12/1/12	JPS 12/1/12

NOTES:

- MATERIAL: ALUMINUM ENCLOSURE (Si = 9%, Mg = 0.35%, Mn = 0.5%, REMAINDER = AL)
STAINLESS STEEL ENCLOSURE (C=0.011%, Si=0.45%, Mn=1.70%, Cr=16.5% Mo=2.05%, Cu=0.53%, Ni=10.2%, P=0.28%, S=0.026%, N=0.064%, REMAINDER = Fe)
- FINISH: TEXTURED POWDER COAT- RAL 7038 WITH A MAXIMUM THICKNESS OF 0.2mm.
- NO ADDITIONAL HOLES OR MACHINING ALLOWED
- MEETS HYDROSTATIC EXEMPTION PRESSURE. ROUTINE PRESSURE TESTS NOT REQUIRED.
- O-RING FOR WEATHER PROOF SEAL 3.53 mm THK x 120 mm DIA
- 3mm EXCESS CASE MATERIAL REQUIRED UNDER/AROUND ALL DRILLED HOLES.
- INTERNAL POWER DISSIPATION NOT TO EXCEED 25 WATTS.
- FIELD WIRING TERMINALS REQUIRE 0.25 IN CREEPAGE AND CLEARANCE BETWEEN SUPPLY CIRCUIT FIELD WIRING AND TERMINALS OF OPPOSITE POLARITY AND SUPPLY CIRCUIT FIELD WIRING TERMINALS AND THE ENCLOSURE.
- MODEL AND SERIAL NO. LABEL MOUNTING PLATE .020 THICK, MECHANICALLY SECURED.
- ANALYZER LABEL MATERIAL: .020 THICK ALUMINUM, MECHANICALLY SECURED.
- INERIS 12ATEX90013U & IECEX INE 12.0002U, FLAME ARRESTOR

CHANGES TO THIS DRAWING REQUIRE PRIOR AGENCY AUTHORIZATION. CONTACT THE CERTIFICATION ENGINEER

UNLESS OTHERWISE SPECIFIED DIMENSIONS ARE IN INCHES TOLERANCES ARE FRACTIONS DECIMALS ANGLES ± .015 ± .02 ± .1° ± .005 ± .005 ± .005		THIRD ANGLE PROJECTION		GE Infrastructure Sensing, Inc. 1100 Technology Park Drive Billerica MA, 01821 USA	
DRAWN: JCF 04/26/02		APPD: PWF 06/18/02		TITLE: CERTIFICATION DRAWING XMO2, XMTC	
CHECKED: JCF 06/13/02		SALES:		DRAWING NUMBER: 752-168	
© COPYRIGHT 1997,2013 GENERAL ELECTRIC CO.		CER: RN 5889		REV: E	
PROPRIETARY INFORMATION- THIS DRAWING CONTAINS PROPRIETARY INFORMATION OF GENERAL ELECTRIC CO. AND MAY NOT BE VIEWED OR DISCLOSED TO OTHERS EXCEPT WITH THE WRITTEN PERMISSION OF GENERAL ELECTRIC CO.		MODEL NO.: XMO2, XMTC		SCALE: 1:1 DO NOT SCALE DWG SHEET 1 OF 4	

Figure 61: Certification Drawing (ref. dwg #752-168, Rev. E, SH1)

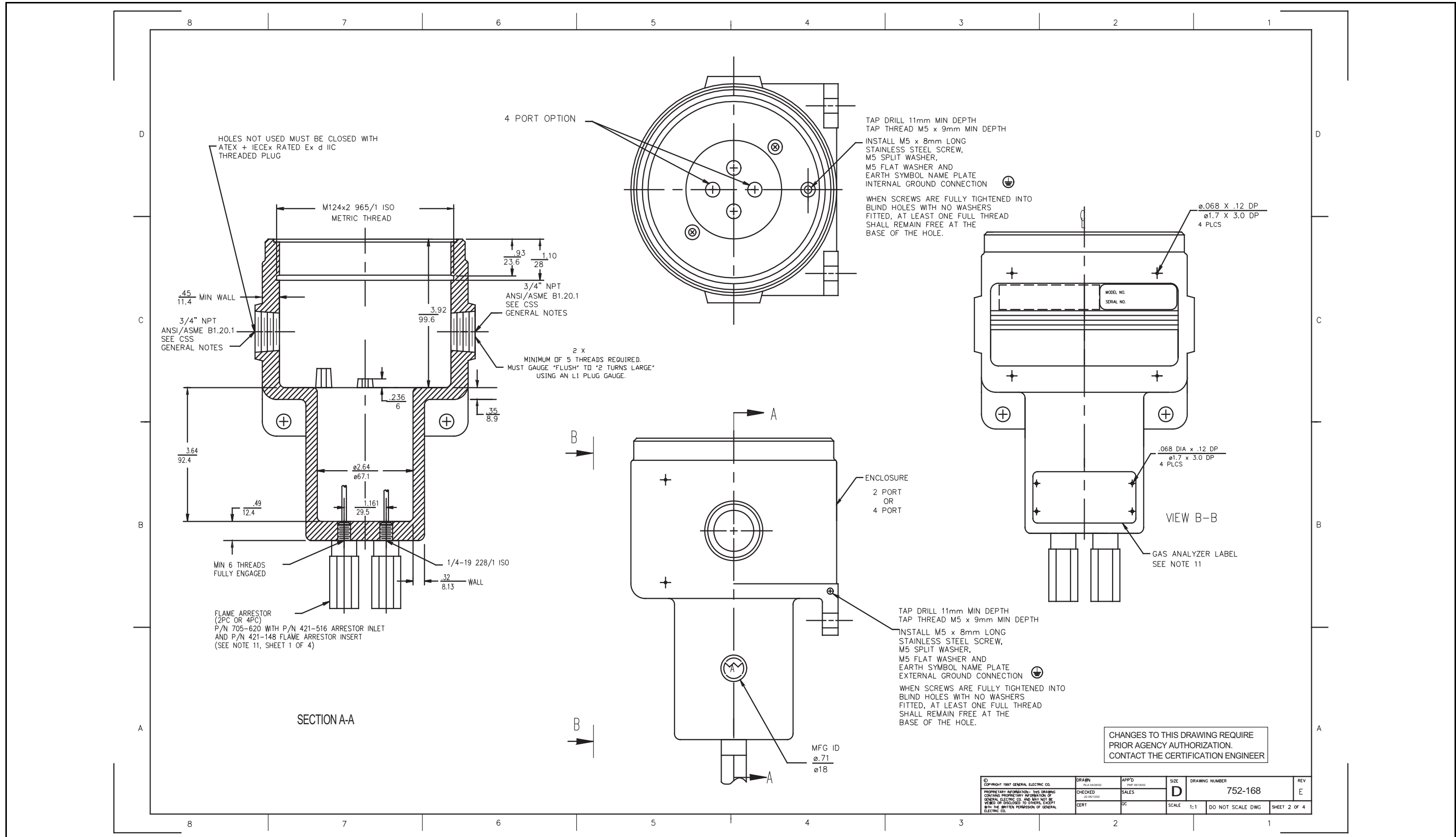

Figure 62: Certification Drawing (ref. dwg #752-168, Rev. E, SH2)

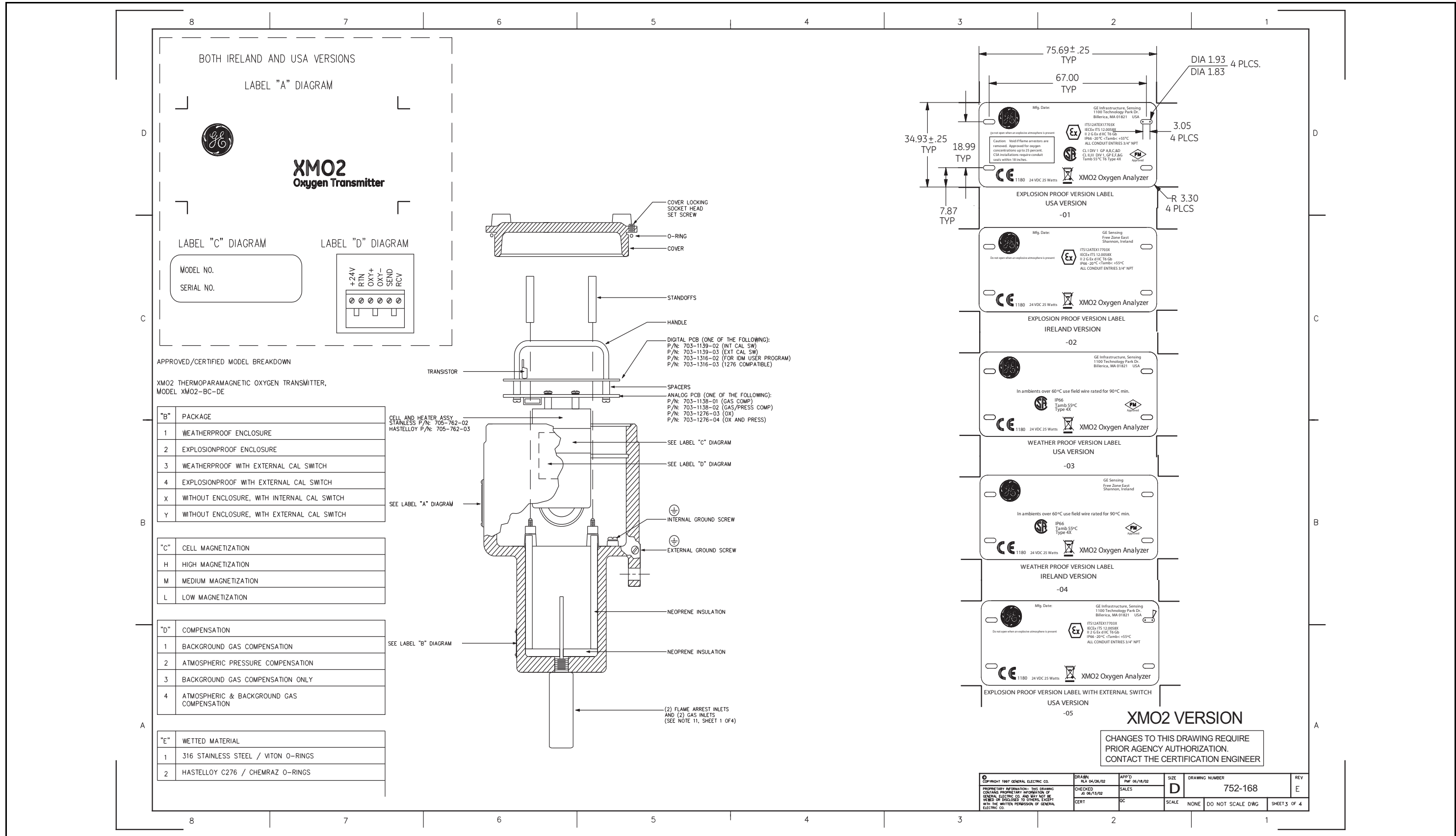
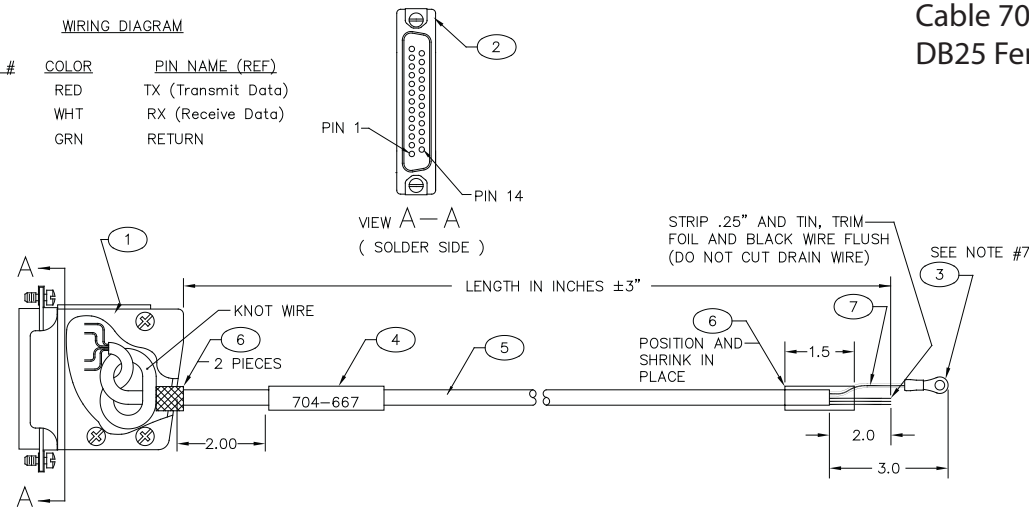

Figure 63: Certification Drawing (ref. dwg #752-168, Rev. E, SH3)

WIRING DIAGRAM

PIN #	COLOR	PIN NAME (REF)
2	RED	TX (Transmit Data)
3	WHT	RX (Receive Data)
7	GRN	RETURN



NOTES:

1. STRIP CABLE JACKET 5/8 INCH. TRIM FOIL AND BLACK WIRE FLUSH TO CABLE JACKET.
2. PLACE 1/4 LONG SLEEVE (ITEM 7, 410-039) OVER EACH CONDUCTOR.
3. STRIP/TIN CONDUCTORS TO 1/8 INCH AND SOLDER PER WIRING DIAGRAM.
4. SLIDE SLEEVING OVER SOLDER CONNECTIONS AND SHRINK IN PLACE.
5. PLACE BACKSHELL OVER CONNECTOR AND CLOSE USING INCLUDED HARDWARE.
6. SLIDE LABEL ONTO CABLE AND SHRINK IN PLACE.
7. TERMINATE REMAINING END PER DRAWING. FOLD WIRE OVER (DOUBLING UP IN LUG) AND CRIMP LUG (ITEM 1) USING AMP CRIMP TOOL 59824-1.

**Cable 704-667
DB25 Female**

WIRING DIAGRAM

PIN #	COLOR	PIN NAME (REF)
2	WHT	RX (Receive Data)
3	RED	TX (Transmit Data)
5	GRN	GND (Ground)

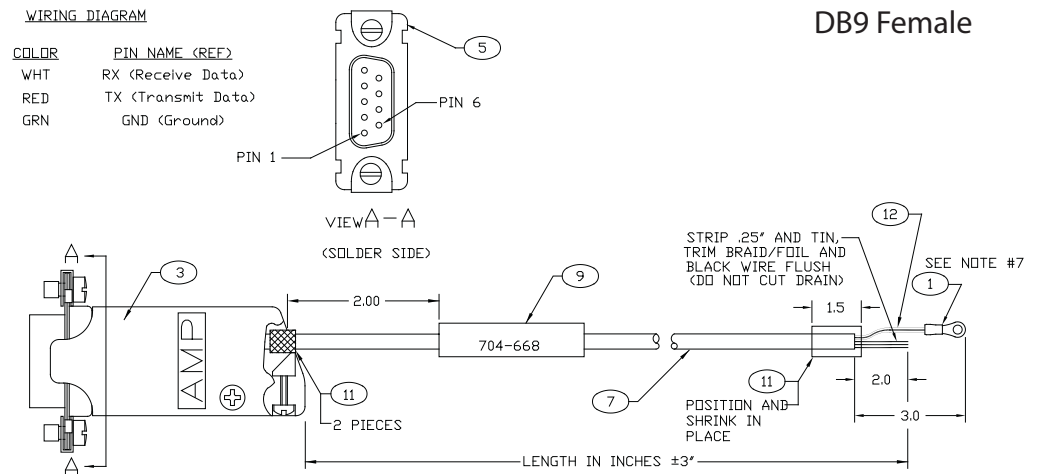

NOTES:

1. STRIP CABLE JACKET 5/8 INCH. TRIM FOIL AND BLACK WIRE FLUSH TO CABLE JACKET.
2. PLACE 1/4 LONG SLEEVE (ITEM 12, 410-039) OVER EACH CONDUCTOR.
3. STRIP/TIN CONDUCTORS TO 1/8 INCH AND SOLDER PER WIRING DIAGRAM.
4. SLIDE SLEEVING OVER SOLDER CONNECTIONS AND SHRINK IN PLACE.
5. PLACE BACKSHELL OVER CONNECTOR AND CLOSE USING INCLUDED HARDWARE.
6. SLIDE LABEL ONTO CABLE AND SHRINK IN PLACE.
7. TERMINATE REMAINING END PER DRAWING. FOLD WIRE OVER (DOUBLING UP IN LUG) AND CRIMP LUG (ITEM 1) USING AMP CRIMP TOOL 59824-1.

WIRING DIAGRAM

PIN #	COLOR	PIN NAME (REF)
2	RED	TX (Transmit Data)
3	WHT	RX (Receive Data)
7	GRN	RETURN

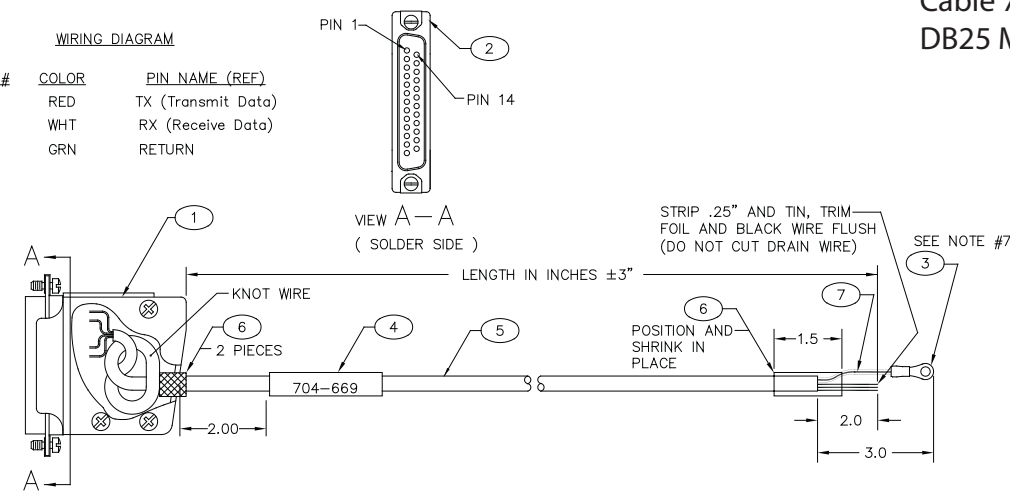

NOTES:

1. STRIP CABLE JACKET 5/8 INCH. TRIM FOIL AND BLACK WIRE FLUSH TO CABLE JACKET.
2. PLACE 1/4 LONG SLEEVE (ITEM 7, 410-039) OVER EACH CONDUCTOR.
3. STRIP/TIN CONDUCTORS TO 1/8 INCH AND SOLDER PER WIRING DIAGRAM.
4. SLIDE SLEEVING OVER SOLDER CONNECTIONS AND SHRINK IN PLACE.
5. PLACE BACKSHELL OVER CONNECTOR AND CLOSE USING INCLUDED HARDWARE.
6. SLIDE LABEL ONTO CABLE AND SHRINK IN PLACE.
7. TERMINATE REMAINING END PER DRAWING. FOLD WIRE OVER (DOUBLING UP IN LUG) AND CRIMP LUG (ITEM 3) USING AMP CRIMP TOOL 59824-1.

**Cable 704-669
DB25 Male**

WIRING DIAGRAM

PIN #	COLOR	PIN NAME (REF)
2	WHT	RX (Receive Data)
3	RED	TX (Transmit Data)
5	GRN	GND (Ground)

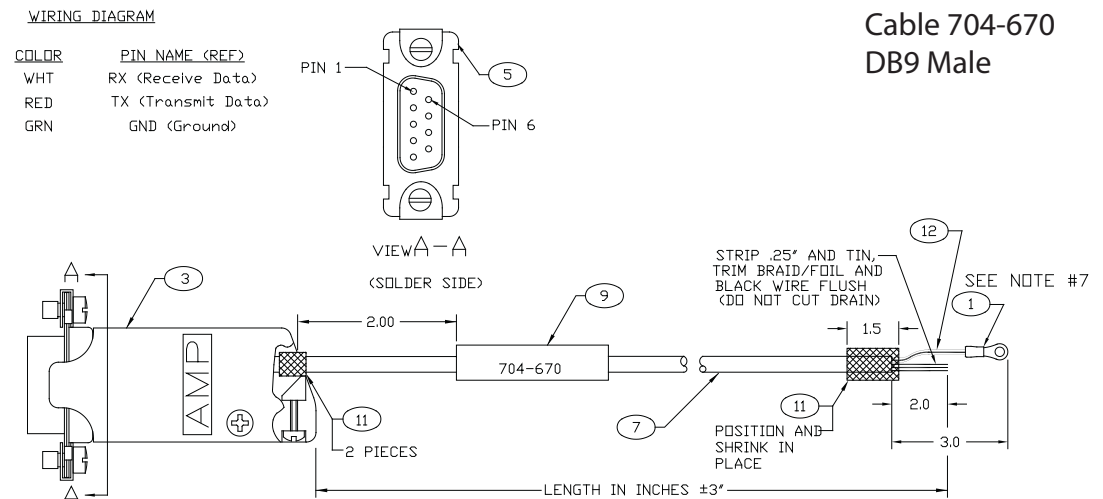

NOTES:

1. STRIP CABLE JACKET 5/8 INCH. TRIM FOIL AND BLACK WIRE FLUSH TO CABLE JACKET.
2. PLACE 1/4 LONG SLEEVE (ITEM 12, 410-039) OVER EACH CONDUCTOR.
3. STRIP/TIN CONDUCTORS TO 1/8 INCH AND SOLDER PER WIRING DIAGRAM.
4. SLIDE SLEEVING OVER SOLDER CONNECTIONS AND SHRINK IN PLACE.
5. PLACE BACKSHELL OVER CONNECTOR AND CLOSE USING INCLUDED HARDWARE.
6. SLIDE LABEL ONTO CABLE AND SHRINK IN PLACE.
7. TERMINATE REMAINING END PER DRAWING. FOLD WIRE OVER (DOUBLING UP IN LUG) AND CRIMP LUG (ITEM 1) USING AMP CRIMP TOOL 59824-1.

**Cable 704-668
DB9 Female**

**Cable 704-670
DB9 Male**

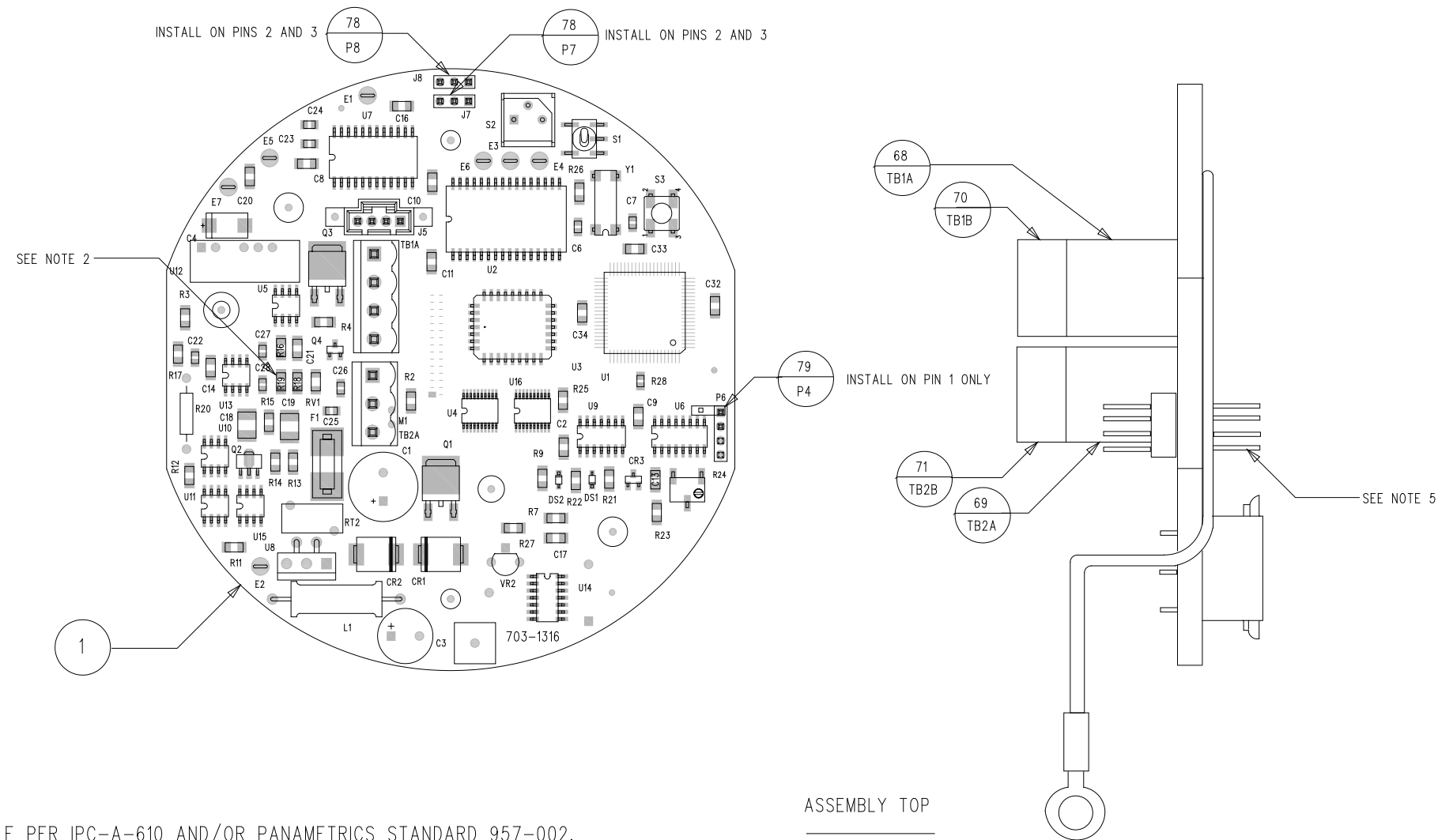

NOTES:

1. ASSEMBLE PER IPC-A-610 AND/OR PANAMETRICS STANDARD 957-002.
2. R19 NOT INSTALLED (SPECIALS ONLY)
3. ALL UNINSTALLED COMPONENT HOLES TO BE SOLDER FREE
4. DISCARD LOCKWASHER AND NUT ON S2 (DO NOT INSTALL)
5. INSTALL P6 WITH LONGER LEADS INTO PCB AS SHOWN FOR PROPER STACKUP WITH MATED ASSEMBLY. SOLDER MUST BE FLUSH TO BOARD. DO NOT CUT, TRIM OR TIN EXCESS LEADS.
6. INSTALL CHASSIS GROUND WIRE ON THE BOTTOM SIDE OF THE PCB. APPLY LOCTITE 416 INSTANT ADHESIVE AND LOCTITE 7452 ACCELERATOR OR EQUIVALENT TO TACK WIRE TO PCB.

GROUPS	
NO.	DESCRIPTION
01	STANDARD
02	02
03	TC

Figure 65: Digital PCB Assembly (ref. dwg #703-1316, rev. K, sh.1)

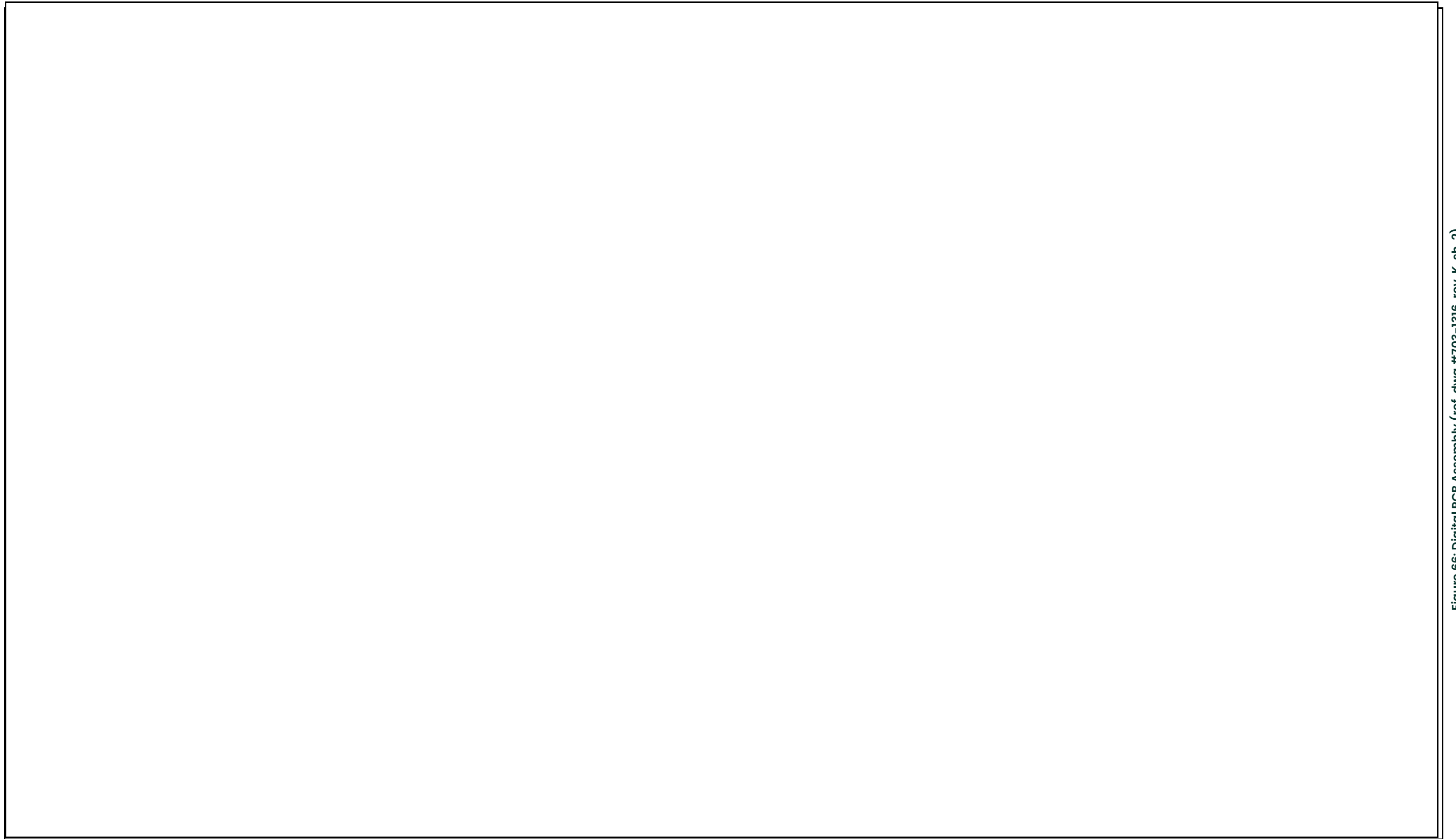

Figure 66: Digital PCB Assembly (ref. dwg #703-1316, rev. K, sh. 2)



Figure 67: Digital PCB Schematic (ref. dwg #700-1316, rev. H, sh. 1)



Figure 68: Digital PCB Schematic (ref. dwg #700-1316, rev. H, sh. 2)

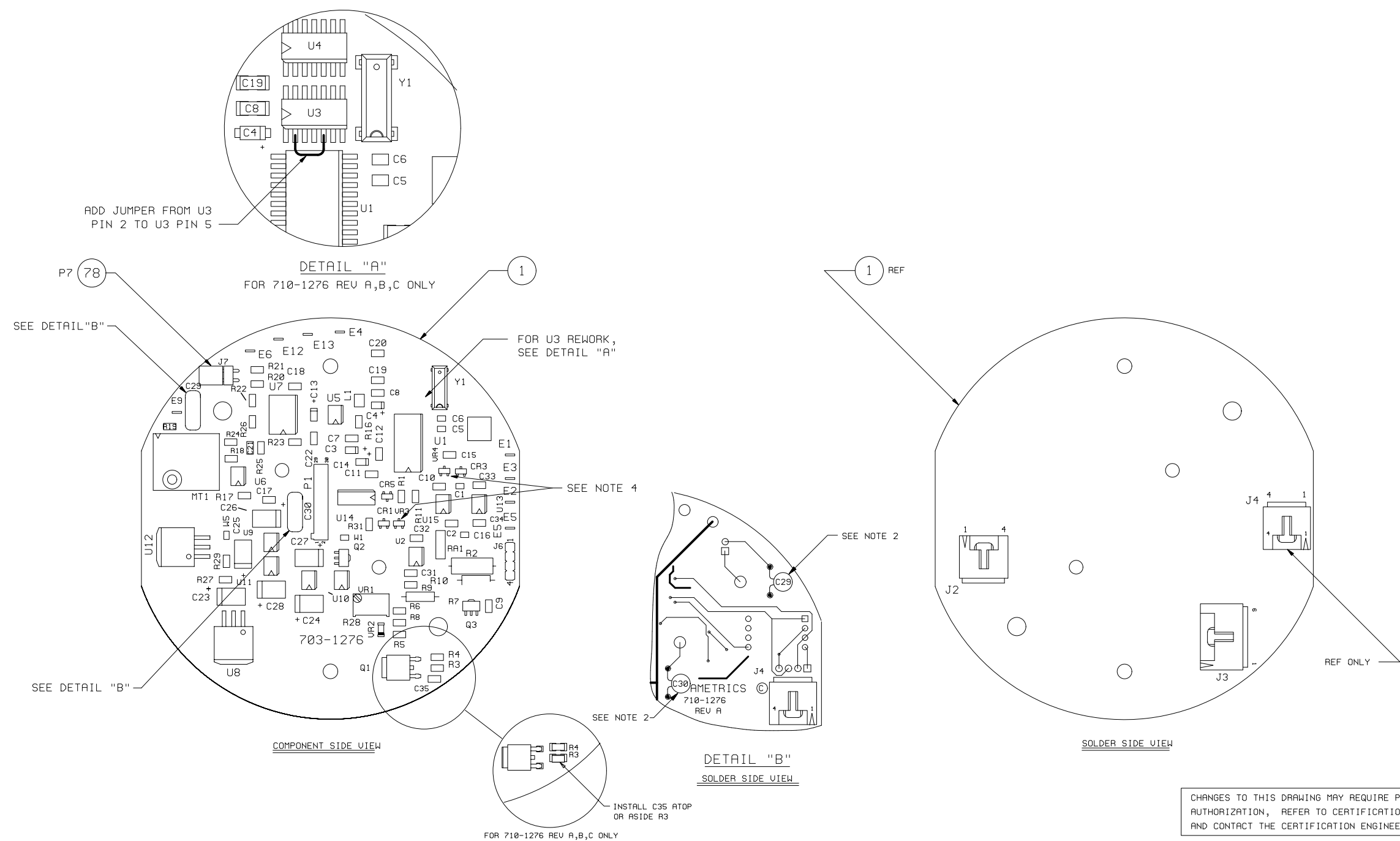

NOTES:

1. ASSEMBLE PER IPC-A-610 AND/OR PANAMETRICS STANDARD 957-002.
2. INSTALL C29 AND C30 ON SOLDER SIDE OF BOARD AS SHOWN, C29 MAY EXTEND OVER THE EDGE OF THE PCB 0.14" MAX.
3. TRIM J6 AND J7 LEADS TO 0.04 INCHES MAX HEIGHT ABOVE THE PCB.
4. INSTALL UR3 AT CR2 LOCATION AND INSTALL UR4 AT CR4 LOCATION.

CHANGES TO THIS DRAWING MAY REQUIRE PRIOR AGENCY (FM/CSA) AUTHORIZATION, REFER TO CERTIFICATION DRAWING 752-107 AND CONTACT THE CERTIFICATION ENGINEER.

GROUPS	
NUMBER	DESCRIPTION
01	STANDARD
02	TC
03	OX
04	OX + PRESS

Figure 69: Analog PCB Assembly (ref. dwg #703-1276, rev. H.)

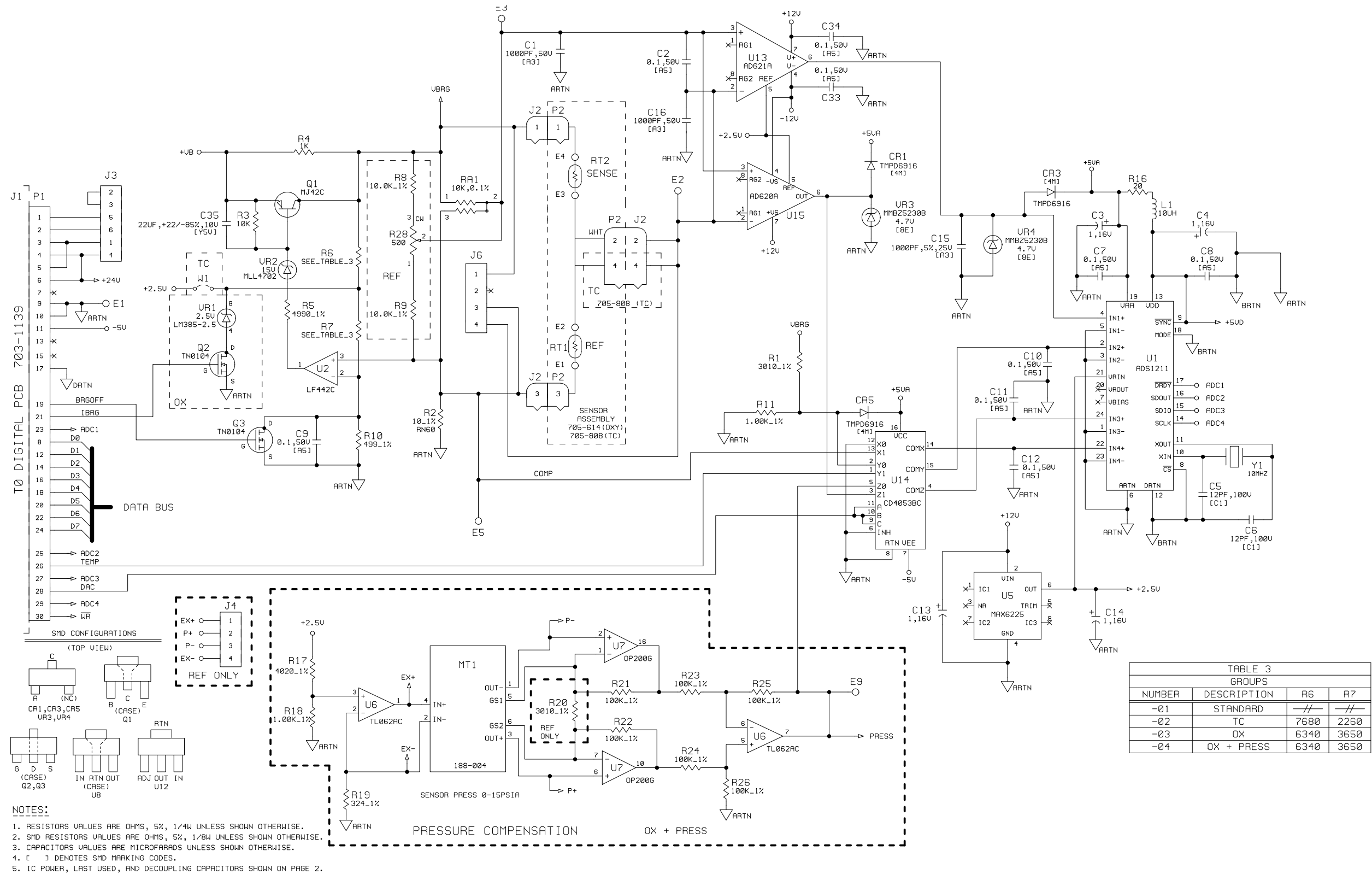

Figure 70: Analog PCB Schematic (ref. dwg #700-1276, rev. F, sh. 1)

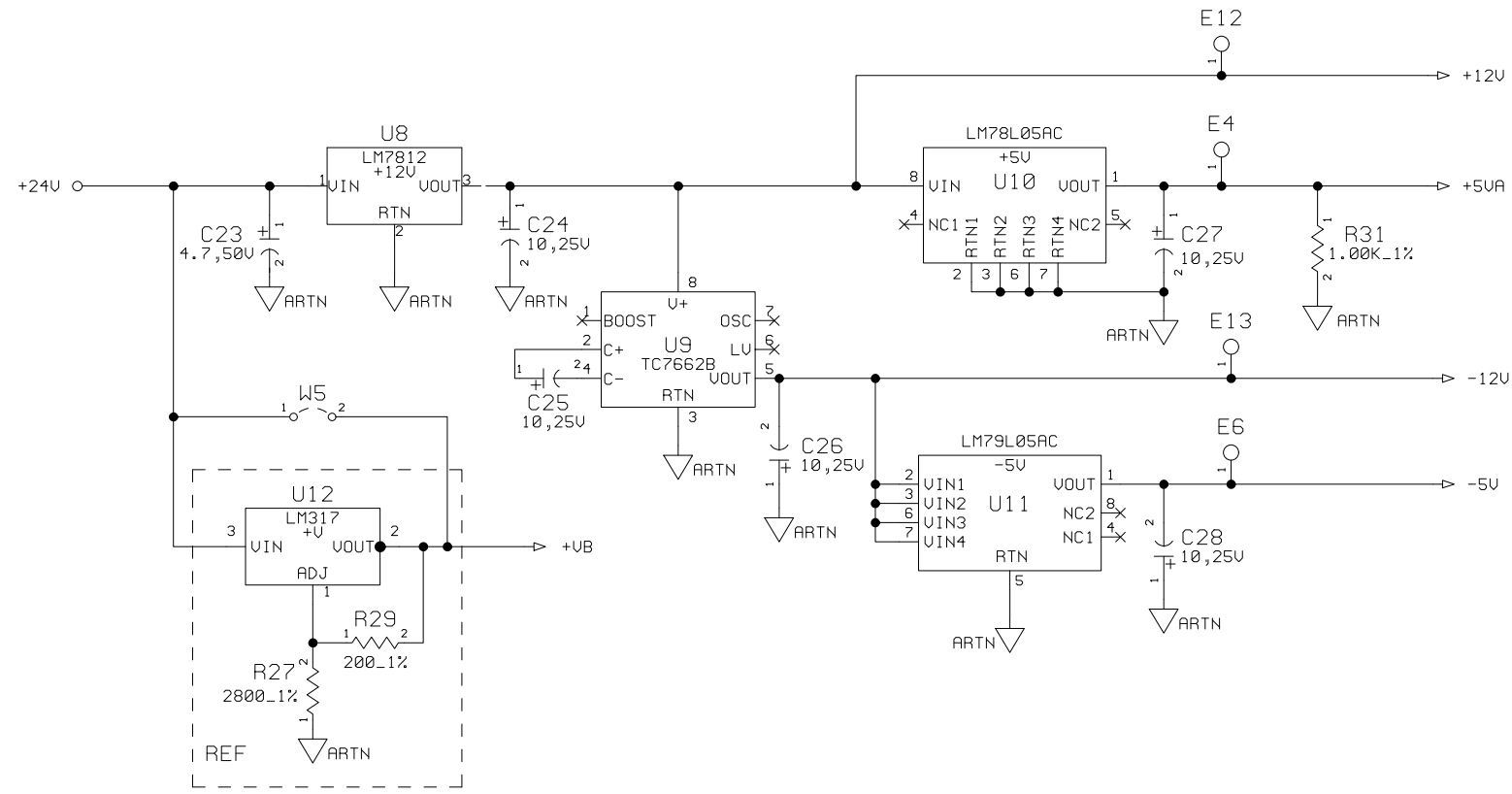

TABLE 1 POWER CHART						
REFDES	TYPE	+5VA	+5VD	+12V	-12V	BRTN ARTN
U2	LF442C			8	4	
U6	TL062AC			8	4	
U7	OP200G			13	4	

TABLE 2 REFDES	
HIGHEST USED	NOT USED
C35	
CR5	CR2, CR4
J7	J5
E13	E7, E8, E10, E11
L1	
MT1	
P7	P3-P6
Q3	
R31	R12-R15, R30
RA1	
U15	U3, U4
UR4	
W5	W2, W3, W4
Y1	

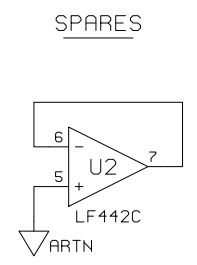
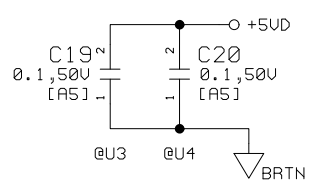
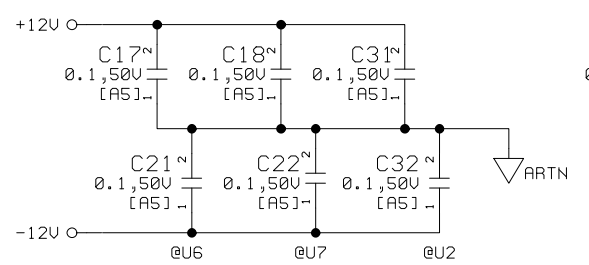
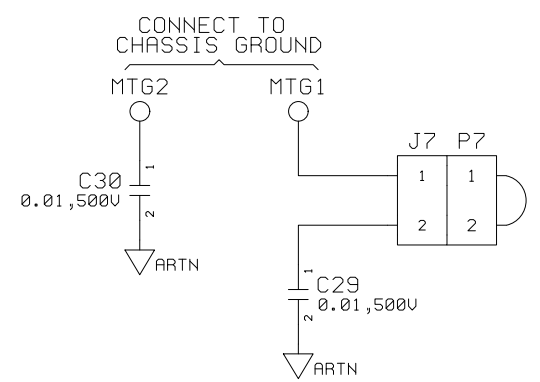
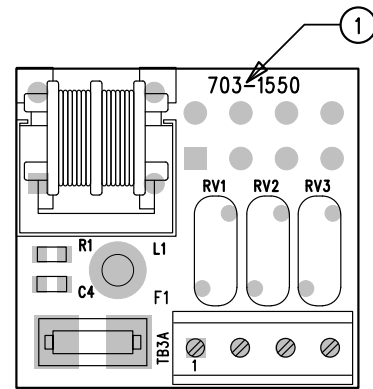
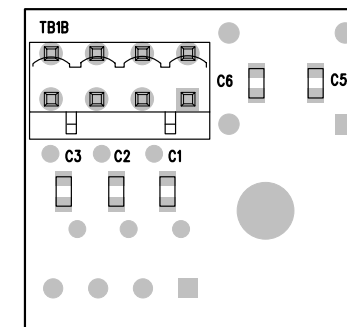

Figure 7i: Analog PCB Schematic (ref. dwg #700-1276, rev. F, sh. 2)



ASSEMBLY TOP



BOTTOM SIDE ASSEMBLY

NOTES:

1. ASSEMBLE PER IPC-A-610 AND/OR PANAMETRICS STANDARD 957-002.

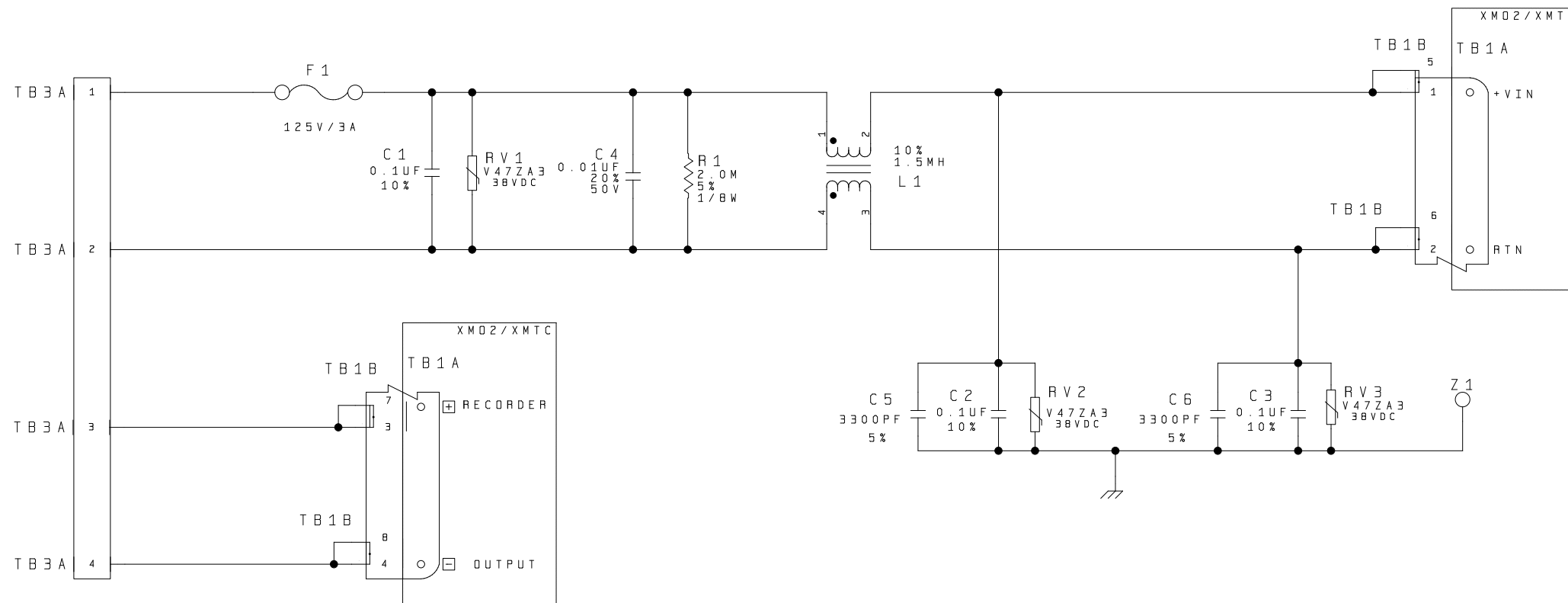
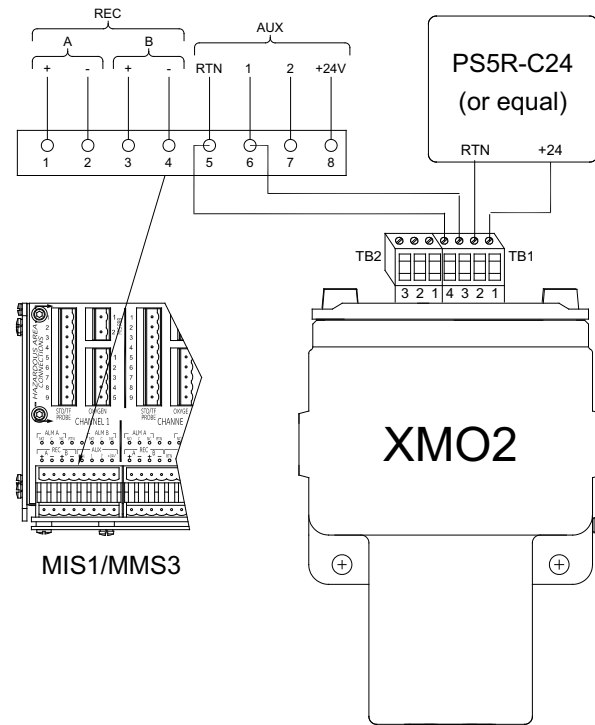

TABLE 1	
REF DES CHART	
HIGHEST USED	NOT USED
C 6	
F 1	
L 1	
R 1	
RV 3	
TB 1B	
TB 3A	TB 1A TB 2A

Figure 73: EMI Filter PCB Schematic (ref. dwg. #700-1550, rev. A)

MIS1/MMS3 Connections (see User's Manual for details)



MIS2 Connections (see User's Manual for details)

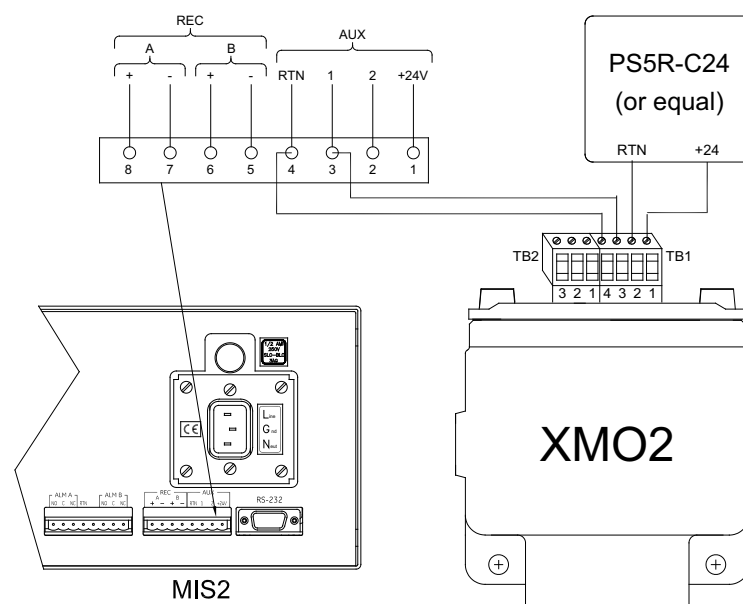

System 1 Connections (see User's Manual for details)

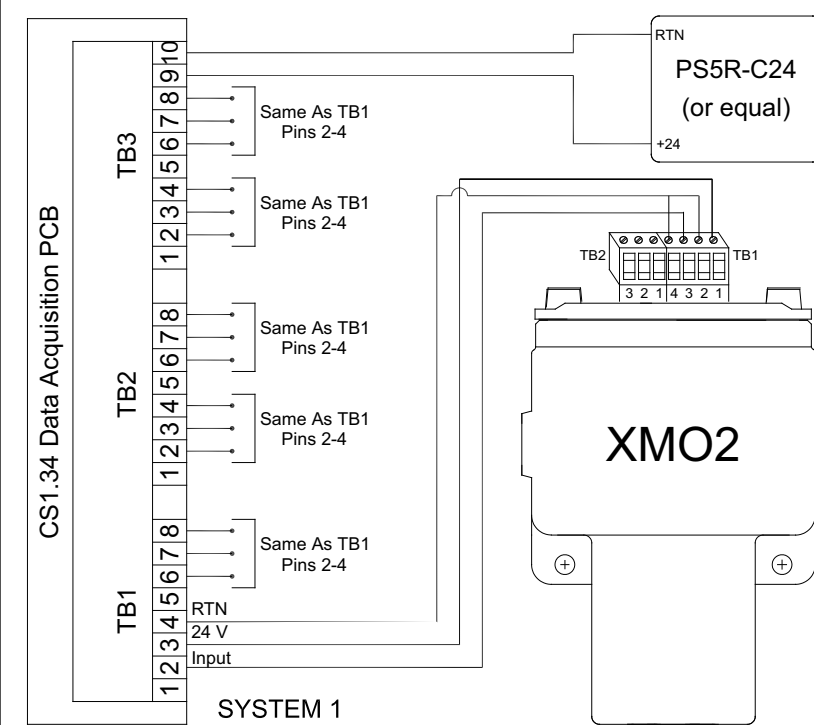

TMO2D Connections (see User's Manual for details)

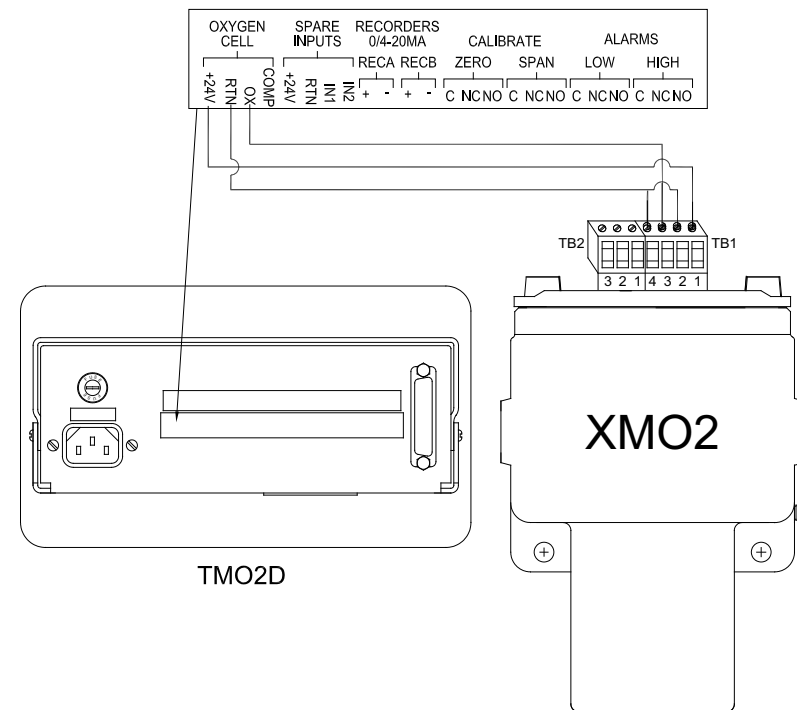

XDP Connections (see User's Manual for details)

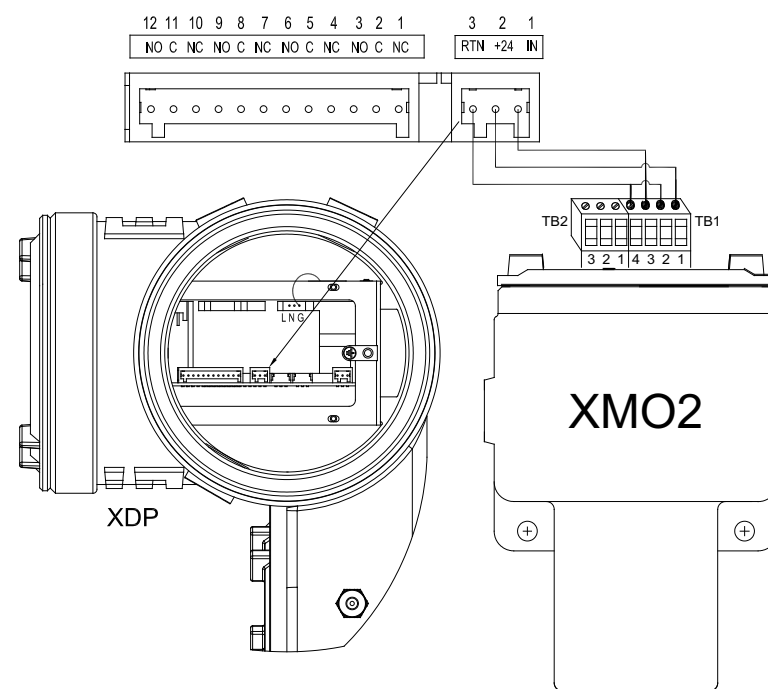

LDP Connections (see User's Manual for details)

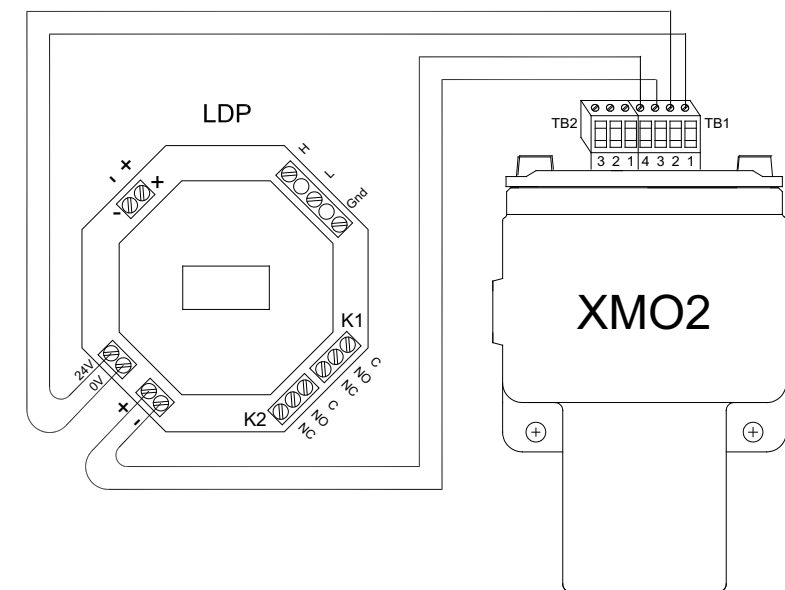

Figure 74: Interconnection Diagrams

Appendix C. IDM Menu Maps

This appendix includes the following IDM menu maps:

- Figure 75, “Field Cal, 4-20mA Output and Error Handler Menu Map,” on page 85

Appendix C.

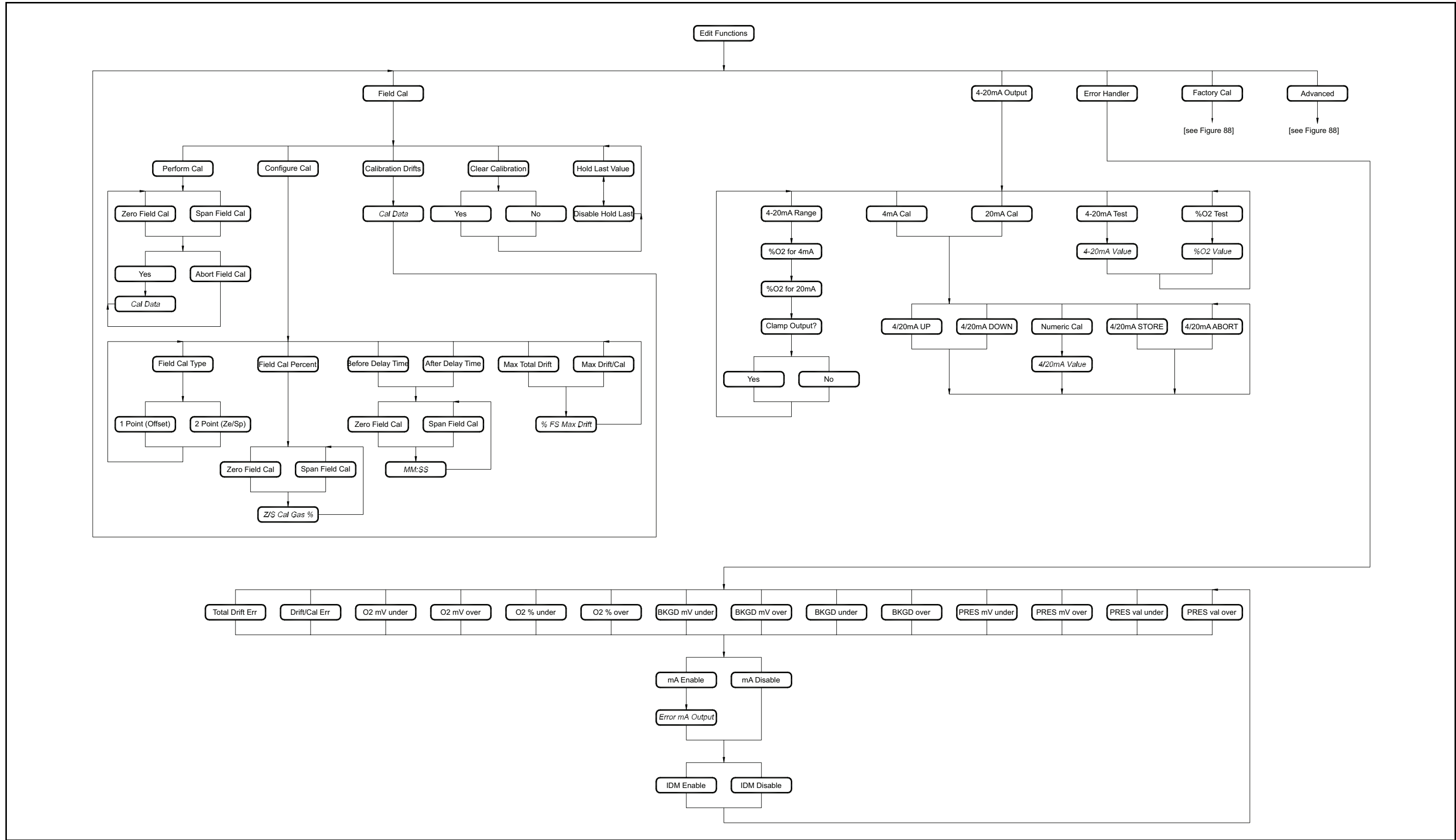

Figure 75: Field Cal, 4-20mA Output and Error Handler Menu Map

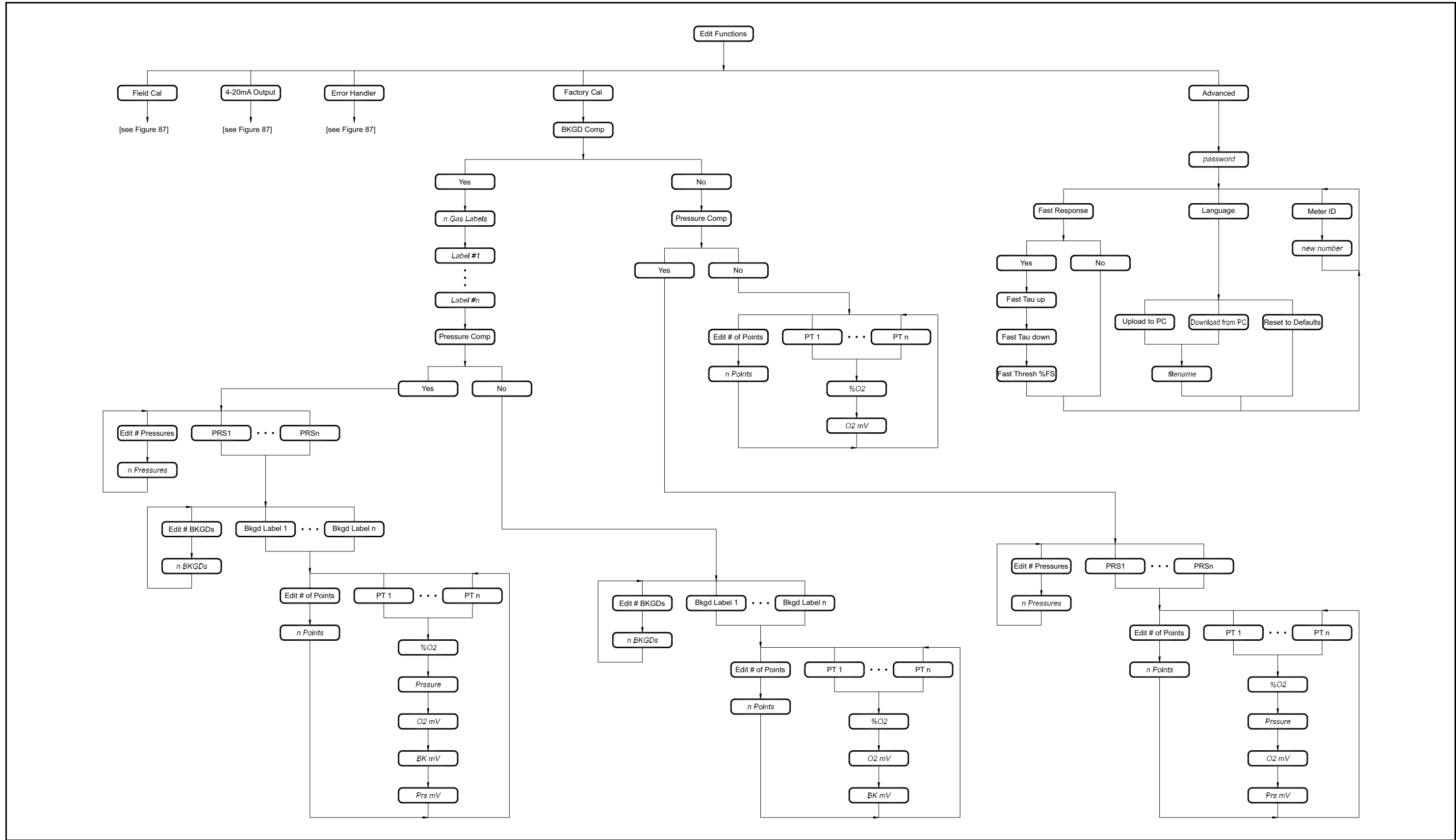

Figure 76: Factory Cal and Advanced Menu Map













Appendix D. Programming with PanaView

D.1 Introduction

The PanaView™ graphical user interface offers interactive communications between Windows-based PCs and Panametrics instruments compatible with IDM protocol, such as the XMO2 oxygen transmitter. [Compatible 32-bit Windows operating systems include Windows 98SE, NT 4.0 (with Service Pack 6), 2000, XP and ME.] With PanaView, you can:

- Load and save site file data
- Create and save graph and log files
- Display text output and graphs of live measurement data
- Create custom templates for displaying text, graph and log data
- Interface with multiple BH instruments.

This document focuses on particular applications suitable for the XMO2 transmitter. For general PanaView applications such as creating graph and log files, displaying live measurement data, and creating custom templates, please refer to the general PanaView *User's Manual* (910-211).

D.2 Wiring the RS232 Interface

All IDM-protocol instruments utilize an RS232 interface to communicate with a PC. For details on wiring your RS232 interface, refer to *Establishing the RS232 Communication Link* on page 16, and the Panametrics document *EIA-RS Serial Communications* (916-054).

D.3 Setting Up the Communications Port

Use the steps below to establish communications with the XMO2.

1. Open the "New Meter Browser" window and expand the network tree. Then, highlight the *My Computer (Name)* branch by clicking on it.
2. Pull down the "Edit" menu by clicking on it in the menu bar.
3. Click on the "New" menu option to open a submenu opens with two choices (see *Figure 77* below).

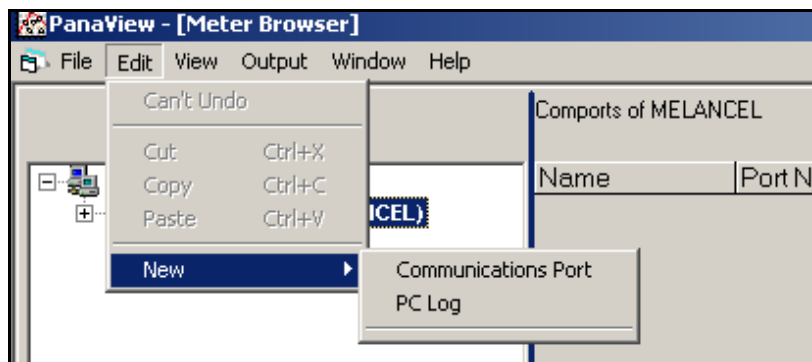

Figure 77: Edit Menu

4. Click on the "Communications Port" option to select it. The *Setup Communications* screen appears similar to *Figure 78* below.

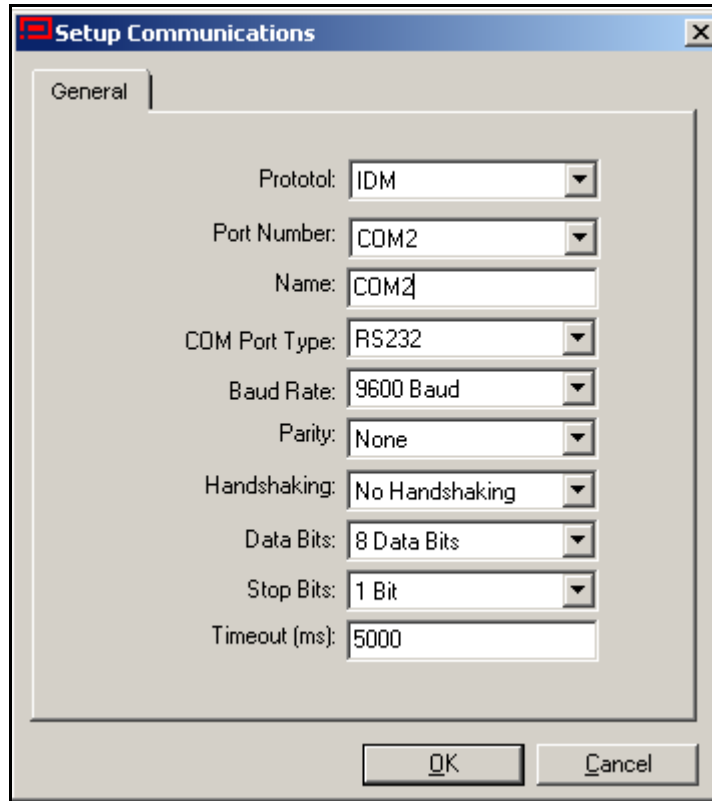

Figure 78: Setup Communications Screen

5. Open the Protocol menu (the first of the drop-down menus) and click on *IDM*.
6. Select any suitable available baud rate. A baud rate of 19200 is appropriate for almost all applications. However, if you experience periodic communication reliability problems, you may wish to consider lowering the baud rate on your instrument and in PandaView.

IMPORTANT: *Be sure all the communications port settings match those made in setting up the meter serial port.*

7. Click on [OK] to complete data entry.

D.1 Adding the XMO2

To add the XMO2 on the IDM-configured communications port, complete the following steps:

1. Highlight the communication port to which the meter will be added by clicking on it, and then open the "Edit" menu on the menu bar (if the communication port is not highlighted first, the "New Meter" option is not active in the "Edit" menu).
2. Click on the "New" option in the "Edit" menu (see Figure 79 below).

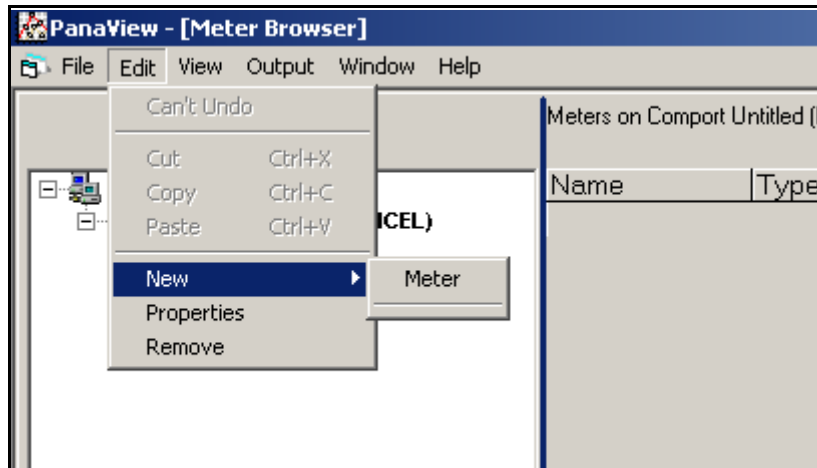

Figure 79: "New" Option in the "Edit" Menu

3. After clicking on the "New" option, the "Meter" menu option appears. Click on this option to select it.
4. The "New IDM Meter" screen (shown in Figure 80 below) opens. Enter the Network ID number for the meter, and click [OK].

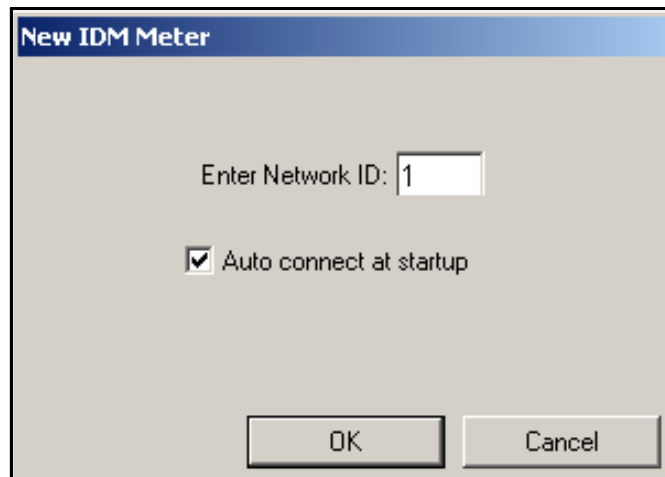

Figure 80: New IDM Meter Screen

IMPORTANT: The Network ID number must match the Network ID programmed in the meter Communications menu.

If the initialization is successful, the Meter Browser shows a listing similar to Figure 81 below.

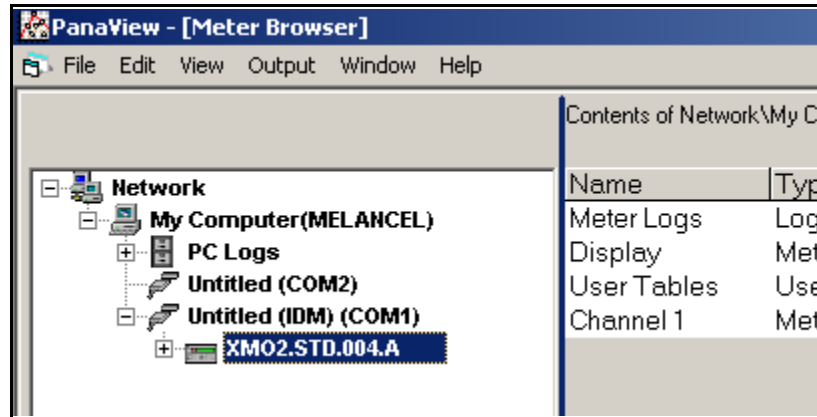

Figure 81: Updated Network Tree

However, if the settings do not match, or there is some other difficulty, a screen appears similar to *Figure 82* below.

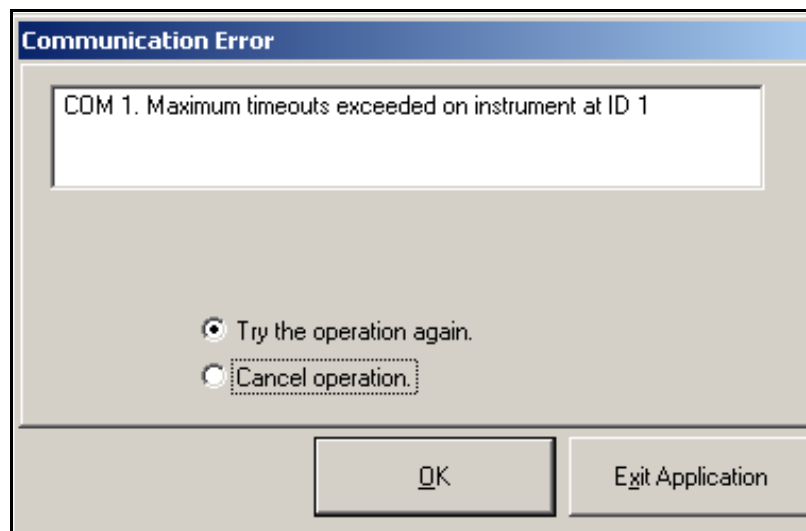

Figure 82: Communication Error Screen

The screen offers the options of trying again or of canceling the operation. Click on the desired choice, and then on [OK] to confirm the choice or on [Exit Application] to close PanaView.

IMPORTANT: *The Properties option in the Edit Menu is not applicable to the XMO2.*

D.1 Changing Meter Settings

Through PanaView, XMO2 users can handle remote programming of the meter. They can:

- Program and change a meter's operating parameters
- Set up, start, and stop logs
- Calibrate and test inputs and outputs
- Clear various files

To access the meter programming:

1. Enter the *New Meter Browser* option from the "File" menu.
2. Expand the network tree until you reach the desired meter.
3. Then expand the meter tree as shown in *Figure 83* below.

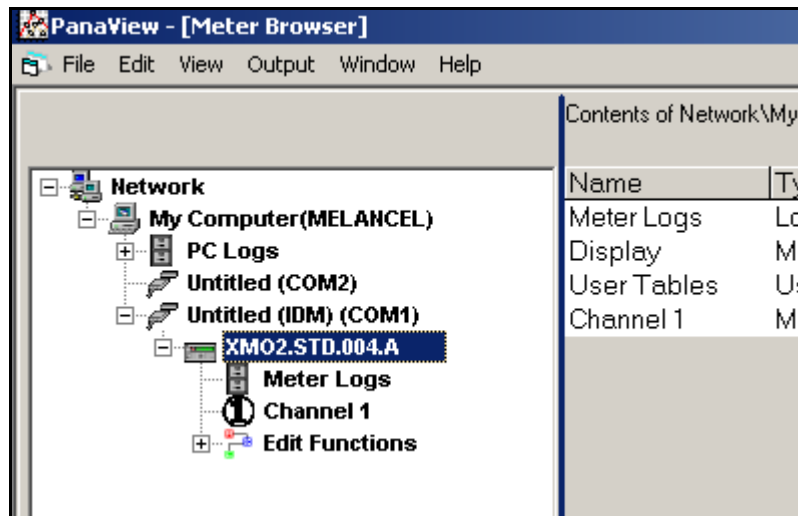

Figure 83: New Meter Browser with Meter Branch

4. From the meter tree, expand the *Edit Functions* option. The window now appears similar to *Figure 84* below, with a list of available menus. The five menus listed are those available through the IDM interface, as discussed in Chapters 3 and 4. Refer to the menu maps on *Figure 75* on page 85 and *Figure 76* on page 86 as a guide to programming.

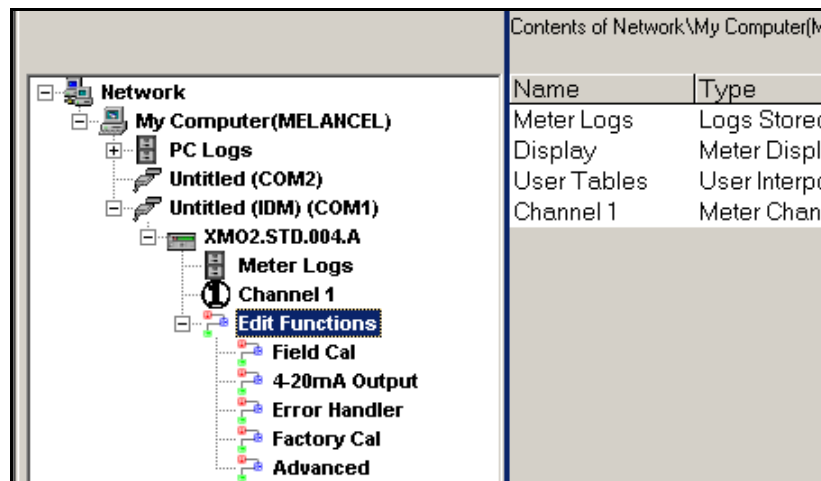

Figure 84: Meter Tree with *Edit Functions* Option

5. To open a particular menu, double-click on that menu on the tree. For example, if you double-click on the *Field Cal* menu, a window opens similar to *Figure 85* below.

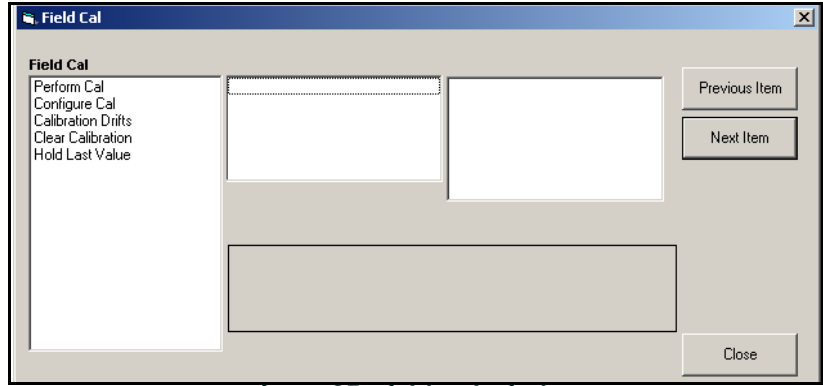

Figure 85: *Field Cal* Window

Note: For more information about the five menus, please refer to Chapter 3, Startup & Operation, and Chapter 4, Programming with Instrument Data Manager.

6. To enter a particular option:
 - a. Highlight and double-click on the desired option in the left pane. *Figure 86* below shows the first entry (*Perform Cal*) in the *Field Cal* option. The title above the center pane lists the current entry, while the center pane displays the available selections for that entry.
 - b. Click on the desired choice; if the entry requires a numeric value, change the value displayed in the right pane.

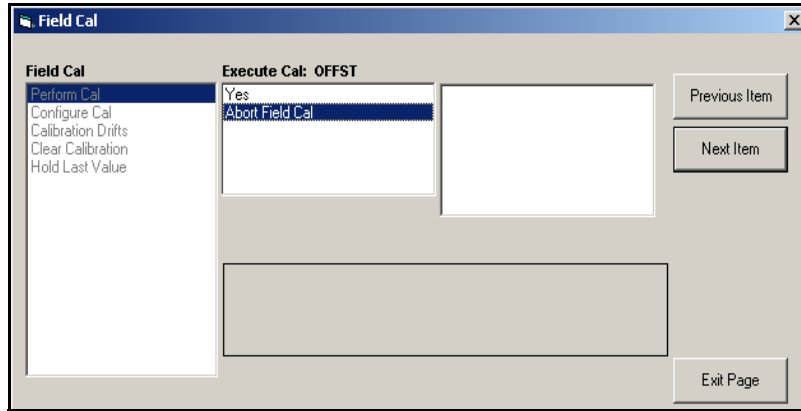

Figure 86: Perform Cal Option in the Field Cal Menu

- c. Do one of the following:
 - Click on [Next Item] to proceed to the next menu item,
 - or
 - Click on [Previous Item] to return back through the menu to a previous item.

Note: *If you click on either [Next Item] or [Previous Item] without changing the settings, the current settings remain unchanged.*

As you step through the menu, the bottom panel lists the current settings (modified or left unchanged), as shown in *Figure 87* below. If you modify or step through more than five items, a scroll bar at the right of the panel lets you review the earlier settings.

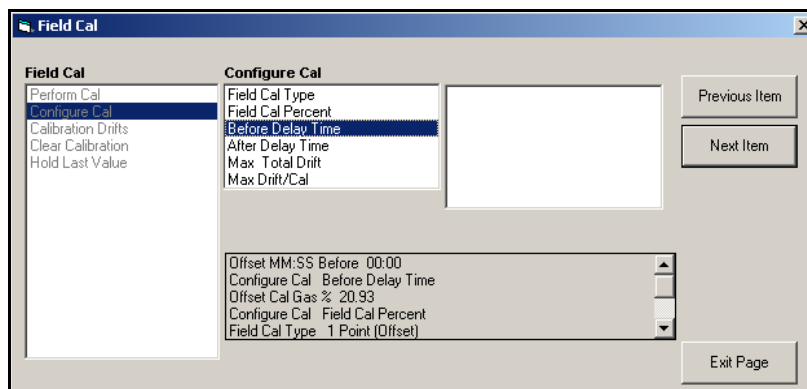

Figure 87: Field Cal Menu with Current Settings

7. When you have completed entering parameters in a given option, click [Exit Page] to close the option. You can then double-click on another option, or click [Close] to close the window.

You can double-click on another menu to modify its settings, or return to the *New Meter Browser*. For additional PanaView functions, refer to the *PanaView User's Manual*.

Appendix E. CE Mark Compliance

E.1 CE Mark Requirements



WARNING! CE Mark compliance is required for all units installed in EU countries.



WARNING! To meet CE Mark requirements, you must shield and ground all electrical cables as described in this section (see *Table 5* below).

Note: If you follow the instructions in this section, your unit will comply with the EMC Directive.

Table 5: Wiring Requirements for CE Mark Compliance

Connection	Termination Modification
Power/Analog Output	<ol style="list-style-type: none"> 1. When connecting the line power/analog output cable, select the cable entry closest to the terminal blocks. 2. Use shielded cable* to connect the line power and the 4-20mA analog output device to the XMO2. It is recommended to use Panametrics P/N X4(*) or equivalent for all weatherproof installation, and Panametrics P/N Z4(*) or equivalent for all explosion/flameproof installation. 3. Terminate the shield to the cable gland. It is recommended to use Panametrics P/N 419-215 or equivalent for all weatherproof installation and Panametrics P/N 419-217 or equivalent for all explosion/flameproof installation.
RS232 Output	<ol style="list-style-type: none"> 1. Use shielded cable* to interconnect the XMO2 enclosure with any external I/O devices. It is recommended to use Panametrics P/N 704-668-12 or equivalent for all weatherproof installation and Panametrics P/N 704-1262-12 or equivalent for all explosion/flameproof installation. 2. Terminate the shield to the cable gland. It is recommended to use Panametrics P/N 419-215 or equivalent for all weatherproof installation and Panametrics P/N 419-217 or equivalent for all explosion/flameproof installation.
*Wires enclosed in a properly-grounded metal conduit do not require additional shielding.	



WARNING! Cable entries of an approved flameproof design are required. These must be installed according to the manufacturer's instructions. The choice of cable entry device may limit the overall installation category achieved.



WARNING! It is the responsibility of the user to ensure that all cable entry devices and covers are properly installed and secure prior to applying power to the XMO2.

E.1 EMI Filter Board

For CE compliance, an *EMI filter board* has been added to the XMO2 (see *Figure 88* below). This board is connected internally to terminal block **TB1**. The *power* and *analog output* connections are now made to terminal block **TB3** on the EMI filter board. The RS232 *digital output* connections are made to terminal block **TB2**.



CAUTION! Do not make any connections to unassigned or unused terminals.

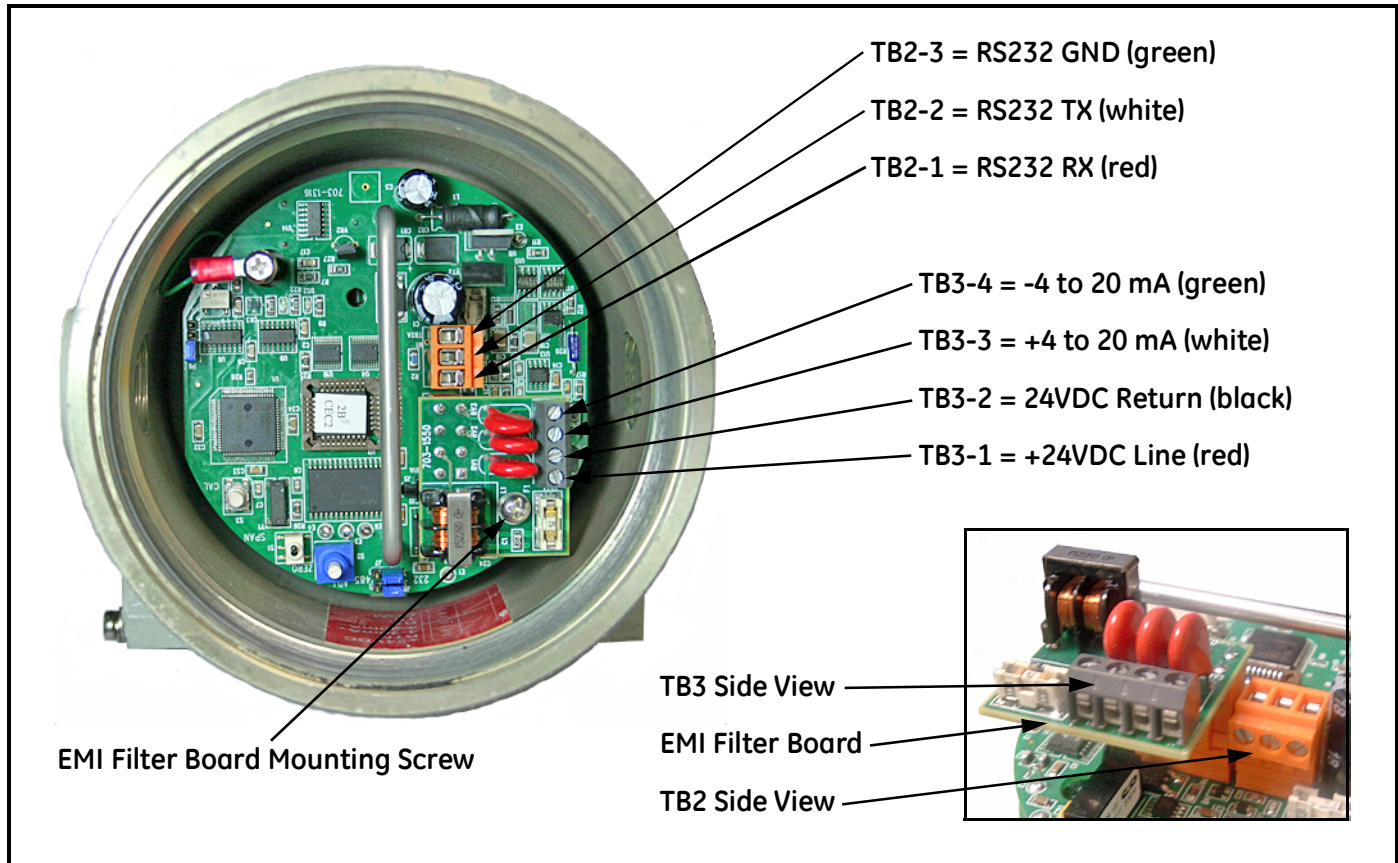

Figure 88: XMO2 with EMI Filter Board - Wiring Connections

E.2 Wiring the Signal Connections for the Weatherproof Version

Refer to *Figure 88* on page 102, and complete the following steps to make the proper wiring connections:



WARNING! Cable entries of an approved flameproof design are required. These must be installed according to the manufacturer's instructions. The choice of cable entry device may limit the overall installation category achieved.

1. Install the first cable entry device in accordance with the manufacturer's instructions.

Note: If installation of the cable entry device is only partially complete, Panametrics recommends tagging the device to ensure the safety of subsequent users.

- a. Thread the cable gland entry body into the XMO2 port closest to the terminal blocks.
- b. Route the 4-wire power/analog output cable through the cable gland as shown in *Figure 89* below.
- c. After terminating the shield as shown, assemble the three gland pieces together and tighten the gland to secure the cable and the shield.

IMPORTANT: The cable shield must be terminated in the cable gland as shown in *Figure 89* below.

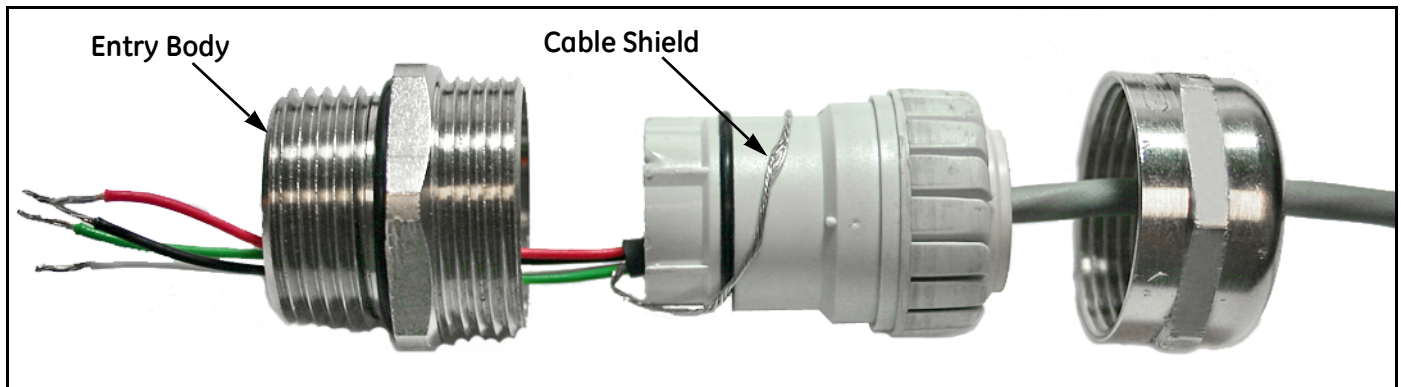

Figure 89: Proper Cable Gland Assembly (Panametrics p/n 419-215)

2. Remove the screw that secures the EMI filter board to its standoff. Then, pull the board from its socket to access the TB3 connector, and loosen the terminal screws on the TB3 connector.
3. Connect the power leads:



CAUTION! Connecting the +24 VDC line (red) lead to any terminal except TB3-1 will damage the XMO2.

- a. Insert the 4-wire cable +24 VDC line (red) lead into pin TB3-1 and tighten the screw.
 - b. Insert the 4-wire cable 24 VDC return (black) lead into pin TB3-2 and tighten the screw.
4. Connect the analog output leads:
 - a. Insert the 4-wire cable + 4-20 mA (white) lead into pin TB3-3 and tighten the screw.
 - b. Insert the 4-wire cable - 4-20 mA (green) lead into pin TB3-4 and tighten the screw.
 5. Carefully plug the EMI filter board back into its socket, and screw the EMI filter board to its standoff.
 6. If you are installing the second cable entry device, do so in accordance with the manufacturer's instructions.

Note: If installation of the cable entry device is only partially complete, Panametrics recommends tagging the device to ensure the safety of subsequent users.

- a. Thread the cable gland entry body into the remaining XMO2 port.
- b. Route the 3-wire RS232 cable through the cable gland as shown in *Figure 89 on page 103*.
- c. After terminating the shield as shown, assemble the three gland pieces together and tighten the gland to secure the cable and the shield.

IMPORTANT: *The cable shield must be terminated in the cable gland as shown in Figure 89 on page 103.*

7. Unplug the TB2 connector by pulling it straight out of its socket, and loosen the terminal screws on the TB2 connector.
8. Connect the RS232 serial port leads:
 - a. Insert the 3-wire cable RX (red) lead into pin TB2-1 and tighten the screw.
 - b. Insert the 3-wire cable TX (white) lead into pin TB2-2 and tighten the screw.
 - c. Insert the 3-wire cable GND (green) lead into pin TB2-3 and tighten the screw.
9. Carefully plug the TB2 connector into its socket.
10. Reinstall the cover on the XMO2.
11. Connect the other ends of the cables to the 24 VDC power supply, the 4-20 mA input of the display device, and the serial port of the computer or terminal (see the instruction manuals for those devices for details).

E.1 Wiring the Signal Connections for the Explosion/Flameproof Version

Refer to *Figure 88* on page 102, and complete the following steps to make the proper wiring connections:



WARNING! Cable entries of an approved flameproof design are required. These must be installed according to the manufacturer's instructions. The choice of a cable entry device may limit the overall installation category achieved.

1. Install the first cable entry device in accordance with the manufacturer's instructions.

Note: If installation of the cable entry device is only partially complete, Panametrics recommends tagging the device to ensure the safety of subsequent users.

- a. Remove the tab "Remove Before Installation".
- b. Thread the cable gland entry body into the XMO2 port closest to the terminal blocks.
- c. Route the 4-wire power/analog output cable & its ground lug through the cable gland.
- d. Fray the braided shield and spread evenly around the cone as shown in *Figure 90* below. Compress the ring to lock the shield.
- e. After terminating the shield as shown, assemble the gland pieces together and tighten the gland to secure the cable and the shield.

IMPORTANT: The cable shield must be terminated in the cable gland as shown in *Figure 90* below.

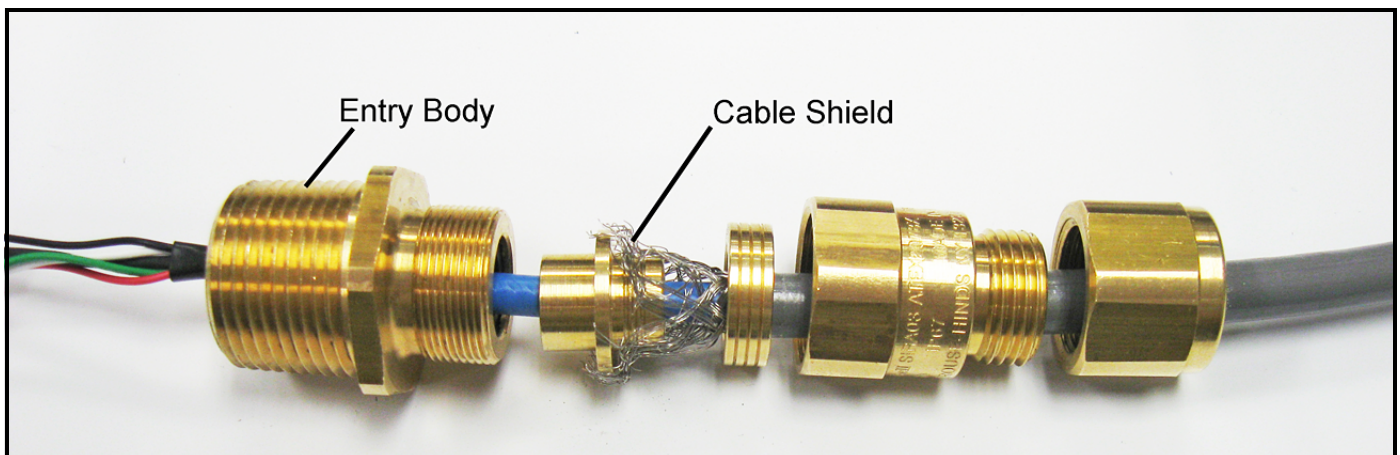

Figure 90: Proper Cable Gland Assembly (Panametrics p/n 419-217)

2. Remove the standoff and the screw that secures the EMI filter board to its standoff. Then, pull the board from its socket to access the TB3 connector, and loosen the terminal screws on the TB3 connector.
3. Connect the power leads:



CAUTION! Connecting the +24 VDC line (red) lead to any terminal except TB3-1 will damage the XMO2.

- a. Insert the 4-wire cable +24 VDC line (red) lead into pin TB3-1 and tighten the screw.
 - b. Insert the 4-wire cable 24 VDC return (black) lead into pin TB3-2 and tighten the screw.
4. Connect the analog output leads:
 - a. Insert the 4-wire cable + 4-20 mA (white) lead into pin TB3-3 and tighten the screw.

- b.** Insert the 4-wire cable - 4-20 mA (green) lead into pin TB3-4 and tighten the screw.
- 5. Plug the EMI board back into its socket and secure it with the standoff. Terminate the ground lug of the cable to the standoff and secure it with the provided screw.
- 6. If you are installing the second cable entry device, do so in accordance with the manufacturer's instructions.

Note: *If installation of the cable entry device is only partially complete, Panametrics recommends tagging the device to ensure the safety of subsequent users.*

- a.** Remove the tab "Remove Before Installation".
 - b.** Thread the cable gland entry body into the remaining XMO2 port.
 - c.** Route the 3-wire RS232 cable & its ground lug through the cable gland.
 - d.** Fray the braided shield and spread evenly around the cone as shown in Figure 90 on page 105. Compress the ring to lock the shield.
 - e.** After terminating the shield as shown, assemble the gland pieces together and tighten the gland to secure the cable and the shield.

IMPORTANT: *The cable shield must be terminated in the cable gland as shown in Figure 90 on page 105.*

- 7. Unplug the TB2 connector by pulling it straight out of its socket, and loosen the terminal screws on the TB2 connector.
- 8. Connect the RS232 serial port leads:
 - a.** Insert the 3-wire cable RX (red) lead into pin TB2-1 and tighten the screw.
 - b.** Insert the 3-wire cable TX (white) lead into pin TB2-2 and tighten the screw.
 - c.** Insert the 3-wire cable GND (green) lead into pin TB2-3 and tighten the screw.
- 9. Carefully plug the TB2 connector back into its sockets. Terminate the ground lug to the nearest standoff.
- 10. Reinstall the cover on the XMO2.
- 11. Connect the other ends of the cables to the 24 VDC power supply, the 4-20 mA input of the display device, and the serial port of the computer or terminal (see the instruction manuals for those devices for details).

Appendix F. Certifications

F.1 EC-Type Examination Certificate

	
<p>1. EC-TYPE EXAMINATION CERTIFICATE</p>	
<p>2. Equipment or Protective System Intended for use in Potentially Explosive Atmospheres Directive 94/9/EC</p>	
<p>3. EC-Type Examination Certificate Number:</p>	<p>ITS12ATEX17703X</p>
<p>4. Equipment or Protective System:</p>	<p>XMTC Gas Analyser and XMO2 Oxygen Analyser</p>
<p>5. Manufacturer:</p>	<p>GE Infrastructure Sensing</p>
<p>6. Address:</p>	<p>1100 Technology Park Drive, Billerica, MA, 01821</p>
<p>7. This equipment or protective system and any acceptable variation thereto is specified in the schedule to this certificate and the documents therein referred to.</p>	
<p>8. Intertek Testing and Certification Limited, notified body number 0359 in accordance with Article 9 of the Council Directive 94/9/EC of 23 March 1994, certifies that this equipment or protective system has been found to comply with the Essential Health and Safety Requirements relating to the design and construction of equipment and protective systems intended for use in potentially explosive atmospheres given in Annex II to the Directive.</p>	
<p>The examination and test results are recorded in confidential Intertek Report Ref 100911958MAN-001 dated July 2013.</p>	
<p>9. Compliance with the Essential Health and Safety Requirements has been assured by compliance with standards EN 60079-0:2012 and EN 60079-1:2007 except in respect of those requirements referred to at item 18 of the Schedule.</p>	
<p>10. If the sign "X" is placed after the certificate number, it indicates that the equipment or protective system is subject to special conditions for safe use specified in the schedule to this certificate.</p>	
<p>11. This EC-Type examination certificate relates only to the design and construction of the specified equipment or protective system in accordance to the directive 94/9/EC. Further requirements of the Directive apply to the manufacturing process and supply of this equipment or protective system. These are not covered by this certificate.</p>	
<p>12. The marking of the equipment or protective system shall include the following:-</p>	
	<p>II 2 G Ex d IIC T6 Gb (Tamb: -20°C to +65°C) for the XMTC (Tamb: -20°C to +55°C) for the XMO2</p>
<p>Intertek Testing & Certification Limited Intertek House, Cleeve Road, Leatherhead, Surrey, KT22 7SB Tel: +44 (0)1372 370900 Fax: +44 (0)1372 370977 www.intertek.com Registered No 3272281 Registered Office: Academy Place, 1-9 Brook Street, Brentwood, Essex, CM14 5NQ.</p>	
<p> K R Spence Certification Officer 26 July 2013</p>	
<p>This certificate may only be reproduced in its entirety and without any change, schedule included and is subject to Intertek Testing and Certification's Conditions for Granting Certification.</p>	
<p>Sheet 1 of 3</p>	
<p>FxF-300 - FC Type Examination Certificate</p>	<p>Template Revision 4</p>
<p>June 2013</p>	

Figure 91: EC-Type Examination Certificate (Sheet 1 of 3)





	
<p>SCHEDULE</p>	
<p>EC-TYPE EXAMINATION CERTIFICATE NUMBER ITS12ATEX17703X</p>	
<p>15. Description of Equipment or Protective System</p>	<p>The XMTC and XMO2 are cylindrical flameproof enclosures that can be made from either stainless steel or a powder coated aluminium alloy. The equipment is approximately 140 mm in diameter and approximately 210mm from base to lid, excluding the protrusions used for opening and closing the enclosure and the flame arrestors on the bottom. The flame arrestors are certified and covered by certificate number ITS12ATEX90013U.</p> <p>The XMTC measures the concentration of a gas in a binary gas mixture by measuring the thermal conductivity of the sample gas and comparing it to the thermal conductivity of a selected reference gas. The XMO2 measures the concentration of oxygen in a gas mixture by utilizing the unique paramagnetic properties of oxygen. Both models utilise 3/4" NPT entries into the enclosures.</p> <p>The equipment is earthed internally and externally via screwed earthing connections and are clearly marked on the enclosures. Both the XMO2 and the XMTC are rated 24Vdc, 25 Watts.</p>
<p>16. Report Number</p>	<p>Intertek Report Ref: 100911958MAN-001 dated: July 2013</p>
<p>17. Conditions of Certification</p>	<p>(a). Special Conditions for safe use</p> <ul style="list-style-type: none"> • Only suitably approved Ex d IIC Gb cable glands and blanking elements suitable for the ambient temperature range shall be used. • No modifications must be made to the flamepaths of the unit without consultation of the manufactures drawings. <p>(b). Conditions of Manufacture</p> <ul style="list-style-type: none"> • None
<p>18. Essential Health and Safety Requirements (EHSR's)</p>	<p>The relevant EHSR's have been identified and assessed in Intertek Report Ref: 100911958MAN-001 dated July 2013</p>
<p style="text-align: center;">Intertek Testing & Certification Limited Intertek House, Cleeve Road, Leatherhead, Surrey, KT22 7SB Tel: + 44 (0)1372 370900 Fax: +44 (0)1372 370977 www.intertek.com Registered No 3272281 Registered Office: Academy Place, 1-9 Brook Street, Brentwood, Essex, CM14 5NQ.</p>	
<p style="text-align: center;">This Certificate is the property of Intertek Testing and Certification Ltd and is subject to Intertek Testing and Certification's Conditions for Granting Certification.</p>	
<p>Sheet 2 of 3</p>	
<p>ExF-300 - EC Type Examination Certificate</p>	<p>Template Revision 4</p>
<p>June 2013</p>	

Figure 92: EC-Type Examination Certificate (Sheet 2 of 3)

			
SCHEDULE			
EC-TYPE EXAMINATION CERTIFICATE NUMBER ITS12ATEX17703X			
19. Drawings and Documents			
Number	Title	Issue	Date
752-168	Certification Drawing XMO2, XMTC (Sheets 1 to 4)	E	12/1/12
910-141	Certification & Safety Statements for the XMO2 Oxygen Analyser (Sheets 1 & 2)	A	May 2013
CSS-0006	Certification & Safety Statements for the XMTC Gas Analyser (Sheets 1 & 2)	A	May 2013

This Certificate is for the exclusive use of Intertek's client and is provided pursuant to the agreement between Intertek and its Client. Intertek's responsibility and liability are limited to the terms and conditions of the agreement. Intertek assumes no liability to any party, other than to the Client in accordance with the agreement, for any loss, expense or damage occasioned by the use of this Certificate. Only the Client is authorized to permit copying or distribution of this Certificate and then only in its entirety. Any use of the Intertek name or one of its marks for the sale or advertisement of the tested material, product or service must first be approved in writing by Intertek.

Intertek Testing & Certification Limited
Intertek House, Cleeve Road, Leatherhead, Surrey, KT22 7SB
Tel: + 44 (0)1372 370900 Fax: +44 (0)1372 370977
www.intertek.com
Registered No 3272281 Registered Office: Academy Place, 1-9 Brook Street, Brentwood, Essex, CM14 5NQ.

This Certificate is the property of Intertek Testing and Certification Ltd and is subject to Intertek Testing and Certification's Conditions for Granting Certification.

Sheet 3 of 3

EXF-300 - EC Type Examination Certificate Template Revision 4 June 2013

Figure 93: EC-Type Examination Certificate (Sheet 3 of 3)

F.2 IECEx Certificate of Conformity



		<h1>IECEX Certificate of Conformity</h1>	
INTERNATIONAL ELECTROTECHNICAL COMMISSION IEC Certification Scheme for Explosive Atmospheres <small>for rules and details of the IECEx Scheme visit www.iecex.com</small>			
Certificate No.:	IECEX ITS 12.0058X	issue No.:0	Certificate history:
Status:	Current		
Date of Issue:	2013-07-23	Page 1 of 3	
Applicant:	GE Infrastructure Sensing 1100 Technology Park Drive Billerica, MA, 01821 United States of America		
Electrical Apparatus:	XMTc and XMO2		
Optional accessory:			
Type of Protection:	Flameproof 'Ex d', Protection by Enclosure		
Marking:	XMTc = Ex d IIC T6 Gb (T _{amb} -20°C to +65°C) XMO2 = Ex d IIC T6 Gb (T _{amb} -20°C to +55°C)		
	IECEX ITS 12.0058X		
Approved for issue on behalf of the IECEx Certification Body:	K R Spence		
Position:	Certification officer		
Signature: (for printed version)			
Date:			
	1. This certificate and schedule may only be reproduced in full. 2. This certificate is not transferable and remains the property of the issuing body. 3. The Status and authenticity of this certificate may be verified by visiting the Official IECEx Website .		
Certificate issued by:	Intertek Testing & Certification Limited ITS House, Cleeve Road, Leatherhead, Surrey, KT22 7SB United Kingdom		
			

Figure 94: EC-Type Examination Certificate (Page 1 of 3)

IEC		IECEX		<h1>IECEX Certificate of Conformity</h1>	
Certificate No.:	IECEX ITS 12.0058X				
Date of Issue:	2013-07-23	Issue No.:	0		
			Page 2 of 3		
Manufacturer:	GE Infrastructure Sensing 1100 Technology Park Drive Billerica, MA,01821 United States of America				
Additional Manufacturing location (s):	GE Sensing EMEA Unit A/B Shannon Free Zone East Shannon County Clare Ireland Ireland				
<p>This certificate is issued as verification that a sample(s), representative of production, was assessed and tested and found to comply with the IEC Standard list below and that the manufacturer's quality system, relating to the Ex products covered by this certificate, was assessed and found to comply with the IECEX Quality system requirements. This certificate is granted subject to the conditions as set out in IECEX Scheme Rules, IECEX 02 and Operational Documents as amended.</p>					
STANDARDS:					
The electrical apparatus and any acceptable variations to it specified in the schedule of this certificate and the identified documents, was found to comply with the following standards:					
IEC 60079-0 : 2011	Explosive atmospheres - Part 0: General requirements				
Edition: 6.0					
IEC 60079-1 : 2007-04	Explosive atmospheres - Part 1: Equipment protection by flameproof enclosures "d"				
Edition: 6					
<i>This Certificate does not indicate compliance with electrical safety and performance requirements other than those expressly included in the Standards listed above.</i>					
TEST & ASSESSMENT REPORTS:					
A sample(s) of the equipment listed has successfully met the examination and test requirements as recorded in					
<u>Test Report:</u>					
GB/ITS/ExTR12.0059/00					
<u>Quality Assessment Report:</u>					
GB/BAS/QAR06.0025/04			GB/BAS/QAR10.0026/01		

Figure 95: EC-Type Examination Certificate (Page 2 of 3)

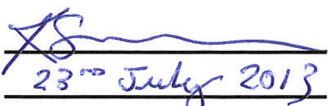
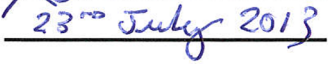
		<h2 style="margin: 0;">IECEX Certificate of Conformity</h2>	
Certificate No.:	IECEX ITS 12.0058X	Issue No.:	0
Date of Issue:	2013-07-23	Page 3 of 3	
Schedule			
EQUIPMENT:			
<i>Equipment and systems covered by this certificate are as follows:</i>			
<p>The XMTC and XMO2 are cylindrical flameproof enclosures that can be made from either stainless steel or a powder coated aluminium alloy. The equipment is approximately 140 mm in diameter and approximately 210mm from base to lid, excluding the protrusions used for opening and closing the enclosure and the flame arrestors on the bottom. The flame arrestors are certified and covered by certificate number IECEXINE12.0002U.</p> <p>The XMTC measures the concentration of a gas in a binary gas mixture by measuring the thermal conductivity of the sample gas and comparing it to the thermal conductivity of a selected reference gas. The XMO2 measures the concentration of oxygen in a gas mixture by utilizing the unique paramagnetic properties of oxygen. Both models utilise 3/4" NPT entries into the enclosures. The equipment is earthed internally and externally via screwed earthing connections and are clearly marked on the enclosures. Both the XMO2 and the XMTC are rated 24Vdc, 25 Watts.</p>			
CONDITIONS OF CERTIFICATION: YES as shown below:			
<ul style="list-style-type: none"> ■ Only suitably approved Ex d IIC Gb cable glands and blanking elements suitable for the ambient temperature range shall be used. ■ No modifications must be made to the flamepaths of the unit without consultation of the manufactures drawings. 			
<p>Annex: Annex to IECEX ITS 12. 0058X issue 0.doc</p>			

Figure 96: EC-Type Examination Certificate (Page 3 of 3)

A		E	
Accessories, Optional	59	EC-Type Examination Certificate	107
Ambient Temperature Range	58	Edit Functions Option	97
Analog Output		Edit Menu	93
Calibration Options	21	EMC Directive	101
Changing the Range	38	EMI Filter Board	102
Specifications	57	Enhancing Factory Calibration	22
Applications		Environmental	
Blanketing Gases in HC Storage Tanks	63	Specifications	59
Formaldehyde Reactor Feed Gases	65	Environmental Compliance	iv
ATEX Certification	107		
B		F	
Background Gas Compensation	21	Factory Calibration	
Bridge Circuit	4	Enhancing	22
		Range	21
C		Filter Board, EMI	102
Cable		Flow Rate	
Entry Devices	101	Offset Gas	26
Specifications	57	Sample Gas	19
Cables		Span Gas	28
Length	7	Zero Gas	28
Signal	13	Flow Rate, Gas	57
Specifications	13	Flow Schematic	2
Calibration			
Analog Output Options	21	G	
Data Sheet	62	Gas	
Enhancing	22	Flow Rates	57
Factory Range	21	Gases	
Frequency	23	Calibration	24
Gases	24	Offset	24
Offset	26	Span	24
One-Gas	26	Zero	24
Pushbutton	26		
Required Materials	24	I	
RS232 Port, Initial	29	IECEx Certificate of Conformity	110
Span Gas, Pushbutton	28	Information Paragraphs	iii
Switches	25	Installation	
Two-Gas, Pushbutton	27	Drawings	67
Zero Gas, Pushbutton	28	Sample System	10
Calibration Data Sheet	62	Transmitter	9
CE Mark Compliance	101		
Certifications		M	
ATEX Certification	107	Materials for Calibration	24
EC-Type Examination Certificate	107	Measurement Ranges	57
IECEx Certificate of Conformity	110	Menus, Edit	93
Changing the Analog Output Range	38	Meter Settings, Changing	97
Communications Port, Setting Up	93		
Compensation		O	
Background Gas	21	Offset Calibration	26
Pressure	21	One-Gas Calibration	26
		Operating Temperature	57
D		Ordering Information	59
Data Sheet, Calibration	62		
Date of Publication	i	P	
Dimensions	59	PanaView, Applications of	93
Display		Power Specifications	57
Available Options	17	Power Supply	
Wiring	17	Description	7
Document Number	i	Wiring	17
Drawings, Installation & Wiring	67	Powering Up	19

Pressure Compensation	21
Pushbutton Calibration	26

R

Range	
Changing	38
Factory Calibration	21
Ranges, Measurement	57
Return Policy	115
RS232 Port	
Configuring	16
Initial Calibration	29

S

Safety	
Auxiliary Equipment	iii
General Issues	iii
Personal Equipment	iii
Sample Gas	
Flow Rate	19
Initiating Flow	19
Sample System	
Description	7
Installation	10
Signal Connections	15
CE Wiring	103
Span Gas	
Calibration, Pushbutton	28
Specifications	
Environmental	59
Switches	
Calibration	25

T

Terminal Block TBI	14
Theory of Operation	2
Thermistors	3
TMO2D Display	7
Two-Gas Calibration	
Pushbutton	27

W

Warranty	115
WEEE Directive	iv
Weight	59
Wiring	
CE Signal Connections	103
Display	17
Drawings	67
Power Supply	17
Signal Connections	15
Terminal Block TBI	14

X

XMO2	
Accessories	59
Cable	13
Installation	9
Ordering Information	59
Overview	1
Powering Up	19
System Components	5
Theory of Operation	2
Transmitter Features	5

Z

Zero Gas	
Pushbutton Calibration	28

Warranty

Each instrument manufactured by Panametrics Sensing is warranted to be free from defects in material and workmanship. Liability under this warranty is limited to restoring the instrument to normal operation or replacing the instrument, at the sole discretion of Panametrics Sensing. Fuses and batteries are specifically excluded from any liability. This warranty is effective from the date of delivery to the original purchaser. If Panametrics Sensing determines that the equipment was defective, the warranty period is:

- one year from delivery for electronic or mechanical failures
- one year from delivery for sensor shelf life

If Panametrics Sensing determines that the equipment was damaged by misuse, improper installation, the use of unauthorized replacement parts, or operating conditions outside the guidelines specified by Panametrics Sensing, the repairs are not covered under this warranty.

The warranties set forth herein are exclusive and are in lieu of all other warranties whether statutory, express or implied (including warranties or merchantability and fitness for a particular purpose, and warranties arising from course of dealing or usage or trade).

Return Policy

If a Panametrics Sensing instrument malfunctions within the warranty period, the following procedure must be completed:

1. Notify Panametrics Sensing, giving full details of the problem, and provide the model number and serial number of the instrument. If the nature of the problem indicates the need for factory service, Panametrics Sensing will issue a RETURN AUTHORIZATION NUMBER (RAN), and shipping instructions for the return of the instrument to a service center will be provided.
2. If Panametrics Sensing instructs you to send your instrument to a service center, it must be shipped prepaid to the authorized repair station indicated in the shipping instructions.
3. Upon receipt, Panametrics Sensing will evaluate the instrument to determine the cause of the malfunction.

Then, one of the following courses of action will then be taken:

- If the damage is covered under the terms of the warranty, the instrument will be repaired at no cost to the owner and returned.
- If Panametrics Sensing determines that the damage is not covered under the terms of the warranty, or if the warranty has expired, an estimate for the cost of the repairs at standard rates will be provided. Upon receipt of the owner's approval to proceed, the instrument will be repaired and returned.

[no content intended for this page]

Certification & Safety Statements for the XMO2 Oxygen Analyzer

When installing this apparatus, the following requirements must be met:

- Field wiring shall be rated at least 10°C above 65°C.
- Connecting cables shall be mounted securely and protected from mechanical damage, pulling and twisting.
- Cable entries are ¾" NPT.
- Cable glands of an approved flameproof design, ATEX + IECEx rated Ex d IIC are required. These must be installed according to the manufacturer's instructions. Where the cable glands are provided by Panametrics, the manufacturer's instructions, as supplied, to Panametrics, will be included in the documentation.
- Unused entries must be sealed using a certified, ATEX + IECEx rated Ex d IIC, threaded plug.
- Modifications to the flameproof enclosure are not permitted.
- The apparatus should be de-energized before opening.
- Installation should comply with IEC/EN 60079-14.
- Equipment is of type flameproof "d" design and complies with: EN 60079-0:2012, EN 60079-1:2007, EN 60529:1991 +A1:2000, IEC 60079-0:2011, IEC 60079-1:2007, IEC 60529:2001.
- The product contains no exposed parts which produce surface temperature infrared, electromagnetic ionizing, or non-electrical dangers.
- The product must not be subjected to mechanical or thermal stresses in excess of those permitted in the certification documentation and the instruction manual.
- The product cannot be repaired by the user; it must be replaced by an equivalent certified product. Repairs should only be carried out by the manufacturer or by an approved repairer.
- Only trained, competent personnel may install, operate and maintain the equipment.
- Replacement of Cells or Batteries is not permitted by the end user.
- The Battery is protected from Stray Voltage by the Microprocessor Supervisory Circuit (see image to right).
- The product is an electrical apparatus and must be installed in the hazardous area in accordance with the requirements of the EC Type Examination Certificate. The installation must be carried out in accordance with all the appropriate international, national and local standard codes and practices and site regulations for flameproof apparatus and in accordance with the instructions contained in the manual. Access to the circuitry must not be made during operation.

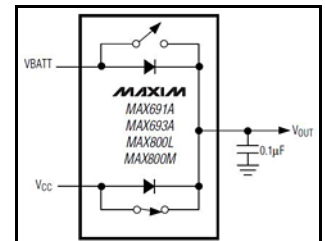

Special Conditions for Safe Use

- Consult the manufacturer if dimensional information on the flameproof joints is necessary.

Markings

- Markings shall appear on the product as shown below:

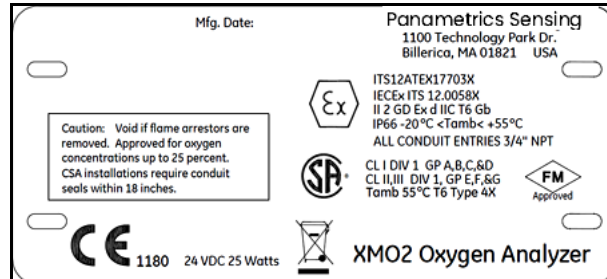

Customer Support Centers

U.S.A.

The Boston Center
1100 Technology Park Drive
Billerica, MA 01821
U.S.A.

Tel: 800 833 9438 (toll-free)
978 437 1000

E-mail: panametricstechsupport@bakerhughes.com

Ireland

Sensing House
Shannon Free Zone East
Shannon, County Clare
Ireland

Tel: +353 61 61470200

E-mail: panametricstechsupport@bakerhughes.com

Copyright 2023 Baker Hughes company.
This material contains one or more registered
trademarks of Baker Hughes Company and its
subsidiaries in one or more countries. All third-party
product and company names are trademarks of their
respective holders.

BH056C11 EN H (05/2023)

Baker Hughes 