

Masoneilan™ 39004 Series

High Performance Butterfly Valve

Instruction Manual (Rev.B)

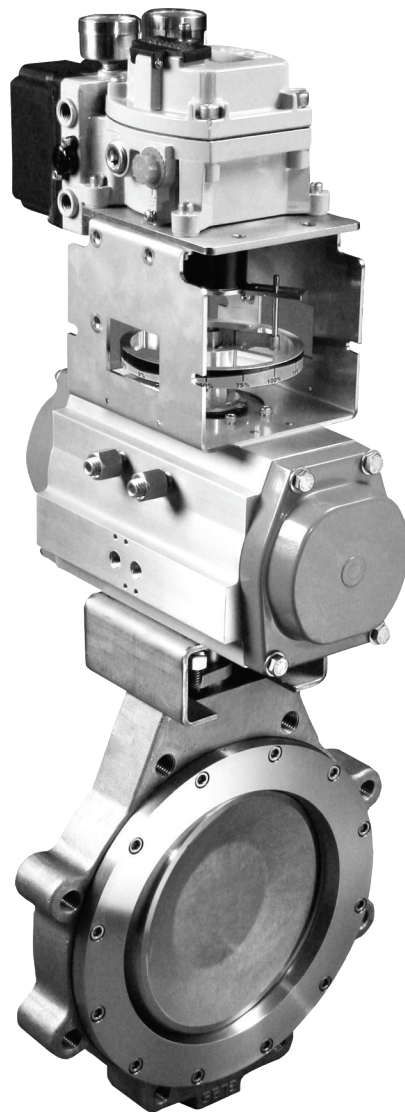

THESE INSTRUCTIONS PROVIDE THE CUSTOMER/OPERATOR WITH IMPORTANT PROJECT-SPECIFIC REFERENCE INFORMATION IN ADDITION TO THE CUSTOMER/OPERATOR'S NORMAL OPERATION AND MAINTENANCE PROCEDURES. SINCE OPERATION AND MAINTENANCE PHILOSOPHIES VARY, BAKER HUGHES COMPANY (AND ITS SUBSIDIARIES AND AFFILIATES) DOES NOT ATTEMPT TO DICTATE SPECIFIC PROCEDURES, BUT TO PROVIDE BASIC LIMITATIONS AND REQUIREMENTS CREATED BY THE TYPE OF EQUIPMENT PROVIDED.

THESE INSTRUCTIONS ASSUME THAT OPERATORS ALREADY HAVE A GENERAL UNDERSTANDING OF THE REQUIREMENTS FOR SAFE OPERATION OF MECHANICAL AND ELECTRICAL EQUIPMENT IN POTENTIALLY HAZARDOUS ENVIRONMENTS. THEREFORE, THESE INSTRUCTIONS SHOULD BE INTERPRETED AND APPLIED IN CONJUNCTION WITH THE SAFETY RULES AND REGULATIONS APPLICABLE AT THE SITE AND THE PARTICULAR REQUIREMENTS FOR OPERATION OF OTHER EQUIPMENT AT THE SITE.

THESE INSTRUCTIONS DO NOT PURPORT TO COVER ALL DETAILS OR VARIATIONS IN EQUIPMENT NOR TO PROVIDE FOR EVERY POSSIBLE CONTINGENCY TO BE MET IN CONNECTION WITH INSTALLATION, OPERATION OR MAINTENANCE. SHOULD FURTHER INFORMATION BE DESIRED OR SHOULD PARTICULAR PROBLEMS ARISE WHICH ARE NOT COVERED SUFFICIENTLY FOR THE CUSTOMER/OPERATOR'S PURPOSES THE MATTER SHOULD BE REFERRED TO BAKER HUGHES.

THE RIGHTS, OBLIGATIONS AND LIABILITIES OF BAKER HUGHES AND THE CUSTOMER/OPERATOR ARE STRICTLY LIMITED TO THOSE EXPRESSLY PROVIDED IN THE CONTRACT RELATING TO THE SUPPLY OF THE EQUIPMENT. NO ADDITIONAL REPRESENTATIONS OR WARRANTIES BY BAKER HUGHES REGARDING THE EQUIPMENT OR ITS USE ARE GIVEN OR IMPLIED BY THE ISSUE OF THESE INSTRUCTIONS.

THESE INSTRUCTIONS ARE FURNISHED TO THE CUSTOMER/OPERATOR SOLELY TO ASSIST IN THE INSTALLATION, TESTING, OPERATION, AND/OR MAINTENANCE OF THE EQUIPMENT DESCRIBED. THIS DOCUMENT SHALL NOT BE REPRODUCED IN WHOLE OR IN PART WITHOUT THE WRITTEN APPROVAL OF BAKER HUGHES.

Table Of Contents

| | |
|---|----------|
| Important: Safety Information | 1 |
| Introduction..... | 2 |
| 1.0 Installation..... | 2 |
| 2.0 Maintenance..... | 3 |
| 3.0 Stem Seal Replacement..... | 3 |
| 4.0 Seat Replacement..... | 3 |
| 5.0 Disc and Stem Replacement | 4 |
| | |
| Special Instructions for Fire Safe Butterfly Valve | 6 |
| 1.0 Installation..... | 6 |
| 2.0 Stem Seal Replacement..... | 6 |
| 3.0 Seat Replacement..... | 6 |
| 4.0 Stem and Disc Replacement | 6 |
| 5.0 Field Adjustments – All Valves..... | 6 |

Safety Information

Important – Please read before installation

These instructions contain **DANGER**, **WARNING**, and **CAUTION** labels, where necessary, to alert you to safety related or other important information. Read the instructions carefully before installing and maintaining your control valve. **DANGER** and **WARNING** hazards are related to personal injury. **CAUTION** hazards involve equipment or property damage. Operation of damaged equipment can, under certain operational conditions, result in degraded process system performance that can lead to injury or death. Total compliance with all **DANGER**, **WARNING**, and **CAUTION** notices is required for safe operation.



This is the safety alert symbol. It alerts you to potential personal injury hazards. Obey all safety messages that follow this symbol to avoid possible injury or death.



Indicates a potentially hazardous situation which, if not avoided, could result in death or serious injury.



Indicates a potentially hazardous situation which, if not avoided, could result in serious injury.



Indicates a potentially hazardous situation which, if not avoided, could result in minor or moderate injury.



When used without the safety alert symbol indicates a potentially hazardous situation which, if not avoided, could result in property damage.

Note: Indicates important facts and conditions.

About this Manual

- The information in this manual is subject to change without prior notice.
- The information contained in this manual, in whole or part, shall not be transcribed or copied without Baker Hughes's written permission.
- Please report any errors or questions about the information in this manual to your local supplier.
- These instructions are written specifically for the 39004 Series control valve, and do not apply for other valves outside of this product line.

Useful Life Period

The current estimated useful life period for the 39004 Series control valve is 25+ years. To maximize the useful life of the product, it is essential to conduct annual inspections, routine maintenance and ensure proper installation to avoid any unintended stresses on the product. The specific operating conditions will also impact the useful life of the product. Consult the factory for guidance on specific applications if required prior to installation.

Warranty

Items sold by Baker Hughes are warranted to be free from defects in materials and workmanship for a period of one year from the date of shipment provided said items are used according to Baker Hughes recommended usages. Baker Hughes reserves the right to discontinue manufacture of any product or change product materials, design or specifications without notice.

Note: Prior to installation

- The valve must be installed, put into service and maintained by qualified and competent professionals who have undergone suitable training.
- All surrounding pipe lines must be thoroughly flushed to ensure all entrained debris has been removed from the system.
- Under certain operating conditions, the use of damaged equipment could cause a degradation of the performance of the system which may lead to personal injury or death.
- Changes to specifications, structure, and components used may not lead to the revision of this manual unless such changes affect the function and performance of the product.

Introduction

The Masoneilan 39004 Series High Performance Butterfly Valve (HPBV) is a double-offset design, suitable for a wide range of services, including oxygen, chlorine, sour gas, vacuum, and steam applications. Bubbletight shutoff is provided throughout a wide range of operating conditions.

Suitable for both modulating and on/off services, the 39004 butterfly valve is easily automated with your choice of manual operators, electric and pneumatic actuators, positioners, and controls.

The 39004 HPBV is available in a Fire Safe model qualified to API 607 4th Edition and BS 6755 part 2.

Additional information about the Masoneilan 39004 HBPV – including application data, engineering specifications, and actuator selection is available from the GEA20232 Technical Specifications as well as your Baker Hughes sales representative.

1. Installation

Special instructions for Fire Safe valves appear on page 6.

1. The 39004 Series High Performance Butterfly Valve is designed to be mounted between ASME flanges. When the valve is open, the disc will extend into the pipe on both sides of the valve – further on the body side than the seat retainer side of the valve. Piping must be large enough to allow the disc to clear the pipe. The charts below show the minimum pipe ID allowable, and standard pipe IDs. In

general, Class 150 valves will clear Schedule 40 pipe, and Class 300 valves will clear Schedule 80 pipe adequately. Class 600 will in general clear Schedule 80 sizes 3, 4, and 6; and Schedule 100 in sizes 8, 10, 12, 14, and 16.

2. If handle or actuator has been removed, do not rotate disc beyond full open or closed position – this could cause damage to sealing surfaces. (NOTE: The 39004 Series valves are equipped with stops to prevent over closure.) The valve is opened by turning counter-clockwise, closed by turning clockwise. The double “D” flats or keyway at the top of the stem is parallel to the disc edge.
3. For maximum service life, install the valve with the seat retainer upstream. Positive shutoff will be obtained with the valve in either position; however, installation with the seat retainer upstream will give longer service life, especially in erosive services.
4. With the disc in closed position, carefully center valve between flanges. Guide holes (wafer pattern valve) or tapped holes (lugged valves) match ASME pipe flanges and assist in positive alignment.
5. Use standard torques when bolting valve into the line. The seat is sufficiently compressed by the seat retainer, and additional force from flange bolting is not required.
6. Gaskets should conform to the requirements of API Standard 601, Edition 3 for ASME/ANSI B16.5 class flanges. Spiral wound gaskets, such as Flexitallic CG or CGI series, conforming to ASME/ANSI B16.20 are acceptable.

Minimum Inside Diameter of Pipe with the Recommended Clearance

| Valve Size | Class | | |
|------------|-------|-------|-------|
| | 150 | 300 | 600 |
| 3 | 2.86 | 2.86 | 2.75 |
| 4 | 3.72 | 3.72 | 3.56 |
| 6 | 5.88 | 5.75 | 5.38 |
| 8 | 7.80 | 7.56 | 6.88 |
| 10 | 9.78 | 9.44 | 8.50 |
| 12 | 11.74 | 11.31 | 10.12 |
| 14 | 12.90 | 11.38 | 10.88 |
| 16 | 14.68 | 14.31 | 12.62 |
| 18 | | | 14.40 |
| 20 | | | 15.86 |
| 24 | 22.50 | 20.68 | |
| 30 | 28.55 | 27.06 | |
| 32 | 30.69 | | |
| 36 | 34.50 | 33.63 | |
| 40 | 37.55 | 36.59 | |
| 42 | 39.55 | 38.67 | |
| 44 | | 38.67 | |
| 48 | 51.09 | 45.13 | |
| 54 | 52.95 | | |
| 60 | 58.25 | | |

Nominal Inside Diameter of Pipe

| Valve Size | Schedule | | |
|------------|----------|--------|--------|
| | 40 | 80 | 100 |
| 3 | 3.068 | 2.900 | |
| 4 | 4.026 | 3.826 | |
| 6 | 6.065 | 5.761 | |
| 8 | 7.981 | 7.625 | 7.439 |
| 10 | 10.020 | 9.564 | 9.314 |
| 12 | 11.938 | 11.376 | 11.064 |
| 14 | 13.124 | 12.500 | 12.126 |
| 16 | 15.000 | 14.314 | 13.938 |
| 18 | 16.876 | 16.126 | |
| 20 | 18.814 | 17.938 | |
| 24 | 22.626 | 21.564 | |

NOTES:

1. Minimum I.D. of pipe with recommended clearances (per API 609) have been calculated by adding the minimum I.D. with zero clearance to a minimum recommended diametric clearance for each pipe size.
2. These charts assume that the pipe is on the body side of the valve and that the pipe is perfectly centered. The seat retainer side of the valve will always have more clearance than the body side.
3. A minimum of 1/16" thick gasket is used between the pipe flange and valve body face.
4. When using a pipe whose I.D. is smaller than the recommended minimum inside diameter of pipe with adequate clearance, a chamfer of 45° should be provided on the end of the pipe so that it clears the disc.

2. Maintenance

1. Reasonable precautions should be taken before beginning work on the valve. Protective clothing, as required by the specific line fluid, should be worn.
2. Before removing handle or the actuator from the valve, or before removing seat retainer from a valve in dead end service, close the valve and depressurize the line. The eccentric design of the 39004 Series may allow line pressure to open the valve if the handle / actuator is not in place while the valve is under pressure.

DO NOT PRESSURIZE THE LINE WITHOUT A HANDLE OR ACTUATOR ON THE VALVE.

3. The 39004 Series valve must be in the closed position to be removed from the line.
4. Begin all work on a valve that has been removed from the line by cleaning the valve, removing any grit or scale. When handling the valve, care should be taken not to scratch the disc edge or seats.
5. Replacement seats, seals and other parts are available from authorized distributors. Contact your distributor or sales representative for details of price and delivery.

3. Stem Seal Replacement

Refer to drawing on page 5 for parts identification.

1. If required, remove handle assembly. Remove socket head cap screws (21) and lock washers (22). Remove mounting bracket (20). For actuated valves, unbolt mounting bracket from body and lift actuator assembly off stem. Note assembly positions before removal.
2. Remove gland retainer nuts (14) and lock washers (13). Remove gland retainer (11) anti-blowout retaining ring or split ring (10) (depending on size), and gland ring (7).
3. Hook out stem seals (8), taking care not to scratch stem or stuffing box bore. Do not remove thrust washer (9), unless further valve disassembly is required.
4. Examine stuffing box bore and stem, clean as necessary to remove any corrosion or foreign matter before installing new seals.
5. Install new seals in stuffing box one at a time, TFE (white) seals first, with the carbon fiber ring at the top. Stagger seal ring joints 180° apart when installing. Tamp each ring to bottom before installing next ring.

Note: On the larger valves it will be necessary to compress each seal before adding the next.

6. Slide gland ring (7) over stem on top of seals (8). Install anti-blowout retaining ring or split ring (10) (depending on valve size). Slide gland retainer (11) over stem and onto gland studs (12). Place lockwashers (13) and hex nuts (14) on studs (12) and tighten finger tight. Tighten gland nuts (14) evenly and alternately to the proper torque value given in Table 2.
7. Remount actuator, or mounting bracket (20) with lock washers (22) and cap screws (21) and handle (27). Tighten handle set screw (28) to secure the handle to the valve stem.
8. Operate valve open and closed several times, to check for binding and to set the stem seals. Loosen gland nuts (14) and retighten to torque value given in Table 2.

Table 1 - Total Number of Stem Seals
CF = Carbon Fiber

| Valve Size | Class 150 | | Class 300 | | Class 600 | |
|------------|----------------------|-------------------|----------------------|-------------------|----------------------|-------------------|
| | Number of Stem Seals | Material CF / TFE | Number of Stem Seals | Material CF / TFE | Number of Stem Seals | Material CF / TFE |
| 3 | 4 | 1 / 3 | 4 | 1 / 3 | 12 | 2 / 10 |
| 4 | 4 | 1 / 3 | 4 | 1 / 3 | 12 | 2 / 10 |
| 6 | 4 | 1 / 3 | 4 | 1 / 3 | 16 | 2 / 14 |
| 8 | 5 | 1 / 4 | 5 | 1 / 4 | 16 | 2 / 14 |
| 10 | 5 | 1 / 4 | 5 | 1 / 4 | 18 | 0 / 18 |
| 12 | 5 | 1 / 4 | 5 | 1 / 4 | 18 | 0 / 18 |
| 14 | 6 | 0 / 6 | 6 | 0 / 6 | 18 | 0 / 18 |
| 16 | 6 | 0 / 6 | 9 | 0 / 9 | 16 | 0 / 16 |
| 18 | | | | | 16 | 0 / 16 |
| 20 | | | | | 16 | 0 / 16 |
| 24 | 10 | 0 / 10 | 8 | 0 / 8 | | |
| 30 | 8 | 0 / 8 | 9 | 0 / 9 | | |
| 32 | 8 | 0 / 8 | | | | |
| 36 | 8 | 0 / 8 | 9 | 0 / 9 | | |
| 40 | 9 | 0 / 9 | 9 | 0 / 9 | | |
| 42 | 9 | 0 / 9 | 9 | 0 / 9 | | |
| 44 | | | 9 | 0 / 9 | | |
| 48 | 9 | 0 / 9 | 9 | 0 / 9 | | |
| 54 | 9 | 0 / 9 | | | | |
| 60 | 9 | 0 / 9 | | | | |

4. Seat Replacement

1. With the disc in the closed position, remove the valve from the line.
2. Lay the valve down with the disc in the closed position and the seat retainer side facing up.
3. Remove the socket head cap screws (17), the seat retainer (16), and seat (15).
4. Carefully clean the seat area in the body and seat retainer. Remove foreign matter, dirt, etc. Check disc seating area for nicks or scratches.
5. Place the new seat (15) on disc (2), carefully centering it in the recess in the body.
6. Align the holes in the seat retainer (16) with matching holes in body and carefully place in position on top of seat (15). Be careful not to shift retainer to align holes so that seat is not shifted from correct position. Lightly grease cap screw (17) threads and tighten down evenly, alternating from top to bottom and side-to-side. Tighten to the torque value in Table 2.
7. Operate valve several times and examine seat for any damage before reinstalling the valve in the line.

Table 2 - Gland Retainer Nut and Seat Retainer Screw Torque

| Valve Size | Gland Nut | | | Seat Retainer Screws | | |
|------------|-----------|-----|-----|----------------------|------|------|
| | 150 | 300 | 600 | 150 | 300 | 600 |
| 3 | 60 | 60 | 80 | 100 | 100 | 100 |
| 4 | 60 | 60 | 100 | 175 | 175 | 175 |
| 6 | 80 | 120 | 140 | 100 | 175 | 300 |
| 8 | 80 | 140 | 200 | 175 | 175 | 300 |
| 10 | 110 | 190 | 200 | 175 | 300 | 300 |
| 12 | 130 | 220 | 200 | 300 | 300 | 300 |
| 14 | 130 | 200 | 240 | 300 | 300 | 500 |
| 16 | 150 | 220 | 240 | 300 | 300 | 750 |
| 18 | | | 400 | | | 1500 |
| 20 | | | 480 | | | 1500 |
| 24 | 190 | 240 | | 500 | 500 | |
| 30 | 210 | 310 | | 500 | 750 | |
| 32 | 210 | | | 750 | | |
| 36 | 240 | 360 | | 500 | 1500 | |
| 40 | 280 | 420 | | 500 | 1500 | |
| 42 | 280 | 420 | | 500 | 1500 | |
| 44 | | 420 | | | 1500 | |
| 48 | 300 | 600 | | 750 | 1500 | |
| 54 | 360 | | | | 1500 | |
| 60 | 500 | | | | 1500 | |

5. Disc and Stem Replacement

Refer to drawing on page 5 for parts identification.

Note: Stem and disc are supplied as a matched set with taper pins and are to be replaced as a set.

- For handle-operated valves, loosen set screw (28) and remove handle assembly (27). Remove socket head cap screws (21) and lock washers (22). Remove mounting bracket (20). For actuated valves, unbolt mounting bracket from body and lift actuator assembly off stem. Note assembly positions before removal.
- Remove gland retainer nuts (14) and lock washers (13). Remove gland retainer (11), anti-blowout retaining ring or split ring (10) (depending on valve size), and gland ring (7).
- Hook out stem seals (8) taking care not to scratch stem or stuffing box bore.
- Remove locating plug (19) and gasket (18).
- Remove cap screws (17), seat retainer (16), and seat (15).
- Turn disc to the full open position and drill out tack welds on large end of taper pins (4). Take care to support valve so that disc surfaces are not scratched. Drill sizes to remove tack welds as given in Table 3.
- Place valve in flat position, with flat face of disc up. Support disc and body on wooden blocks to protect disc and body surfaces. Disc will rest in partially open position.
- Knock out taper pins (4) using a rod or punch on small end of pin (opposite tack weld). It may be necessary to lift body and rotate disc slightly to do this. Make sure disc is resting on wood block since it will swing freely on stem with pins removed. When pins (4) are out, lay body down so disc and body are evenly supported on flat surface.
- Using a brass bar or drift punch, knock stem (3) loose and pull from body. After long or severe service this may take considerable force. Be careful not to damage bearings, spacers or body.
NOTE: Disc spacers (5) are used at top and bottom of disc to properly position disc in body. Proper spacers were selected at initial assembly and rarely require replacement. The location of these spacers should be noted, and the spacers marked at disassembly so that they are reinstalled in the same positions, top and bottom.
- Separate body from disc, and remove thrust washer (9) from packing bore.
- Examine stem bearings (6) for excessive wear. If removed from body, note position and mark to reinstall in same location. Replacement is rarely needed, however, if bearing liner is worn through to the shell, or severe damage is evident they should be replaced.
- Clean body thoroughly to remove all dirt, foreign matter, rust, etc.
- Place the body (1) flat, seat retainer side up, and support it on wooden blocks sufficiently above the work surface as to facilitate insertion of the disc (2) in open position. Lower the disc into position, aligning the bores in body and disc.
- Insert new stem (3) in body (1) with large end of the taper pin holes toward the top. Assemble disc spacers (5) as stem (3) is inserted, making sure that spacers are returned to original locations as marked.
- Align taper pin holes in disc and stem, and install taper pins (4). Drive pins in tightly with rod or punch, and tack weld each pin (4) to disc (2) at large end of pin.
- Install new gasket (18) on locating plug (19) and install plug in body.
- Install new stem seals, following instructions in "Stem Seal Replacement" section.
- Install new seat, following instructions in "Seat Replacement" section.
- Remount handle assembly or actuator, and operate valve several times to verify proper operation. Examine disc and seat for any damage before reinstalling in line.

Table 3 - Drill Size to Remove Tack Weld (in.)

| Valve Size | Class | | | | | |
|------------|-------|---------|-------|---------|-------|--------|
| | 150 | | 300 | | 600 | |
| 3 | .234 | 15/64 | .234 | 15/64 | .250 | 1/4 |
| 4 | .234 | 15/64 | .234 | 15/64 | .289 | 9/32 |
| 6 | .234 | 15/64 | .234 | 15/64 | .341 | 1-1/32 |
| 8 | .234 | 15/64 | .234 | 15/64 | .591 | 19/32 |
| 10 | .234 | 15/64 | .234 | 15/64 | .706 | 45/64 |
| 12 | .234 | 15/64 | .234 | 15/64 | .706 | 45/64 |
| 14 | .591 | 19/32 | .234 | 15/64 | .706 | 45/64 |
| 16 | .706 | 45/64 | .706 | 45/64 | 1.032 | 1-1/32 |
| 18 | | | | | 1.032 | 1-1/32 |
| 20 | | | | | 1.241 | 1-1/4 |
| 24 | .706 | 45/64 | 1.032 | 1-1/32 | | |
| 30 | 1.033 | 1-1/32 | 1.241 | 1-1/4 | | |
| 32 | 1.033 | 1-1/32 | | | | |
| 36 | 1.033 | 1-1/32 | 1.241 | 1-1/4 | | |
| 40 | 1.241 | 1-1/4 | 1.521 | 1-17/32 | | |
| 42 | 1.241 | 1-1/4 | 1.521 | 1-17/32 | | |
| 44 | | | 1.521 | 1-17/32 | | |
| 48 | 1.241 | 1-1/4 | 1.521 | 1-17/32 | | |
| 54 | 1.521 | 1-17/32 | | | | |
| 60 | 1.521 | 1-17/32 | | | | |

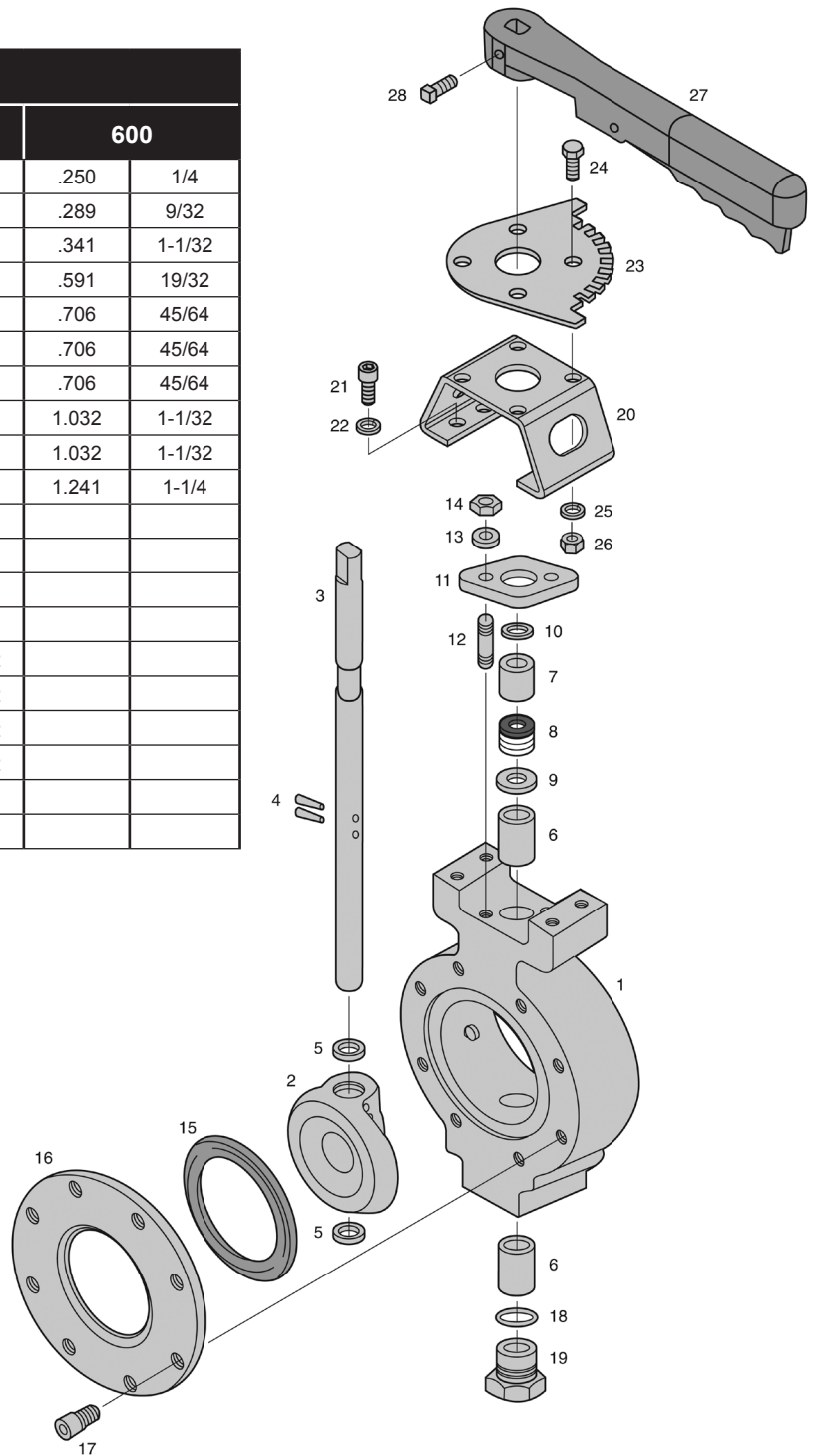

Parts List

| Ref No. | Description |
|---------|------------------|
| 1. | Body |
| 2. | Disc |
| 3. | Stem |
| 4. | Taper Pin |
| 5. | Disc Spacer |
| 6. | Bearing Assembly |
| 7. | Gland Ring |
| 8. | Stem Seal |
| 9. | Thrust Washer |
| 10. | Retaining Ring |

| Ref No. | Description |
|---------|---------------------|
| 11. | Gland Retainer |
| 12. | Stud |
| 13. | Lock Washer |
| 14. | Hex Nut |
| 15. | Seat Assembly |
| 16. | Seat Retainer Plate |
| 17. | Cap Screw |
| 18. | O-Ring Gasket |
| 19. | Locating Plug |

| Ref No. | Description |
|---------|------------------|
| 20. | Mounting Bracket |
| 21. | Cap Screw |
| 22. | Lock Washer |
| 23. | Notch Plate |
| 24. | Bolt |
| 25. | Lock Washer |
| 26. | Hex Nut |
| 27. | Handle Assembly |
| 28. | Handle Set Screw |

Special Instructions For Fire Safe Butterfly Valve

1. Installation

1. The Fire Safe 39004 Series valve will provide fire-safe shutoff with flow in either direction, meeting API 607 and British Standard 6755 part 2 criteria, as well as bubble-tight shutoff in either direction in normal service. However, installation with the seat retainer upstream provides maximum protection to the soft seat, and will increase seat life, especially in erosive services.
2. Installation bolting information and dimensional data given for the standard Masoneilan valves is also applicable to the Fire Safe versions.

2. Stem Seal Replacement

The procedure for replacement on page 3 also applies to Fire Safe valves, with the following exceptions:

1. Graphite stem seals are used in the Fire Safe valves. The arrangement of the two types of stem seals when installed is: bottom seal carbon fiber braided ring; center seals – graphite rings; top seal carbon fiber braided ring.
2. Table 4 shows stem seal quantities for class 150 and 300 valves.

Table 4 - Total Number of Stem Seals

CF = Carbon Fiber

G = Formed Graphite

| Valve Size | Class 150 | | Class 300 | | Class 600 | Gland Nut Torque | |
|------------|----------------------|-----------------|----------------------|-----------------|----------------------|------------------|-----------|
| | Number of Stem Seals | Material CF / G | Number of Stem Seals | Material CF / G | | Class 150 | Class 300 |
| 3 | 4 | 2 / 2 | 4 | 2 / 2 | NO FIRE SAFE VERSION | 35 | 45 |
| 4 | 4 | 2 / 2 | 4 | 2 / 2 | | 35 | 45 |
| 6 | 4 | 2 / 2 | 4 | 2 / 2 | | 45 | 65 |
| 8 | 5 | 2 / 3 | 5 | 2 / 3 | | 45 | 80 |
| 10 | 5 | 2 / 3 | 5 | 2 / 3 | | 65 | 100 |
| 12 | 5 | 2 / 3 | 5 | 2 / 3 | | 65 | 100 |
| 14 | 6 | 2 / 4 | 8 | 2 / 6 | | 80 | 125 |
| 16 | 6 | 2 / 4 | 9 | 2 / 7 | | 100 | 150 |
| 18 | 9 | 2 / 7 | 9 | 2 / 7 | | 100 | 150 |
| 20 | 9 | 2 / 7 | 9 | 2 / 7 | | 100 | 150 |
| 24 | 10 | 2 / 8 | 8 | 2 / 6 | | 150 | 200 |

3. Seat Replacement

1. With the disc in the closed position, remove the valve from the line.
2. Lay the valve down with the disc in the closed position and the seat retainer side facing up.
3. Remove socket head cap screws, seat retainer, metal fire seat, gaskets, and soft seat.
4. Carefully remove graphite gaskets from metal seat. Do not bend or crimp metal seat. All traces of the old gaskets must be removed.
5. Clean seat retainer and body surfaces to remove any adhering gasket material, corrosion, or other foreign material. Examine disc seating surfaces for damage, and

examine seating surface of metal seat for wear or damage. Replace if damaged.

6. Place new seat on disc, carefully centering in body recess.
7. Place new graphite gasket on the body. Position metal seat over the disc, lip facing out, on top of the polymer seat. Place another graphite gasket on top of the metal seat. Graphite gaskets can be first attached to the metal seat to simplify the assembly. Spray a suitable adhesive, like 3M Super 77™ general purpose adhesive or similar, in 3 or 4 spots on both sides of the metal seat to hold the gaskets in position. Handle the gaskets carefully as they are very thin and are easily torn or scratched.
8. Align holes in seat retainer with holes in body and seat, and carefully place seat retainer in position, on top of seat. Be careful that seats do not shift when retainer is installed. Lightly grease cap screw threads and tighten down evenly in a criss-cross pattern to assure proper centering and uniform compression. Torque cap screws to the values given in Table 2 on page 4.
9. Lubricate the disc edge with molybdenum disulfide spray or similar lubricant, if available. As a minimum, lubricate the disc edge with light machine oil or light grease. Operate valve several times and examine seat for damage before reinstalling in line.

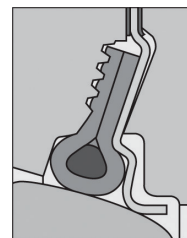

4. Stem and Disc Replacement

The same procedures apply to Fire Safe valves as to the standard valves, with the addition of the special requirements for stem seal and seat replacement.

5. Field Adjustments – All Valves

Stem Seal Leakage

Should leakage occur at the stem seals, it may be stopped by retightening the gland retainer nuts to the values specified in Tables 2 or 4. Do not overtighten gland nuts, as this may cause increased operating torque, and improper valve operation or closure. If the leakage cannot be stopped by this action, the stem seals require replacement.

Adjusting Valve Closure

Valves with gear actuators or electric / pneumatic actuators may require adjustment of the travel stops in the actuator to properly close valve for tight shut-off. The following procedure should be followed to set travel or limit stops. (It is recommended that the valve must be removed from line for this procedure and actuator mounting).

1. Using a straight-edge and vernier or depth caliper, measure the distances from the face of the seat retainer to the disc (valve closed) face at the 3 o'clock and 9 o'clock positions (stem is at 12 o'clock position). The measurements must agree within 1/16" (0.062").

2. If they do not agree, disc must be rotated in the direction of the larger dimension. If the 3 o'clock dimension is larger, the disc is not fully closed, and must be rotated in the "close" direction more. If 9 o'clock dimension is larger, disc is over-closed, and must be opened slightly.
3. The valve disc is at the full open position when the disc is perpendicular to the body. Set the "open" actuator stop for this position. Do not allow the valve to over-open as this may damage the disc seating surfaces by hitting body or attached piping.
4. On gear operators, loosen and adjust the closing stop screw to permit proper disc positioning. Adjust and lock down when disc closure is within measured tolerance in paragraph 1. Open and close valve; recheck measurements before reinstalling in line.
5. For other power actuators, consult the manufacturer's instructions for setting travel stops, as these vary with actuator model and type.
6. If removing the valve from the line is not practical, as a crude remedy the disc can be placed into a position in the seat at which the leakage stops and travel stops are adjusted to this position.

Notes

Direct Sales Office Locations

Australia

Brisbane
Phone: +61-7-3001-4319

Perth
Phone: +61-8-6595-7018

Melbourne
Phone: +61-3-8807-6002

Brazil

Phone: +55-19-2104-6900

China

Phone: +86-10-5738-8888

France

Courbevoie
Phone: +33-1-4904-9000

India

Mumbai
Phone: +91-22-8354790

New Delhi

Phone: +91-11-2-6164175

Italy

Phone: +39-081-7892-111

Japan

Tokyo
Phone: +81-03-6871-9008

Korea

Phone: +82-2-2274-0748

Malaysia

Phone: +60-3-2161-03228

Mexico

Phone: +52-55-3640-5060

Russia

Veliky Novgorod
Phone: +7-8162-55-7898

Moscow

Phone: +7-495-585-1276

Saudi Arabia

Phone: +966-3-341-0278

Singapore

Phone: +65-6861-6100

South Africa

Phone: +27-11-452-1550

**South & Central
America and the Caribbean**

Phone: +55-12-2134-1201

Spain

Phone: +34-935-877-605

United Arab Emirates

Phone: +971-4-8991-777

United Kingdom

Phone: +44-7919-382-156

United States

Houston, Texas
Phone: +1-713-966-3600

Find the nearest local Channel Partner in your area:

valves.bakerhughes.com/contact-us

Tech Field Support & Warranty:

Phone: +1-866-827-5378

valvesupport@bakerhughes.com

valves.bakerhughes.com

Copyright 2020 Baker Hughes Company. All rights reserved. Baker Hughes provides this information on an "as is" basis for general information purposes. Baker Hughes does not make any representation as to the accuracy or completeness of the information and makes no warranties of any kind, specific, implied or oral, to the fullest extent permissible by law, including those of merchantability and fitness for a particular purpose or use. Baker Hughes hereby disclaims any and all liability for any direct, indirect, consequential or special damages, claims for lost profits, or third party claims arising from the use of the information, whether a claim is asserted in contract, tort, or otherwise. Baker Hughes reserves the right to make changes in specifications and features shown herein, or discontinue the product described at any time without notice or obligation. Contact your Baker Hughes representative for the most current information. The Baker Hughes logo, Maseonilan are trademarks of Baker Hughes Company. Other company names and product names used in this document are the registered trademarks or trademarks of their respective owners.

Baker Hughes 