

51/52/53 Series

Cylinder Actuator

Instruction Manual (Rev. E)



THESE INSTRUCTIONS PROVIDE THE CUSTOMER/OPERATOR WITH IMPORTANT PROJECT-SPECIFIC REFERENCE INFORMATION IN ADDITION TO THE CUSTOMER/OPERATOR'S NORMAL OPERATION AND MAINTENANCE PROCEDURES. SINCE OPERATION AND MAINTENANCE PHILOSOPHIES VARY, BAKER HUGHES COMPANY (AND ITS SUBSIDIARIES AND AFFILIATES) DOES NOT ATTEMPT TO DICTATE SPECIFIC PROCEDURES, BUT TO PROVIDE BASIC LIMITATIONS AND REQUIREMENTS CREATED BY THE TYPE OF EQUIPMENT PROVIDED.

THESE INSTRUCTIONS ASSUME THAT OPERATORS ALREADY HAVE A GENERAL UNDERSTANDING OF THE REQUIREMENTS FOR SAFE OPERATION OF MECHANICAL AND ELECTRICAL EQUIPMENT IN POTENTIALLY HAZARDOUS ENVIRONMENTS. THEREFORE, THESE INSTRUCTIONS SHOULD BE INTERPRETED AND APPLIED IN CONJUNCTION WITH THE SAFETY RULES AND REGULATIONS APPLICABLE AT THE SITE AND THE PARTICULAR REQUIREMENTS FOR OPERATION OF OTHER EQUIPMENT AT THE SITE.

THESE INSTRUCTIONS DO NOT PURPORT TO COVER ALL DETAILS OR VARIATIONS IN EQUIPMENT NOR TO PROVIDE FOR EVERY POSSIBLE CONTINGENCY TO BE MET IN CONNECTION WITH INSTALLATION, OPERATION OR MAINTENANCE. SHOULD FURTHER INFORMATION BE DESIRED OR SHOULD PARTICULAR PROBLEMS ARISE WHICH ARE NOT COVERED SUFFICIENTLY FOR THE CUSTOMER/OPERATOR'S PURPOSES THE MATTER SHOULD BE REFERRED TO BAKER HUGHES.

THE RIGHTS, OBLIGATIONS AND LIABILITIES OF BAKER HUGHES AND THE CUSTOMER/OPERATOR ARE STRICTLY LIMITED TO THOSE EXPRESSLY PROVIDED IN THE CONTRACT RELATING TO THE SUPPLY OF THE EQUIPMENT. NO ADDITIONAL REPRESENTATIONS OR WARRANTIES BY BAKER HUGHES REGARDING THE EQUIPMENT OR ITS USE ARE GIVEN OR IMPLIED BY THE ISSUE OF THESE INSTRUCTIONS.

THESE INSTRUCTIONS ARE FURNISHED TO THE CUSTOMER/OPERATOR SOLELY TO ASSIST IN THE INSTALLATION, TESTING, OPERATION, AND/OR MAINTENANCE OF THE EQUIPMENT DESCRIBED. THIS DOCUMENT SHALL NOT BE REPRODUCED IN WHOLE OR IN PART WITHOUT THE WRITTEN APPROVAL OF BAKER HUGHES.

Table Of Contents

Safety Information	4
Safety Symbols.....	4
51/52/53 Series Cylinder Actuator Product Safety	5
Pressure Equipment Directive - (DIRECTIVE 2014/68/EU).....	7
Introduction	8
General.....	8
Actuator Description	8
Installation	8
Unpacking.....	8
Pneumatic Supply Connections.....	8
Mounting.....	9
Operation	11
Actuator	11
Handwheel Manual Override (Optional)	11
Switching from Auto Operation to Manual Operation Mode	14
Switching from Manual Operation to Auto Operation Mode.....	15
Hydraulic Manual Override (Optional)	16
Filling the Reservoir for Single Acting and Double Acting Units.....	17
Maintenance	18
Actuator Removal	18
Double Acting (Model 51) With or Without Handwheel, With/Without Volume Chamber.....	19
Air-to-Extend (Model 52) With or Without Handwheel	21
Air-to-Retract (Model 53) With or Without Handwheel.....	23
Maintenance Procedures.....	26
Model 51 O-ring, Guide Ring Replacement - Double Acting With or Without Handwheel	26
Model 52 O-ring, Guide Ring Replacement - Air-to-Extend with Handwheel	28
Model 52 O-ring, guide ring and Rod Scraper Replacement - Air-to-Extend Without Handwheel	30
Model 53 O-ring and Guide Ring Replacement - Air-to-Retract with Handwheel	33
Model 53 O-ring, guide ring and Rod Scraper Replacement - Air-to-Retract Without Handwheel.....	35
Spring Cartridge Removal	37

Safety Information

Important - Please read before installation

These instructions contain **WARNING**, and **CAUTION** labels, where necessary, to alert you to safety related or other important information. Read the instructions carefully **before** installing and maintaining your equipment.

WARNING hazards are related to personal injury.

CAUTION hazards involve equipment or property damage. Operation of **damaged equipment can, under certain operational conditions, result in degraded process system performance that can lead to injury or death. Total compliance with all WARNING, and CAUTION notices is required for safe operation.**



Indicates a potentially hazardous situation which, if not avoided, could result in serious injury.



Moving parts can crush or cut. Keep hands clear.



Indicates a potentially hazardous situation, which if not avoided could result in property or data damage.



Indicates important facts and conditions

About this Manual

- The information in this manual is subject to change without prior notice.
- The information contained in this manual, in whole or part, shall not be transcribed or copied without Baker Hughes's written permission.
- Please report any errors or questions about the information in this manual to your local supplier.
- These instructions are written specifically for the 51/52/53 Series actuator, and do not apply for other actuator outside of this product line.

Useful Life

The current estimated useful life period for the 51/52/53 Series actuator is 25+ years. To maximize the useful life of the product, it is essential to conduct annual inspections, routine maintenance and ensure proper installation to avoid any unintended stresses on the product. The specific operating conditions will also impact the useful life of the product. Consult the factory for guidance on specific applications if required prior to installation.

Warranty

Items sold by Baker Hughes are warranted to be free from defects in materials and workmanship for a period of one year from the date of shipment provided said items are used according to Baker Hughes recommended usages. Baker Hughes reserves the right to discontinue manufacture of any product or change product materials, design or specifications without notice.

Note: Prior to installation

- The actuator must be installed, put into service and maintained by qualified and competent professionals who have undergone suitable training.
- All surrounding pipelines must be thoroughly flushed to ensure all entrained debris has been removed from the system.
- Under certain operating conditions, the use of damaged equipment could cause a degradation of the performance of the system which may lead to personal injury or death.
- Changes to specifications, structure, and components used may not lead to the revision of this manual, unless such changes affect the function and performance of the product.

51/52/53 Series Cylinder Actuator Product Safety

1. General installation, maintenance or replacement

- Products must be installed in compliance with all local and national codes and standards by qualified personnel using safe site work practices. Personal Protective Equipment (PPE) must be used per safe site work practices.
- Ensure proper use of fall protection when working at heights, per safe site work practices. Use appropriate safety equipment and practices to prevent the dropping of tools or equipment during installation.
- Personnel engaging in installation, commissioning and maintenance activities must be trained in proper safe site work practices and procedures when working with or around Baker Hughes supplied equipment.
- Verify that the air supply pressure does not exceed the marking on the information plate.

2. Installations in potentially explosive atmosphere, including ATEX Directive 2014/34/EU.

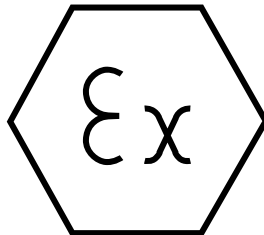

II 2 GD TX

- Install, put into service, use and maintain in compliance with national and local regulations and in accordance with the recommendations contained in the relevant standards concerning potentially explosive atmospheres.
- Use only in situations that comply with the certification conditions shown in this document and after verification of their compatibility with the zone of intended use.
- Install, put into service and maintain by qualified and competent professionals who have undergone suitable training for devices used in areas with potentially explosive atmospheres and have relevant certifications, as applicable.

WARNING

Before using these products with fluids/compressed gases other than air or for non-industrial applications, consult the factory.

Under certain operating conditions, the use of a damaged product could cause a degradation of the performance of the system, which can lead to personal injury or death.

Installation in poorly ventilated, confined areas, with any potential of gases other than oxygen being present, can lead to a risk of personnel asphyxiation.

- Only place in locations that are correctly identified. Refer to the device label for the description of the environment in which the device may be installed. Verify that the markings on the label are consistent with the application.
- Repairs should only be performed by service personnel qualified to make repairs on the actuator. Use only genuine replacement parts which are provided by the manufacturer, including not only the major assemblies but also mounting screws and O- rings, to guarantee that the products comply with the essential safety requirements of the European Directives.

WARNING

Explosion Hazard - Substitution of components may impair suitability for use in a hazardous location.

- If gasses other than air are used for supply, it is the end user's responsibility to recognize and safely contain any leaks or vents to atmosphere.
- If the pneumatic system is powered by a combustible gas it is the end user's responsibility to consider if the installation should be treated as a hazardous classified area.

Risk of Ignition

WARNING

Electrostatic Discharge: use only a damp cloth when cleaning to avoid electrostatic discharge, do not use solvent.

All elements are metal and in contact, thus the same potential. Ensure all electrical apparatus has a proper ground connection. Ensure the complete assembly has a proper ground connection.

Hot Surface - Process Operating Conditions - Actuator Information Plate Marking TX.

WARNING

Actuator surface temperature can be dependent on the process operating conditions

Masoneilan 51/52/53 actuators can withstand ambient temperatures at least equal to the **MAXIMUM OPERATING TEMPERATURE** (as shown on actuator information plate).

Surface temperature of the installed actuator will not be greater than the maximum process temperature of the connected valve body or other process equipment.

- The user shall take necessary actions to ensure the maximum actuator surface temperature does not exceed the temperature class of the application.

Pressure Equipment Directive - (DIRECTIVE 2014/68/EU)



0062

Dresser Valve India PVT Limited
Coimbatore, Tamilnadu, India

Minimum operating temperature: $-50^{\circ}\text{C}^{(1)}$

Maximum operating temperature: $83^{\circ}\text{C}^{(1)}$

Table 1 - Maximum Pressure ⁽¹⁾

Actuator	Pressure	
Size	Bar	PSI
12	10.3	150
16		
20		
24	6.9	100
28		
32		
40	4.9	72.5
46		

Note: Refer to the Actuator Information Plate for the serial number and date of manufacture.

1. The pressure and temperature limits noted are required to maintain a PED approved actuator installation.

Introduction

The following instructions are designed to assist maintenance personnel in performing most of the maintenance required on the Model 51/52/53 cylinder actuator. Baker Hughes has highly skilled service engineers available for start-up, maintenance and repair of our actuators and component parts. In addition, a regularly scheduled training program is conducted to train customer service and instrumentation personnel in the operation, maintenance and application of our control valves, actuators and instruments. Arrangements for training services can be made through your Baker Hughes representative or sales office. When performing maintenance, use only Masoneilan replacement parts. Parts are available through your local Baker Hughes representative or sales office. When ordering parts, always include the model and serial number of the unit being repaired.

Table 2 - Numbering System

Actuator Type	
51	Double Acting (No springs)
52	Air-to-extend (Extend stem)
53	Air-to-retract (Retract stem)

General

These installation and maintenance instructions apply to the Masoneilan Model 51/52/53 cylinder actuator, regardless of the valve body on which it is used. Actuator part numbers and recommended spare parts required for maintenance are listed in Table 5 on page 13. The model number and action of the actuator is shown as part of the model number listed on the identification tag located on the actuator.

Actuator Description

The Model 51/52/53 is a pneumatic cylinder actuator available in double acting spring-less and spring-return configurations. The double acting version can be configured with a volume chamber directly attached to the cylinder to provide a failsafe operation in the event of supply pressure loss. The spring-return version includes a spring cartridge subassembly. The spring is pre-compressed within the cartridge subassembly prior to assembly into the cylinder. This subassembly also provides guiding support and is isolated from the pressurized pneumatic section. This design provides reliability and maintainability.

Installation

Unpacking

Care must be exercised when unpacking the equipment to prevent damage to the accessories and component parts. If any problems or difficulties arise, contact your Baker Hughes representative or sales office.

Pneumatic Supply Connections

The Model 51/52/53 actuator is designed to accept 3/4" NPT air supply connections. Accessories supplied with the actuator are mounted and connected at the factory.

CAUTION

Do not exceed supply pressure indicated on identification plate.

CAUTION

RETURNING TO SERVICE: After installation or maintenance, ensure the equipment has been properly inspected and returned to proper condition before returning to service.

! NOTE

Placement of the valve actuator assembly should consider ease of access in the event of assembly or disassembly.

! NOTE

For mounting horizontally, consult with the factory for technical advice.

Mounting

The following installation and plug stem adjustment procedures are for mounting of the 51/52/53 actuators on metal seated reciprocating valves. Refer to the specific valve instructions for other trim types, such as pilot operated valves and soft seat designs.

WARNING

During assembly or maintenance, and under operation in some conditions, the operators or technicians must be alert and aware of all possible pinch points or areas where there are moving or sliding components.

1. Install the actuator on to the valve body and tighten the mounting hardware to the proper torque.
2. Connect a controlled pressure source to the:
 - Yoke (bottom side) for model 51 double acting and model 53 Air-to-retract.
 - Top plate (top side) for model 52 Air-to-extend.
3. Retract the actuator stem either pneumatically or manually using a handwheel until contact has been made with the top plate and piston (full open position).
4. Extend the actuator stem until it reaches the valve rated stroke, either pneumatically or with a handwheel, and maintain the position.
5. Position the split clamp with the split clamp to bonnet (SB) gap as shown in Table 3 on page 10. If the split clamp does not properly engage with both stems, slightly extend the actuator stem until alignment and engagement is achieved ([Figure 1](#)).

Table 3 - Split Clamp Positioning

Size	SB Gap
12	125 mm (4.92")
16	109 mm (4.29")
20, 24, 28, 32, 40, 46	115 mm (4.53")

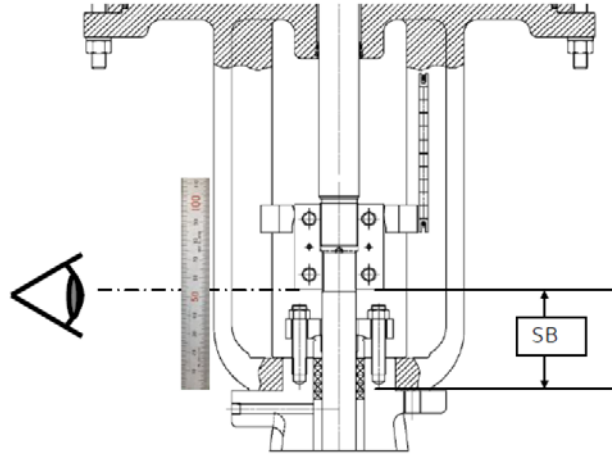

Figure 1 - Sighting the Split Clamp

- Install the mating side of split clamp and tighten the clamping screws carefully and evenly in a crisscross pattern to the torque recommended in Table 4.

Table 4 - Split Clamp Torque

Size	Dry	Lubricated
M12	88 N-m (65 ft-lbs)	66 N-m (49 ft-lbs)
M16	218 N-m (160 ft-lbs)	164 N-m (120 ft-lbs)
M20	438 N-m (323 ft-lbs)	329 N-m (242 ft-lbs)
M24	629 N-m (463 ft-lbs)	472 N-m (348 ft-lbs)

- Assemble and tighten the indicator arm, spring lock washers and hexagon bolts.
- Temporarily tighten the cross recessed head screw and fix the indicator plate.
- Mark the indicator arrow on to the indicator arm with a punch.
- Adjust the indicator plate to the correct position, as shown in [Figure 2](#).

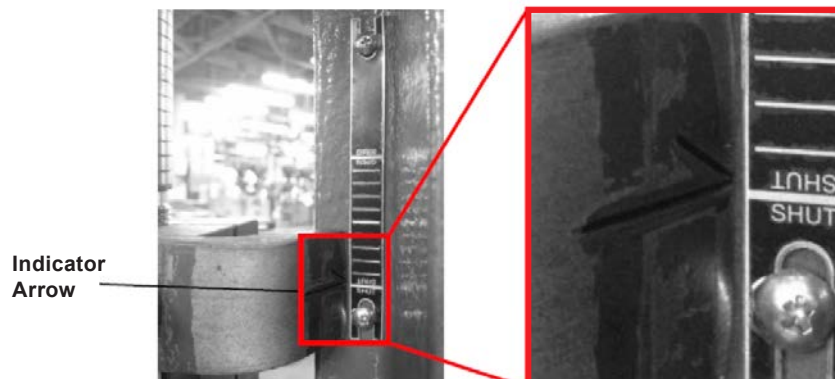

Figure 2 - Indicator Arrow

- Verify that the valve rated stroke is achieved, then remove the controlled pressure source.

Operation

Actuator

Increasing air pressure into the top plate moves the piston plate subassembly (15) down, while increasing pressure into the yoke moves the piston plate subassembly up towards the top plate. The spring-return versions provide mechanical fail-safe operation in the desired direction in case air supply pressure is lost.

CAUTION

Do not exceed supply pressure indicated on identification plate.

Handwheel Manual Override (Optional)

There are two handwheel designs (CM and DM) available, depending on actuator size. A handwheel provides manual control of the valve position in case of air supply failure. Operation of the CM and DM handwheels are the same.

CAUTION

For pneumatic operation, the handwheel must be placed in the auto position. Travel is locked if the handwheel is not in the auto position.

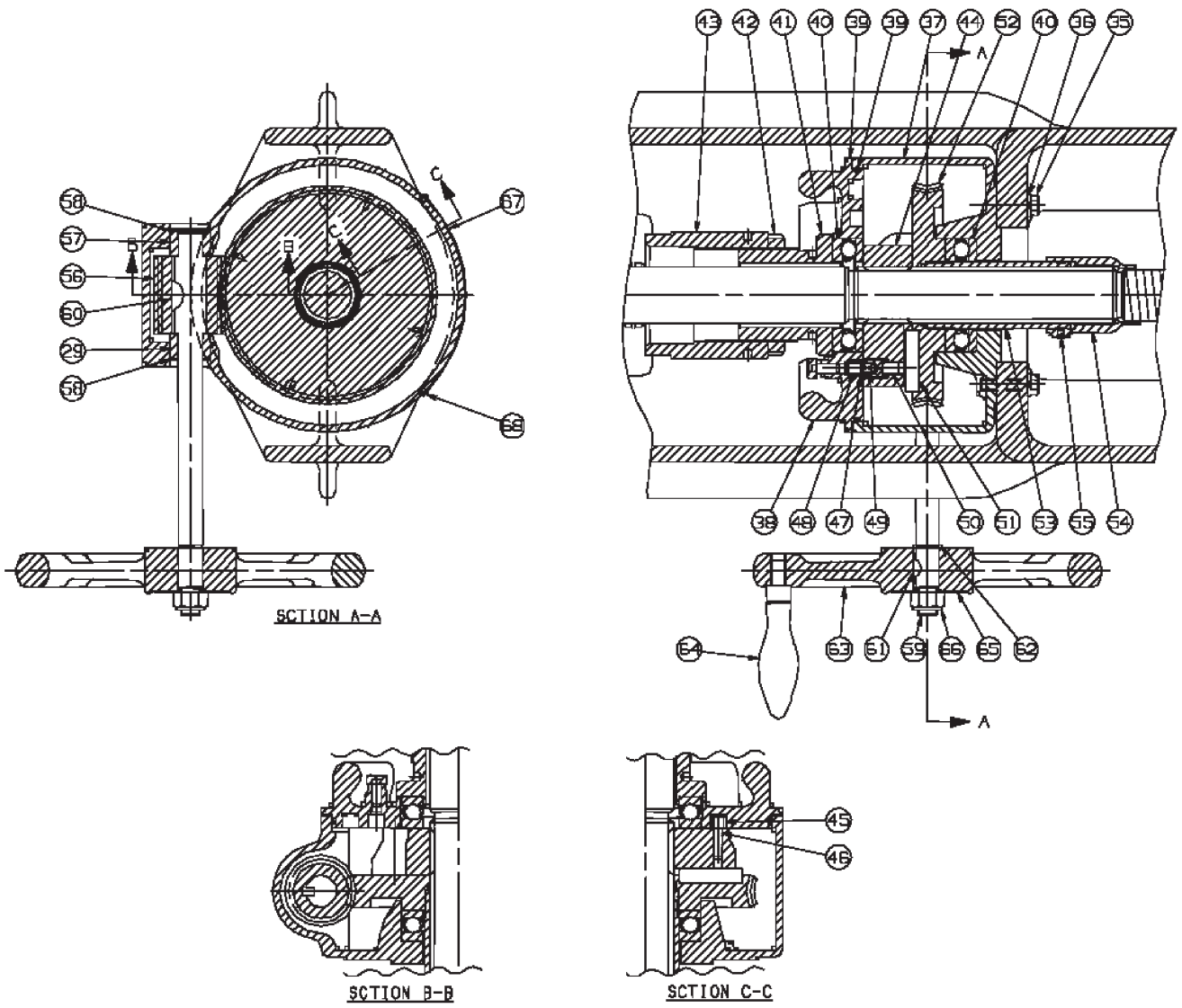

Figure 3 - CM, DM Handwheel

Table 5 - Parts References of 51/52/53 Actuators

Ref. #	Description	Ref. #	Description	Ref. #	Description
1	Yoke	24	Hexagon bolt	47	Locking pin case
2	Piston rod S/A	25	Spring lock washer	48	Pin
3	Lower spring button	26	Indicator plate	49	Spring
4	Spring	27	Cross recessed head screw	50	Hexagon socket set screw
5	Hexagon socket head cap screw	28	Exhaust pipe	51	Guide key
6	Spring lock washer	29	Spring lock washer	52	Worm gear
7	Spring tube	30	Plug	53	Spacer tube
8	Guide bushing	● 31	Piston S/A	54	Adapter
9	Compression bolt	● 32	Guide bushing	55	Set screw
10	Upper spring button	● 33	O-ring (Piston rod)	56	Worm
11	Thrust bearing	● 34	Rod scraper	● 57	Bearing
12	Compression nut	35	Hexagon bolt	58	Retaining ring
13	Separator plate/ Model 52/53	36	Spring lock washer	59	Handwheel shaft
14	Cylinder tube	37	Gearbox	60	Key (Worm)
15	Piston plate S/A	38	Gearbox cover S/A	61	Key (handwheel)
● 16	Guide ring	● 39	O-ring	62	Retaining ring
17	Top plate	● 40	Thrust bearing	63	Handwheel
18	Set screw	41	Adjustment screw	64	Grip
19	Center bolt	42	Locking nut	65	Directional plate
20	Hexagon nut	43	Adjustment nut	66	Self locking nut
● 21	O-ring (Piston, Top plate)	44	Piston rod engagement	67	Operating information plate
22	Split clamp	● 45	Bearing	68	Drive screw
23	Indicator arm	46	Retaining pin	69	Separator plate (Model 51)
				70	Volume chamber tube

● Recommended spare parts

Switching from Auto Operation to Manual Operation Mode

WARNING

During assembly or maintenance, and under operation in some conditions, the operators or technicians must be alert and aware of all possible pinch points or areas where there are moving or sliding components.

1. Remove the pneumatic pressure to de-energize the actuator.
2. Align the helical groove on the piston rod (2) with a groove in the adapter (54) by rotating the handwheel (63).

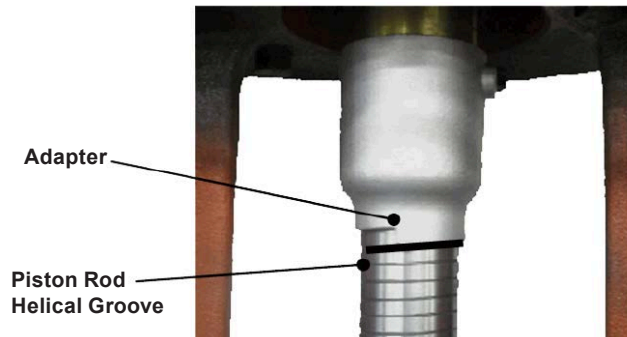

Figure 4 - Adapter and Piston Rod

3. Rotate the gearbox cover (38) in the clockwise direction while holding down the AUTO button until the MANU button releases. If the MANU button does not release, slightly rotate the handwheel until the MANU button releases.

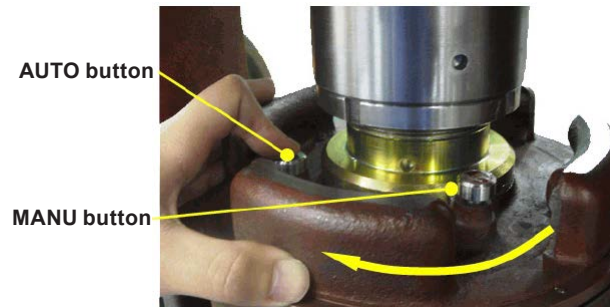

Figure 5 - Auto/Manu Buttons and Piston Screw

CAUTION

Ensure that the MANU button is fully released and the gearbox cover (38) is firmly locked at the manual position (no rotation). Sudden valve movement can occur in manual mode if the piston rod (2) power screw is disengaged.

Switching from Manual Operation to Auto Operation Mode

1. Remove the pneumatic pressure to de-energize the actuator.
2. Set the positioner input signal to the current valve position. Using the handwheel, move actuator to the de-energized position.

CAUTION

Sudden valve movement may occur if this operation is not performed.

3. Rotate the gearbox cover (38) in the counter clockwise direction while holding down the MANU button until the AUTO button releases.

CAUTION

Ensure that the AUTO button is fully released and the gearbox cover (38) is firmly locked at the auto position (no rotation). Failure of the automatic operation can occur.

Hydraulic Manual Override (Optional)

The hydraulic handjack is a secondary control system to provide the means to operate the valve when the primary pneumatic system fails. The system in one configuration is a single acting cylinder which acts against spring load. In the second configuration, the cylinder is connected in a double acting mode. The system requires no adjustments, and only minimal servicing (filling the reservoir) is required.

! NOTE

Handjack assembly is shipped with the reservoir properly filled and with a pipe plug in the reservoir breather port. Remove pipe plug and replace with breather plug prior to operation. Orient valve with breather plug to top of reservoir ([Figure 6](#)).

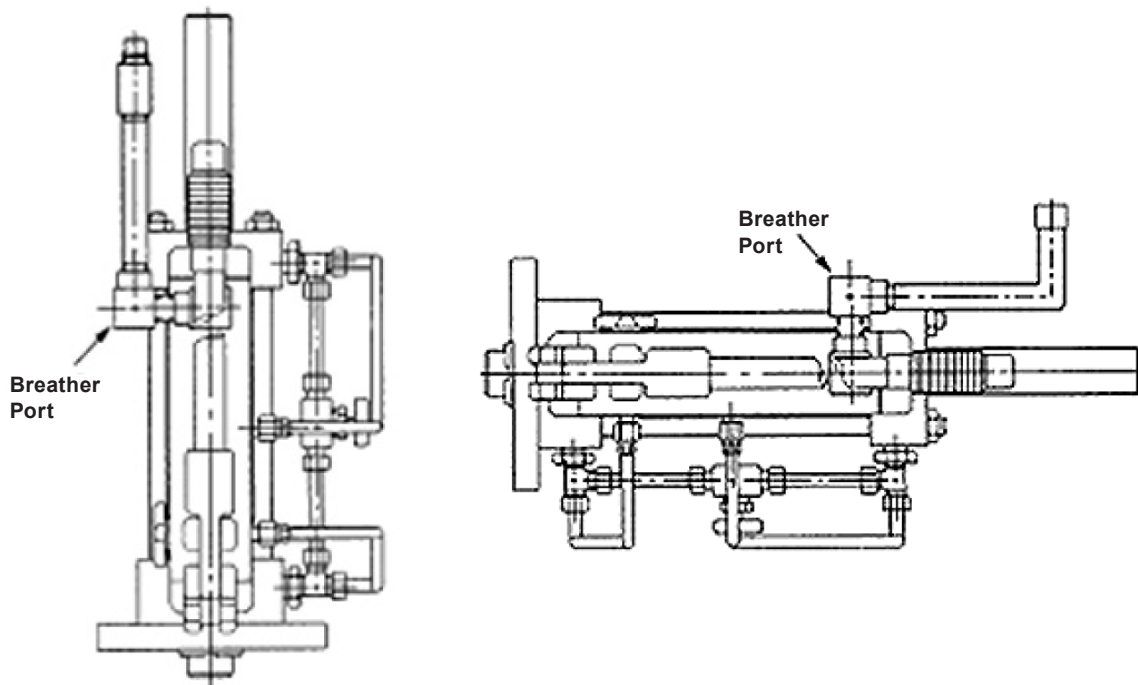

Figure 6 - Valve Installation - Vertical and Horizontal

Operation of the Manual Hydraulic Override: Air-to-Extend and Air-to-Retract Actuators

With the bypass valve closed, operating the handjack extends or retracts the stem (depending on operating mode) to its full travel position. Opening the bypass valve allows the stem to return to its normal or fail-safe position. The bypass valve must be open during pneumatic operation.

Filling the Reservoir for Single Acting and Double Acting Units

1. Remove the pipe plug from the hydraulic fluid fill hole on the pump.
2. With the actuator in its normal position (stem extended for double acting), fill the pump reservoir approximately 1/2 full with Mobil DTE 24 hydraulic fluid (or equivalent).
3. Close the pump bypass and hand operate the actuator to its full travel position, adding fluid as necessary to maintain the 1/2 full level in the reservoir. This operation assures that the hydraulic cylinder is filled with fluid.

CAUTION

Do not over fill the reservoir.

4. Install breather plug into the hydraulic fluid fill hole after the hydraulic fluid filling procedure.

Maintenance

Actuator Removal

Before removal of the valve and disassembly:

- Isolate the unit with the air supply lines to the cylinder removed and the system pressure to the valve cutoff.
- Empty the pneumatic volume tanks so that no trapped air remains in the cylinder.
- Disconnect all the electrical connections to the actuator.

Maintenance of the actuator normally requires removal of the actuator from the valve body. The steps in removal of the actuator are different depending on whether the actuator is double acting, Air-to-extend or Air-to-retract.

WARNING

Moving parts can crush or cut. Keep hands clear.

During assembly or maintenance, and under operation in some conditions, the operators or technicians must be alert and aware of all possible pinch points or areas where there are moving or sliding components.

WARNING

POTENTIAL LOSS OF CONTAINMENT / PRESSURE: The failure of properly following installation, maintenance and/or assembly /disassembly instructions may result in unsafe conditions. It is the responsibility of the end user to ensure instructions are properly followed.

LINES and FITTINGS: All lines and fittings must be properly connected and secured, and as required anchored to restrict movement.

The cylinder actuator is a spring loaded device and the disassembly instructions must be adhered to as unit or bodily damage can occur.

CAUTION

RETURNING TO SERVICE: After installation or maintenance, ensure the equipment has been properly inspected and returned to proper condition before returning to service.

LOCKOUT / TAGOUT: Proper lockout / tagout of energy sources prior to service or maintenance, must be followed according to safe site work practices, to ensure the safety of personnel conducting the work on the actuator assembly. This includes any potential control signals or circuits that may have a remote or automated control function over an actuator or component.

NOTE

Actuator action may be checked by referring to the valve identification tag. Model 51 indicates unit is double acting (no spring), Model 52 indicates unit is air-to-extend and Model 53 indicates unit is air-to-retract.

Instructions are general in nature. Check valve instructions for additional guidance. Actuator model can be determined by referring to the valve identification tag.

Double Acting (Model 51) With or Without Handwheel, With or Without Volume Chamber

1. The handwheel must be at the AUTO position, and air supply to actuator must be shut off (see “Switching from Manual Operation to Auto Operation Mode” on page 15).
2. Disconnect air piping from the top plate (17) and yoke (1), and ensure that there is no air pressure in the cylinder (Figure 7 and Figure 8).

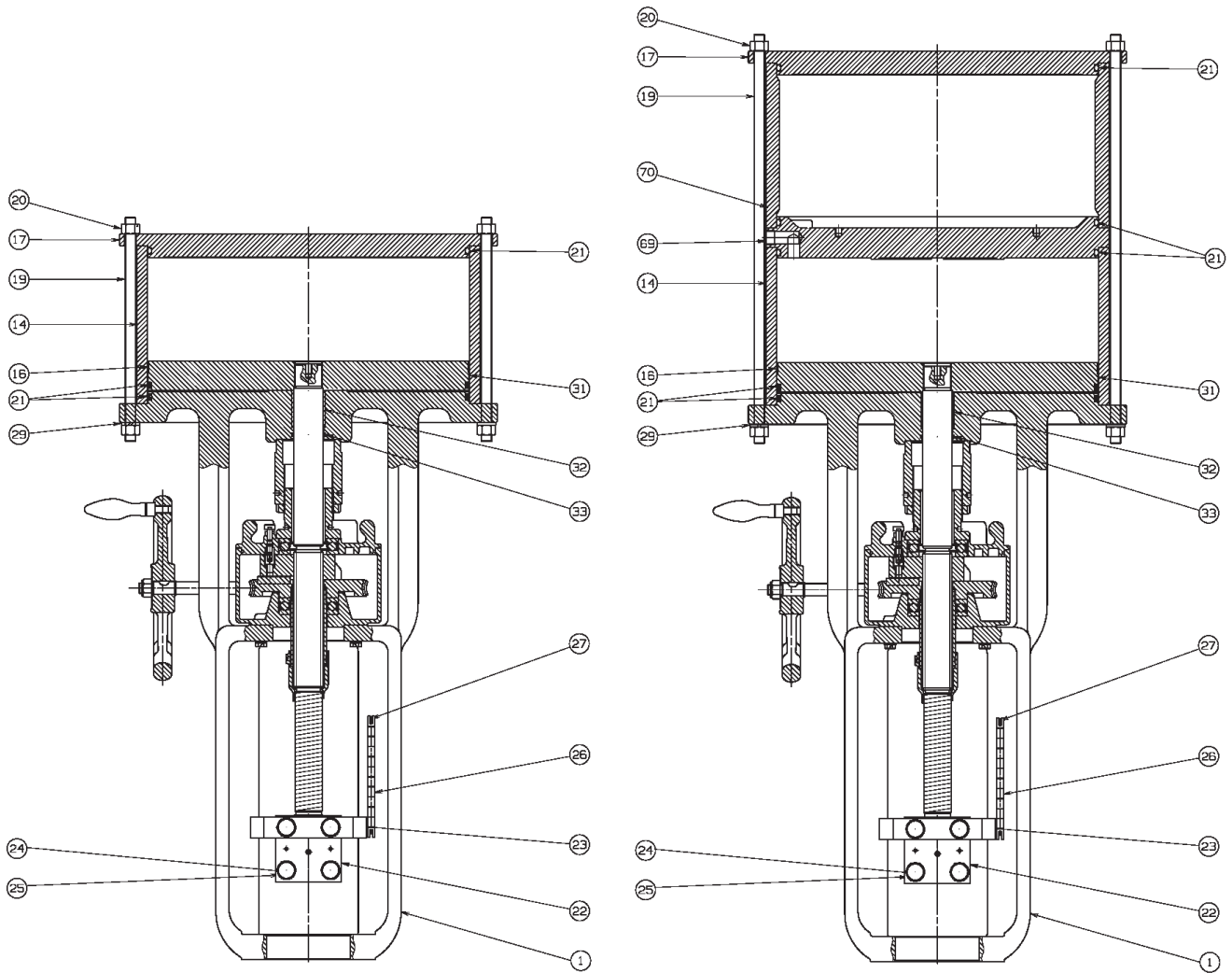

Figure 7 - Model 51 with Handwheel, With/Without Volume Chamber

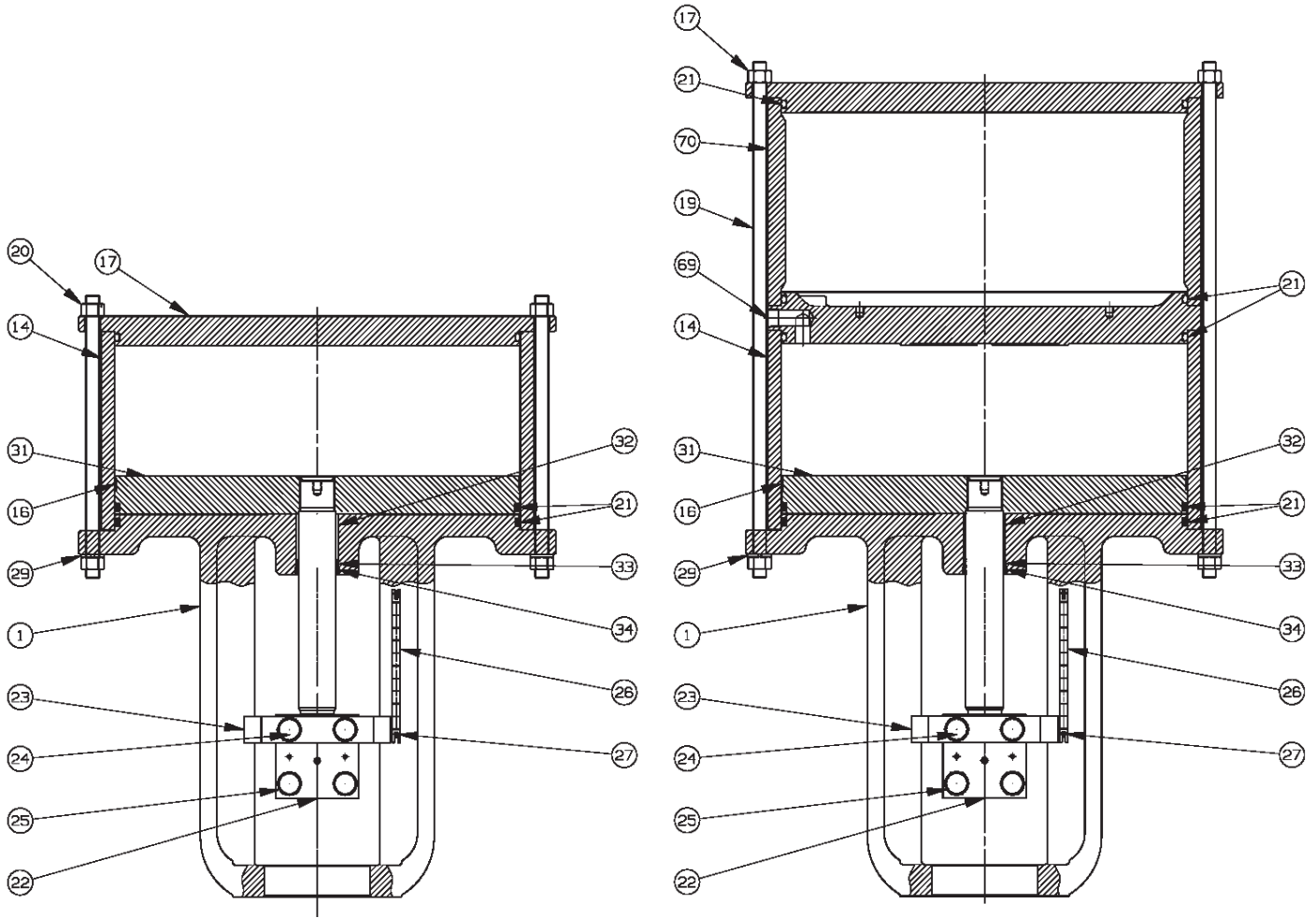

Figure 8 - Model 51 Without Handwheel, With/Without Volume Chamber

3. Loosen and remove the hexagon bolts (24) on split clamp assembly.

WARNING

Make provisions to support and lift the actuator off the body using proper lift supports and procedures.

Proper lifting techniques, equipment, procedures, per safe site work practices, are the end user's responsibility.

4. Remove the indicator arm (23) and the split clamp (22).

NOTE

Do not allow the valve plug to drop into the seat ring, since this can damage both parts.

5. Loosen and remove the valve mounting hardware and remove the actuator from the valve body.

CAUTION

Take care in handling the actuator to prevent damage to gauges, tubing and component parts.

Air-to-Extend (Model 52) With or Without Handwheel (refer to [Figure 9](#))

1. The handwheel, if equipped, must be in the AUTO position and the air supply to actuator must be shut off. (see "Switching from Manual Operation to Auto Operation Mode" on page 15).
2. Disconnect air piping from the top plate.
3. Check the valve position relative to the indicator plate (26) to ensure that the valve stem is retracted.

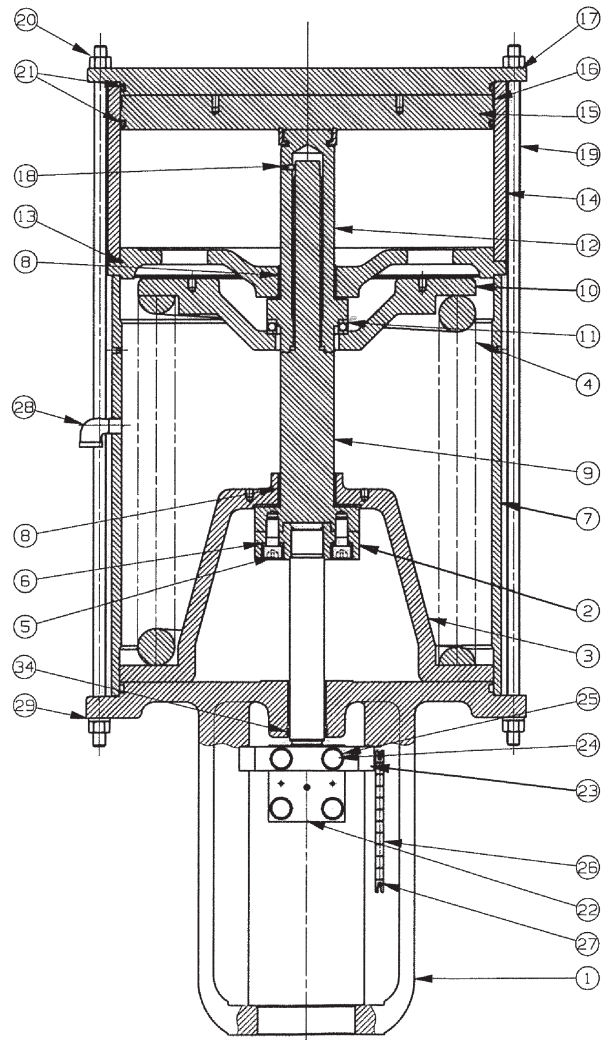
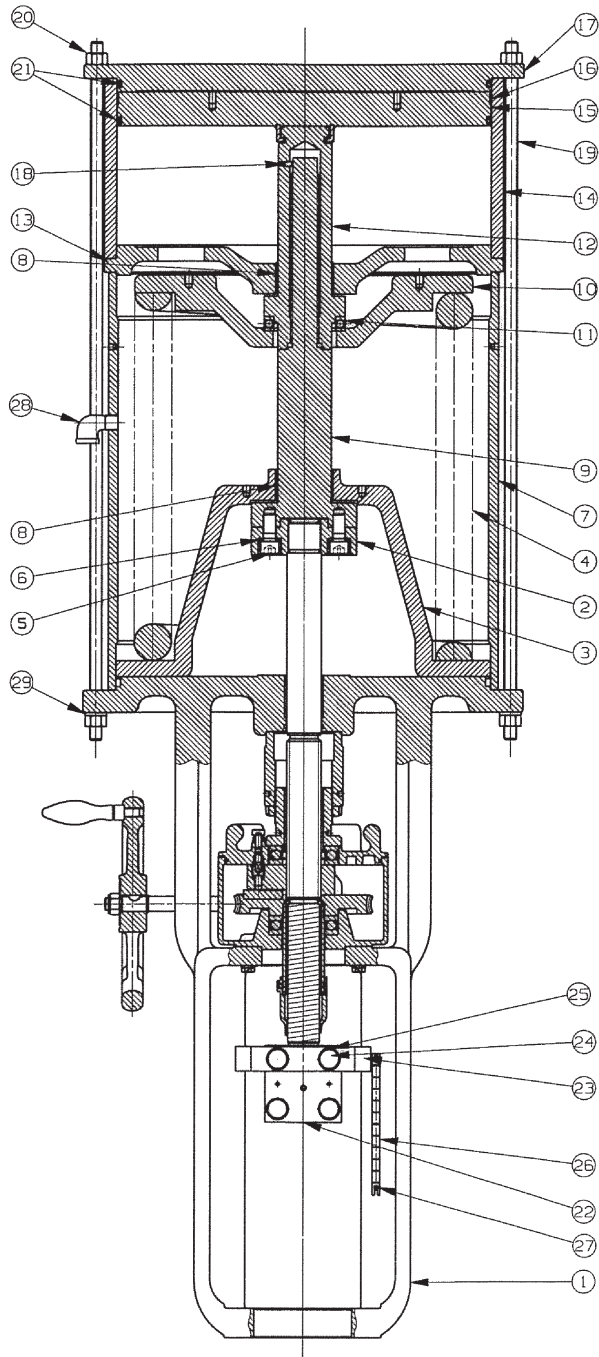

Figure 9 - Model 52 With and Without Handwheel

NOTE

No air pressure is required to the actuator since the spring force acts to open the valve.

4. Loosen and remove the four hexagon bolts (24) and split clamp.

WARNING

Make provisions to support and lift the actuator off of the body using recommended lift supports and procedures.

5. Remove the indicator arm (23) and the split clamp (22).

NOTE

Do not allow the valve plug to drop into the seat ring, since this can damage both parts.

6. Loosen and remove the valve mounting hardware and remove the actuator from the valve body.

CAUTION

Take care in handling the actuator to prevent damage to gauges, tubing and component parts.

Air-to-Retract (Model 53) With or Without Handwheel (refer to [Figure 10](#))

Since removal of the valve plug stem from the split clamp requires the valve plug to be off the seat, special provisions are necessary to assure that the valve is in the opened position.

Proceed as follows for an actuator without a handwheel.

WARNING

During assembly or maintenance, and under operation in some conditions, the operators or technicians must be alert and aware of all possible pinch points or areas where there are moving or sliding components.

NOTE

Since air supply piping connected to the actuator is normally rigid, it is recommended that a controlled pressure source with suitable flex tubing be used, or flex connections be made between the supply piping and the actuator connection to accommodate movement of the actuator.

CAUTION

High stress placed on rigid piping can cause breaking of the air supply line. A flex connector is recommended.

1. The handwheel must be in the AUTO position, and the air supply to the actuator must be shut off (see “Switching from Manual Operation to Auto Operation Mode” on page 15).
2. Disconnect air supply piping to the actuator.
3. Connect a controlled pressure source to the yoke (1) air supply connector.

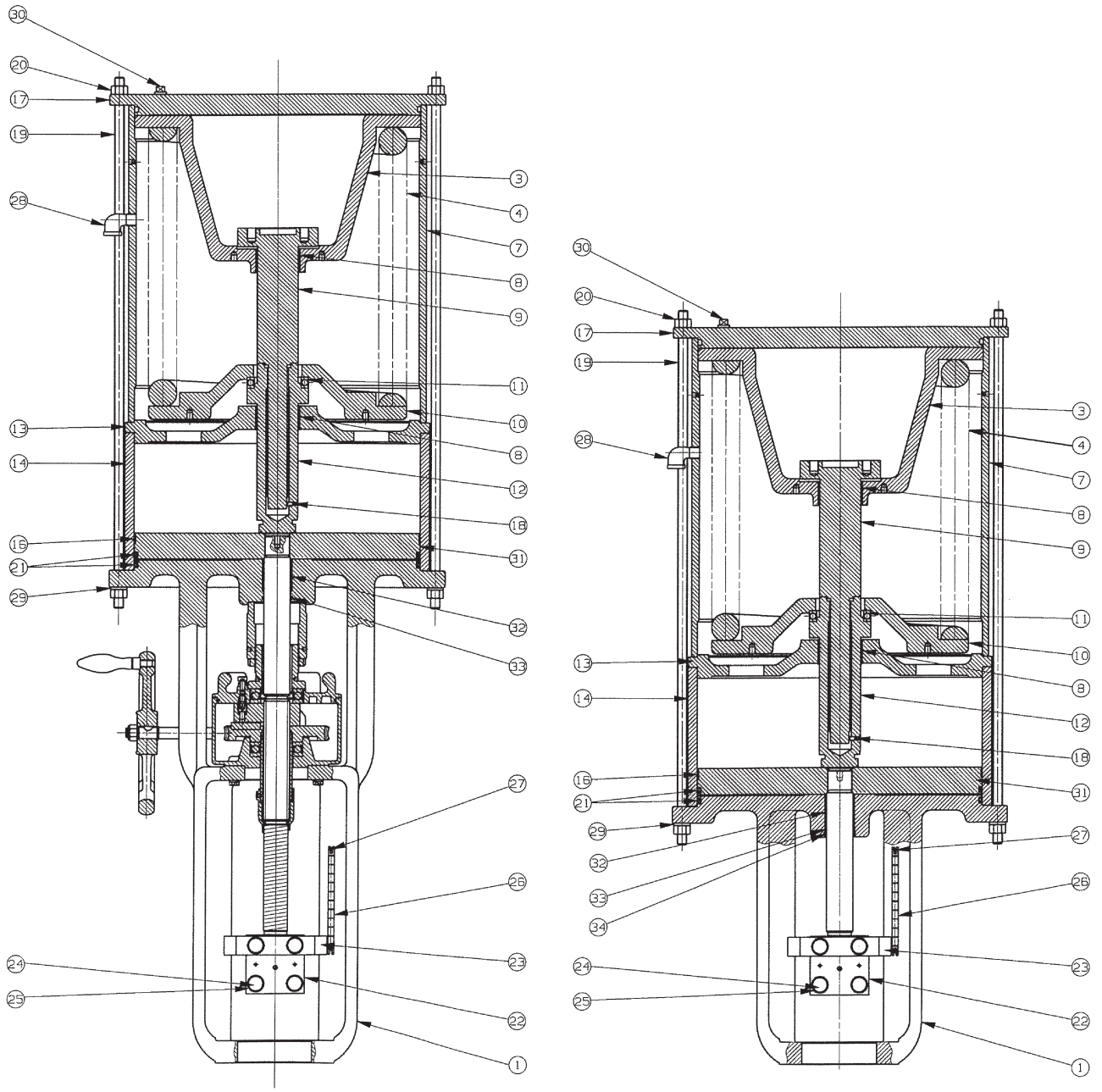

Figure 10 - Model 53 With and Without Handwheel

4. Apply required air pressure to open the valve as is indicated by the stem position relative to the indicator plate (26).

CAUTION

High stress placed on rigid piping can cause breaking of the air supply line. A flex connector is recommended.

WARNING

Make provisions to support and lift the actuator off the body using recommended lift supports and procedures.

5. Loosen and remove hexagon bolts (24) and split clamp.
6. Remove the indicator arm (23) and the split clamp (22).

NOTE

Do not allow the valve plug to drop into the seat ring, since this can damage both parts.

7. Loosen and remove the valve mounting hardware and remove the actuator from the valve body.

CAUTION

Take care in handling the actuator to prevent damage to gauges, tubing and component parts. In addition, since a flex connection may be made between the actuator and air piping, do not exert pressure on the flex tubing or air piping.

8. Release the air pressure from actuator.

Maintenance Procedures

There are different maintenance steps required, depending on whether the actuator is double acting, air-to-extend or air-to-retract.

NOTE

Actuator action may be checked by referring to the valve identification tag. Model 51 indicates unit is double acting (no spring), Model 52 indicates unit is air-to-extend and Model 53 indicates unit is air-to-retract.

CAUTION

Place the actuators in an upright position for all disassembly or assembly operations.

Model 51 O-ring, Guide Ring Replacement - Double Acting With or Without Handwheel

WARNING

During assembly or maintenance, and under operation in some conditions, the operators or technicians must be alert and aware of all possible pinch points or areas where there are moving or sliding components.

1. The handwheel must be in the AUTO position (see “Switching from Manual Operation to Auto Operation Mode” on page 15).
2. Shut off air supply to the actuator, and isolate the process pressure from the valve to prevent plug movement ([Figure 7](#) on page 19).
3. Disconnect air piping from the top plate (17), separator plate (69), and check for air pressure in the cylinder.
4. Remove the hexagon nuts (20), spring lock washers (29), and center bolts (19).
5. For models:
 - **With volume chamber:** Remove top plate (17), volume chamber tube (70), separator plate (69), cylinder tube (14), O-rings (21), guide ring (16).
 - **Without volume chamber:** Remove top plate (17), cylinder tube (14), O-rings (21), guide ring (16).
 - **With double piston:** Remove top plate (17), upper cylinder nut (20) spring washer (6), upper piston plate (31), separator plate (69), lower cylinder tube (14), O-rings (21), and guide ring (16).
6. Loosen set screw (55) in adapter (54) and unscrew adapter (54) from spacer tube (5).
7. Remove piston subassembly (31).

CAUTION

Ensure that guide bushing inner surface (32) is not scratched by piston subassembly thread (31).

8. Replace O-ring (33) in yoke with new part. Coat the O-ring with silicone grease (or equivalent).
9. Replace piston subassembly (31). Coat silicone grease (or equivalent) on the sliding surface of the piston rod.

CAUTION

Ensure that guide bushing inner surface (32) is not scratched by piston subassembly thread (31).

10. Replace O-rings (21) and guide ring (16) with new parts. Coat the O-ring and guide ring with silicone grease (or equivalent).
11. Replace cylinder tube (14), separator plate (69), volume chamber tube (70), top plate (17). Coat the inner surface of the cylinder tube with silicone grease (or equivalent).
12. Ensure the positions of the air connections are correct. Insert the center bolts into the holes of the top plate and yoke. Mount the spring washers and nuts and tighten them lightly by hand. Mount the spring washers and nuts to the bottom side of the yoke by hand. Ensure that the position of center bolts (approximately +25 mm longer than others) for the accessory mounting plate, if equipped, complies with [Figure 11](#).

Position for standard air connection

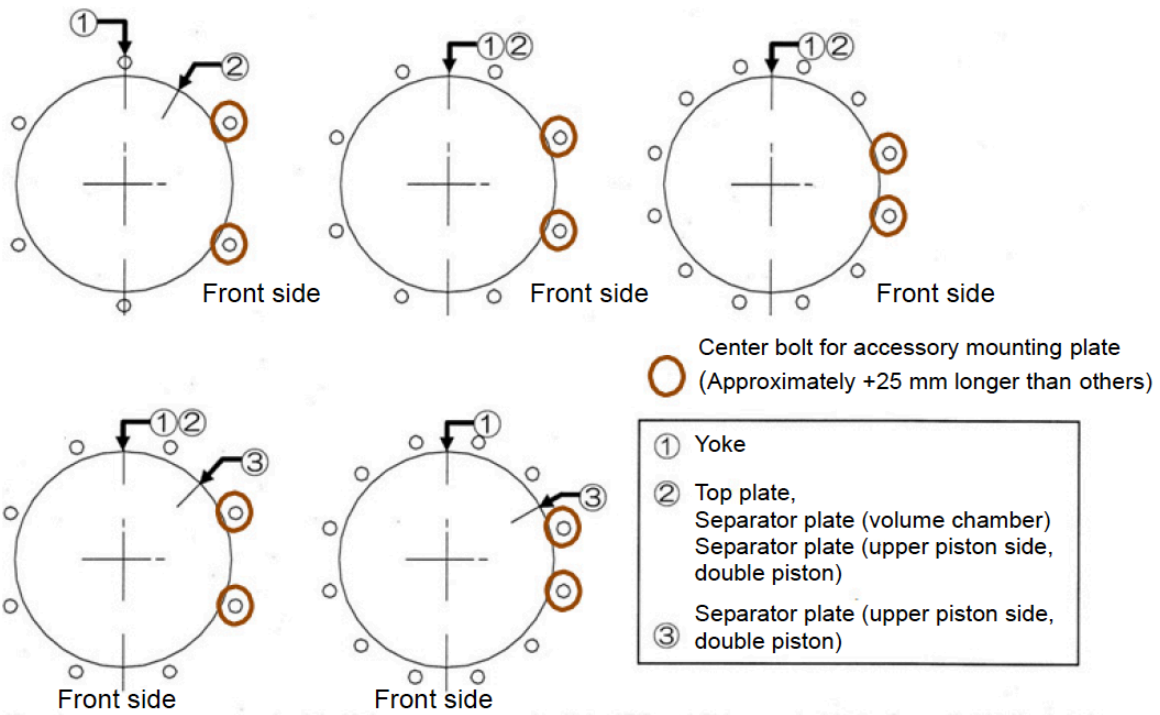

Figure 11 - Center bolt Positioning

13. Align the holes of the top plate with the yoke so that the center bolts are set vertically.
14. Ensure balanced tightening of the center bolt by tightening the nuts in diagonal pairs gradually to a torque of:

Carbon Steel		Stainless Steel	
M16	70 N-m (52.0 ± 4ft-lbs)	M16	150 N-m (110.6 ± 4ft-lbs)
M20	160 N-m (118.0 ± 4ft-lbs)	M20	250 N-m (180.4 ± 4ft-lbs)
M24	270 N-m (199.1 ± 4ft-lbs)	M24	420 N-m (309.8 ± 4ft-lbs)

Model 52 O-ring, Guide Ring Replacement - Air-to-Extend with Handwheel

WARNING

During assembly or maintenance, and under operation in some conditions, the operators or technicians must be alert and aware of all possible pinch points or areas where there are moving or sliding components.

1. The handwheel must be in the AUTO position. (see "Switching from Manual Operation to Auto Operation Mode" on page 15).
2. Shut off air supply to the actuator, and isolate the process pressure from the valve.
3. Disconnect air piping from the top plate ([Figure 8](#) on page 20).
4. Remove the hexagon nuts (20), spring lock washers (29), and center bolts (19). Disassemble the hex nuts (20).
5. Remove the top plate (17) and cylinder tube (14), carefully avoiding any horizontal misalignment.

NOTE

Take care while handling the cylinder tube (14), since the piston plate subassembly (15) will be loose (see "Model 51 O-ring, Guide Ring Replacement - Double Acting With or Without Handwheel" on page 26).

6. Replace the O-ring (21) on the top plate (17) and the O-ring (21) and guide ring (16) on the piston plate S/A (15) with new parts. Coat the O-rings and guide ring with silicone grease (or equivalent). Coat the sliding surface of the compression bolt with industrial grease (not silicone grease).

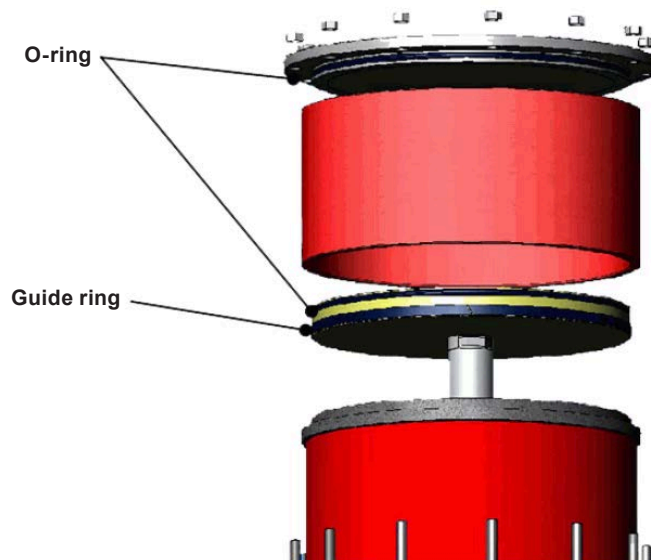

Figure 12 - Model 52 O-ring and guide ring

7. Replace cylinder tube (14), and top plate (17) with only axial movement. Coat the inner surface of the cylinder tube with silicone grease.

- Ensure the positions of the air connections are correct. Insert the center bolts into the holes of the top plate and yoke. Mount the spring washers and nuts and tighten them lightly by hand. Mount the spring washers and nuts to the bottom side of the yoke by hand. Ensure that the position of center bolts (Approximately +25 mm longer than others) for the accessory mounting plate, if equipped, complies with [Figure 13](#).

Position for standard air connection

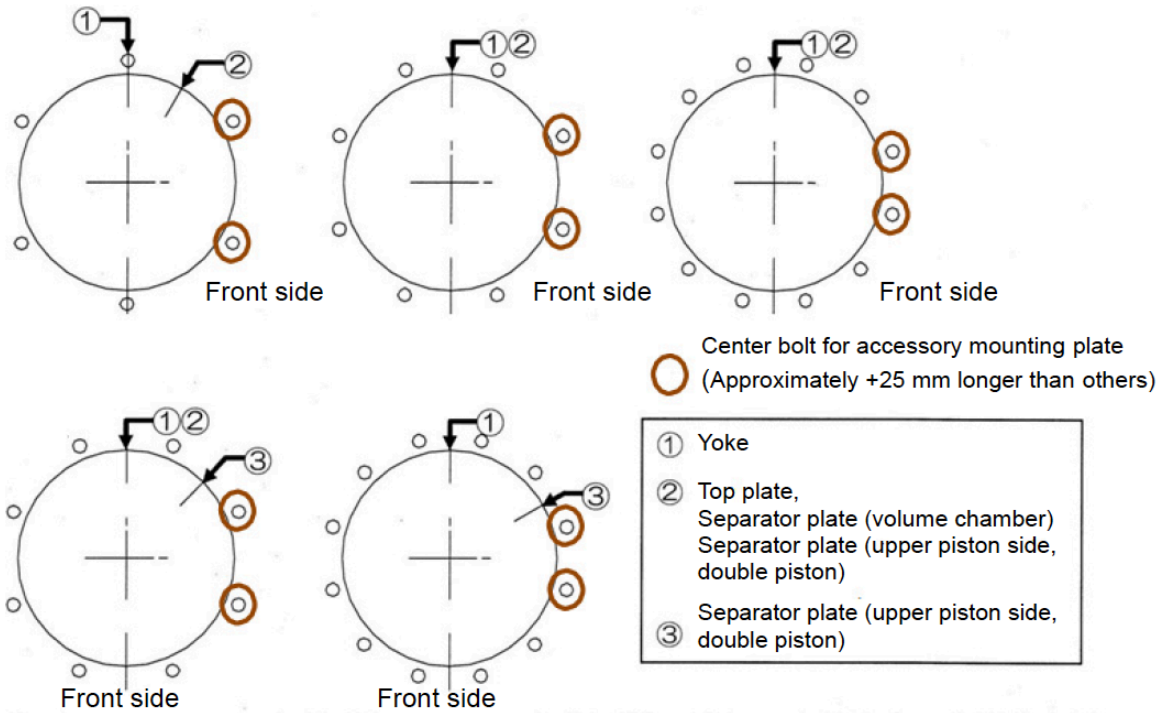

Figure 13 - Center bolt Positioning

- Align the holes of the top plate with the yoke so that the center bolts are set vertically.
- Ensure balanced tightening of the center bolts by tightening the nuts in diagonal pairs gradually to a torque of 70.0 ± 5 N-m (52.0 ± 4 ft-lbs).

Model 52 O-ring, guide ring and rod scraper replacement - Air-to-extend without handwheel

WARNING

During assembly or maintenance, and under operation in some conditions, the operators or technicians must be alert and aware of all possible pinch points or areas where there are moving or sliding components.

1. Shut off the air supply to the actuator, and isolate the process pressure from the valve.
2. Disconnect supply piping from the top plate (17) ([Figure 9](#) on page 22).
3. Remove the indicator arm (23), split clamp (22), hexagon bolts (24) and spring lock washers (25).
4. Remove the hexagon nuts (20), spring lock washers (29), and center bolts (19).
5. Remove the top plate (17) and cylinder tube (14), carefully avoiding any horizontal misalignment.

CAUTION

Take care while handling the cylinder tube (14), since the piston plate S/A (15) can fall out (see “Model 51 O-ring, Guide Ring Replacement - Double Acting With or Without Handwheel” on page 26).

6. Replace the O-ring (21) on the top plate (17) and the O-ring (21) and guide ring (16) on the piston plate (15) with new parts. Coat the O-rings and guide ring with silicone grease (or equivalent).
7. Rotate the piston plate subassembly (15) until the chamfer in the compression nut (12) aligns with the stop collar opening in the piston plate subassembly.

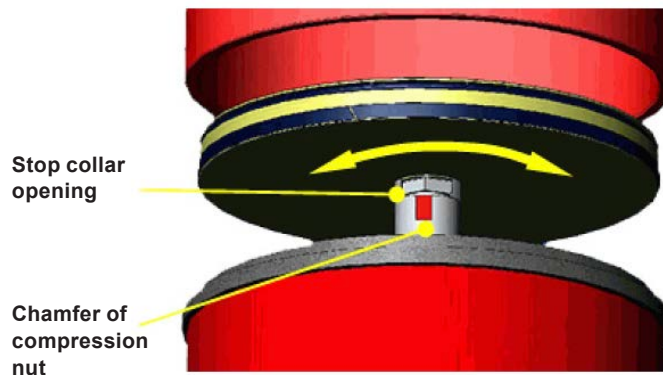

Figure 14 - Stop Collar Opening

8. Remove piston plate subassembly (15) in the direction of the arrow.

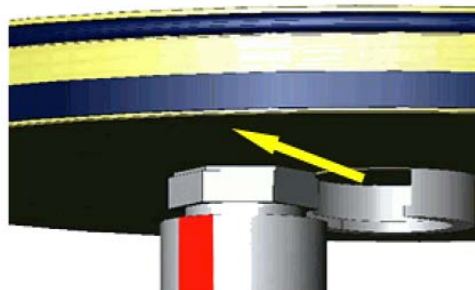

Figure 15 - Piston Subassembly Removal

9. Remove separator plate (13), spring tube (7) and spring subassembly.

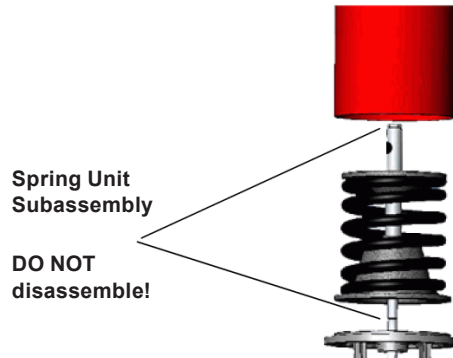

Figure 16 - Spring Subassembly Removal

CAUTION

Be careful not to damage the inner surface of the guide bushing (8) with the compression nut (12) during assembly and disassembly..

10. Replace the rod scraper (34) with a new part. Coat the rod scraper with silicone (or equivalent).
11. Replace spring unit, spring tube (7), separator plate (13), piston subassembly (15).
12. Replace the O-ring (21) on the top plate (17) and the O-ring (21) and guide ring (16) on the piston plate S/A (15) with new parts. Coat the O-rings and guide ring with silicone grease (or equivalent).
13. Replace cylinder tube (14), and top plate (17) with only axial movement. Coat the inner surface of the cylinder tube with silicone grease.

14. Ensure the positions of the air connections are correct. Insert the center bolts into the holes of the top plate and yoke. Mount the spring washers and nuts and tighten them lightly by hand. Mount the spring washers and nuts to the bottom side of the yoke by hand. Ensure that the position of center bolts (approximately +25 mm longer than others) for the accessory mounting plate, if equipped, complies with [Figure 17](#).

Position for standard air connection

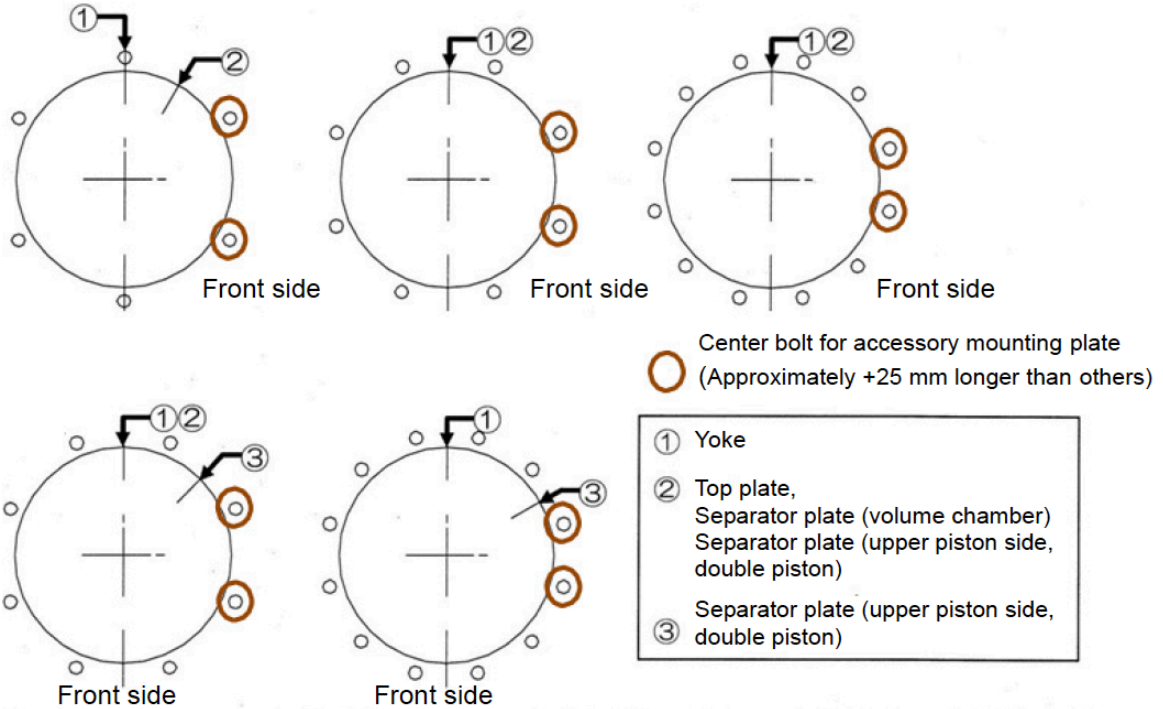

Figure 17 - Center bolt Positioning

15. Align the holes of the top plate with the yoke so that the center bolts are set vertically.
16. Ensure balanced tightening of the center bolt by tightening the nuts in diagonal pairs gradually to a torque $70.0 \pm 5 \text{ N-m}$ ($52.0 \pm 4 \text{ ft-lbs}$).

Model 53 O-ring and Guide Ring Replacement - Air-to-Retract with Handwheel

WARNING

During assembly or maintenance, and under operation in some conditions, the operators or technicians must be alert and aware of all possible pinch points or areas where there are moving or sliding components.

1. The handwheel must be in the AUTO position (see "Switching from Manual Operation to Auto Operation Mode" on page 15).
2. Shut off the air supply to the actuator, and isolate the process pressure from the valve.
3. Remove the indicator arm (23), split clamp (22), hexagon bolts (24) and spring lock washers (25) ([Figure 10](#) on page 24). Remove the hexagon nuts (20), spring lock washers (29), and center bolts (19).
5. Remove top plate (17), spring tube (7), and spring unit.

CAUTION

Be careful not to damage the inner surface of the guide bushing (8) with the compression nut (12) during assembly and disassembly.

6. Remove separator plate (13), cylinder tube (14), O-ring (21), guide ring (16).
7. Remove piston subassembly (31)

CAUTION

Ensure that guide bushing inner surface (32) is not scratched by the piston subassembly screw (31).

8. Unscrew locking nut (42) and adjustment nut (43).
9. Replace O-ring (33) on piston rod with new part. Coat the O-ring with silicone grease (or equivalent).
10. Replace adjustment nut (43) and tighten locking nut (42).
11. Replace piston subassembly (31).

CAUTION

Ensure that guide bushing inner surface (32) is not scratched by the piston subassembly screw (31).

12. Replace O-ring (21), and guide ring (16) with new parts. Coat the O-ring and guide ring with silicone grease (or equivalent).

13. Replace cylinder tube (14) and separator plate (13). Coat the inner surface of the cylinder tube with silicone grease.
14. Replace spring unit, spring tube (7), and top plate (17). Coat the sliding surface of the piston rod with silicone grease (or equivalent).

CAUTION

Ensure that guide bushing inner surface (8) is not scratched by compression nut (12).

15. Ensure the positions of the air connections are correct. Insert the center bolts into the holes of the top plate and yoke. Mount the spring washers and nuts and tighten them lightly by hand. Mount the spring washers and nuts to the bottom side of the yoke by hand. Ensure that the position of center bolts (approximately +25 mm longer than others) for the accessory mounting plate, if equipped, complies with [Figure 18](#).

Position for standard air connection

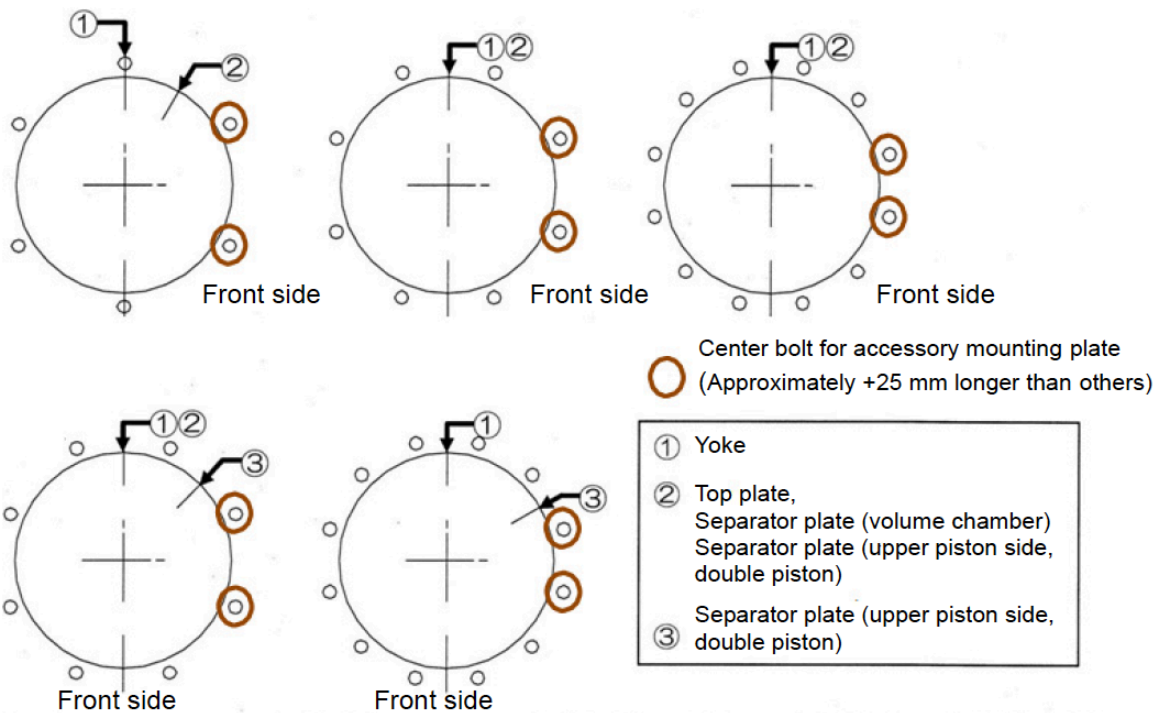

Figure 18 - Center bolt Positioning

16. Align the holes of the top plate with the yoke so that the center bolts are set vertically.
17. Ensure balanced tightening of the center bolt by tightening the nuts in diagonal pairs gradually to a torque 70.0 ± 5 N-m (52.0 ± 4 ft-lbs).

Model 53 O-ring, Guide Ring and Rod Scraper Replacement - Air-to-Retract Without Handwheel

WARNING

During assembly or maintenance, and under operation in some conditions, the operators or technicians must be alert and aware of all possible pinch points or areas where there are moving or sliding components.

1. Shut off the air supply to the actuator, and isolate the process pressure from the valve.
2. Remove the indicator arm (23), split clamp (22), hexagon bolts (24) and spring lock washers (25) ([Figure 10](#) on page 24)
3. Remove the hexagon nuts (20), spring lock washers (29), and center bolts (19). Disassemble the hex nuts (20) in small increments using an alternating diagonal pattern to slowly relieve the spring tension.
4. Remove top plate (17), spring tube (7), and spring unit.

CAUTION

Ensure that guide bushing inner surface (8) is not scratched by compression nut (12).

5. Remove separator plate (13), cylinder tube (14), O-ring (21), guide ring (16).
6. Remove piston subassembly (31).

CAUTION

Ensure that guide bushing inner surface (32) is not scratched by the piston subassembly screw (31).

7. Replace O-ring (33) and rod scraper (34) with new parts. Coat the O-ring and rod scraper with silicone grease (or equivalent).
8. Replace piston subassembly (31).

CAUTION

Ensure that guide bushing inner surface (32) is not scratched by the piston subassembly screw (31).

9. Replace O-ring (21) and guide ring (16) with new parts. Coat the O-ring and guide ring with silicone grease (or equivalent).
10. Replace cylinder tube (14) and separator plate (13). Coat silicone grease on the inner surface of the cylinder tube.

- Replace spring unit, spring tube (7), and top plate (17). Coat the sliding surface of the compression bolt with industrial grease (no silicone grease).

CAUTION

Ensure that guide bushing inner surface (8) is not scratched by compression nut (12).

- Ensure the positions of the air connections are correct. Insert the center bolts into the holes of the top plate and yoke. Mount the spring washers and nuts and tighten them lightly by hand. Mount the spring washers and nuts to the bottom side of the yoke by hand. Ensure that the position of center bolts (approximately +25 mm longer than others) for the accessory mounting plate, if equipped, complies with [Figure 19](#).

Position for standard air connection

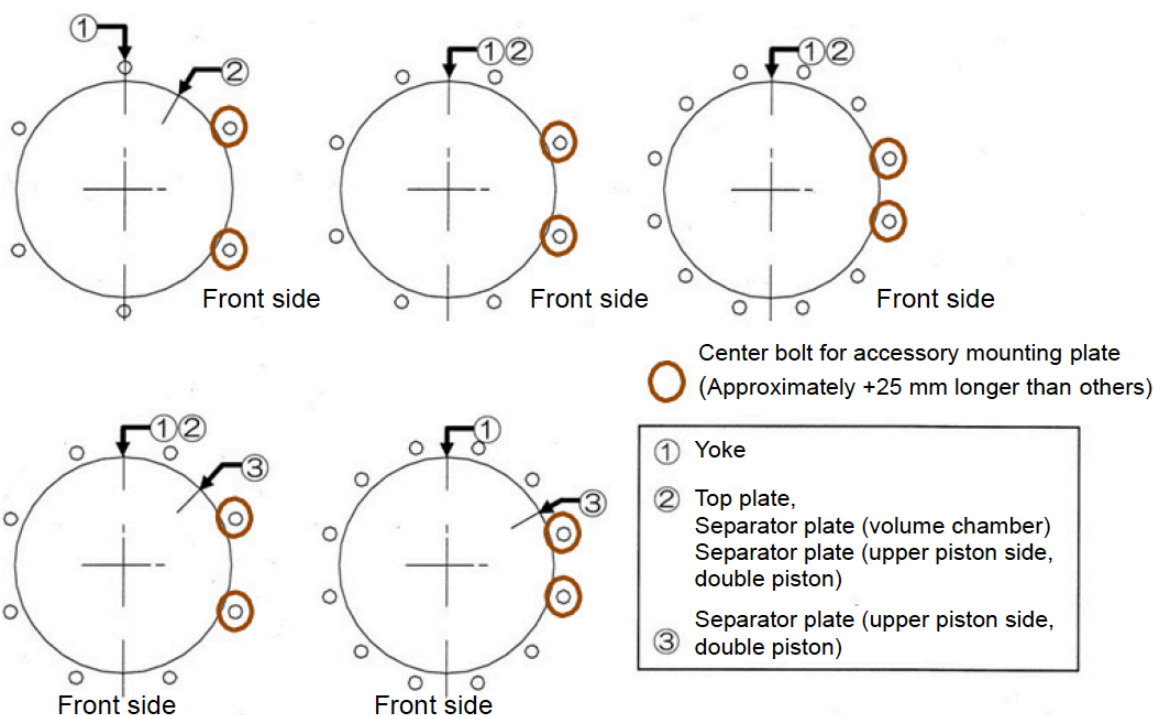

Figure 19 - Center bolt Positioning

- Align the holes of the top plate with the yoke so that the center bolts are set vertically.
- Ensure balanced tightening of the center bolt by tightening the nuts in diagonal pairs gradually to a torque $70.0 \pm 5 \text{ N}\cdot\text{m}$ ($52.0 \pm 4 \text{ ft}\cdot\text{lbs}$).

Spring Cartridge Removal

The spring cartridge ([Figure 20](#)) must be disassembled whenever the actuator is permanently taken out of service (before being discarded).

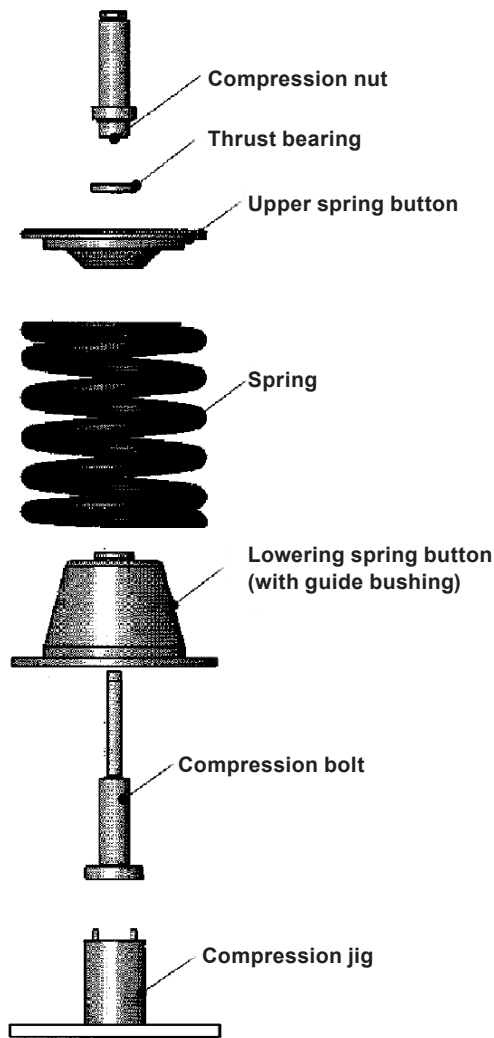
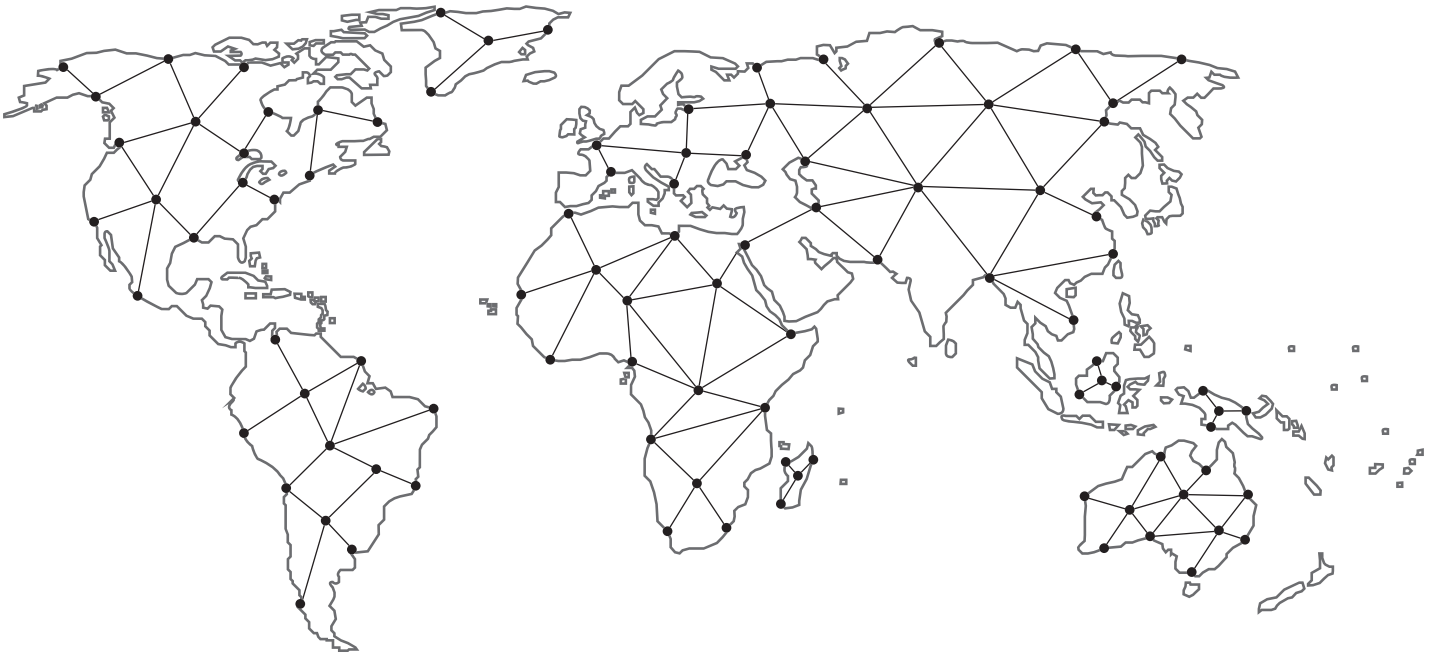

Figure 20 - Spring Cartridge Assembly

1. Remove the actuator according to “Actuator Removal” on page 18.
2. Remove the spring subassembly by following the model-specific procedure:
 - For Model 52, follow “Model 52 O-ring, Guide Ring and Rod Scraper Replacement - Air-to-Extend Without Handwheel” on page 30 through step 9.
 - For Model 53, follow “Model 53 O-ring, Guide Ring and Rod Scraper Replacement - Air-to-Retract Without Handwheel” on page 33 or “Model 53 O-ring, Guide Ring and Rod Scraper Replacement - Air-to-Retract Without Handwheel” on page 33 through step 4.
3. Loosen and remove compression nut (12) from compression bolt (9). Use a compression jig (not supplied with actuator) or other device to prevent compression bolt rotation.

Find the nearest local Channel Partner in your area:

valves.bakerhughes.com/contact-us



Tech Field Support and Warranty:

Phone: +1-866-827-5378

valvesupport@bakerhughes.com

valves.bakerhughes.com

Copyright 2024 Baker Hughes Company. All rights reserved. Baker Hughes provides this information on an "as is" basis for general information purposes. Baker Hughes does not make any representation as to the accuracy or completeness of the information and makes no warranties of any kind, specific, implied or oral, to the fullest extent permissible by law, including those of merchantability and fitness for a particular purpose or use. Baker Hughes hereby disclaims any and all liability for any direct, indirect, consequential or special damages, claims for lost profits, or third party claims arising from the use of the information, whether a claim is asserted in contract, tort, or otherwise. Baker Hughes reserves the right to make changes in specifications and features shown herein, or discontinue the product described at any time without notice or obligation. Contact your Baker Hughes representative for the most current information. The Baker Hughes logo and Masoneilan are trademarks of Baker Hughes Company. Other company names and product names used in this document are the registered trademarks or trademarks of their respective owners.

Baker Hughes 

bakerhughes.com