

75000 Series Tank Mount Control Valve

Model: 51-75683 (With #12 to #32 Cylinder Actuator)

Instruction Manual (Rev. A)



THESE INSTRUCTIONS PROVIDE THE CUSTOMER/OPERATOR WITH IMPORTANT PROJECT-SPECIFIC REFERENCE INFORMATION IN ADDITION TO THE CUSTOMER/OPERATOR'S NORMAL OPERATION AND MAINTENANCE PROCEDURES. SINCE OPERATION AND MAINTENANCE PHILOSOPHIES VARY, BAKER HUGHES COMPANY (AND ITS SUBSIDIARIES AND AFFILIATES) DOES NOT ATTEMPT TO DICTATE SPECIFIC PROCEDURES, BUT TO PROVIDE BASIC LIMITATIONS AND REQUIREMENTS CREATED BY THE TYPE OF EQUIPMENT PROVIDED.

THESE INSTRUCTIONS ASSUME THAT OPERATORS ALREADY HAVE A GENERAL UNDERSTANDING OF THE REQUIREMENTS FOR SAFE OPERATION OF MECHANICAL AND ELECTRICAL EQUIPMENT IN POTENTIALLY HAZARDOUS ENVIRONMENTS. THEREFORE, THESE INSTRUCTIONS SHOULD BE INTERPRETED AND APPLIED IN CONJUNCTION WITH THE SAFETY RULES AND REGULATIONS APPLICABLE AT THE SITE AND THE PARTICULAR REQUIREMENTS FOR OPERATION OF OTHER EQUIPMENT AT THE SITE.

THESE INSTRUCTIONS DO NOT PURPORT TO COVER ALL DETAILS OR VARIATIONS IN EQUIPMENT NOR TO PROVIDE FOR EVERY POSSIBLE CONTINGENCY TO BE MET IN CONNECTION WITH INSTALLATION, OPERATION OR MAINTENANCE. SHOULD FURTHER INFORMATION BE DESIRED OR SHOULD PARTICULAR PROBLEMS ARISE WHICH ARE NOT COVERED SUFFICIENTLY FOR THE CUSTOMER/OPERATOR'S PURPOSES THE MATTER SHOULD BE REFERRED TO BAKER HUGHES.

THE RIGHTS, OBLIGATIONS AND LIABILITIES OF BAKER HUGHES AND THE CUSTOMER/OPERATOR ARE STRICTLY LIMITED TO THOSE EXPRESSLY PROVIDED IN THE CONTRACT RELATING TO THE SUPPLY OF THE EQUIPMENT. NO ADDITIONAL REPRESENTATIONS OR WARRANTIES BY BAKER HUGHES REGARDING THE EQUIPMENT OR ITS USE ARE GIVEN OR IMPLIED BY THE ISSUE OF THESE INSTRUCTIONS.

THESE INSTRUCTIONS ARE FURNISHED TO THE CUSTOMER/OPERATOR SOLELY TO ASSIST IN THE INSTALLATION, TESTING, OPERATION, AND/OR MAINTENANCE OF THE EQUIPMENT DESCRIBED. THIS DOCUMENT SHALL NOT BE REPRODUCED IN WHOLE OR IN PART WITHOUT THE WRITTEN APPROVAL OF BAKER HUGHES.

Safety Information

Important - Please read before installation

These instructions contain **DANGER**, **WARNING**, and **CAUTION** labels, where necessary, to alert you to safety related or other important information. Read the instructions carefully before installing and maintaining your control valve. **DANGER** and **WARNING** hazards are related to personal injury. **CAUTION** hazards involve equipment or property damage. Operation of damaged equipment can, under certain operational conditions, result in degraded process system performance that can lead to injury or death. Total compliance with all **DANGER**, **WARNING**, and **CAUTION** notices is required for safe operation.



This is the safety alert symbol. It alerts you to potential personal injury hazards. Obey all safety messages that follow this symbol to avoid possible injury or death.



Indicates a potentially hazardous situation which, if not avoided, could result in death or serious injury.



Indicates a potentially hazardous situation which, if not avoided, could result in serious injury.



Indicates a potentially hazardous situation which, if not avoided, could result in minor or moderate injury.



When used without the safety alert symbol, indicates a potentially hazardous situation which, if not avoided, could result in property damage.

Note: Indicates important facts and conditions.

About this Manual

- The information in this manual is subject to change without prior notice.
- The information contained in this manual, in whole or part, shall not be transcribed or copied without Baker Hughes's written permission.
- Please report any errors or questions about the information in this manual to your local supplier.
- These instructions are written specifically for the **Masoneilan™** 75000 Series control valve, and do not apply for other valves outside of this product line.

Useful Life

The current estimated useful life period for the 75000 Series control valve is 25+ years. To maximize the useful life of the product, it is essential to conduct annual inspections, routine maintenance and ensure proper installation to avoid any unintended stresses on the product. The specific operating conditions will also impact the useful life of the product. Consult the factory for guidance on specific applications if required prior to installation.

Warranty

Items sold by Baker Hughes are warranted to be free from defects in materials and workmanship for a period of one year from the date of shipment provided said items are used according to Baker Hughes recommended usages. Baker Hughes reserves the right to discontinue manufacture of any product or change product materials, design or specifications without notice. This instruction manual applies to the Masoneilan 75000 Series control valve.

Note: Prior to installation:

- The valve must be installed, put into service and maintained by qualified and competent professionals who have undergone suitable training.
- All surrounding pipelines must be thoroughly flushed to ensure all entrained debris has been removed from the system.
- Under certain operating conditions, the use of damaged equipment could cause a degradation of the performance of the system which may lead to personal injury or death.
- Changes to specifications, structure, and components used may not lead to the revision of this manual unless such changes affect the function and performance of the product.

General

These instructions apply to the 75000 Series tank mount type control valves.

For the construction of the valve body, please refer to the drawings MNS139003 and MNS 139006, on page 3 and 4. For the cylinder actuator, side handwheel, and other components, refer to the respective instructions.

This control valve is designed to be mounted directly on a container like storage tank, and the seat ring and the plug are to be installed from the bottom of the valve body. The valve operates such that it "closes as the stem rises".

WARNING

To prevent any equipment damage or troubles, follow the instructions below.

- a) The valve must not be used when exceeding the applied regulations, standards and criterion.
- b) The valve must not be used in any condition other than the agreed specifications.
- c) If the heat transfer medium in the jacket is an incompressible fluid, do not increase the pressure above the agreed specification or expand the fluid when closing the inlets/outlets of the jacket. Please refer to the drawing MNS-139006 on page 4.

Installation

Prior to installing the valve, clean the piping of all foreign matter such as dirt, welding chips, scale, oil or grease. Install the valve to the piping so that the fluid flows in the direction indicated by the flow arrows attached to the body, or the fluid flows from "IN" toward "OUT" marked at the connection point. When securing the lower flange to the tank, press the seat ring against the body until it enters the connection port of the tank. Be careful so that the seat ring is not pressed too hard against the inner surface of the connection port of the tank.

When the valve is installed in a horizontal position, be sure to support the yoke or another part of the actuator.

In case of the extension type body, do not apply insulation to the extended portion.

Provide the required air tubing for the signal pressure and air supply, and the electrical wiring to the positioner. Make sure there are no air leaks from the piping.

Maintenance

When the control valve needs to be disassembled for inspection, cleaning or polishing the valve seat, follow the procedures described below.

The following procedure is according to the drawings MNS139003 and MNS 139006, on page 3 and 4.

Disassembly

Shut off all the air supplies, and disconnect the tubings for the air supply and the positioner signal pressure, and the air tubing from the volume tank.

To disassemble the valve, it must be removed from the piping. Bring a chain block over the valve to remove it from the piping for disassembly and for reinstallation.

1. Run a strong rope through the actuator yoke and remove the valve retaining bolts from the piping while slightly pulling the valve upward.

If the valve is installed in a horizontal position, also run a rope around the body so that no excessive force is exerted on the seat ring in the tank, when disconnecting the valve from the tank.

2. Remove the positioner linkage from the split clamp (18) which connects the piston rod (19) of actuator and the plug (13) of the body side. Loosen the nut (16) or the bolt (26), depending on the assembly method of the split clamp (see drawing MNS-139003 & MNS-139006), to remove the split clamp (18). Record the depth of the stem in the split clamp and the position of the split clamp so that they can be reassembled to the same dimension. Loosen the set screws (28) for easy reassembly.
3. Remove the nuts(27) from the plug. Remove the plug (13), followed by the seat ring (12) from the bottom of the body. The actuator can be removed by loosening the drive nut (5), which connects the body (10) and the yoke (14). If the yoke is connected to the body with the stud (23) and nut (24), loosen the nut (24) to remove the actuator from the body.

Polishing the Valve Seat

When the valve seat needs polishing, install the seat ring (12) and plug (13) from the bottom of the body (10), and tentatively hand-tighten them to the body. Lightly press the plug (13) against the seat side from the bottom of the body (10), hold the plug with a wrench at the wrench holder, and polish the seating surface. Polishing the seating surface too hard may damage the seating surface. When polishing the seating surface, apply a fine-grain, quality abrasive to it. Thoroughly clean the seating surface prior to reinstallation.

Reassembly

When reassembling the valve, replace the gland packing (6) and gasket (11) with new ones where possible. If the valve is gasketless, remove all foreign objects such as dirt, grease, etc. Reassembly is basically done by reversing the process of disassembly. However, the following steps for reassembly should be taken:

CAUTION

If the flange is a threaded type, it must be screwed about 5 mm from the body's end to give adequate compression to the gasket. Please refer to figure 1.

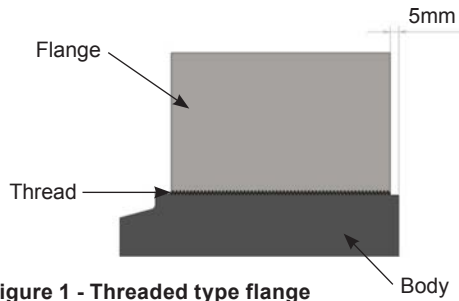

Figure 1 - Threaded type flange

1. Reinstall the seat ring (12) followed by the plug (13) from the bottom of the body (10).
2. Install the packing (6), pushing it along the stem portion of the plug (13).
When installing the packing, be sure to rotate the cut end 180 degrees from the previous piece and push them into position with the packing follower (4).
3. When the body is reassembled, install the actuator.
4. Tentatively hand-tighten the seat ring (12) to the body (10). Apply an air pressure lower than the supply pressure to the bottom of the actuator piston to set the valve to a closed position, and carefully seat the plug on the seating surface of the seat ring.
5. Reinstall the nuts(27) to a position where it does not interfere with the assembly of the split clamp (18). Connect the piston rod (19) and plug (13) with the split clamp(18). The flat cut on the plug stem should face the frontside of the split clamp. (The engagement length of both the threads should roughly be the same) Make sure the threads of the piston rod and the plug perfectly engage with those of the split clamp. When they are perfectly engaged, lightly tighten the nut (16) or the bolt (26) of the split clamp.

CAUTION

When assembling the split clamp to the plug stem and piston rod, follow the instructions below.

- a) **Before assembly, confirm the threads are free of any foreign objects. If there are any objects, remove it by cleaning and airblowing the threads.**
- b) **Do not use any lubricants on the threads of the stems.**
- c) **If there are any brackets for accessories mounted on the split clamp, the split clamp must first be securely assembled before mounting the brackets.**

6. Pressurize the top of the actuator piston so that the plug (13) is lowered away from the seat. Turn the plug (13) 180 degrees clockwise (move the plug up toward the actuator) to obtain an adequate seating clearance. After turning the plug, the flat cut on the plug stem should face the backside of the split clamp (the same side as the thread for the set screw). Use the 3 indications on the stem as a reference on where the flat cut is. The value recorded in disassembly would be of help. Fully tighten the split clamp (18), with the following torque:

M12 (#12) : 25~30 N·m、M16 (#16-28A) : 55~70 N·m
UNC3/4 (#32) : 285~340 N·m

Lock the 2 nuts (27) together by using proper tools. The nut should not touch the bottom of the split clamp.

Screw in a set screw (28) against the flat cut of the plug stem as a prevention for rotation. Screw in a second set screw (28) to keep the first one from loosening.

Connect the positioner linkage to the split clamp.

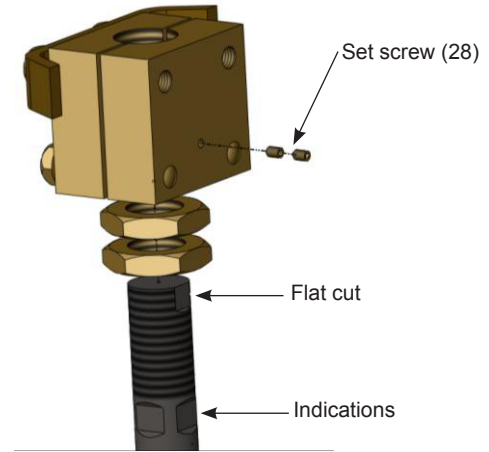

Figure 2 - Anti-rotation measure with single lock nut

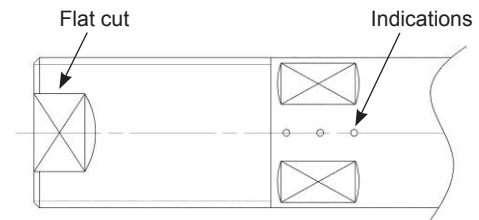

Figure 3 - Indications on the plug stem

7. Install the valve to the piping, referring to the procedure for installation.
8. Connect all the air tubings.

Reassembly is now completed. Prior to operation, be sure to check for the valve action, openings, etc.

Polishing the Valve Seat

Periodically conduct a maintenance check of the packing box.

The sealing performance of the packing is maintained by compressing the packing.

Compression is obtained by evenly tightening the packing flange stud nut (2) for the packing flange(3).

But please be aware that tightening the packing flange too much may result in stiff actuation. If the leak does not stop after complete compression, new packings are necessary.

75683 Series Tank Mount Valve Sectional Drawing

DWG. No.: MNS-139003

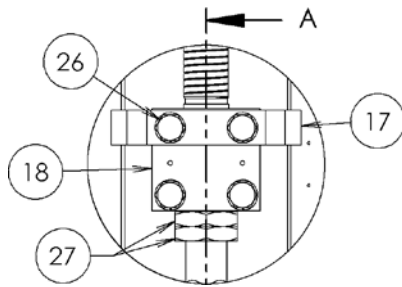

Split Clamp's Detail
For Actuator Size #12-#28

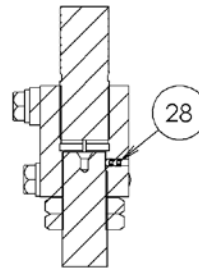

Section A-A

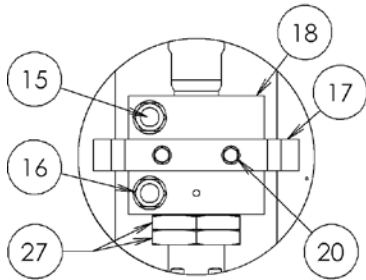

Split Clamp's Detail
For Actuator Size #32

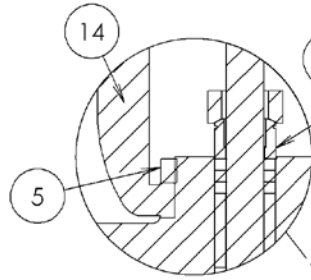

Other Connection Type

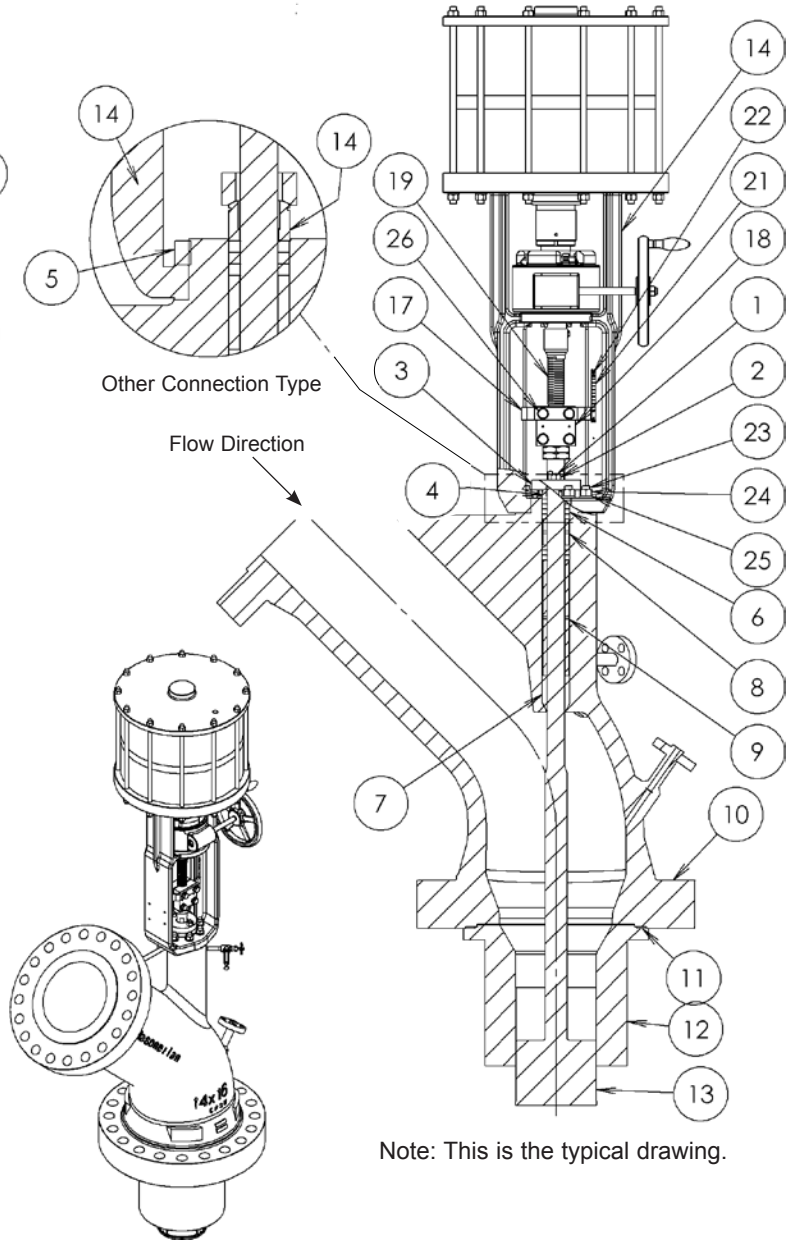

Note: This is the typical drawing.

Item No.	Description
1	Packing Flange Stud
2	Packing Flange Stud Nut
3	Packing Flange
4	Packing Follower
5	Drive Nut
6	Packing
7	Guide Bushing
8	Lantern Ring
9	Lantern Ring
10	Body
11	Gasket
12	Seat Ring
13	Plug
14	Yoke
15	Stud
16	Nut
17	Indicator Arm
18	Split Clamp
19	Piston Rod
20	Bolt
21	Indicator
22	Screw
23	Stud
24	Nut
25	Spring Washer
26	Bolt
27	Hex. Nut
28	Set Screw

75683 Series Tank Mount Valve Sectional Drawing

DWG. No.: MNS-139006

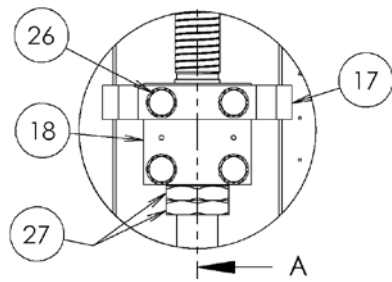

Split Clamp's Detail
For Actuator Size #12-#28

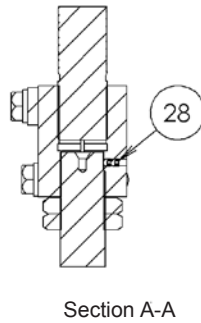

Section A-A

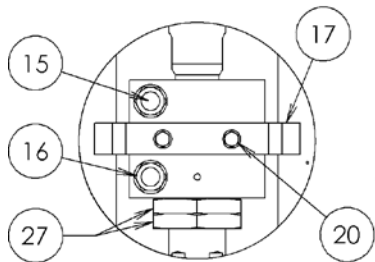

Split Clamp's Detail
For Actuator Size #32

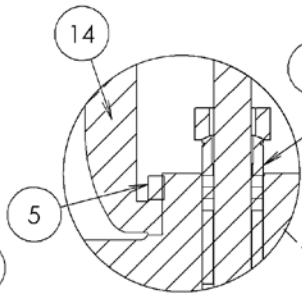

Other Connection Type

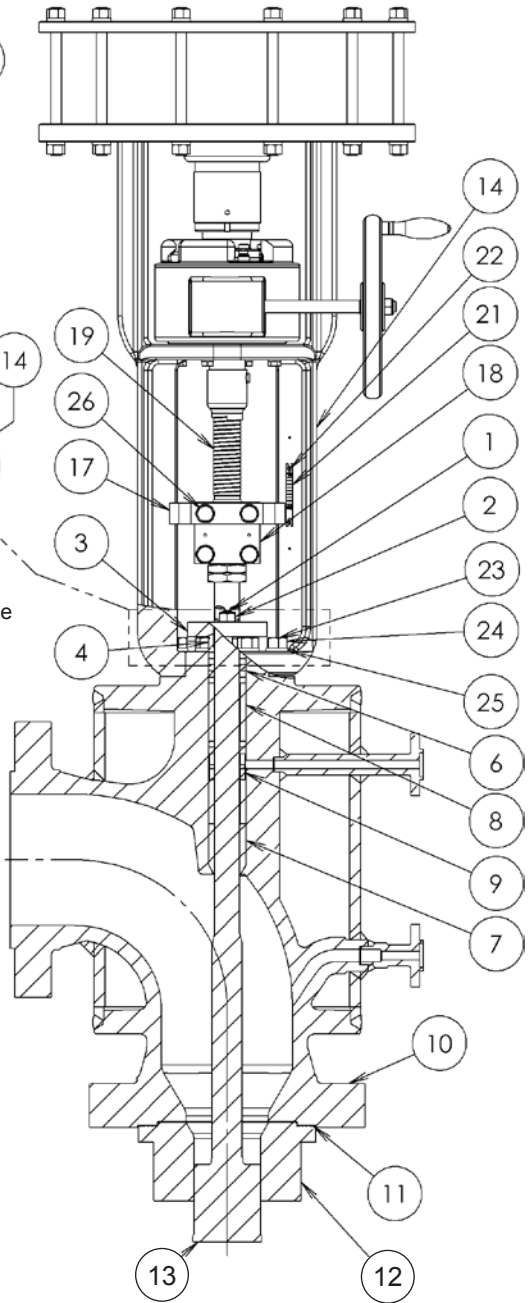

Flow Direction →

Note: This is the typical drawing.

Item No.	Description
1	Packing Flange Stud
2	Packing Flange Stud Nut
3	Packing Flange
4	Packing Follower
5	Drive Nut
6	Packing
7	Guide Bushing
8	Lantern Ring
9	Lantern Ring
10	Body
11	Gasket
12	Seat Ring
13	Plug
14	Yoke
15	Stud
16	Nut
17	Indicator Arm
18	Split Clamp
19	Piston Rod
20	Bolt
21	Indicator
22	Screw
23	Stud
24	Nut
25	Spring Washer
26	Bolt
27	Hex. Nut
28	Set Screw

Find the nearest local Channel Partner in your area:

valves.bakerhughes.com/contact-us

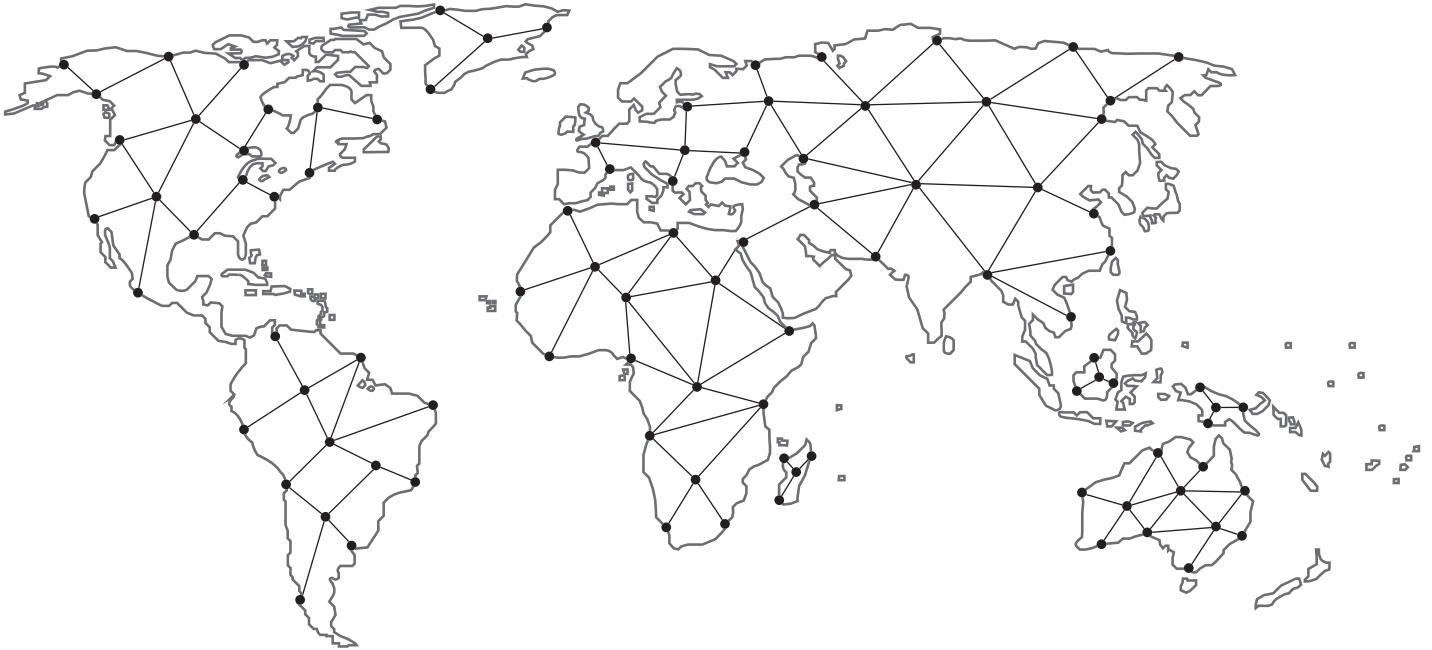

Tech Field Support & Warranty:

Phone: +1-866-827-5378

valvesupport@bakerhughes.com

valves.bakerhughes.com

Copyright 2021 Baker Hughes Company. All rights reserved. Baker Hughes provides this information on an "as is" basis for general information purposes. Baker Hughes does not make any representation as to the accuracy or completeness of the information and makes no warranties of any kind, specific, implied or oral, to the fullest extent permissible by law, including those of merchantability and fitness for a particular purpose or use. Baker Hughes hereby disclaims any and all liability for any direct, indirect, consequential or special damages, claims for lost profits, or third party claims arising from the use of the information, whether a claim is asserted in contract, tort, or otherwise. Baker Hughes reserves the right to make changes in specifications and features shown herein, or discontinue the product described at any time without notice or obligation. Contact your Baker Hughes representative for the most current information. The Baker Hughes logo and Masoneilan are trademarks of Baker Hughes Company. Other company names and product names used in this document are the registered trademarks or trademarks of their respective owners.

Baker Hughes 

bakerhughes.com