

DPI610E

Portable Pressure Calibrator Instruction Manual

All Variants



Preface



INFORMATION Read this manual carefully before use. Keep for future reference.

Druck multifunction calibrators are an all-in-one solution for your pressure measurement and generation applications. The DPI610E is a multifunction process calibrator containing pressure and vacuum generation capabilities.

We offer different variants of the calibrator:

DPI610E-A (Aero), DPI610E and DPI610E-IS (Intrinsically Safe).

The DPI610E-IS instrument is for use in areas that can have an explosive atmosphere. The other models must not be used in this type of area.

The calibrator can do many tasks, for example:

- to read and make voltage, current, frequency, and resistance signals
- to make records of data and the automation of calibration procedures
- to test and calibrate electrical equipment, pressure sensors, gauges, switches, thermocouples, RTDs, and other types of equipment.

The DPI610E-A (Aero) can do leak tests of aircraft pitot and static systems.

Safety









WARNING Do not apply pressure greater than the maximum safe working pressure.

It is dangerous to attach an external source of pressure to the DPI610E. Use only the internal mechanisms to set and control pressure in the pressure calibrator.

This equipment is safe when you use the procedures in this manual. Do not use this equipment for any other purpose than that specified. This is because the protection given by the equipment can be reduced or canceled.

Symbols

Symbol	Description
	This equipment is compatible with the requirements of all related European safety directives. The equipment has the CE mark.
	This equipment is compatible with the requirements of all related UK Statutory legal standards. The equipment has the UKCA mark.
	<p>This symbol on the equipment, identifies a warning and that the user must refer to the user manual.</p> <p>Ce symbole, sur l'appareil, est un avertissement qui indique que l'utilisateur doit consulter le manuel d'utilisation.</p>
	USB ports: Type A; Mini Type B connector.
	Ground (Earth)
	DC adapter polarity: the center of the plug is negative.
	<p>Druck is an active member of Europe's Waste Electrical and Electronic Equipment (WEEE) take-back program (directive 2012/19/EU).</p> <p>This equipment that you have bought has used natural resources in its production. Possibly it can have hazardous substances that can have a bad effect on health and the environment.</p> <p>To stop the return of these dangerous substances into our environment and to reduce the demand for natural resources, we encourage you to use the correct take-back systems. Those systems will reuse or recycle most of the materials of your discarded equipment. The crossed-out wheeled bin symbol shows that this instrument is to be discarded safely.</p> <p>Please write to your local or regional waste administration if you need more information on the collection, reuse, and recycling systems.</p> <p>Please use the link below for take-back instructions and more information about this program.</p>



<https://druck.com/weee>

Acronyms and Abbreviations

This manual uses these acronyms and abbreviations. Abbreviations are the same in the singular and plural.

Acronyms and Abbreviation	Description	Acronyms and Abbreviation	Description
a	Absolute	m	Meter
ac	Alternating Current	mA	milliampere
bar	Unit of pressure	max	Maximum
bara	bar - absolute	mbar	millibar
bard	bar - differential	min	Minute or minimum
barg	bar - gauge	MSDS	Material Safety Data Sheet
CH	Channel	NPT	National Pipe Thread
CJ	Cold Junction	PA	Process Automation
COSHH	Control of Substances Hazardous to Health	P/N	Part Number
dc	Direct current	PIN	Personal Identification Number
DD	Device Description	POTD	Pressure of the day
DPI	Digital Pressure Instrument	psi	Pounds per square inch
DUT	Device Under Test	QFE	Query: Field Elevation
e.g.	For example	QNH	Query: Nautical Height
FS	Full Scale	RH	Relative Humidity
ft	Foot	RS-232	Serial communications standard
g	Gauge	TC	Thermocouple
H ₂ O	Water	USB	Universal Serial Bus
Hz	Hertz	V	Volts
i.e.	That is	VCP	Virtual Communications Port
in	Inch	°C	Degrees Celsius
IS	Intrinsically Safe	°F	Degrees Fahrenheit
kg	kilogram		

Contents

1.	Overview	1
1.1	DPI610E Series	1
1.1.1	Firmware Versions	1
1.1.2	DPI610E Variants	2
1.1.3	Equipment in the Package	3
1.2	Specifications and Accessories for DPI610E	4
1.3	Use of Manual	4
1.4	Safety	5
1.4.1	General Safety Precautions	5
1.4.2	Software Configuration and Security	5
1.4.3	Operation in a Dangerous Area	5
1.4.4	General Warnings	6
1.4.5	Electrical Warning	6
1.4.6	Pressure Warnings	6
1.4.7	Overvoltage Categories	7
1.5	Maintenance	7
1.5.1	Visual Inspection	7
1.5.2	How to Clean the Instrument	7
1.5.3	Calibration	8
1.6	Service and Repair	8
1.7	Spares	8
1.8	Instrument Return	8
1.8.1	Returned Goods Procedure	8
1.8.2	How to Discard the Instrument	8
1.9	Packaging for Storage or Transportation	9
1.9.1	Environment	9
1.10	How to Prepare the Instrument	9
1.10.1	Initial Checks	9
1.11	Battery and Charging	9
1.11.1	Battery Status Indicator	10
1.12	Power ON and OFF	10
1.12.1	Power ON	10
1.12.2	Power OFF	10
1.12.3	Auto Power Down	10
1.13	Parts	11
1.13.1	Pneumatic Instruments	11
1.13.2	Hydraulic Instruments	12
1.13.3	Test Port	12
1.13.4	Reservoir (Hydraulic Version)	13
1.13.5	Pressure Release Valve	13
1.13.6	Electrical Connections	13
1.13.7	Let-down Valve (DPI610E-A)	13
1.13.8	Pump (Pneumatic Version)	13
1.13.9	Priming Pump (Hydraulic Version)	13
1.13.10	Volume Adjuster (Pneumatic Version)	13
1.13.11	Volume Adjuster Wheel (Hydraulic Version only)	13
1.13.12	Pressure/Vacuum Selector (Pneumatic Version only)	13
1.13.13	Auxiliary Ports	13
1.13.14	External Sensor Port	13

1.13.15	Barometric Port (Pneumatic Version only)	14
1.14	User Interface	14
1.14.1	Buttons and Softkeys	14
1.15	First Use	15
1.16	Dashboard	15
1.16.1	Dashboard Softkeys	16
1.16.2	Dashboard Navigation	16
1.16.3	Set Date, Time and Language	16
2.	Pump Operations	19
2.1	Pneumatic System	19
2.1.1	Using the Blanking Plug	19
2.1.2	Flexible Hose	19
2.1.3	How to Vent to Atmosphere	19
2.1.4	To Attach the Instrument Dirt Trap to the Test Port	20
2.1.5	To Attach the Device Under Test	20
2.1.6	To Remove the Device Under Test	21
2.1.7	To Prepare the Instrument for Pressure/Vacuum Operation	21
2.1.8	To Supply Medium Pressure or Vacuum	22
2.2	Hydraulic System	24
2.2.1	How to Fill the Reservoir	24
2.2.2	How to Prime the Instrument	26
2.2.3	How to Adjust Pressure	31
2.2.4	How to Release Pressure	31
2.2.5	How to Achieve 400 bar	31
2.2.6	To Replace the Fluid in the Hydraulic System	31
3.	Basic Tasks	33
3.1	Tasks	33
3.1.1	P - I (Pressure to Current measure)	33
3.1.2	P - P (Pressure to Pressure)	33
3.1.3	P - V (Pressure to Voltage)	33
3.1.4	I - P (Current to Pressure)	34
3.1.5	P - Display (Pressure to Display)	34
3.1.6	Leak Test	34
3.1.7	Switch Test	34
3.1.8	TX SIM (Transmitter Simulation)	34
3.1.9	Relief Valve Test	34
3.2	Tasks Selection	34
3.3	How to Add Tasks to the Dashboard	35
3.4	How to Remove Tasks from the Dashboard	35
4.	General Settings	37
4.1	DATE, TIME and LANGUAGE	37
4.2	BACKLIGHT	37
4.3	COMMUNICATIONS	38
4.4	AUTO POWER DOWN	38
4.5	TOUCHSCREEN LOCK	39
4.6	ENABLE HOLD	39
4.7	ADVANCED	40

5.	Advanced Menu	41
5.1	CALIBRATION Menu	41
5.2	CHANGE PIN	41
5.3	SOFTWARE UPGRADE	42
	5.3.1 How to load a Software Upgrade File	42
	5.3.2 How to Upgrade the Firmware	44
5.4	FACTORY RESET	45
5.5	FORMAT FILE SYSTEM	46
5.6	SERVICE / ENGINEERING	46
6.	Calibrator Tasks	47
6.1	Calibrator Task Screen	47
6.2	Calibrator Tasks Screen Shortcuts	48
	6.2.1 Maximize and Minimize Channel Window - Using the Touchscreen	48
	6.2.2 Maximize and Minimize Channel Window - Using the Navigation Pad	48
	6.2.3 Change Measurement Units	49
	6.2.4 10 V/24 V Loop Power Enable/Disable	51
	6.2.5 Error Indications	52
6.3	Functions	54
	6.3.1 Functions Available by Channel	54
	6.3.2 None	55
	6.3.3 Pressure	55
	6.3.4 Sum	60
	6.3.5 Difference	62
	6.3.6 Barometer	63
	6.3.7 Observed	64
	6.3.8 RTD	65
	6.3.9 Current	65
	6.3.10 Current Source Automation Options	69
	6.3.11 NUDGE	70
	6.3.12 SPAN CHECK	71
	6.3.13 PERCENT STEP	73
	6.3.14 DEFINED STEP	74
	6.3.15 RAMP	76
	6.3.16 Voltage	77
	6.3.17 Millivolts Measure - Setup	79
	6.3.18 HART	80
6.4	Process Options	82
	6.4.1 Tare	82
	6.4.2 Min/Max/Mean	83
	6.4.3 Filter	85
	6.4.4 Flow	87
	6.4.5 Alarm	88
	6.4.6 Scaling	90
7.	Utilities	95
7.1	Leak Test	95
7.2	Switch Test	98
7.3	TX (Transmitter Simulation) Simulator	100
7.4	Relief Valve Test	102

8.	The DPI610E-A Instrument	105
8.1	How to Vent the Instrument to Atmosphere	105
8.2	Controls and Connection	106
8.3	Pressure of the Day (POTD) Correction	106
8.4	Altitude Leak Test	106
8.4.1	How to Set and do an Altitude Leak Test	106
8.5	Altitude Switch Test	111
8.5.1	How to do an Altitude Switch Test (Accessible Switch Contacts)	112
8.5.2	How to do an Altitude Switch Test (Non-accessible Switch Contacts)	115
8.6	Airspeed Leak Test	118
8.6.1	How to Set and do an Airspeed Leak Test	118
8.7	Airspeed Switch Test	122
8.7.1	How to do an Airspeed Switch Test (Accessible Switch Contacts)	122
8.7.2	Method (Non-accessible Switch Contacts)	125
9.	External Sensors	131
9.1	PM700E	131
9.1.1	Overview	131
9.1.2	Media Compatibility	131
9.1.3	Setup	131
9.1.4	The Zero Function	132
9.1.5	Available External Pressure Sensors	132
9.1.6	How to set an External Pressure Sensor	133
9.2	RTD Probe and Interface	136
9.2.1	Overview	136
9.2.2	Temperature Considerations	137
9.2.3	Setup	137
9.2.4	Setup of a Channel for a RTD Sensor	139
9.2.5	RTD Profiles	140
9.3	The ADROIT Sensor	142
9.3.1	Overview	142
9.3.2	Setup of an ADROIT Sensor	143
9.3.3	ADROIT CALIBRATION	145
9.3.4	PERFORM CALIBRATION	146
9.3.5	FULL ADJUSTMENT CALIBRATION	147
9.3.6	ZERO ADJUSTMENT	149
9.3.7	VIEW SENSOR STATUS	151
9.3.8	RESTORE FACTORY CALIBRATION	151
10.	Data Log	153
10.1	Data Log Setup Menu	153
10.1.1	How to Set the Data Log Filename	153
10.2	TRIGGER Menu	155
10.3	Periodic Trigger Options	155
10.3.1	TIME INTERVAL	155
10.3.2	LOG DURATION	156
10.3.3	DATA POINTS	157
10.4	Setting up Manual Data Logging	158
10.5	How to Do Periodic Data Logging	160
10.6	Viewing & Deleting Data Log Files	161
10.6.1	To View Data Log Files on the Instrument	161

10.6.2	To View Data Log files on a PC	162
10.6.3	How to Erase Data Log Files	163
10.7	How to Copy a Data Log file	164
11.	Analysis	167
11.1	Overview	167
11.2	Analysis Application	167
11.3	Setup	167
11.3.1	START/END Values	168
11.3.2	LINEARITY	168
11.3.3	ERROR TYPE	168
11.3.4	TOLERANCE	168
11.4	Analysis Function	168
11.4.1	DATA LOGGING Within Analysis	169
12.	Documenting	171
12.1	Overview	171
12.1.1	How to Start the Documenting Application	171
12.2	Internal Procedures	171
12.2.1	How to Select the INTERNAL PROCEDURES Mode	171
12.2.2	How to Make an Internal Procedure	172
12.2.3	How to Start a Test Procedure	179
12.2.4	How to Delete a Test Procedure	180
12.2.5	Test Procedure Parameters	180
12.3	The Documenting Main Screen	183
12.4	Documenting Settings	185
12.5	How to do a Test Procedure	186
12.6	Post Examination of Test Procedure Results	188
12.7	How to Make an Adjustment on the Device Under Test (DUT)	188
12.8	How to do a Test Procedure Again	189
12.9	How to See Test Results	190
12.10	How to Erase Asset Data	191
12.11	How to Use the Calibration Certificate Wizard	191
12.12	Remote Documenting	192
12.12.1	Setup and Connection.	193
12.12.2	How to use 4sight2 (Remote) Calibration Test Procedures	196
12.13	Linear or Proportional Test Procedure	197
12.14	Switch Test Procedure	200
12.15	How to Do an Adjustment on the Device Under Test (DUT)	205
12.16	How to View Test Results	205
12.17	How to Erase Remote Procedure Files	208
12.18	Uploading Test Results To 4Sight2	208
13.	HART	211
13.1	HART® Application	211
13.1.1	How to Start the HART Application (Method 1)	211
13.1.2	How to Start the HART Application (Method 2)	213
13.1.3	HART Device Electrical Connection	213
13.2	HART Device Configuration	214
13.3	HART Dashboard	217
13.3.1	Unique ID	218

13.3.2	Device Information	219
13.3.3	Measure Variables	220
13.3.4	Signal Condition	220
13.3.5	Sensor Information	221
13.4	HART Service Methods	221
13.4.1	LOOP TEST	222
13.4.2	D/A OUTPUT TRIM	223
13.4.3	PRESSURE ZERO TRIM	226
13.5	HART Error and Message Codes	227
14.	Instrument Calibration	229
14.1	How to show the Instrument Calibration Screen	229
14.1.1	The Instrument Calibration screen options	230
14.2	HOW TO DO CALIBRATION	230
14.2.1	Calibration - Electrical Functions	231
14.2.2	Calibration - Internal Pressure Sensor	234
14.2.3	Calibration – Internal Barometer	237
14.3	INTERNAL PRESSURE SENSOR STATUS	239
14.4	SET CALIBRATION DATE & INTERVAL	240
14.4.1	How to change the Last Calibration Date	241
14.4.2	How to change the Calibration Interval	241
14.4.3	How to change the Calibration Due Date	242
14.5	BACKUP CALIBRATION	242
14.6	RESTORE CALIBRATION	243
14.7	RESTORE FACTORY CALIBRATION	243
14.8	EXTERNAL PRESSURE SENSOR CALIBRATION MENU	243
14.8.1	PERFORM CALIBRATION	244
14.8.2	VIEW EXTERNAL PRESSURE SENSOR STATUS	245
14.8.3	SET CALIBRATION DATE & INTERVAL	245
14.9	EXTERNAL RTD SENSOR CALIBRATION MENU	247
14.9.1	HOW TO DO CALIBRATION	248
14.9.2	SET CALIBRATION DATE & INTERVAL	250
15.	Files System	253
15.1	How to Get to the Files System Menu	253
15.1.1	The Files System Screen Options	253
15.2	Calibration	253
15.3	Data Log	254
15.4	Procedures	254
15.5	Leak Test	255
15.6	Switch Test	255
15.7	Relief Valve	256
15.8	How to View the File System on a PC	256
15.9	Favorites, Error Log and Event Log	257
16.	Status Menu	259
16.1	Status Menu Options	259
16.2	How to Show the Status Menu Screen	259
16.3	SOFTWARE BUILD	259
16.4	CALIBRATION	260
16.5	BATTERY	260

16.6	MEMORY	261
16.7	SENSOR	261
16.8	ERROR LOG	261
16.8.1	How to Export and View Exported Error Log Files	262
16.9	EVENT LOG	262
16.9.1	How to Export and View Exported Event Log Files	262
17.	Favorites Menu	265
17.1	Favorites Menu Options	265
17.1.1	Save Current Calibrator Task	265
17.1.2	Save New Configuration as Favorite	266
17.2	To Load a Favorites Setup	267
17.3	Edit an Existing Favorite File	267
17.4	Delete Favorite Files	268
17.5	Transferring Favorite Files	268
17.6	How to get access to Favorite Files through the File System	268
18.	General Specification	269
18.1	Maximum Leak Rates	269
18.1.1	Pneumatic Version	269
18.1.2	Hydraulic Version	269
18.2	Open Source Software Licenses	269
19.	Manufacturer	271
19.1	Contact details	271
Appendix A.	COMPLIANCE STATEMENTS	i
A.1	FCC (USA)	i
A.1.1	Federal Communication Commission Interference Statement	i
A.1.2	FCC Radiation Exposure Statement	i
A.2	CANADA	i
A.2.1	ISED Canada Statement	i
A.2.2	Radiation Exposure Statement	ii
A.2.3	Déclaration d'exposition aux radiations	ii

1. Overview

The DPI610E type of instrument is a portable pressure calibrator for the calibration of pressure sensors and transmitters and the operation of pressure switches. There are three primary types of this instrument. Models labeled DPI610E are for general (safe area) use. Models labeled DPI610E-IS (Intrinsically Safe) are for use in areas that can have explosive gases. Models labeled DPI610E-A (Aero) are for use in the Aerospace industry in non-IS areas.

This instrument can do pressure measurement and simulation, and has a manual pump to supply pressure. The instrument has a smart and simple user interface for operation by a technician, service or maintenance engineer. The DPI610E has a handle to give a tight hold on the instrument and a shoulder strap for more comfortable use.

The DPI610E is a practical and robust instrument, with reliable and accurate measurements. It is battery-powered and has very reliable pneumatic and hydraulic assemblies for accurate and continuous use, and can be used in harsh conditions. It has data logging functionality, with internal memory for safe file storage.

The instrument has an analysis function for field-error calculations with a PASS/FAIL status, and the ability to make or download procedures on different devices. This gives calibration certification for asset management and maintenance.

The DPI610E instrument can have Bluetooth hardware as an option, to transmit data between other Bluetooth equipped devices. The instrument can use the HART (Highway Addressable Remote Transducer) communication protocol and lets basic HART setup and operation be done on HART supported devices.

The DPI610E-A (Aero) type can do leak tests of aircraft pitot and static systems. It can also do switch tests. For example: cabin pressure switches. This instrument has special safety devices for these tests.

1.1 DPI610E Series

1.1.1 Firmware Versions

The instrument uses application firmware. Refer to “SOFTWARE BUILD” on page 259 for how to find the new versions of the firmware applications. Do checks regularly for updates of this firmware and the End User Software Release Note.

Chapter 1. Overview

1.1.2 DPI610E Variants

Table 1-1: DPI610E Variants

Model Name	Order Code	Case Color	Marked on Unit Front	Pressure Range	Calibrator Type
DPI610E Pneumatic	DPI610E-PC	Blue	DPI610E	0.35 bar - 35 bar (5 - 500 psi) (0.035 MPa - 3.5 MPa)	Pneumatic - Non-IS
DPI610E-IS Pneumatic	DPI610E-SPC	Yellow	DPI610E-IS	0.35 bar - 35 bar (5 - 500 psi) (0.035 MPa - 3.5 MPa)	Pneumatic - Intrinsically Safe
DPI610E Hydraulic	DPI610E-HC	Blue	DPI610E	70 bar - 1000 bar (1000 psi - 15000 psi) (7 MPa - 100 MPa)	Hydraulic - Non-IS
DPI610E-IS Hydraulic	DPI610E-SHC	Yellow	DPI610E-IS	70 bar - 1000 bar (1000 psi - 15000 psi) (7 MPa - 100 MPa)	Hydraulic - Intrinsically Safe
DPI610E Aero Pneumatic	DPI610E-A	Blue	DPI610E	2 bar a (29.6 psi) (0.2 MPa)	Aero - Pneumatic - Non-IS



DPI610E-PC



DPI610E-HC



DPI610E-A



DPI610E-SPC



DPI610E-SHC

Figure 1-1: DPI610E Variants

1.1.3 Equipment in the Package

We supply these items with the DPI610E instrument. Look for these items in the package that holds the instrument.

Note: Hydraulic instruments include a protective cap in the reservoir socket. Keep this cap for future use. It seals the socket when no reservoir is attached.

Table 1-2: Pneumatic Units

Item	Code and Details
DC Power Supply	IO610E-PSU
BSP Swivel Adapter	184-203 †
NPT Swivel Adapter	184-226 †
Blanking Plug	111M7272-1
Let-down Valve (DPI610E-A only)	1 of AN4, AN6, Staubli, Hansen 7/16, Hansen 9/16 as ordered
(IDT) Instrument Dirt Trap - Packed separately	IO620-IDT621-NEW OR IO620-IDT621-IS†
Hose sets: 1 m long †	Safe Area IOHOSE-P1 OR Intrinsically Safe IOHOSE-P1-IS
Electrical Test Lead Set	IO6X-LEAD
2 m USB Cable	IO610E-USB-CABLE
DPI610E Quick Start and Safety Manual	165M0437
Certificates Document Pack	160M2008 IS product only †
Factory Calibration Certificate.	-

† Not applicable for DPI610E-A

Table 1-3: Hydraulic Units

Item	Code and Details
DC Power Supply	IO610E-PSU
BSP Swivel Adapter	184-203
NPT Swivel Adapter	184-226
Blanking Plug	111M7272-1
Hose sets: 1 m long	Safe Area IO620-HOSE-H1 OR Intrinsically Safe IO620-HOSE-H1-IS
Reservoir	Safe Area PV411-115 OR Intrinsically Safe PV411-115-IS - packed separately
250 ml Reservoir Filler Bottle	1S-11-0085

Chapter 1. Overview

Table 1-3: Hydraulic Units

Electrical Test Lead Set	I06X-LEAD
2 m USB Cable	IO610E-USB-CABLE
DPI610E Quick Start and Safety Manual	165M0437
Certificates Document Pack	160M2008 IS product only
Factory Calibration Certificate	-

1.2 Specifications and Accessories for DPI610E

Table 1-4 shows common accessories for the DPI610E series. Refer to our Datasheet for full technical specifications and a full list of accessories for the DPI610E:

www.druck.com

Table 1-4: Common Accessories

Part Code	Description
RTD-INTERFACE-485	RTD Interface only (safe area)
RTD-INTERFACE-IS	RTD IS Interface (IS area)
RTD-PROBE-485	RTD Interface with PT100 Probe (safe area)
RTD-PROBE-IS	RTD Interface with PT100 Probe (IS area)
IO-RTD-M12CON	M12 Field Wireable Connector to fit RTD Interface (IS and safe area)
IO-RTD-M12EXT	RTD M12 male to female extension lead 2 m (6.5 ft) 4-wire
IO-RTD-PRB150	150 mm length 6 mm diameter PT100 steel RTD probe, Class A
PM700E	Remote Pressure Sensor (safe area)
PM700E-IS	Remote Pressure Sensor (IS area)
PM700E-CABLE	Remote Sensor Extension Cable 2.9 m (9.5 ft)
IO620-IDT621-NEW	Bar Dirt and Moisture Trap (safe area)
IO620-IDT621-IS	Bar Dirt and Moisture (IS area)
IO610E-CASE	Carrying Case (suitable for IS and safe area use)

1.3 Use of Manual



INFORMATION This manual has user instructions and safety information for the DPI610E series of instruments. All personnel must be correctly trained and qualified before they use or do maintenance on the instrument. The customer must make sure of this.

Note: Before the use of the equipment always read and obey all warnings and cautions given in the DPI610E Quick Start and Safety Manual.

1.4 Safety



INFORMATION This equipment is safe to use when the procedures in this manual are followed. Operators must read and obey all local Health and Safety regulations and Safe Working Procedures or Practices.

When a procedure is followed:

1. Do not use this instrument for a function that is not in this manual. Incorrect use can reduce safety.
2. Follow all the operation and safety instructions in the Quick Start and Safety Manual.
3. Use approved Technicians and good engineering practice for all procedures in this manual.

1.4.1 General Safety Precautions

- Use only the approved tools, consumable materials and spares, to operate and do maintenance on the instrument.
- Make sure all work areas are clean and clear of unwanted tools, equipment and materials.
- To obey local health and safety and environmental regulations, make sure all unwanted consumable materials are discarded.

1.4.2 Software Configuration and Security

Before use, make sure the related instrument settings are as expected. Other personnel that have access to the instrument, can have made unknown changes. Visually inspect the instrument for this type of change, before measurements are taken and calibrations done with the instrument.

1.4.3 Operation in a Dangerous Area



WARNING Do not use the blue case color instruments in locations that have explosive gas, vapor or dust. There is a risk of an explosion.

Refer to the Quick Start and Safety Manual that comes with the instrument.

1.4.4 General Warnings



Make sure that the instrument is safe to use with the medium. Some liquid and gas mixtures are dangerous. This includes mixtures that result from contamination.

Do not use with a medium that has an oxygen concentration > 21% or other strong oxidizing agents.

This product has materials or fluids that can degrade or combust in an environment that has strong oxidizing agents.

Do not use tools on the instrument that can cause incendive sparks - this can cause an explosion.

It is dangerous to ignore the specified limits (refer to Data sheet) for the DPI610E or to use the instrument when it is not in its usual condition. Use the applicable protection and obey all safety precautions.

1.4.5 Electrical Warning

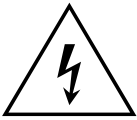

RISK OF ELECTRIC SHOCK To prevent electrical shocks or damage to the instrument, do not connect more than 30 V CAT I between the terminals, or between the terminals and the ground (earth). All connection must agree with the terminal input/output parameters.

External circuits must have applicable insulation to the mains.



WARNING This instrument uses a Lithium-Ion (Li-Ion) battery pack. To prevent an explosion or fire, do not short circuit and do not disassemble. Keep the battery safe from damage.



WARNING To prevent an explosion or fire, only use the Druck specified battery (150M8295-1) and power supply (149M4334-1) rated for this instrument.

To prevent battery leakage/damage or excess heat generation, only use the mains power supply in the ambient temperature range 0 to 40°C (32 to 104°F). The power supply input range is 90 – 264 VAC, 50 to 60 Hz, 300 mA, installation category CAT II.

Note: Long time exposure to temperature extremes can decrease battery life. For maximum life, do not expose the battery to temperatures outside the range -20°C to +40°C for long periods. The recommended storage temperature range is -20°C to 25°C.

Note: Put the power supply in a location that always gives access to the supply disconnection device.

Note: The instrument is applicable for short-term and long-term temporary over-voltage that can occur between the line conductor and earth in electrical installations.

Note: Keep all leads free from contaminants.

1.4.6 Pressure Warnings



INFORMATION The instrument contains an internal over-pressure vent mechanism to protect the internal pressure sensor and pump mechanism from damage.

Note: Maximum Operating Pressure (MWP) is given on the label on the bottom of the instrument. Over pressure must be limited to $1.2 \times \text{MWP}$ (MWP is based on unit pressure range).



WARNING Always use applicable eye protection when work is done with pressure.

To prevent a dangerous release of pressure, make sure that all connected pipes, hoses and other accessories have the correct pressure rating. They must also be safe to use and are correctly attached. Isolate and bleed the system before you disconnect a pressure connection.

It is dangerous to attach an external source of pressure to the instrument. Use only the internal mechanisms to set and control pressure in the pressure station.

1.4.7 Overvoltage Categories

The summary below, of installation and measurement overvoltage categories, uses data from the standard, EC610101. The overvoltage categories show the category levels of overvoltage transients.

Table 1-5: Overvoltage Categories

Category	Description
CAT I	This is the least dangerous overvoltage transient. CAT I equipment cannot be directly connected to the mains power. For example, a process loop powered device.
CAT II	This is for single phase electrical installation. For example, appliances and portable tools.

1.5 Maintenance

Use the procedures in this User Manual for the maintenance of the instrument. For information about maintenance subjects please contact:

www.bakerhughesds.com/druck/global-service-support

This table summarizes manufacturer recommended maintenance tasks for the DPI610E types.

Table 1-6: Maintenance Tasks

Task	Period
Visual Inspection	Before Use
Cleaning	Determined by usage
Calibration	12 months (recommended)

1.5.1 Visual Inspection

Examine the instrument before use. Look for signs of damage: for example, cracks in the case, pressure connector damage or pressure leakage. Do this to make sure the instrument continues to work safely.

1.5.2 How to Clean the Instrument

Use a damp cloth with water and mild detergent to clean the surface of the instrument. Do not put the instrument into water.

Chapter 1. Overview

1.5.3 Calibration

To calibrate the instrument, please contact the Services and Support Locations shown at the back of this guide.

1.6 Service and Repair



WARNING The equipment contains no user serviceable parts. Internal components may be under pressure or present other hazards. Servicing, maintaining, or repairing the equipment may result in damage to property and serious personal injury (including death). Therefore it is paramount that service activities are undertaken only by a Druck authorized service provider.

Repair activities undertaken by unauthorized personnel may invalidate the equipment warranty, safety approvals and design condition. Druck cannot be held liable for any damages (including damage to the equipment), monetary fines, property damage or personal injury (including death) that may occur during or as a result of service maintenance or repair work undertaken by an unauthorized service provider.

Internal components, such as the lithium battery pack, can be under pressure or cause other dangers if used incorrectly.

For more details, please see the Services and Support Locations shown at the back of this guide.

1.7 Spares

For technical support about spare parts, please contact:

drucktechsupport@BakerHughes.com

1.8 Instrument Return

1.8.1 Returned Goods Procedure

If the instrument has to be calibrated or is not serviceable, please send it to the nearest Druck Services and Support Location shown at the back of this guide.

Get a Return Goods Authorization (RGA) from the Service Center. If you are in the USA, get a Return Material Authorization (RMA).

Give the following information on either a RGA or RMA:

- Product code
- Serial number
- Information about the defect/work to be done
- Error code(s) if applicable
- Conditions in which device was used.

1.8.2 How to Discard the Instrument

Do not discard this product as household waste. Use a Recycling Passport for the product. This can be downloaded from our website. See the back of this guide.

Use an approved organization that collects and/or recycles unwanted electrical and electronic equipment.

For more information go to our website for Customer Service Department or go to your local government office:

<https://www.bakerhughes.com/druck>

1.9 Packaging for Storage or Transportation

1.9.1 Environment

Operate, store and transport the equipment in the conditions shown in the table below.

Table 1-7: Conditions for Operation, Storage and Transportation

Condition	DPI610E	Mains Plug 149M43341
Outdoor use	Not for permanent installation outdoors	For indoor use only
IP rating	IP54	IP20
Operating temperature	-10 to 50°C	-10 to 50°C
Storage and shipping temperature	-20 to 70°C	-20 to 70°C
Altitude	-300 to 2000 m	-300 to 2000 m
Operating humidity	0 to 95% relative humidity (RH) non-condensing	0 to 95% relative humidity (RH) non-condensing
Pollution degree	1	1

1.10 How to Prepare the Instrument



INFORMATION When you receive the instrument, make sure that the package has the items listed in Section 1.1.3, “Equipment in the Package,” on page 3. Keep the package and its packaging for future use.

1.10.1 Initial Checks

- Visually examine the instrument (for cracks or defects).
- Do not use equipment that is known to have damage or is defective.
- Make sure the battery is charged (see Section 1.11).

1.11 Battery and Charging

The instrument has a rechargeable Li-ion battery. To charge the battery, push the power supply into the DC charging port that is under the protection flap at the top of the instrument.

The instrument can also be charged from any vehicle with a standard 12 V accessory socket with an IO610E-CAR CHARGER (optional accessory).

The instrument can be charged while energized (Power On) and also when de-energized (Power Off). Battery charge time is approximately two hours from empty to fully charged.

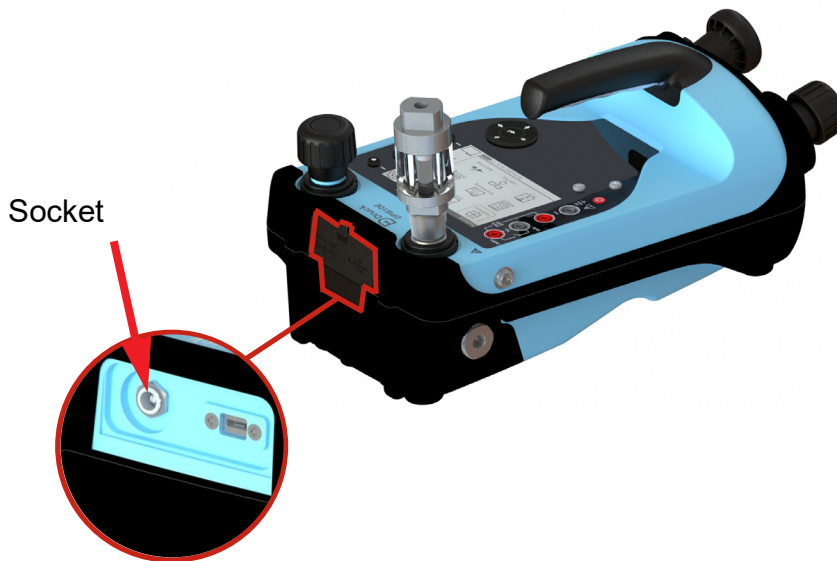

Figure 1-2: Battery Charging Socket

1.11.1 Battery Status Indicator



Figure 1-3: Battery Status Indicator

The battery status indicator (on the right-hand side of the instrument) can show the battery level when the instrument is de-energized. Push the circular button on the right of the display to temporarily show the charge: the display will automatically stop after a few seconds. Each LED represents approximately 25% battery capacity.

1.12 Power ON and OFF

1.12.1 Power ON

To energize the instrument (Power On), hold down the power button  for approximately 1 second, until the User Interface shows the Druck Logo.

1.12.2 Power OFF

To de-energize the instrument (Power Off), hold down the power button  for approximately 2 seconds until the User Interface shows the closing screen.

1.12.3 Auto Power Down

The instrument has an Auto Power Down function that can be selected or canceled when wanted. See General Settings Section 4 on page 37. On the instrument the function is in the **General Settings**  screen on the Dashboard.

1.13 Parts

1.13.1 Pneumatic Instruments

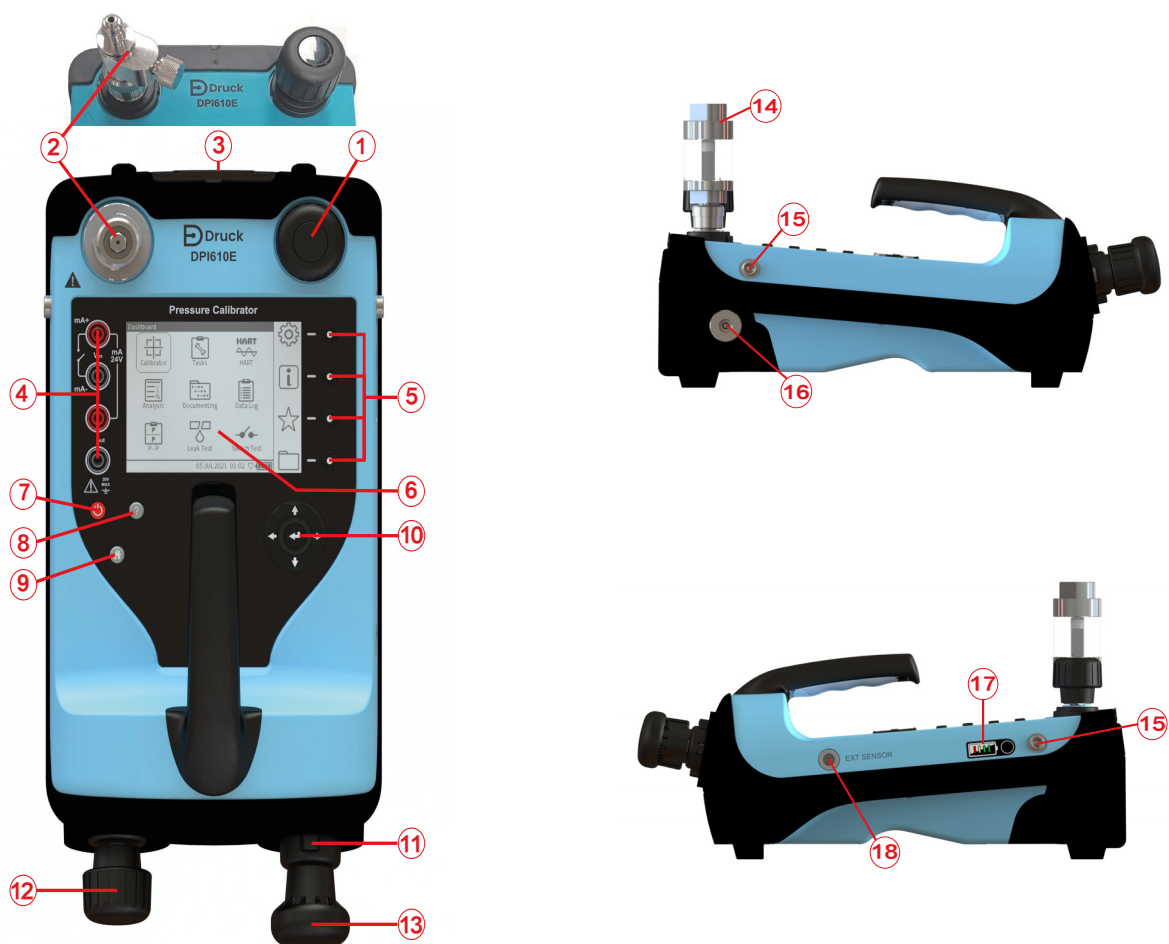

Number	Item	Number	Item
1	Pressure Release Valve	10	Navigation Pad
2	Test Port (including Swivel Connector) DPI610E-A: Let-down Valve	11	Pressure/Vacuum Selector
3	Auxiliary Ports (DC power supply port Battery Charging, USB micro port)	12	Volume Adjuster (Fine control of pressure)
4	Electrical 4 mm sockets	13	Pressure/Vacuum Hand Pump
5	Softkeys	14	Instrument Dirt (& Moisture) Trap (IDT)
6	User Interface	15	Clip Fastener for Carrying Strap
7	Power ON/OFF Button	16	Barometer Port
8	Help Button	17	Battery Level Indicator
9	Home Button	18	External Sensor Port

Chapter 1. Overview

1.13.2 Hydraulic Instruments

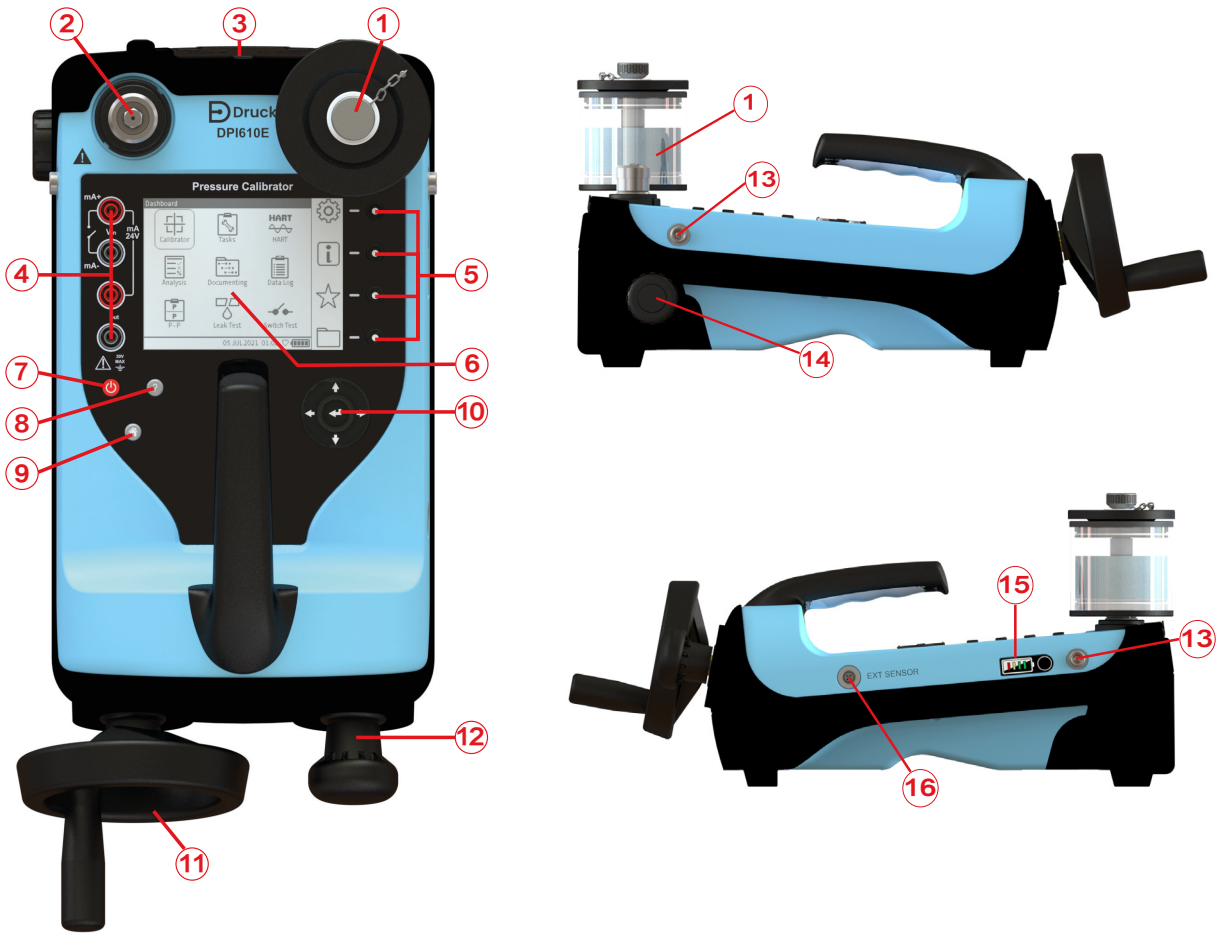

Number	Item	Number	Item
1	Hydraulic Reservoir	9	Home Button
2	Test Port (including swivel connector)	10	Navigation Pad
3	Auxiliary Ports (DC power supply port Battery Charging, USB micro port)	11	Volume Adjuster Wheel (Fine control of pressure)
4	Electrical 4 mm Sockets	12	Priming Pump
5	Softkeys	13	Clip Fastener for Carrying Strap
6	User Interface	14	Pressure Release Valve
7	Power ON/OFF Button	15	Battery Level Indicator
8	Help Button	16	External Sensor Port

1.13.3 Test Port

The Test Port is at the top left corner of the instrument. Pressure can be supplied to pressure devices that are connected, either directly or by the use of compatible hose fittings. The Test Port

on a DPI610E-A type connects to a pitot or static system through a manual Let-down Valve provided as an accessory.

1.13.4 Reservoir (Hydraulic Version)

Put the correct hydraulic fluid into the Reservoir before use. Use the recommended fluid ISO viscosity grade ≤ 22 , such as demineralized water or mineral oil.

1.13.5 Pressure Release Valve

The Pressure Release valve is on the top right of the instrument for pneumatic variants. It is on the left-hand side for hydraulic variants. To release all pressure in the instrument, slowly turn the pressure release valve counterclockwise to open the valve. Make sure the system is sealed before pressure generation: fully close the Pressure Release Valve in the clockwise direction.

1.13.6 Electrical Connections

Four electrical 4 mm sockets are on the left side of the instrument. These have labels for different electrical measurement or source functions.

1.13.7 Let-down Valve (DPI610E-A)

This valve attaches to the Test Port and releases air pressure to let the instrument fully go to ground level pressure. A rapid drop in pressure can cause damage to the instrument. Open the Let-down valve slowly and monitor the pressure reading until the necessary pressure is reached.

1.13.8 Pump (Pneumatic Version)

When the Pressure/Volume Selector is in the (+) orientation the hand pump supplies pressure as you operate the pump. When the selector is in the (-) orientation the pump makes a vacuum as you operate the pump. To prevent damage to the device, fully vent the system before selecting either vacuum or pressure.

1.13.9 Priming Pump (Hydraulic Version)

Use the Priming Pump to move hydraulic fluid from the reservoir and force air, gas or vapor present, out of the system.

1.13.10 Volume Adjuster (Pneumatic Version)

For fine adjustment, use the Volume Adjuster to control the pressure.

1.13.11 Volume Adjuster Wheel (Hydraulic Version only)

Use the Volume Adjuster Wheel to adjust the pressure in the range of 20 - 1000 bar. To increase the pressure, turn the wheel clockwise. To decrease the pressure, turn the wheel counterclockwise.

1.13.12 Pressure/Vacuum Selector (Pneumatic Version only)

The selector can be set to supply a pressure or a vacuum. To prevent damage to the instrument the system must be fully vented before the selection of either vacuum or pressure.

1.13.13 Auxiliary Ports

The auxiliary ports are at the top of the instrument and under the rubber flap. These ports are for a DC power supply and for a Micro USB.

1.13.14 External Sensor Port

On the right side of the instrument is the RS485 communications port for the connection of external remote sensors, such as the PM700E pressure sensor and the RTD-Interface and RTD-probe.

Chapter 1. Overview

1.13.15 Barometric Port (Pneumatic Version only)

The left side has a Barometer Port that has a static pressure inlet for the internal barometric pressure sensor.

1.14 User Interface



Figure 1-4: Instrument User Interface (non-IS and IS) - not DPI610E-A

You can operate the User Interface (Figure 1-4) by the use of its Touchscreen, the Navigation Pad, buttons and the Softkeys.

1.14.1 Buttons and Softkeys

1.14.1.1 Power Button

Use the Power button  to supply power to the instrument. See Section 1.12, “Power ON and OFF,” on page 10.

1.14.1.2 Help Button

The Help button  gives information for how to use the instrument. It is context-sensitive - the information shown will relate to a screen or task in use at that moment in time. The Help button also gives a web link and QR code. These give access to the full user manual online through a smart device or PC.

1.14.1.3 Home Button

The Home button  gives a quick method for quick access to the Dashboard home screen from all locations in the user menu.

1.14.1.4 Enter Button

An Enter button  is in the middle of the Navigation Pad.

1.14.1.5 Navigation Pad



The Navigation Pad has Up, Down, Left, Right and Enter buttons for quick and easy movement through the user interface.

1.14.1.6 Softkeys

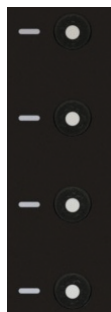

There are four Softkeys to the right side of the LCD display. These Softkeys are context-sensitive: the menu or task in use controls the function these keys select. Each Softkey has a related on-screen icon that visually shows the purpose of that specific button (as shown in Figure 1-4.) The icons on the User Interface also operate as Touchscreen buttons for the same operation as the related Softkey.

1.15 First Use

Examine the default settings for the instrument, to make sure they are correct before the first use of the instrument. Refer to Section 4 on page 37 for how to set instrument default values. For example, it can be necessary to change the language for the User Interface or the time and date.

1.16 Dashboard

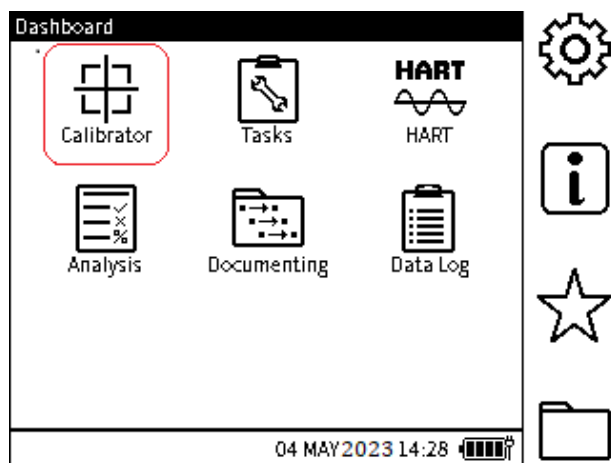

Figure 1-5: Instrument Dashboard (non-IS and IS)

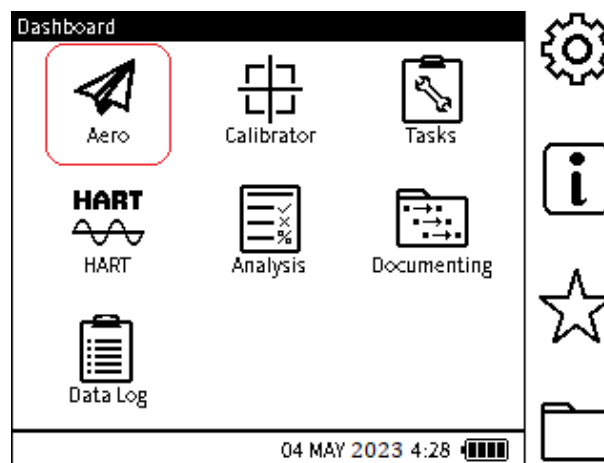

Figure 1-6: Instrument Dashboard (DPI610E-A only)





When the instrument is energized (powered up), the User Interface shows the Dashboard. The Dashboard is the home screen through which all functions, tasks and settings are available. The Dashboard has icons that relate to different applications. The **Calibrator**, **Tasks**, **HART**, **Analysis**, **Documenting**, and **Data Log** icons are set and thus always available.

Note: Shortcut icons can be added to the User Interface for applications, (See Chapter 3 on page 33).

Chapter 1. Overview

1.16.1 Dashboard Softkeys

The Dashboard Softkey icons are on the right of the User Interface screen. They are:

-  General Settings
-  Status
-  Favorites
-  File System

To operate an icon, tap the screen where the icon is or push the Softkey on the right of the icon.

Note: The icons on the sidebar are always available in the Dashboard.



INFORMATION Be careful to not accidentally touch the User Interface when using the instrument. This can make the system do unwanted operations. This can happen, for example, when cables are pushed into the sockets in the face of the instrument or when cables touch the screen.

1.16.2 Dashboard Navigation

To get access to an application, select the related icon on the Dashboard. The Navigation Pad buttons can also be used to move between icons on the dashboard, as described in Section 1.14.1.5.

To get access to the icons on the side bar, select the icon on the display, or push the related Softkey for the icon.

Note: To go back to the Dashboard, select the **Home** button .

1.16.3 Set Date, Time and Language

1.16.3.1 Date and Time

To open to the Date/Time menu screen (Figure 1-7), select:

Dashboard >  General Settings > DATE/TIME

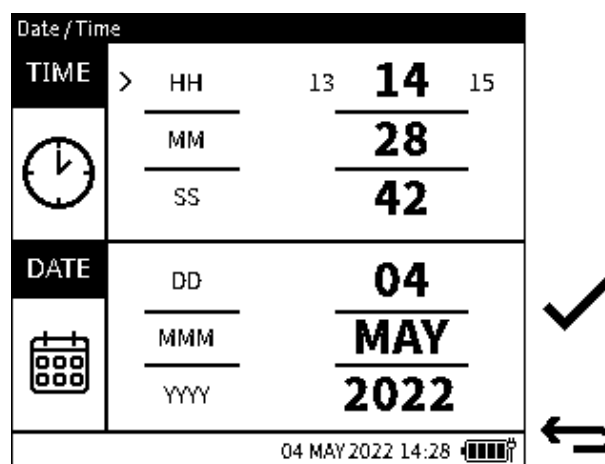

Figure 1-7: Date/Time Menu Screen

On the Navigation Pad, use the **UP/DOWN** buttons to select the time and date parameters to be changed. Use the **LEFT/RIGHT** buttons to increase or decrease the values. If using the Touchscreen, tap the wanted time or date parameter to be changed. Tap on the right side of the set value (bold font) to increase or on the left side to decrease the value.

When all parameters are selected, push the **Tick** ✓ Softkey to accept the **Date/Time** changes. If changes are not to be saved and to go back to the previous screen, tap the **Back** ↶ button.

1.16.3.2 Language

To open the **Language** menu (Figure 1-8), select:

Dashboard >  **General Settings** > **Language**



Figure 1-8: Language Menu Screen

Use the Navigation Pad buttons to select the wanted language. If using the Touchscreen, tap on the necessary language option. Push the **Tick** ✓ Softkey to accept the changes. If changes are not to be saved or to go back to the previous screen, tap the **Back** ↶ button.

2. Pump Operations

The instructions in this chapter are for the use of the DPI610E and DPI610E-IS. Refer to Chapter 8, “The DPI610E-A Instrument,” on page 105 for the instructions that relate to the use of the Aero version of this instrument.

2.1 Pneumatic System

2.1.1 Using the Blanking Plug



A Blanking Plug seals the Test Port. Attach the Blanking Plug when the Test Port is not in use. This keeps the port clear of unwanted material.

To attach the Blanking Plug to the Test Port, put the plug into the swivel connector and hold in position. Turn the swivel connector fully counterclockwise until it is hand-tight.

To release the plug, hold the plug in position and turn the swivel connector clockwise until the plug can be removed.

2.1.2 Flexible Hose

The DPI610E includes a flexible hose. Use this hose to connect the instrument to other equipment. Before use, always visually examine the hose for faults, such as splits or cuts in the hose. Always make sure the instrument is safe for use.



INFORMATION Movement or compression of connecting hoses can affect measured pressure readings. Keep hoses stable while taking pressure measurements.

2.1.3 How to Vent to Atmosphere



CAUTION A rapid drop in pressure can cause damage to the instrument. Open the pressure release valve slowly and stop when the display shows the necessary pressure.



To vent the system to atmospheric pressure, slowly turn the pressure release valve fully counterclockwise until the sensor reading goes to zero (gauge sensor) or 1 bar (absolute sensor).

Chapter 2. Pump Operations

2.1.4 To Attach the Instrument Dirt Trap to the Test Port



INFORMATION Always use a Dirt Trap.



CAUTION To avoid damage to the Dirt Trap, hold it tightly and turn it into the Test Port.

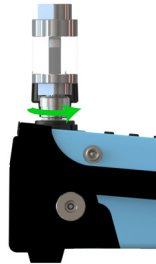

To attach the Instrument Dirt Trap (IDT) to the Test Port, first remove the Blanking Plug if it is in the test socket: turn the swivel connector clockwise to release the plug. Put the trap into the socket and turn the swivel connector fully counterclockwise until it is hand-tight.

2.1.5 To Attach the Device Under Test



CAUTION To prevent damage to the device under test, hold it tightly and turn it into the Test Port/dirt trap.



To attach the device under test to the Test Port or dirt trap, put the trap into the thread of the swivel connector, then turn the swivel connector fully counterclockwise until it is hand-tight.

Note: Make sure that the device under test has a male G $\frac{3}{8}$ Quickfit adapter thread or use a suitable adapter rated to 35 bar. If in doubt, please contact our Service Support - see the back of this manual.

2.1.6 To Remove the Device Under Test



CAUTION A rapid drop in pressure can cause damage to the instrument. Open the pressure release valve slowly and stop when the screen shows the necessary pressure.

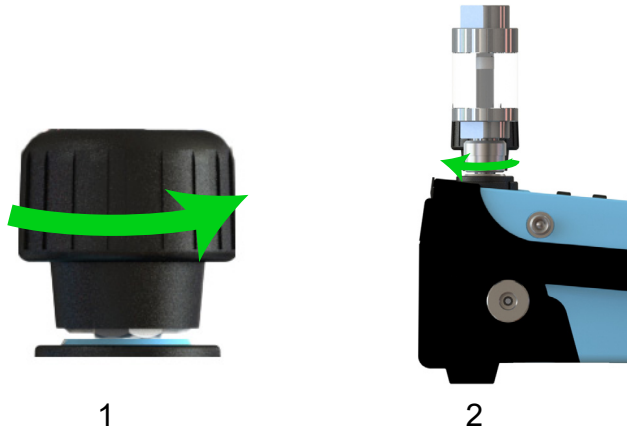

1. Slowly open the Pressure Release Valve fully counterclockwise to release all of the pressure in the instrument.
2. To remove the device under test, hold it tightly and turn the swivel connector fully clockwise. If the instrument will not be immediately used, attach the Blanking Plug to seal and protect the socket. See “Using the Blanking Plug” on page 19.

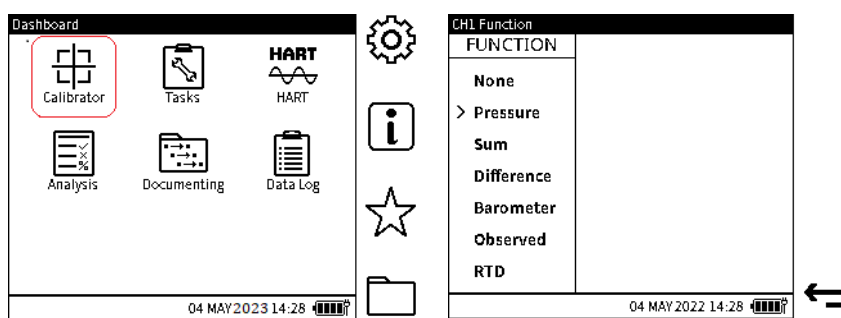

2.1.7 To Prepare the Instrument for Pressure/Vacuum Operation

1. Make sure the instrument is safe to use - refer to the instructions on page 19.
2. To energize (power ON) the instrument, push down the power button  for 1 second until the display shows the Druck start screen.



3. Select the necessary pressure function from the Channel Function screen. From the dashboard select:

CALIBRATOR >  ^{CH1} or  ^{CH2} > **FUNCTION** > **Pressure** > **INT** > **Normal**

Select the Tick  Softkey and tap the **Back**  icon.

Chapter 2. Pump Operations

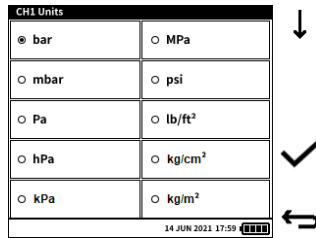

4. Select different units of measurement if necessary. From the dashboard select:

CALIBRATOR > **CH1** or **CH2** > **UNITS**

then either tap the wanted unit on the screen or use the Navigation Pad arrow keys to select the unit.

Select the **Tick** Softkey and tap the **Back** icon.



5. To attach the device under test to the Test Port or Dirt Trap, hold the device in the socket, then turn the swivel connector at the base of the connector fully counterclockwise until it is hand-tight. Make sure that the device under test has a male G 3/8 Quickfit adapter thread or use a suitable adapter rated to 35 bar. If in doubt, please contact our Service and Support - see back page.



CAUTION To avoid damage to the device under test, hold it firmly while screwing it into the Test Port/dirt trap.

2.1.8 To Supply Medium Pressure or Vacuum

Note: This procedure is for general use. It is not for low pressure (350 mbarg) or high vacuum (-950 mbarg).



1. Turn the Pressure Release Valve firmly fully clockwise to seal the system.



CAUTION Do not put the instrument into the pressure medium. If fluid goes into the electrical connection panel, remove the fluid and let the instrument fully dry before use.

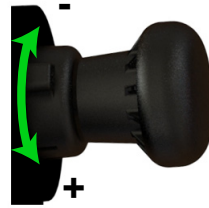

- Turn the Pressure/Vacuum Selector to either the pressure mode (+) or vacuum mode (-).

Note: Adjust the selector clockwise for vacuum mode. Adjust the selector counterclockwise for pressure mode.



CAUTION To prevent unwanted instrument movement, use the slip prevention feet or put the instrument against a flat surface.

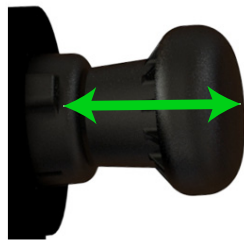

3

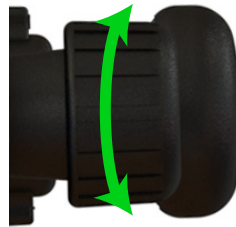

4



5

- Use the pump to make the wanted pressure or vacuum. Push and pull the pump knob fully in and out for best results.
- Turn the Volume Adjuster to make fine adjustments to the pressure/vacuum.
- To decrease pressure or increase from vacuum, open and close the Pressure Release Valve slowly until you reach the necessary pressure.



CAUTION A fast change in pressure can cause damage to the instrument. Open the Pressure Release Valve slowly and stop when the screen shows the necessary pressure.

2.1.8.1 To Supply Low Pressure (350 mbarg Full Scale)

- Correctly connect the device under test to the Test Port. Make sure that the DPI610E release valve is also fully open (turn counterclockwise).
- Move the Pressure/Vacuum Selector to the '+' position to select the pressure mode.
- Turn the Volume Adjuster counterclockwise until it is approximately half way out (around 25 rotations from fully open or shut).
- Seal the system by closing the Pressure Release Valve (turn clockwise) to hand-tight.
- Make sure that the device screen shows the internal pressure (or external pressure if an external sensor is fitted).
- Push the pump knob slowly and carefully and look at the screen for the increase of pressure. Stop when the display shows the necessary pressure. It is good practice to pump with smaller strokes with low pressures such as 350 mbar and 1 bar, or use the Volume Adjuster for finer control on pressure.

If the pressure is below the necessary value, go back to step 5.

Chapter 2. Pump Operations

If the pressure is too high or if the display shows >>>>>> (the pressure is above the internal sensor full-scale limit), slowly turn the Volume Adjuster counterclockwise to decrease the pressure to the necessary value.

2.1.8.2 To Supply a High Vacuum (-950 mbarg)

1. Turn the Pressure/Vacuum Selector to the vacuum '-' position. Note that as the vacuum increases, it is only the last part of the pump travel (i.e. fully pulled-out) that increases the vacuum. This is equivalent to pumping positive pressure, where it is only the last part of the inward travel that pushes air past the non-return valve as pressure rises. So, for effective use, pull the pump fully out (until the end stop is felt) to effectively generate vacuum. It is better to pull the pump knob out quite quickly (until end stop is hit), because this keeps the non-return valve fully open.
2. Turn the Volume Adjuster clockwise until it stops and then rotate counterclockwise for about 5 to 10 rotations.
3. Getting to -950 mbar needs the removal of 95% of the air from the system, needing approximately 15-20 (fast) strokes.
4. If you cannot reach -950 mbar using the pump then stop the use of the pump and instead use the Volume Adjuster.
5. Rotate the Volume Adjuster counterclockwise to increase the vacuum and then to reduce/adjust the vacuum pressure as necessary. If you reach -950 mbar but then the vacuum starts to decrease, this is because there is a leak in the system. Make sure that the release valve is tightly shut and that the IDT (Instrument Dirt Trap) top/bottom seals do not leak.

2.2 Hydraulic System

2.2.1 How to Fill the Reservoir

Make sure the instrument is not pressurized: refer to Section 2.2.2 for how to release pressure. The instrument is supplied with a 100 cc (3 oz) reservoir. The reservoir can be filled attached or detached from the instrument. When the reservoir is removed, seal the socket on the DPI610E with the protective cap supplied with the instrument. This cap keeps the port free of unwanted material. Make sure that the pressure medium is compatible with your test device.

Note: We recommend demineralized water or mineral oil as the pressure medium.



CAUTION Do not let the instrument go fully into the pressure medium. If fluid goes into the electrical connection panel, let the instrument fully dry before use.

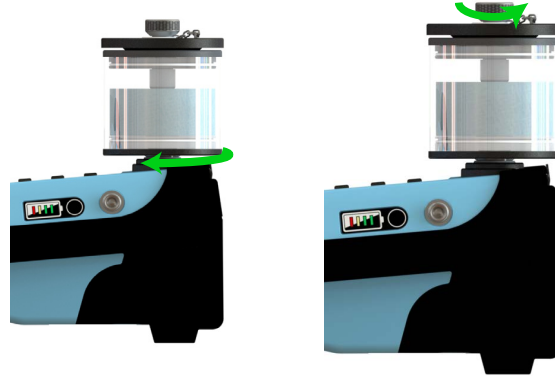

1

2

1. Turn the reservoir clockwise into the reservoir port until it is hand-tight.
2. Turn the reservoir locknut counterclockwise and remove the reservoir cover.



INFORMATION The pressure medium level must stay above the horizontal pin in the reservoir at all times when the instrument is in use. The volume of pressure medium in the reservoir must not be more than 75% when the instrument is in use. To avoid contamination, use only one type of pressure media in the instrument.

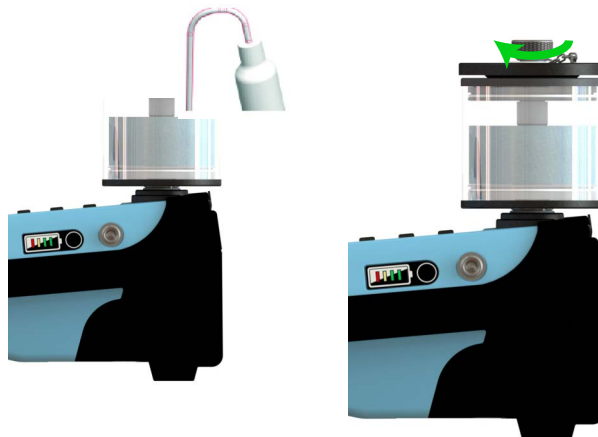

3

4

3. Use the squeeze bottle to fill the reservoir with the pressure medium to approximately 75% capacity of the reservoir.
4. Push the reservoir cover into position and turn the locknut clockwise (finger tight) until the reservoir cover seals the reservoir. Then rotate back a quarter turn (counterclockwise).

Chapter 2. Pump Operations

2.2.2 How to Prime the Instrument



CAUTION Use the Blanking Plug to seal the Test Port before using the pump. Priming the instrument when the Test Port is not sealed can cause the pressure medium to spray from the Test Port into the electrical ports.



INFORMATION A Blanking Plug is supplied with the instrument.



1. Make sure the Blanking Plug seals the Test Port. To attach the Blanking Plug, put the plug into the thread of the swivel connector, hold in position and then turn the swivel connector fully counterclockwise until it is hand-tight.
2. To energize (Power On) the instrument, push down the power button  for 2 seconds until the Druck splash screen appears.

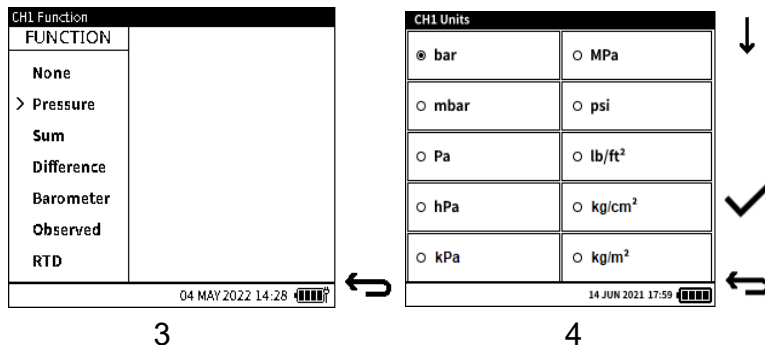

3. Select the wanted pressure function from the Channel Function screen. From the Dashboard select:

CALIBRATOR >  ^{CH1} or  ^{CH2} > **FUNCTION** > **Pressure** > **INT** > **Normal**

Push the **Tick**  Softkey and push the **Back**  icon to show the previous screen.

4. Select the necessary units.

From the Dashboard select:

CALIBRATOR >  ^{CH1} or  ^{CH2} > **UNITS**

Either tap the screen or use the Navigation Pad arrow keys to select the wanted unit.

Push the **Tick**  Softkey and push the **Back**  button to show the previous screen.

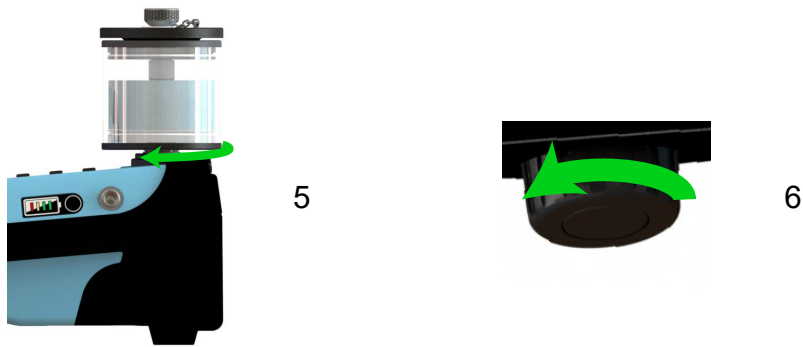

5. Attach the reservoir to the Reservoir Port and fill to the necessary level (approximately 75%). See Section 2.2.1.
6. Make sure that the Pressure Release Valve is at its fully open position by turning counterclockwise.

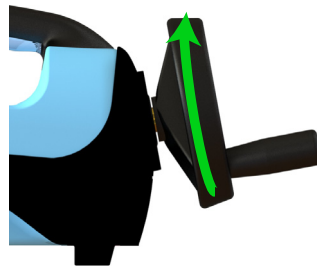

7. Turn the Volume Adjuster Wheel clockwise until it stops: this can be up to 30 turns. This is the zero point.

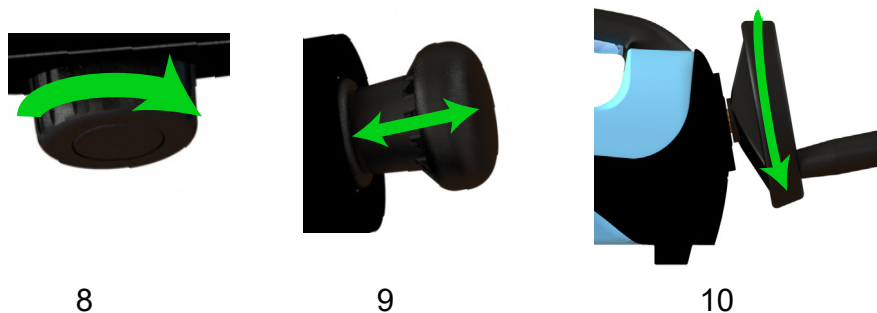

8. Fully close the Pressure Release Valve by turning clockwise.
9. Slowly operate the Priming Pump until the pressure reading is 10 - 15 bar.
10. Pull the Priming Pump backwards until it stops. Start turning the Volume Adjuster counterclockwise. While turning the Volume Adjuster, push the Priming Pump slowly and simultaneously inward until the Volume Adjuster stops (a minimum of 29 turns can be

Chapter 2. Pump Operations

necessary). You are increasing the volume and using the pump to fill the volume. The pressure reading may decrease or it may be between 5 to 15 bar.



11. Slowly operate the Priming Pump until the pressure reading is 10 - 15 bar.
12. Turn the Pressure Release Valve a quarter of a turn counterclockwise to release the pressure. The pressure reading can be approximately 1 bara if using an instrument with an absolute sensor or approximately 0 barg if using an instrument with a gauge sensor.
13. Slowly operate the pump until no air bubbles come out of the hole in the reservoir center tube.
Note: It can take 10-15 full moves of the pump handle to remove trapped air from the system.

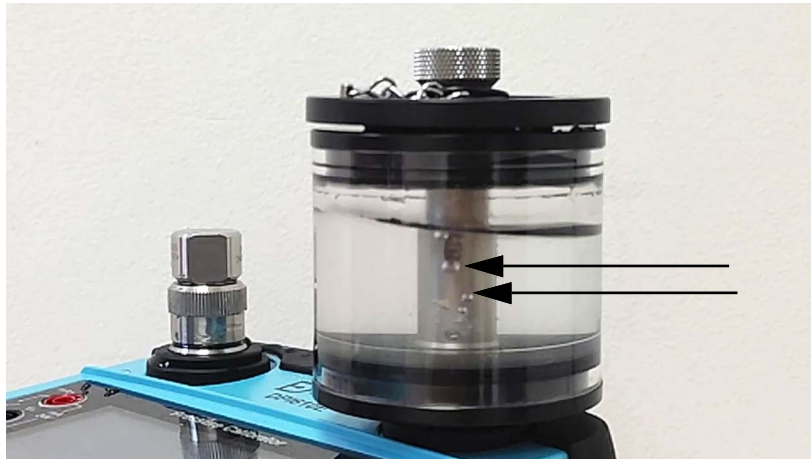

CAUTION When air bubbles do not come out of the hole in the reservoir center tube, stop operating the pump.

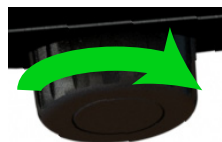

14. Remove the Blanking Plug from the Test Port.



CAUTION Do not remove the Blanking Plug when the instrument is under pressure. Turn the Pressure Release Valve fully counterclockwise until the pressure shown is zero (gauge sensor) or atmospheric pressure (absolute sensor).

15. Turn the Pressure Release Valve fully clockwise, hand-tight.



CAUTION Do not operate the Priming Pump. Only use the Volume Adjuster wheel.

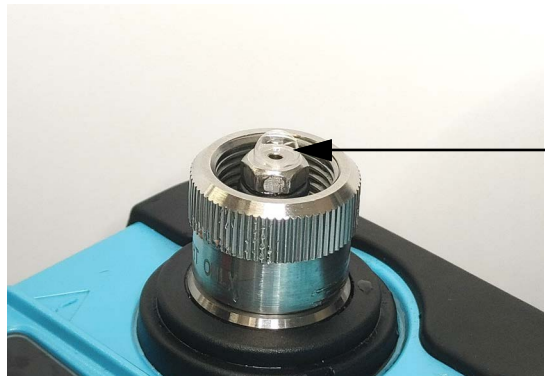
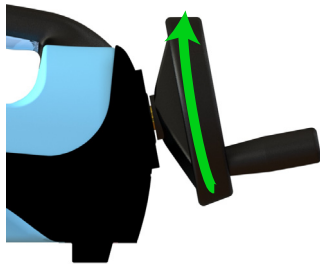

16. Slowly turn the Volume Adjuster Wheel 2-5 turns clockwise to remove all trapped air. If mineral oil is used as the pressure medium, operate the Volume Adjuster carefully to prevent fast ejection of the oil.

Note: Air bubbles can possibly be at the tip of the Test Port. If you notice more bubbles coming out even after 5 turns of the Volume Adjuster or no water coming out at all then restart the priming sequence from the beginning.

17. This step is only when using a hose connected to the Test Port and when removing air from the hose when the test device is to be connected through a hose. If you are to connect a test device directly to the instrument, go to Step 18.
- Close the swivel end of the hose with a blanking plug and then connect the other end of the hose to the Test Port. Make sure the hose is held vertically or the far end of the hose is positioned higher than the Test Port level (this helps to push trapped air to the far end of the hose).
 - Slowly operate the pump until the pressure reading is 10-15 bar.
 - Turn the Pressure Release Valve a quarter of a turn counterclockwise to release the pressure. The pressure reading can be approximately 1 bara if using an instrument with an absolute sensor or approximately 0 barg if using an instrument with a gauge sensor.
 - Turn the Pressure Release Valve fully clockwise, hand-tight.
 - Hold the hose vertically and then remove the blanking plug from the far end of the hose.
 - After removing the blanking plug from the hose end, hold the hose end vertically and then operate the Volume Adjuster slowly 10 - 20 turns clockwise to remove all trapped air in the hose. If the fluid is not coming out of the hose even after 20 rotations then the system is not primed properly. To fill the system again, first bring the Volume Adjuster fully back by rotating counterclockwise until it stops. Rotate the Volume Adjuster clockwise 5 turns. Now use the priming pump gently (very slowly) otherwise fluid will eject at speed from the hose end. We advise that you hold the hose end in a suitable

Chapter 2. Pump Operations

container or cloth and then use the priming pump gently. Stop using the priming pump when you see the fluid leaving the end of the hose.

As an alternative to step f, after removing the blanking plug from the hose end, dip the hose end into a suitable container which is filled with the same fluid. Make sure the Volume Adjuster is fully retracted counterclockwise then rotate the Volume Adjuster clockwise approximately 5 rotations. Then use the Priming Pump gently to move the fluid into the container to push out air bubbles from the hose. Stop when you see no more air bubbles.

Note: If mineral oil is used as the pressure medium, make sure to operate the Volume Adjuster or priming pump carefully to prevent fast ejection of the oil. Collect the oil in a suitable container. Watch the fluid level in the reservoir, if you move or pump more fluid into the container then the fluid level in the reservoir may reduce below the minimum level and it may need refilling.



CAUTION Re-use or dispose of the fluid collected in the container in accordance with the local regulations.

- g. To attach a test device to the hose go to Step 18.



CAUTION Do not let movement of the hose turn the Test Port or the adapter on the Test Port, as this can cause internal damage to the instrument.

18. Hold the test device in position into the thread of the swivel connector on Test Port or far end of the hose, then turn the swivel connector fully counterclockwise until it is hand-tight.

Note: When necessary, use adapters supplied with the instrument or an AMC adapter(s) and the related seal(s).

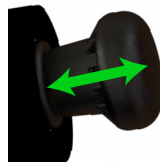

19. After connecting the device to be tested, rotate the Volume Adjuster counterclockwise about half the number turns if done in the first part of step 17f and at the same time slowly push the Priming Pump to keep the fluid pressure between 10-15 bar, this is applicable only if the user used the step 17f to connect the device. Otherwise, use the priming pump to keep the fluid pressure between 10-15 bar.
20. Use the Priming Pump to prime the system to a maximum fluid pressure of 10-25 bar. Now the system is ready to make the necessary pressure - see the next section.

2.2.3 How to Adjust Pressure



INFORMATION Always prime the instrument before using the Volume Adjuster. Know what the instrument pressure range is before pressure is supplied. This range is given on the label on the bottom of the instrument.

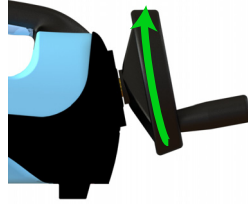

After the instrument is primed (see Section 2.2.2), turn the Volume Adjuster Wheel clockwise slowly (to prevent raising temperature from friction) until the wanted pressure is made. If the wanted pressure is not added or is not stable, release the pressure in the instrument and restart the priming sequence.

2.2.4 How to Release Pressure

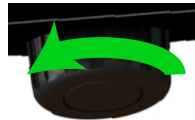

To release pressure, turn the Pressure Release Valve counterclockwise.

2.2.5 How to Achieve 400 bar

If you need pressures above 400 bar, use the pump to prime to approximately 25 to 30 bar. Use a hydraulic hose of no more than 1 m length to connect to the device under test.

Try to rest the rear feet of the instrument against the edge of your table to prevent the instrument from slipping as you use the pump.

Note: Do not use long (or larger-bore) hoses because this can stop the production of the necessary pressure by the pump due to more fluid volume in the system.

2.2.6 To Replace the Fluid in the Hydraulic System

The hydraulic system can either use demineralized water or hydraulic fluid. The following instructions show how to remove old fluid and replace with new fluid of the same type.

Wear personal protection equipment for this procedure. For example, eye protection glasses.

1. Remove the old fluid from the Reservoir (if necessary clean the reservoir) and then fill the Reservoir with fresh fluid (to 75% reservoir capacity). Obey your company's procedures for how to discard the old fluid.
2. Attach the Reservoir to the DPI610E Reservoir Port.
3. Close the Pressure Release Valve (hand-tight).
4. Remove the DUT (or Blanking Plug if attached) and then attach the supplied hose (or compatible hose) to the Test Port and dip the open end of the hose into an empty container.
5. Turn the Volume adjustment wheel counterclockwise until it stops.
6. Move the Pump handle seven strokes to move hydraulic fluid into the container.
7. Turn the Volume Adjustment Wheel clockwise until it stops.
8. Move the pump handle seven strokes again. This will flush out old fluid and replace it with new fluid.

Chapter 2. Pump Operations

9. Remove the hose from the Test Port and then make sure the fluid drains into the container.
10. Dispose of the old fluid collected in the container in accordance with the local regulations.
11. Use the Blanking Plug to seal the Test Port.
12. Make sure the Pressure Release Valve is closed (hand-tight) then energize (Power On) the DPI610E.
13. Operate the pump until the pressure reading is at 20 bar.
14. Open the Pressure Release Valve.

3. Basic Tasks

3.1 Tasks

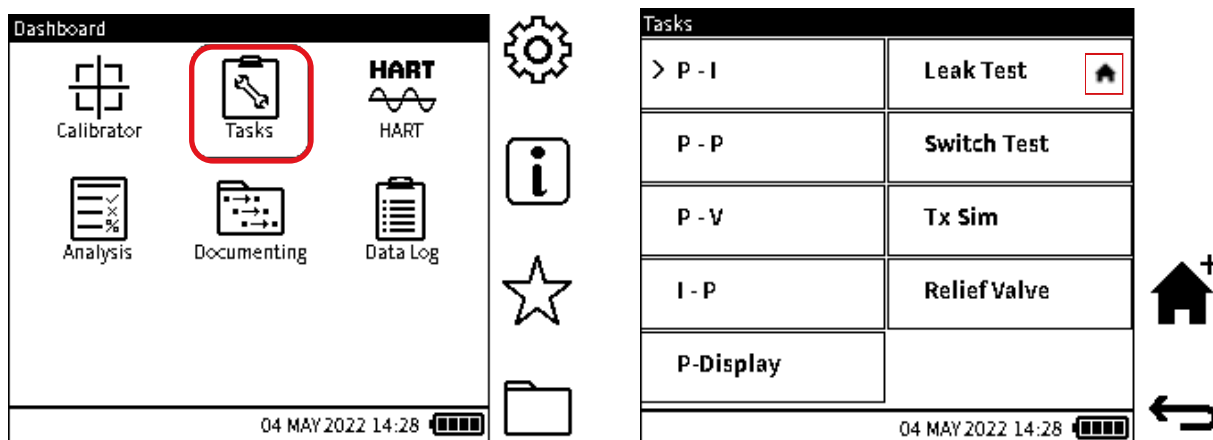

Use the Dashboard to get access to the **Tasks** application. The **Tasks** menu has a list of tests that automatically configure the instrument when selected.

Select the **Tasks** icon on the Dashboard to show a list of available tasks. Tap on the task to select it.

Note: The DPI610E-A has the added icon  on the Dashboard.

Any **Task** option added to the Dashboard screen will have a mini **Home** icon next to the option text, as shown in the second screen. The Dashboard will also have an icon for this task added to it.

The **Tasks** screen has these options:

3.1.1 P - I (Pressure to Current measure)

This sets channel **CH1** to show measured pressure from either the internal (**INT**) or external (**EXT**) sensors. If external pressure function is sensed on **CH1**, it will keep this function. If any other function other than external pressure is sensed, **CH1** will default to show the measured internal pressure.

Channel **CH2** is set to show measured Current.

This task is typically for the calibration of Current Output Pressure transmitters.

3.1.2 P - P (Pressure to Pressure)

This sets **CH1** to show internal (**INT**) pressure measurement and **CH2** to external (**EXT**) pressure measurement.

3.1.3 P - V (Pressure to Voltage)

This sets **CH1** to show measured pressure, which can be internal (**INT**) or external (**EXT**). If external pressure function is sensed on **CH1**, it will keep this function. If any other function other than external pressure is sensed, **CH1** will default to show the measured internal pressure.

CH2 is set to show the measured Voltage.

This task is typically for the calibration of Voltage Output pressure transmitters.

Chapter 3. Basic Tasks

3.1.4 I - P (Current to Pressure)

This sets **CH1** to show measured pressure, which can be internal (**INT**) or external (**EXT**). If external pressure function is sensed on **CH1**, it will keep this function. If external pressure function is not sensed, **CH1** will show the measured internal pressure.

CH2 is set to Current source.

This task is typically for the calibration of I/P pressure converters.

3.1.5 P - Display (Pressure to Display)

This sets **CH1** to show measured pressure from either the internal (**INT**) or external (**EXT**) sensors. If external pressure function is sensed on **CH1**, it will keep this function. If external pressure function is not sensed, **CH1** will measure internal pressure.

CH2 is set to **Observed** function.

This task is typically for the calibration of pressure devices with no electrical output but which have a visual indication of measured pressure.

3.1.6 Leak Test

This sets **CH1** to show measured pressure from either the internal (**INT**) or external (**EXT**) sensors with the **Leak Test** utility. If external pressure function is sensed on **CH1**, it will keep this function. If external pressure function is not sensed, **CH1** will measure internal pressure.

CH2 function does not change.

For more information about the **Leak Test**, refer to Section 7.1 on page 95.

3.1.7 Switch Test

This sets **CH1** to show measured pressure from either the internal (**INT**) or external (**EXT**) sensors, while the **Switch Test** utility data is shown on **CH2**. If external pressure function is sensed on **CH1**, it will keep this function. If external pressure function is not sensed, **CH1** will show the measured internal pressure.

For more information about the **Switch Test**, refer to Section 7.2 on page 98.

3.1.8 TX SIM (Transmitter Simulation)

This sets **CH1** to show measured pressure from either the internal (**INT**) or external (**EXT**) sensors. If external pressure function is sensed on **CH1**, it will keep this function. If external pressure function is not sensed, **CH1** will measure internal pressure.

CH2 is set with Current source (in transmitter simulation mode).

For more details on the **TX SIM** task, refer to Section 7.3 on page 100.

3.1.9 Relief Valve Test

This sets **CH1** to show measured pressure from either the internal (**INT**) or external (**EXT**) sensors, with the **Relief Valve Test** utility. If external pressure function is sensed on **CH1**, it will keep this function. If external pressure function is not sensed the measurement mode will be for internal pressure.

CH2 function does not change.

For more details on the **Relief Valve Test**, refer to Section 7.4 on page 102.



3.2 Tasks Selection

To automatically set one of the options on the **Tasks** menu, first tap the wanted option to select it. Tap the option again to start the function that sets the selected task. This is effectively a two-tap action that is done quickly. To use the Navigation Pad buttons: use the

UP/DOWN/LEFT/RIGHT buttons to select the wanted task and push the Navigation Pad  Enter button to start the function that sets the selected task.

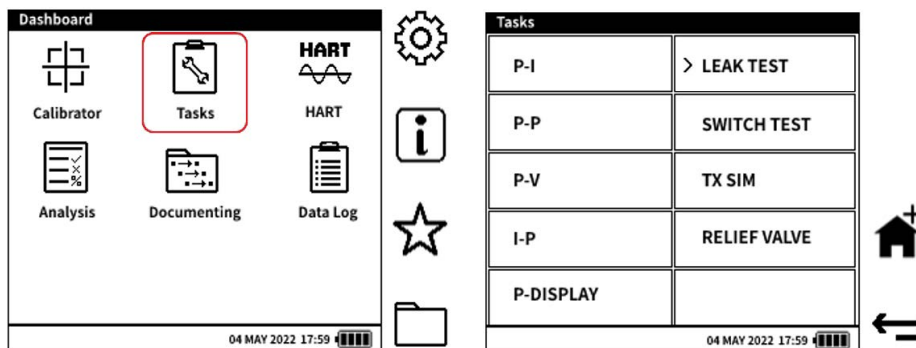

3.3 How to Add Tasks to the Dashboard

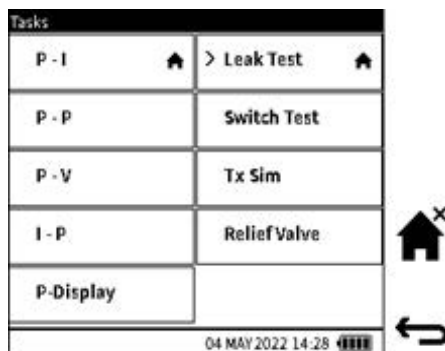

You can add up to three more tasks from the **Tasks** menu to the Dashboard (Home) screen as a shortcut. To add a **Task** option to the Dashboard, tap to select the wanted Task, then select the **(HOME+)**  Softkey to add the selected option to the Dashboard. To use the Navigation Pad buttons: use the **UP/DOWN/LEFT/RIGHT** buttons to select the wanted task and push the  icon to add the selected option. A small Home +  icon next to the option text shows that the **Task** option has been added to the Dashboard.

3.4 How to Remove Tasks from the Dashboard



You can only remove from the Dashboard the Tasks added through the **Tasks** menu. To remove a **Task** option: from the **Tasks** menu, tap to select the related Task, then select the  icon to remove the selected option. To use the Navigation Pad buttons, use the **UP/DOWN/LEFT/RIGHT** buttons to select the wanted task. Then push the  Softkey to remove the selected option and its related small **HOME**  icon.

4. General Settings

Select the **General Settings**  icon to show these DPI610E settings:

Setting	Description
DATE/TIME	Set the date/time.
LANGUAGE	Set the language.
BACKLIGHT	Turn the back light on/off.
COMMUNICATIONS	Select one of the USB communication modes or the Bluetooth mode.
AUTO POWER DOWN	Enable/disable Auto Power Down.
TOUCHSCREEN LOCK	Enable/disable Touchscreen Lock.
ENABLE HOLD	Enable/disable Hold.
ADVANCED	To get access to the Advanced Menu.

Note: To get access to the **General Settings** menu from the Dashboard, tap the  icon on the Touchscreen or push the related Softkey as shown below:

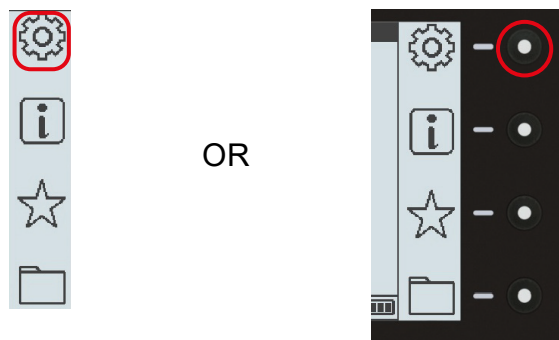

Tap the  icon on the Touchscreen OR push the Softkey for the **General Settings** icon.

4.1 DATE, TIME and LANGUAGE

To change the Date, Time and Language settings, see “Set Date, Time and Language” on page 16 and page 17.

4.2 BACKLIGHT

This function controls the instrument backlight. The DPI610E is usually set to **Timed (5 Minutes)**.

To change this value of this function:

1. Select **Backlight** from the **General Settings** menu.
2. Select the wanted mode (shown below).
3. Select  to make the selection.

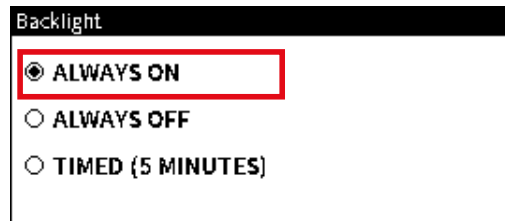

- **ALWAYS ON** sets the backlight to stay on when the instrument is energized, unless the battery power becomes too low.
- **ALWAYS OFF** sets the backlight to stay off at all times when the instrument is energized.
- **TIMED (5 MINUTES)** sets the backlight to stay on and automatically switch off after a period of 5 minutes of no use.

4.3 COMMUNICATIONS

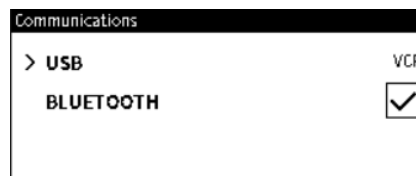

The **Communications** screen has two options.

1. Select the **USB** option to show two USB modes:
 - **USB - MASS STORAGE** mode for the transfer of files/folders between the instrument and a PC. This is the automatic USB setting when the DPI610E is energized.
 - **USB - VIRTUAL COMMS PORT (VCP)** Communications mode.
2. Tap the ✓ icon to select the **BLUETOOTH** mode.

BLUETOOTH is a wireless technology standard for the transfer of data between devices over short distances. Bluetooth is an option that must be bought pre-installed with the DPI610E. The DPI610E transmits a signal when the Bluetooth mode is selected. Another device, that also has Bluetooth energized, senses this signal and makes a Bluetooth connection with the DPI610E. This device can then communicate with the DPI610E by transmission of DUCI commands through the Bluetooth connection.

A device with a Bluetooth capability can receive data at a distance of up to 5 m from the DPI610E. Bluetooth devices can read the DPI610E channel configuration and its measurements.

4.4 AUTO POWER DOWN

This function controls how the instrument de-energizes. The DPI610E is set to automatically stay on until de-energized by the user.

To change this setting:

1. Select **Auto Power Down**.
2. Select one of the three modes.
3. Select ✓ to make the selection.

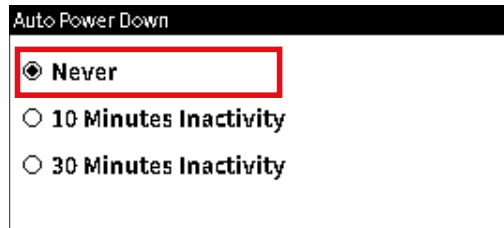

- **Never** sets the instrument to stay energized until de-energized by the user.
- **10 Minutes Inactivity** sets the instrument to automatically de-energize (switch off) after 10 minutes of no button presses.
- **30 Minutes Inactivity** sets the instrument to automatically de-energize (switch off) after 30 minutes of no button presses.

Note: Auto Power Down will not operate until all tests are done.

4.5 TOUCHSCREEN LOCK

This function lets the user lock the Touchscreen and use only the Navigation Pad and Softkeys to operate the instrument. The DPI610E automatically has the **TOUCHSCREEN LOCK** switched off.

To change this setting:

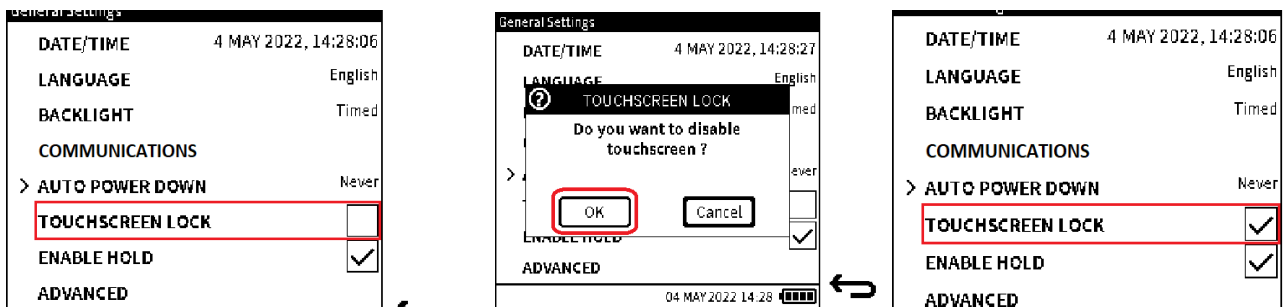

1. The **TOUCHSCREEN LOCK** has no Tick mark. Tap the empty checkbox.
2. Select **OK**.
3. The **TOUCHSCREEN LOCK** has a tick mark.

Note: To switch off the **TOUCHSCREEN LOCK**, tap on the Touchscreen 3 times in a period of 5 seconds.

4.6 ENABLE HOLD

This function lets the user control the mode of the **Hold**  Softkey when on the screen. The DPI610E automatically has **Enable Hold** selected.

To disable this function:

Chapter 4. General Settings

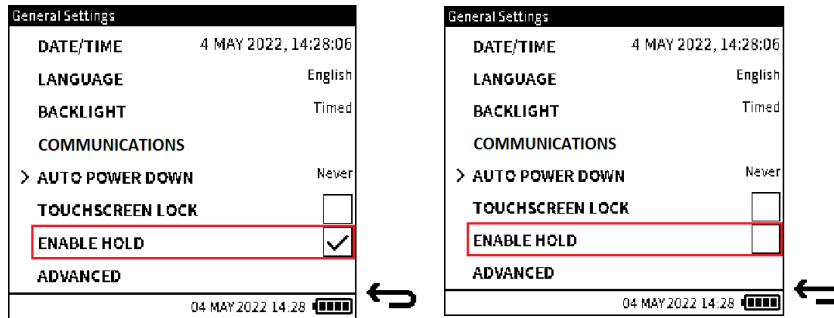

1. Tap on the **ENABLE HOLD** checkbox to remove the tick mark.
2. Select **OK**.
3. The **ENABLE HOLD** checkbox has no tick mark.

4.7 ADVANCED

This function gives access to the **Advanced Menu**. See Section 5 on page 41 for more details. To get access to the **Advanced Menu**:

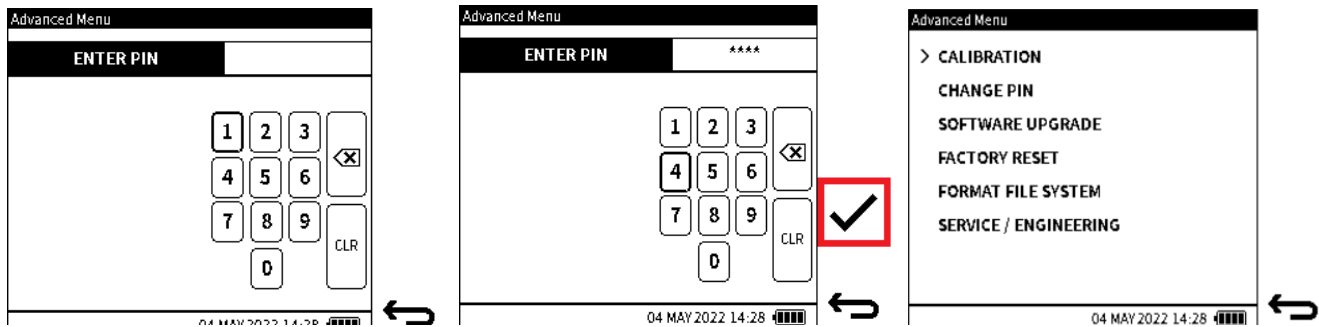

1. Enter the PIN. The necessary PIN is 4321. This default number can be changed by the user at all times. See Section 5.2 on page 41 for more information.
2. Select ✓ to continue.
3. The **Advanced Menu** screen is now unlocked and its options available (see Chapter 5, “Advanced Menu,” on page 41).

5. Advanced Menu

To get access to the Advanced menu, select **ADVANCED** from the **General Settings** menu (see Chapter 4.7, “ADVANCED,” on page 40).

The **Advanced** menu has these options:

Option	Description
*CALIBRATION	Calibration options
CHANGE PIN	Change the PIN
SOFTWARE UPGRADE	Start software upgrade
FACTORY RESET	Set the instrument back to default settings
FORMAT FILE SYSTEM	Erases all content on mass storage and makes factory default folders
SERVICE / ENGINEERING	Reserved for internal use

* A separate chapter describes the **Instrument Calibration** options that become available when CALIBRATION is selected. (See Chapter 14, “Instrument Calibration,” on page 229).

5.1 CALIBRATION Menu

The **INSTRUMENT** option is available in the **Calibration** screen (Figure 5-1). It allows you to do calibrations of the instrument and source functions:

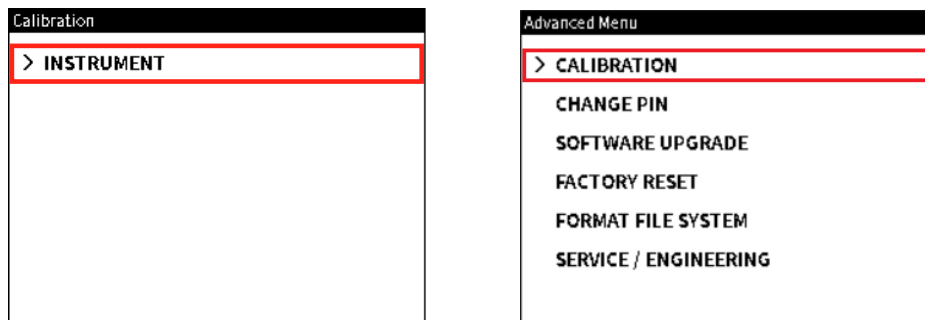

Figure 5-1: Calibration Menu

Note: Select **CALIBRATION** from the **Advanced Menu** screen to access the **CALIBRATION** menu (Figure 5-1) as shown.

Refer to Chapter 14, “Instrument Calibration,” on page 229 that describes the options available when this CALIBRATION menu becomes available for use.

5.2 CHANGE PIN

This option allows the user to change the instrument PIN number.

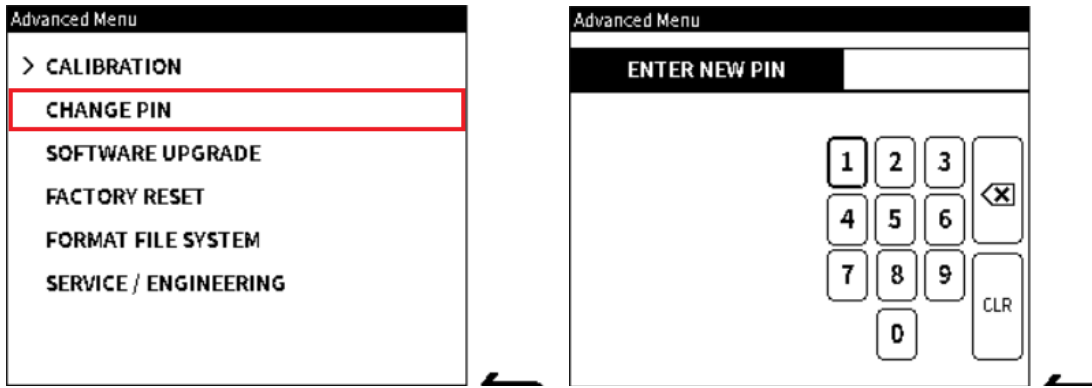

1. Select **CHANGE PIN** from the **Advanced** menu.
2. To change the PIN to a new number, use the on-screen keypad to enter the new number.
3. Select ✓ on the screen and enter the new PIN.
4. Select ✓ again to make the selection.



5.3 SOFTWARE UPGRADE

This option lets the user upgrade the firmware software of the instrument. Before this can be done, a software upgrade file must first be moved into the instrument.

5.3.1 How to load a Software Upgrade File

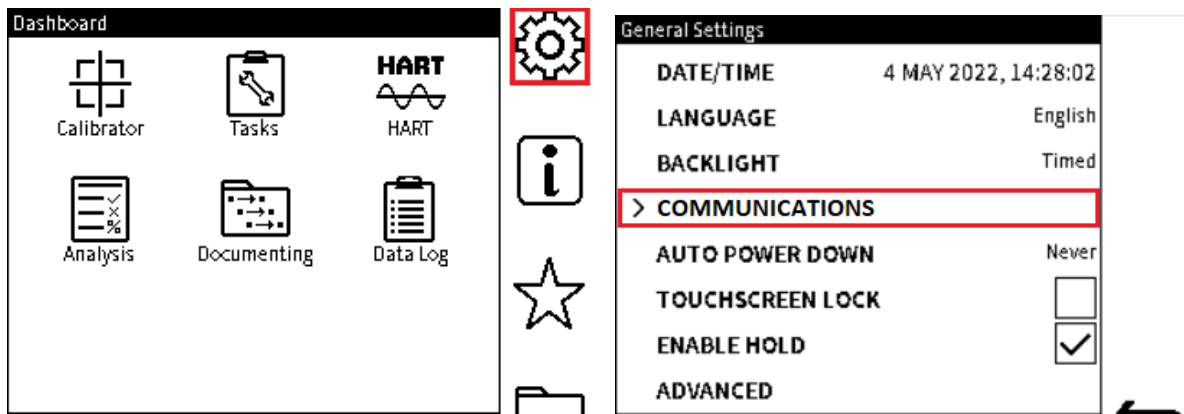
1. Download the “DK0492.raw” application image from <https://inspectionworks.com/druck-portal/#/store/public> on to the PC that is to connect to the DPI610E. Make sure the file name is not renamed.



2. Select the **Settings** icon  on the Dashboard. Push the **Home** button  if necessary, to show the Dashboard. To select, tap on the icon or push the Softkey to the right of the icon.
3. The **General Settings** screen appears. Select the **COMMUNICATIONS** option.

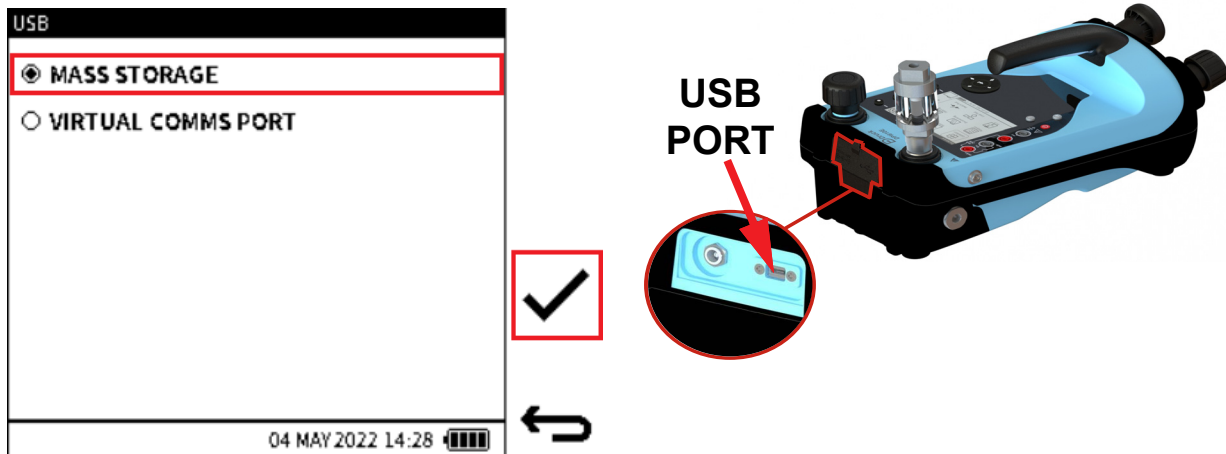

4. Select **MASS STORAGE**, then ✓ to make the selection.
5. Use a micro-USB data cable to connect the DPI610E to the PC.

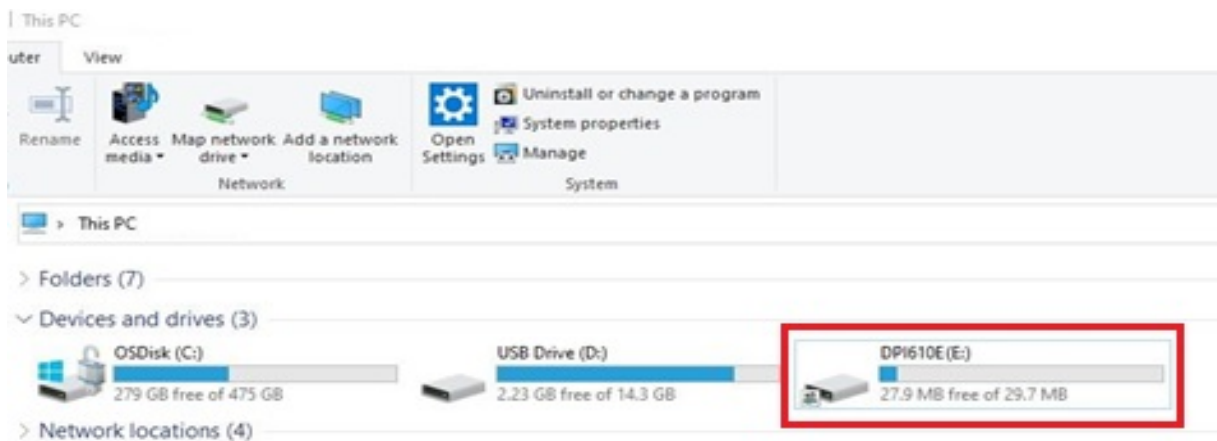

6. The PC will automatically sense the DPI610E. The screen will show the PC as a Mass Storage drive (default name of this drive is DPI610E).

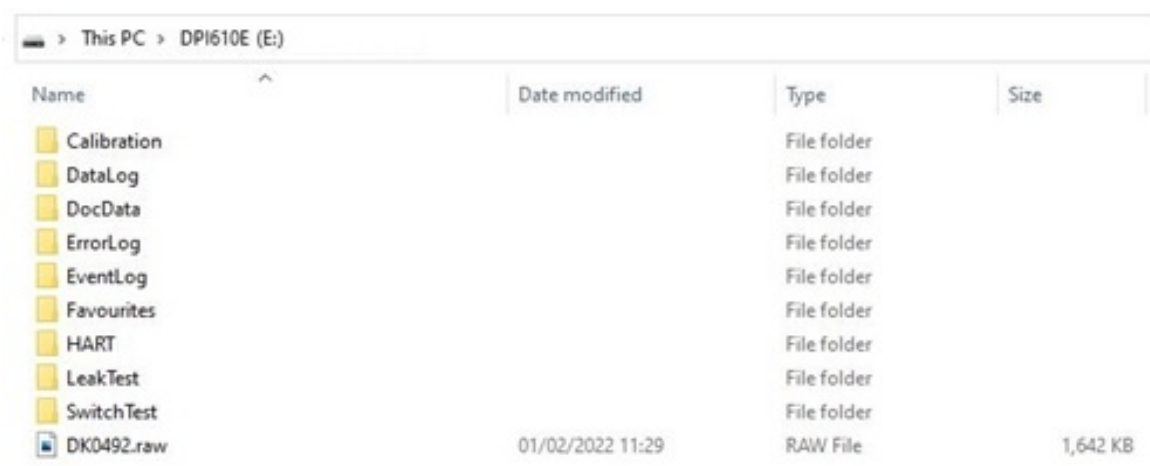

Chapter 5. Advanced Menu

7. Move a copy of the DK0492.raw file from the PC file system location into the root directory of the DPI610E mass storage drive. If an old DK0492.raw file is in the folder, a popup window will show this fact. Select **Overwrite** to replace the old file.
8. The screen must show that the DK0492.raw file is in the memory of the DPI610E. You can then remove the USB cable from the DPI610E.

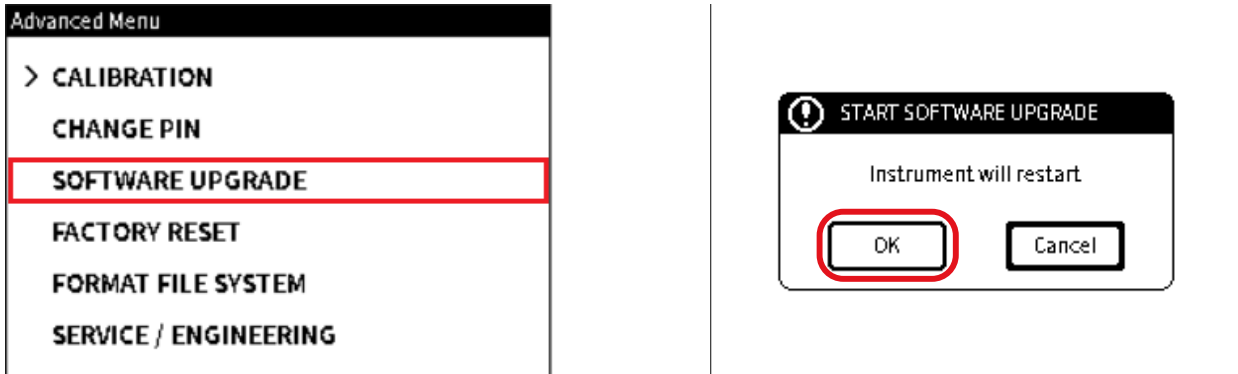

5.3.2 How to Upgrade the Firmware

Use this procedure to change the firmware (software embedded in hardware) to a new version:

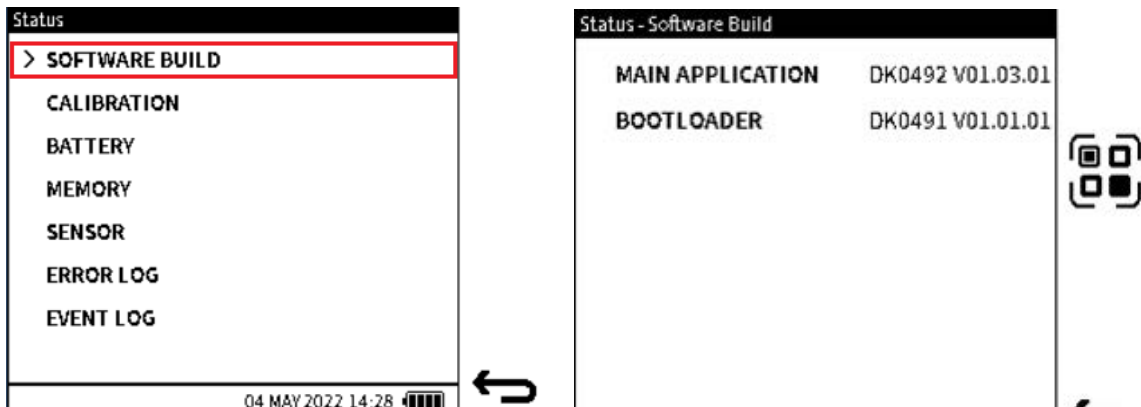

1. Select **SOFTWARE UPGRADE** from the **Advanced Menu** screen. Refer to Section 5.3.1 on page 42 for how to show this screen.
2. Tap the **OK** button to start the change procedure. This will reboot the DPI610E.



3. The DPI610E starts again and shows the **Dashboard** screen. Tap the Information (Status)  icon. The display then shows the **Status** screen. Select **SOFTWARE BUILD**.
4. The screen will show the versions of the DK0491 Boot-loader and DK0492 Application software. Look at these versions to make sure that they are correct. The  icon shows a QR image: a mobile phone can be used to scan this image. This will show a website on the screen. This screen gives instructions for how to change the application to a new version. Select  to show the **Status** screen again.



- If the screen shows the **Software Upgrade file not found** message, the system cannot find the file "DK0492.raw". The file must be in the instrument's root directory, for it to be found. Refer to the instructions at the start of this section for how to put a copy of this file into memory. Select the **OK** button to close this screen message. If you cannot change the software to a new version, contact the Technical Support Dept for instructions (see Chapter 1).

5.4 FACTORY RESET

This option lets the user set the instrument back to factory settings. It also has the option to remove all unwanted user files by this operation.

Note: Before using this option, make copies of files that are wanted for future use.

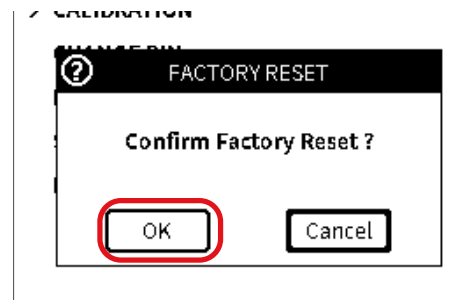
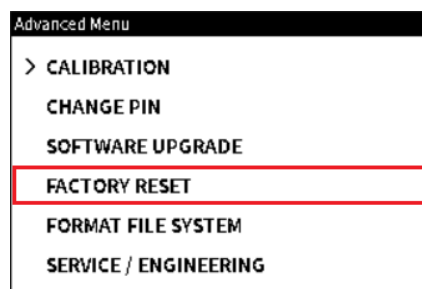

- Select **FACTORY RESET** from the **Advanced Menu** screen.
- Tap the **Cancel** button if the operation is not to continue. Select the **OK** button to make the **Factory Reset** operation occur.

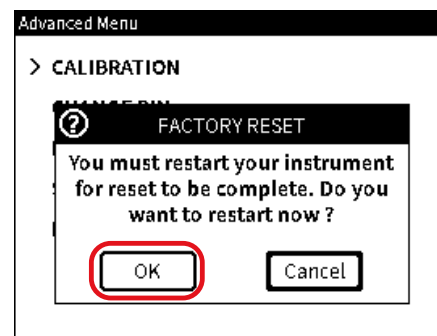
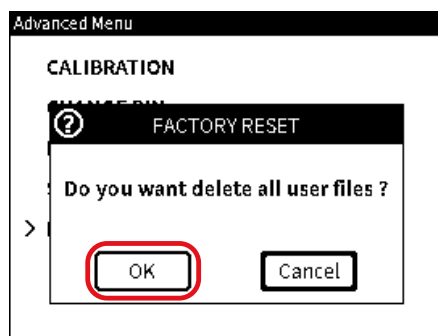

- Select the **OK** button to erase all user files.
- Select the **OK** button to start instrument again and complete the change operation. If you select **Cancel**, the change will be completed on the next start of the system.



5. Select the **OK** button to make the selection.

5.5 FORMAT FILE SYSTEM

The file system can be formatted if the instrument does not have sufficient storage space and a one-step clear-out is wanted. Save important files and the files in the HART folder and contents folders before the format operation (see section 5.3 to make copies of files). HART and context-sensitive help will not work correctly after the file system is formatted. To remove this problem, do an upgrade of the system or manually copy saved files back into their related folders.

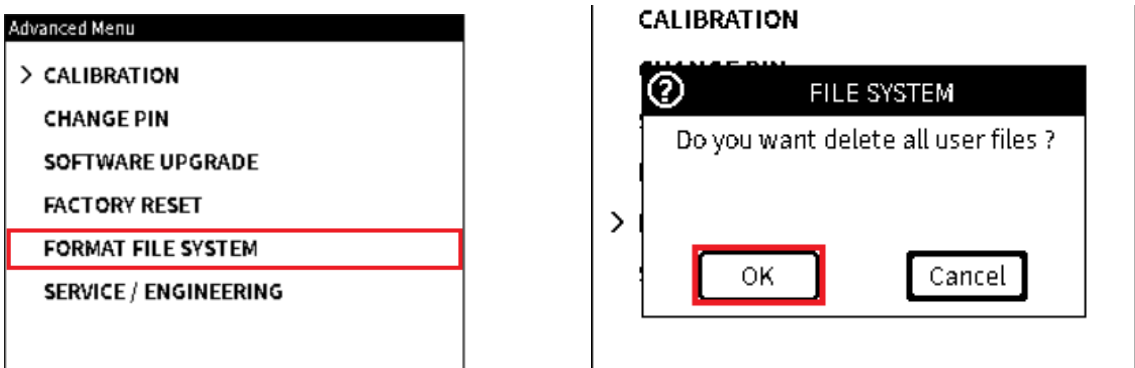

1. Select **FORMAT FILE SYSTEM** from the **Advanced Menu** screen. (Refer to Section 5.3.1 on page 42).
2. The screen shows a popup window. To let the file system be formatted, all user files must be erased. Tap the **OK** button to continue.

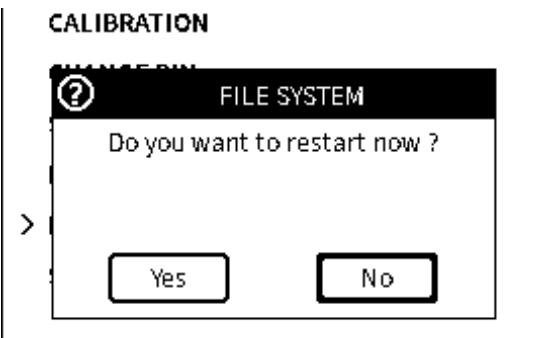

3. To start the instrument again and complete the format operation, select **Yes** in the popup message window. If you select **No**, the screen shows a popup message: **Formatting will be completed on next reboot**. Tap **OK** to close this message window. After the instrument is started, move all backup files back into their related folders.

5.6 SERVICE / ENGINEERING

This Advanced function is not for operator use. A special PIN is needed for use only by specialist users.

6. Calibrator Tasks

6.1 Calibrator Task Screen

The Calibrator screen has two areas that show the contents of two channels (**CH1** and **CH2**). These channels can show different combinations of measure/source functions.

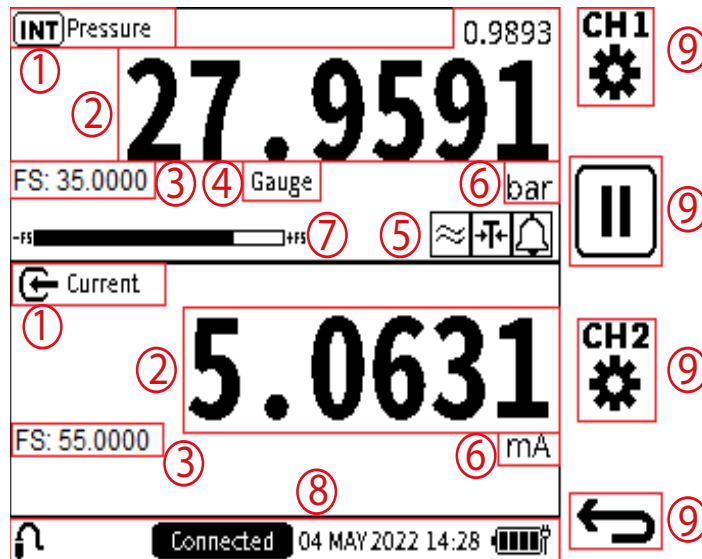
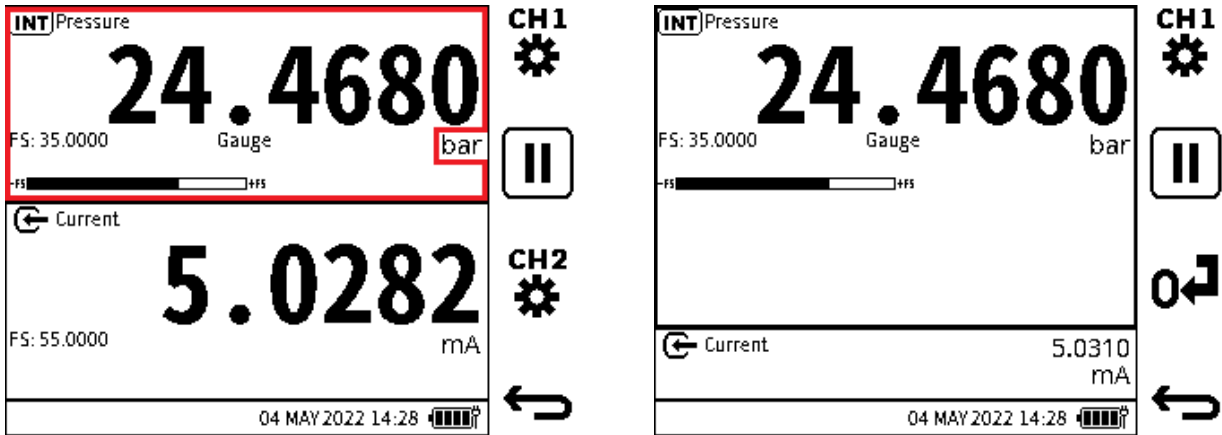

Figure 6-1: Calibrator Task Screen

1. **Function Name** – name of the selected function on the channel.
2. **Primary reading** – measured values that directly represent the channel function description and shown as large digits in the channel windows. A secondary reading can be in either channel window. This reading is in smaller digits just above the primary reading and shows the measured values related to the primary reading of the channel function.
3. **Full-scale value** – each function selected has a maximum measurement capability which is shown by the positive full-scale value. It is always in the channel window (with a prefix **FS:**).
4. **Sensor Type** – this is for pressure or temperature sensors. This field will show the pressure sensor type (Gauge, Sealed Gauge or Absolute) or RTD sensor, used by the channel function.
5. **Process Options** – these Process icons show each channel's Process options in use.
6. **Unit** – the Unit fields show measurement units of the primary (and secondary reading where applicable).
7. **Full-Scale Bar** – this bar gives a visual indication of the proportion of generated and measured pressure from the internal sensor of the full-scale range.
8. **Status bar** – the Status bar area is always shown in the user interface. This bar gives date and time information, and the amount of battery charge left. On the left side of the status bar, is more information about remote or external sensor connection status. Critical information such as a calibration overdue or an alarm condition can also be in this status bar.
9. **Softkey** – up to four Softkeys are available for the menu screens. These Softkeys give Touchscreen and button options for the use of different parts of the user interface.

6.2 Calibrator Tasks Screen Shortcuts

6.2.1 Maximize and Minimize Channel Window - Using the Touchscreen



When in the default 50:50 channel window layout, tap on any empty area on the wanted channel window (except the Units area) to maximize the window area. This will minimize the other channel window.



INFORMATION When in maximized or minimized layout, tap on the channel window area (but not the Units area) to show the 50:50 layout again.

6.2.2 Maximize and Minimize Channel Window - Using the Navigation Pad

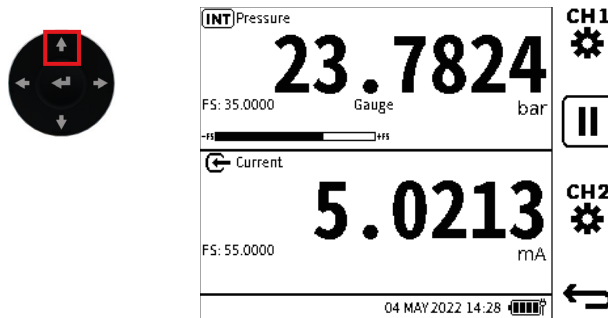

1. When in the default 50:50 channel window layout, push the **UP** button to select the Channel 1 (**CH1**) window area.



INFORMATION Push the **DOWN** button to select the Channel 2 (**CH2**) window area.

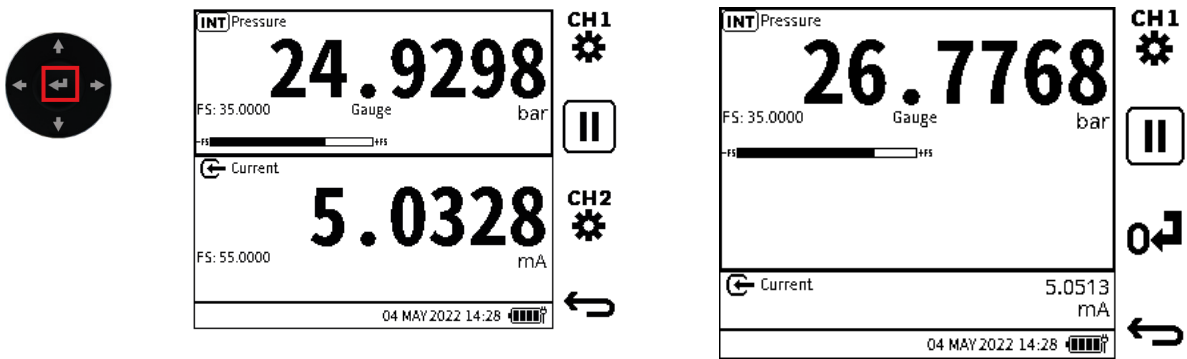

2. Push the **Enter** button to maximize the Channel window.



INFORMATION When in a maximized/minimized layout, push the **ENTER** button to show the 50:50 layout again.

6.2.3 Change Measurement Units

To change the measurement units on each channel on the calibrator task screen:

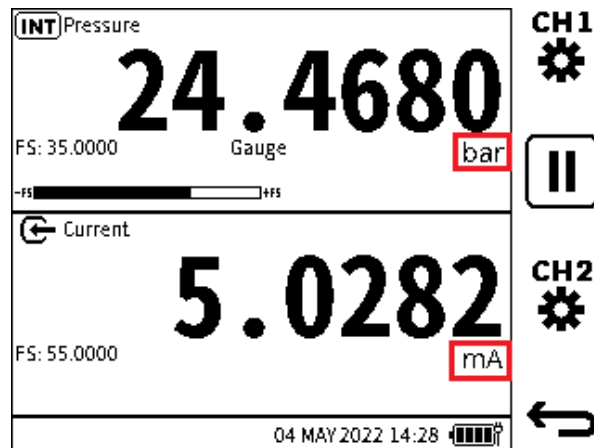

1. Select the Unit text on the related channel window. From the dashboard select:

CALIBRATOR > ^{CH1} or ^{CH2} > **UNITS**.

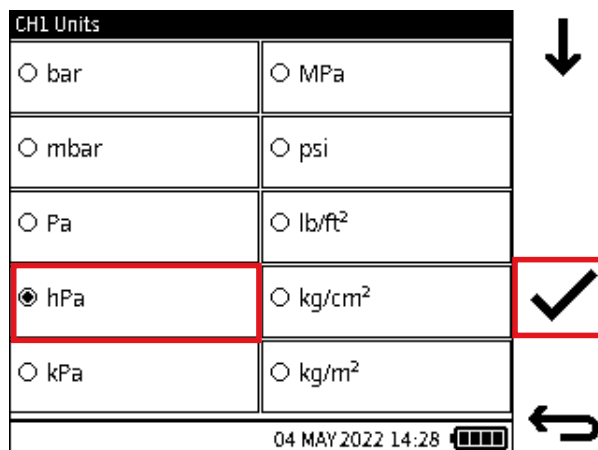

2. Select the wanted unit from the **CH Units** screen. Either tap the unit wanted on the screen or use the Navigation Pad arrow keys to select the unit. Select ✓ to make the selection.

Note: There are two types of the DPI610E. One type uses only SI units. The other type can use both SI and Non-SI units. An SI type can only show SI units on the screen.

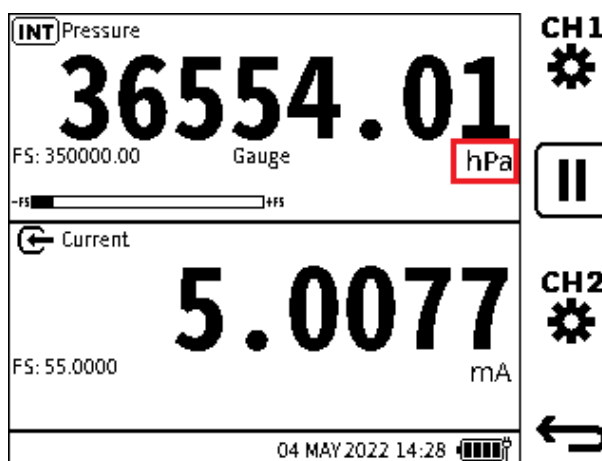

3. The selected channel window shows the wanted measurement unit.

Note: Section 2.1.7 on page 21 gives an alternative method to select units of measurement.

6.2.4 10 V/24 V Loop Power Enable/Disable

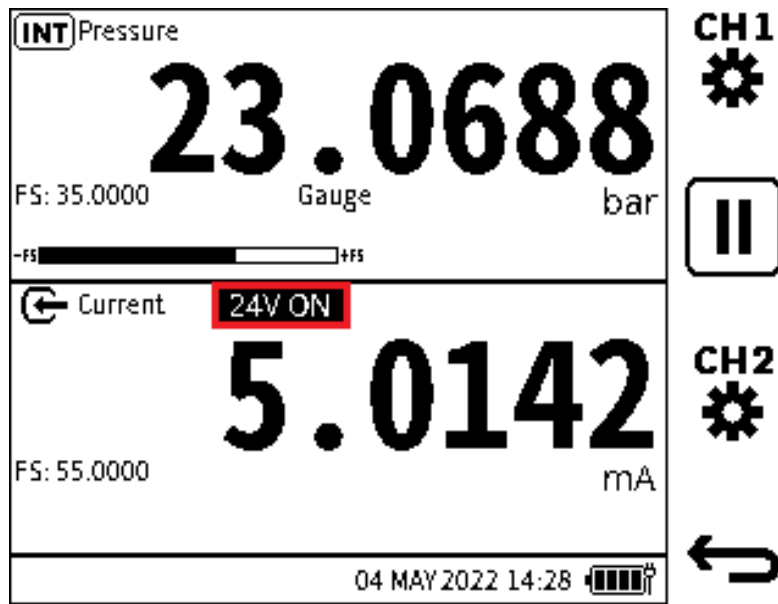

Figure 6-2: 24 V Loop Power Enabled

The Loop Drive is the internal power supplied by the DPI610E. It is available to use with all of the electrical functions given in the **CH2 Setup** screen. To make available the Loop Power, see Section 6.3.9 on page 65.

The type of Loop Power is use (10 V or 24 V) is shown at the top of the **CH2** channel window (see Figure 6-2).

You can quickly disable the **Loop Power** function without leaving the Calibrator Screen:

6.2.4.1 Loop Power Using the Touchscreen

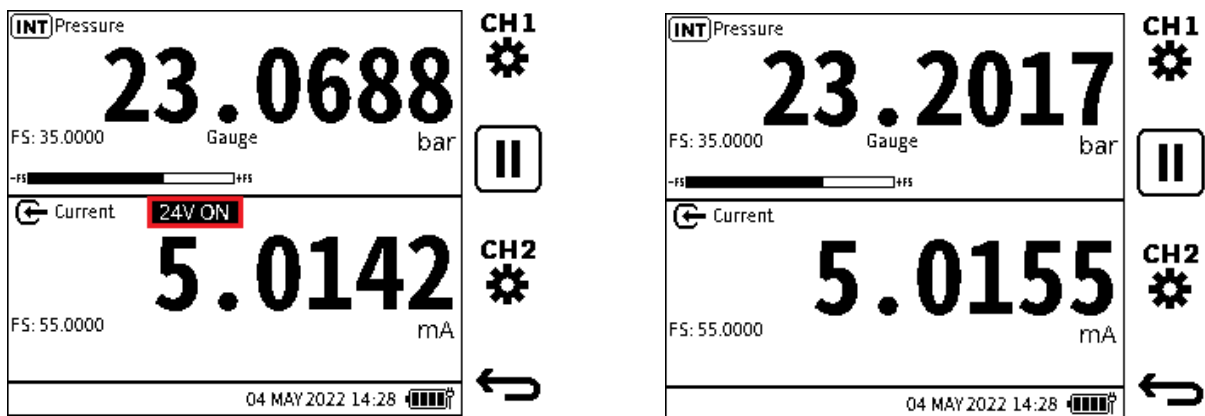

Tap on the **10 V/24 V** text field on the screen to select the loop power. Tap again on the **10 V/24 V** function to set the loop power off - shown by the removal of the voltage text field.

Chapter 6. Calibrator Tasks

6.2.4.2 Loop Power Using the Navigation Pad

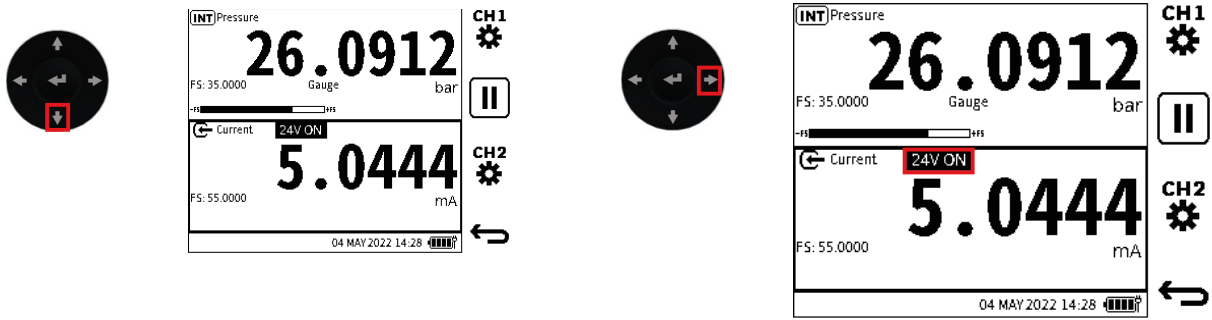

1. Push the **DOWN** button to select the **Channel 2** window area.
2. Push the **RIGHT** button to select the **10V/24V** text area.

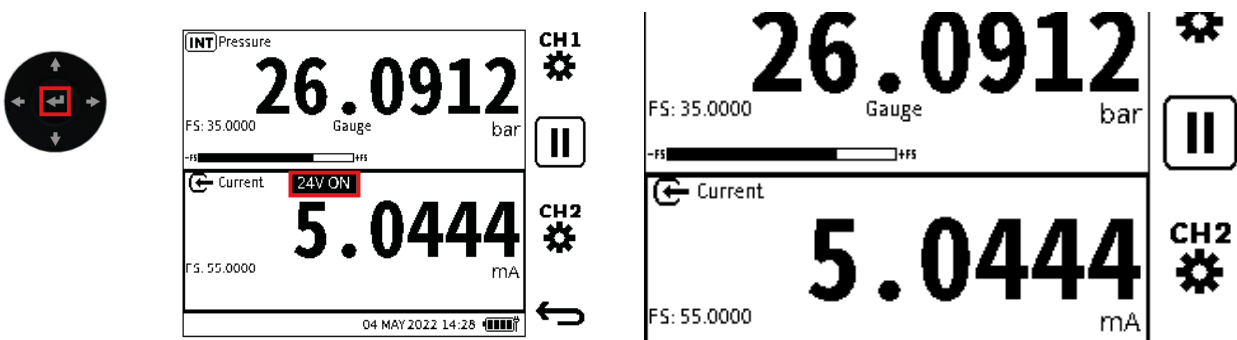

3. Push the **Enter** Key to cancel the **24 V ON** function.
4. Make sure that the **10 V/24 V** function is not in the screen after the function has been canceled.

6.2.5 Error Indications

An out-of-range error message occurs when the values of the primary reading measure are more than the full-scale value of the function range.

Table 6-1: Error Indicators

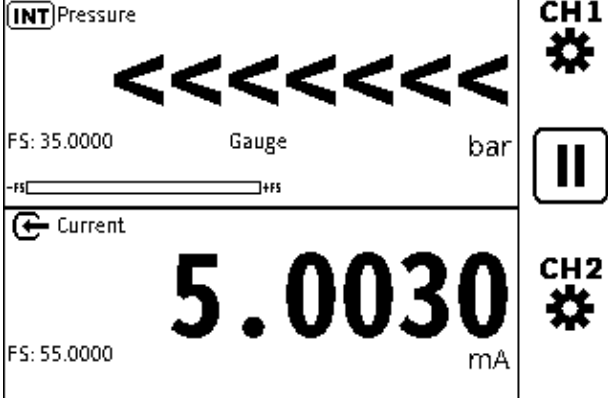
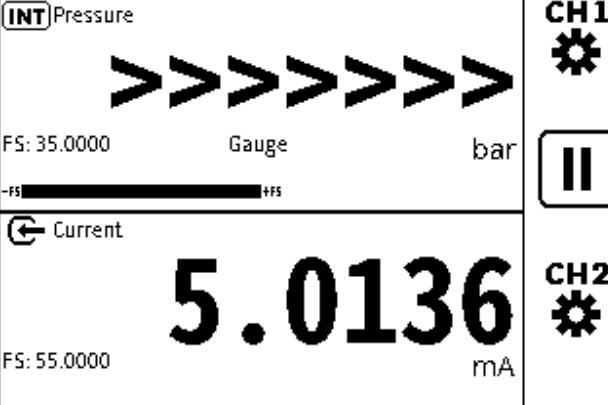
Condition	Description	Depiction
Under-range	Measured reading <110% of the negative full-scale value.	
Over-range	Measured reading >110% positive full scale.	

i **INFORMATION** If the screen shows any of the above error indications: look at the sensor/measurement full scale pressure range (shown on screen) against the range of the system being measured.

6.3 Functions

6.3.1 Functions Available by Channel

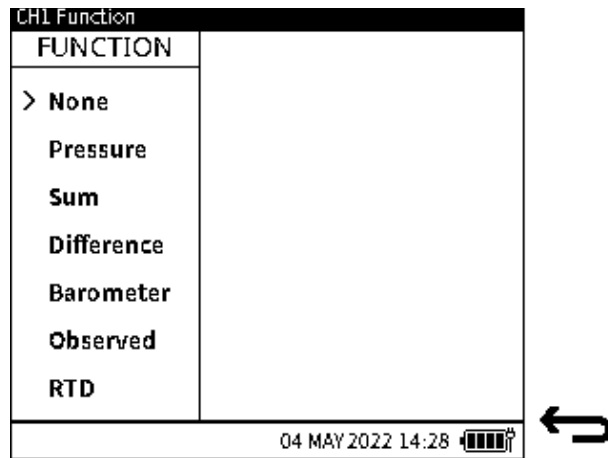

Figure 6-3: Channel 1 Functions

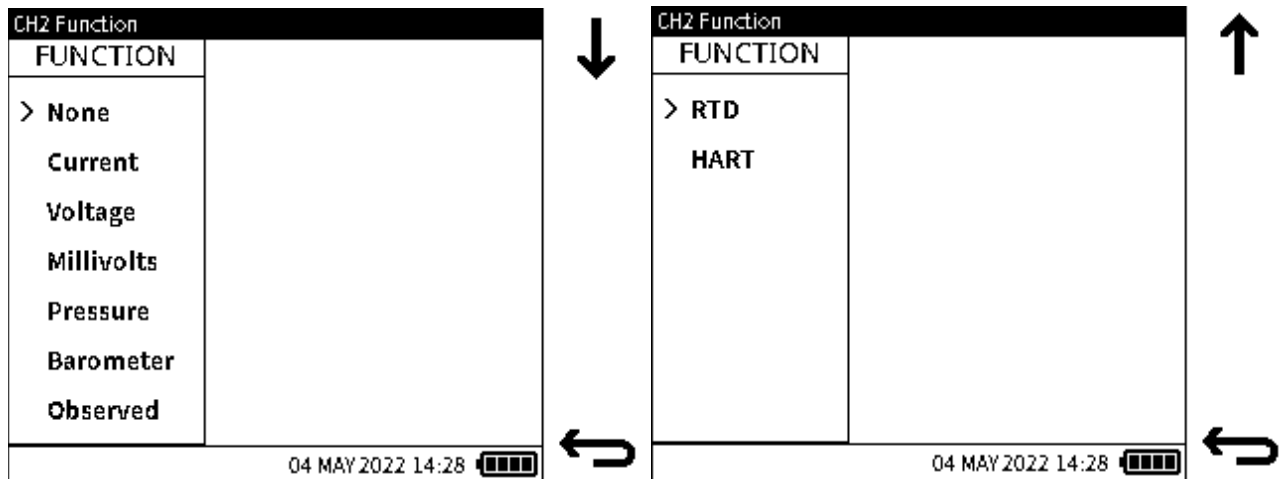

Figure 6-4: Channel 2 Functions

Figure 6-5 is a channel function combination matrix. This shows the combinations of channel selections that are available in the DPI610E product range.

		Channel 2										
		None	Electrical	Pressure				Barometer	Observed	RTD	HART	
				INT		Ext						
				Normal	Pseudo	Normal	Pseudo					
Channel 1	None	o	o	o	o	o	o	o	o	o	o	
	Pressure	INT	Normal	o	o	x	x	o	o	o	o	o
			Pseudo	o	o	x	x	o	x	x	o	o
		EXT	Normal	o	o	o	o	x	x	o	x	o
			Pseudo	o	o	o	x	x	x	x	o	x
	Sum	o	o	x	x	x	x	o	o	o	o	
	Difference	o	o	x	x	x	x	o	o	o	o	
	Barometer	o	o	o	x	o	x	x	o	o	o	
	Observed	o	o	o	o	o	o	o	o	o	o	
	RTD	o	o	o	o	x	x	o	o	x	o	

Figure 6-5: Channel Function Combination Matrix

Note:

- ‘Electrical’ includes Current, Voltage and Millivolt functions.
- ‘o’ shows a supported combination of functions.
- ‘x’ shows that a combination of functions is not supported.

6.3.2 None

Select this option if functions or readings are not to be shown on the channel. All readings and information will be removed from the channel window. Only the function name will remain.

6.3.3 Pressure

6.3.3.1 Internal Pressure

Pneumatic units contain internal pressure sensors which range from 350 mbarg to 35 barg. Hydraulic units contain internal pressure sensors which range from 70 bara/g to 1000 bara. Table 6-2 lists available internal pressure sensors.

Table 6-2: Internal Pressure Sensors in DPI610E Range

Pressure	Pressure Range Code	Pneumatic	Hydraulic
350 mbar / 5 psi / 35 kPa	03	G	-
1 bar / 15 psi / 100 kPa	05	G	-
2 bar / 30 psi / 200 kPa	07	G	-
3.5 bar / 50 psi / 350 kPa	08	G	-
7 bar / 100 psi / 700 kPa	10	G	-
10 bar / 150 psi / 1000 kPa	11	G	-
20 bar / 300 psi / 2 MPa	13	G	-
35 bar / 500 psi / 3.5 MPa	14	G	-
70 bar / 1000 psi / 7 MPa	16	-	G or A
100 bar / 1500 psi / 10 MPa	165	-	G or A
135 bar / 2000 psi / 13.5 MPa	17	-	G or A
200 bar / 3000 psi / 20 MPa	18	-	G or A

Chapter 6. Calibrator Tasks

Table 6-2: Internal Pressure Sensors in DPI610E Range

Pressure	Pressure Range Code	Pneumatic	Hydraulic
350 bar / 5000 psi / 35 MPa	20	-	A
700 bar / 10000 psi / 70 MPa	22	-	A
1000 bar / 15000 psi / 100 MPa	23	-	A

Table 6-3: Internal Pressure Sensors in DPI610E-A Range

Pressure	Pressure Range Code	Pneumatic	Hydraulic
2 bara / 30 psi / 200 kPa	07	A	-

6.3.3.2 To Set a Pressure Measurement Reading from an Internal Sensor

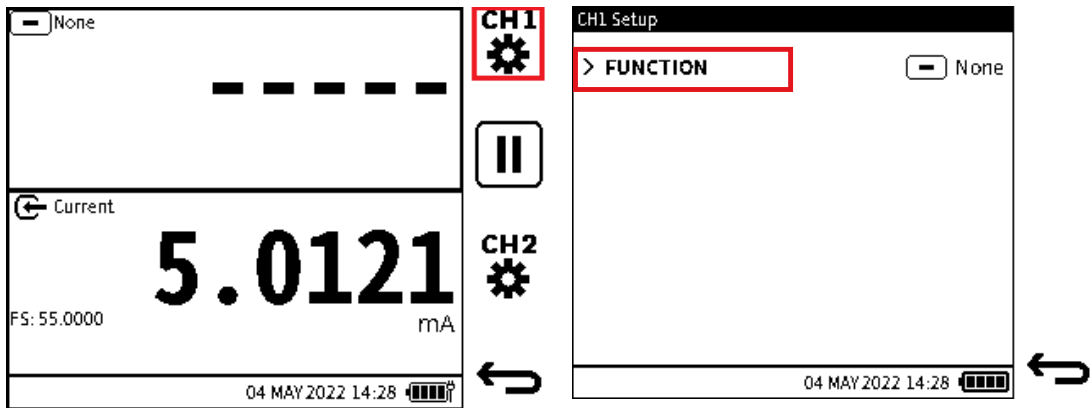

1. Select the wanted channel (Channel 1 in this example).
2. Select **FUNCTION** in the **Channel Setup** screen.

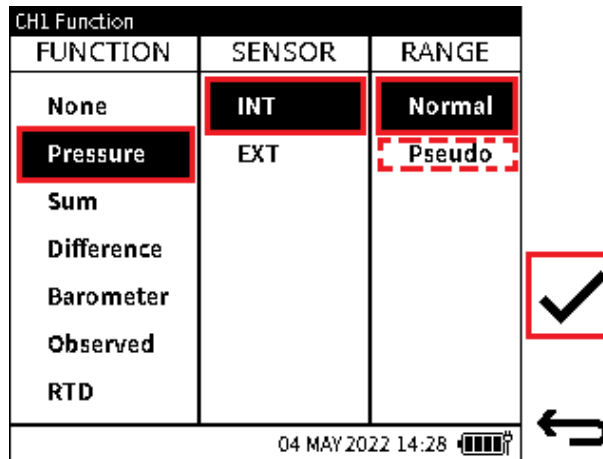

3. Select **Pressure** in the **Channel Function** screen. Select **INT** (for **Internal**). Select **Normal** or **Pseudo**. Select ✓ to make the selections.



INFORMATION See Chapter 6.3.3.6, “Normal and Pseudo Pressure Range,” on page 58.

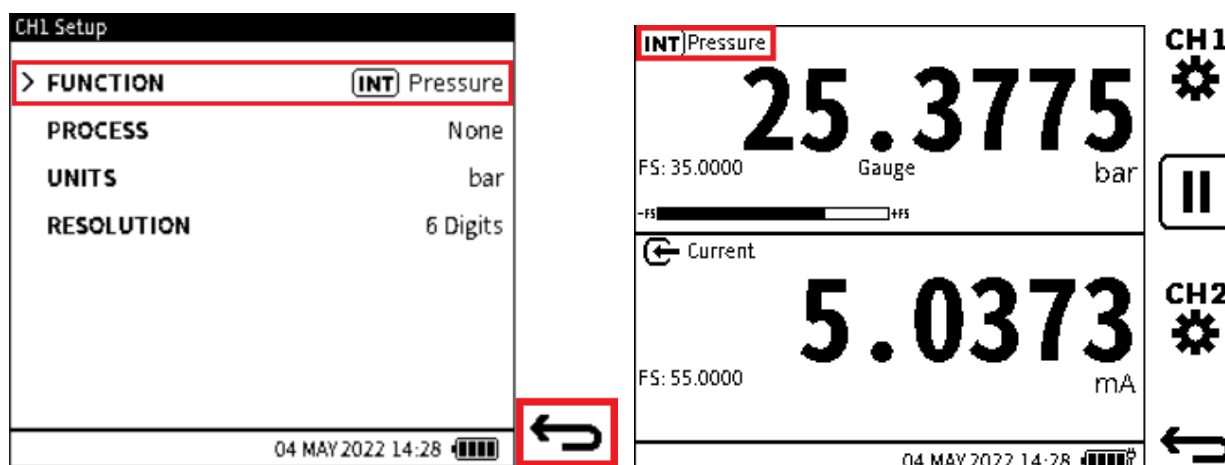

4. Make sure that the wanted values are in the **Channel Setup** screen. Select to go back to the **Calibrator** Main screen.
5. Make sure that the screen shows **INT Pressure** in the selected channel.

6.3.3.3 External Pressure

External pressure sensors (PM700E) are available in the range 25 mbarg/d to 1400 bara. Refer to “External Sensors” on page 131 for a list of available sensors. This source also gives information about how to set a DPI610E to sense and use external sensors and RTD probes.

6.3.3.4 The Zero Function

Use the **Zero** function on gauge sensors to remove offset drifts and thus use the highest accuracy.



INFORMATION The Zero function is only available for use with gauge sensors. It is not possible to use total vacuum for absolute sensors, because they are designed to measure atmospheric pressure.

Note: Zero all gauge sensors at the start of each day before use.

6.3.3.5 To Zero a Gauge Sensor

1. See Chapter 2.1.3 on page 19 for pneumatic units or Chapter 2.2.4 on page 31 for hydraulic units. Make sure that the sensor is open to atmosphere. Example: For the DPI610E internal sensor, open the Pressure Release Valve fully or make sure that the Test Port is open to atmosphere.
2. See Chapter 6.3.3.1 (INT) or Chapter 6.3.3.3 (EXT). Select the wanted pressure function (**INT** or **EXT**) from the **CH Setup** menu on **CH1** or **CH2**.

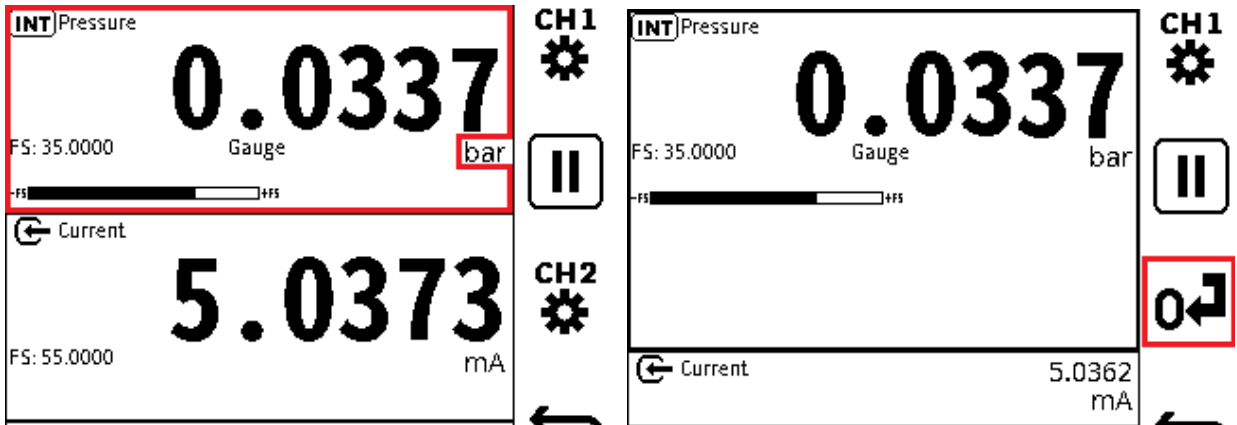

3. Tap in the channel window (except the Unit area) to maximize the pressure channel area (See Chapter 6.2.1, “Maximize and Minimize Channel Window - Using the Touchscreen,” on page 48).
4. Select **0** to set the pressure sensor to zero.

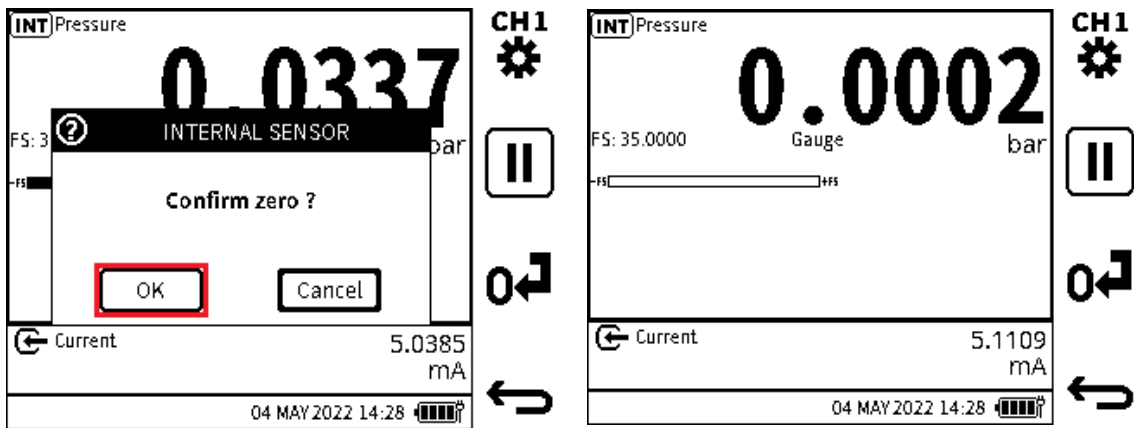

5. Select **OK** to continue.
6. Make sure that the wanted pressure channel has been zeroed.
Note: A Zero Error can occur if the pressure reading, measured from the sensor, is outside 1% of the full scale value when the instrument pressure port is opened to atmosphere.

6.3.3.6 Normal and Pseudo Pressure Range

Internal and external pressure sensors are either gauge (measurement made related to atmospheric pressure) or absolute (measurement made related to vacuum). The measured values from these sensors in their initial form are referred to as ‘Normal’.

The sensors in pneumatic instruments have an accurate barometer that continuously measures the atmospheric pressure. This measured reading can be used to convert the internal (or external if present) pressure sensor reading: from initially absolute to gauge or initially gauge to absolute. These pressure sensor modes are referred to as ‘Pseudo-gauge’ (initially absolute sensor to a gauge indication) and ‘Pseudo-abs’ (initially gauge sensor to absolute indication).

The hydraulic variants do not have the barometer as it is not usual to use gauge readings at the higher pressure at which these hydraulic variants operate. Thus, the hydraulic variants do not support ‘Pseudo-gauge’ or ‘Pseudo-abs’ ranges.

6.3.3.7 Sealed Gauge Pressure Range

Hydraulic variants with internal or external absolute pressure sensors up to 10 bar and above, can use an atmospheric reading to convert the sensor reading to gauge by Taring the atmospheric pressure value. This sensor mode is referred to as 'Sealed Gauge'. When a supported absolute pressure sensor is connected and sensed and the pressure function is set on either channel, a pop-up window is shown that gives the option to use the sensor in absolute or sealed gauge mode.

6.3.3.8 How to set an External Sensor as a Sealed Gauge (SG)



INFORMATION The EXT Pressure function must be set in one of the channels. The Calibrator mode must be used to start this popup message.

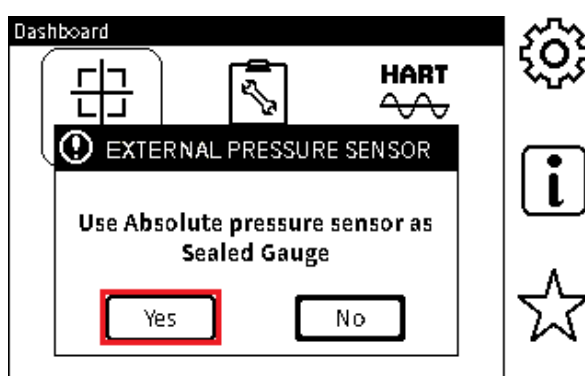

1. Switch on the instrument and select the **Calibrator** icon. When the display shows the popup window, select **YES**. If the instrument is already energized, select the **CH1** or **CH2** channel.



INFORMATION If **NO** is selected, the sensor will be used in its native form - as an Absolute pressure sensor.

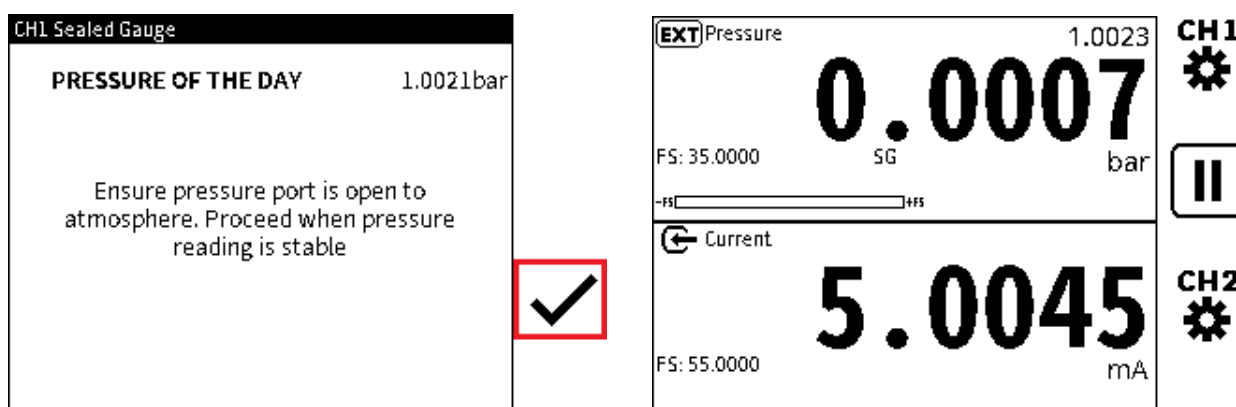

2. Make sure that the pressure port is open to atmosphere and start when the pressure reading is stable. Select ✓ to continue.
3. Make sure that Sealed Gauge (SG) is correctly set on the selected channel.

6.3.3.9 How to Set an Internal Sensor as a Sealed Gauge (SG)

i **INFORMATION** The INT Pressure function must be set in one of the channels and the Calibrator must be selected to start this popup message.

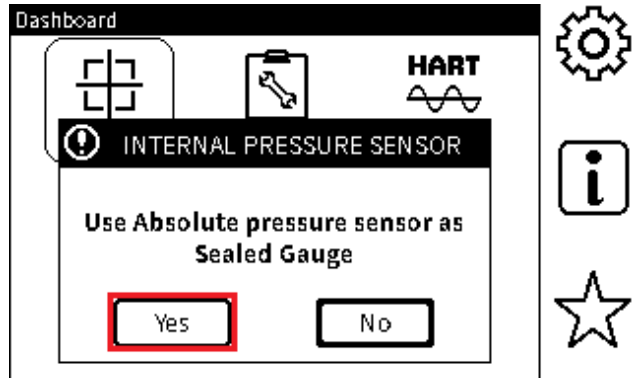

- 1. Select **YES**.

i **INFORMATION** If **NO** is selected the sensor will be used in its initial form - an Absolute pressure sensor.

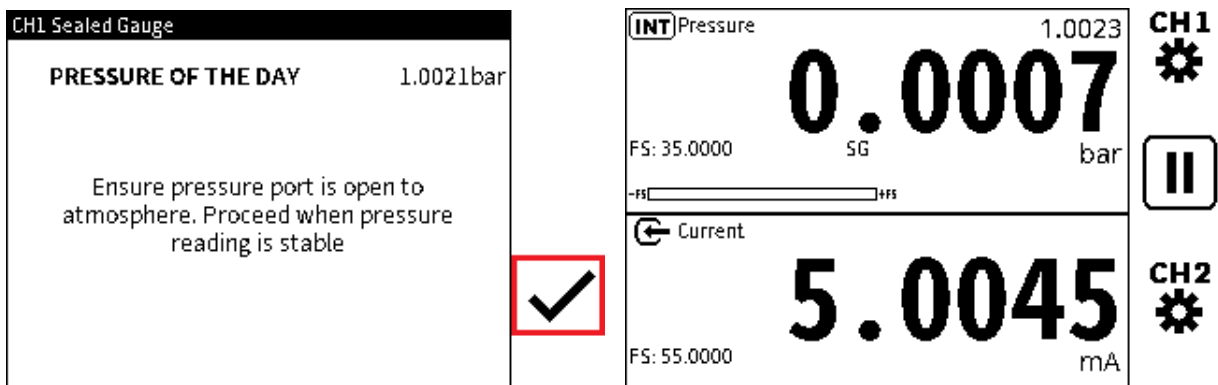

- 2. Make sure that the pressure port is open to atmosphere. When the pressure reading is stable, select the ✓ icon.
- 3. Make sure that **Sealed Gauge** (SG) is correctly set on the selected channel.

6.3.4 Sum

Sum is a function related to pressure. This function lets the internal pressure reading from the instrument to be mixed with the pressure reading from an external sensor. An external pressure sensor must be connected, to see the mixed reading on the **Calibrator Main** screen.

The **SUM** function is only available on **CH1**. If the **SUM** function is selected on **CH1**, the **INT** Pressure function or **EXT** Pressure function cannot be set on **CH2**.

Note: Be careful when both sensors are not gauge: make sure the effect of atmospheric pressure has been included.

6.3.4.1 How to Use the Sum Function to Set a Pressure Measurement Reading

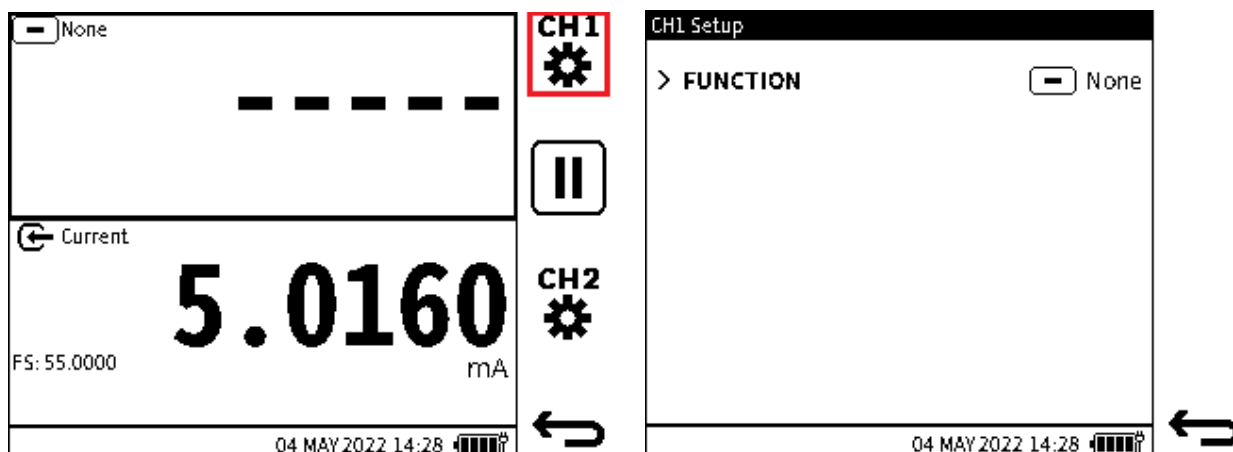

1. Tap the **CH1** icon to select Channel 1 or push the related Softkey.
2. Select **FUNCTION** from the **Channel Setup** menu.

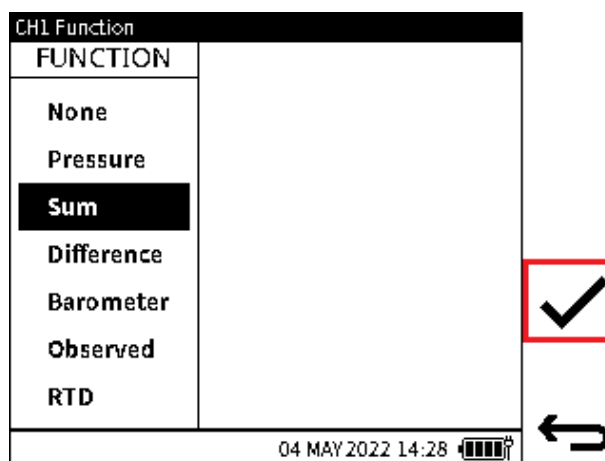

3. Select **Sum** from the channel **FUNCTION** menu. Select to make the selection. The display will show the CH Setup screen again.

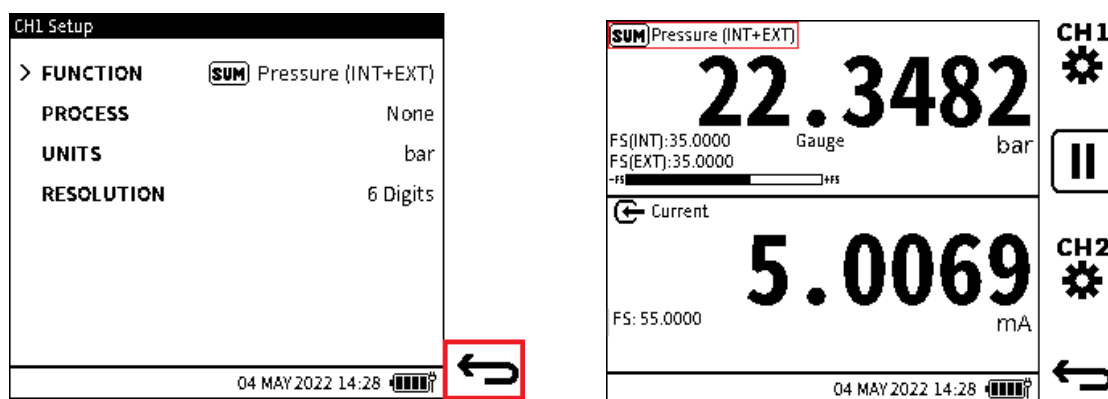

4. Make sure that the screen shows the wanted setup in the **CH Setup** menu. Select to go back to the Calibrator Main screen.

Chapter 6. Calibrator Tasks

6.3.5 Difference

Difference is a pressure related function. This lets the difference between the internal pressure sensor reading and the external pressure sensor reading to be shown on the calibrator task screen. An external pressure sensor must be connected to see the pressure reading.

Note: Be careful when both sensors are not the same type (absolute/gauge), to make sure to compensate for the contribution from atmospheric pressure.

6.3.5.1 To Set a Pressure Measurement Reading using the Difference Function:

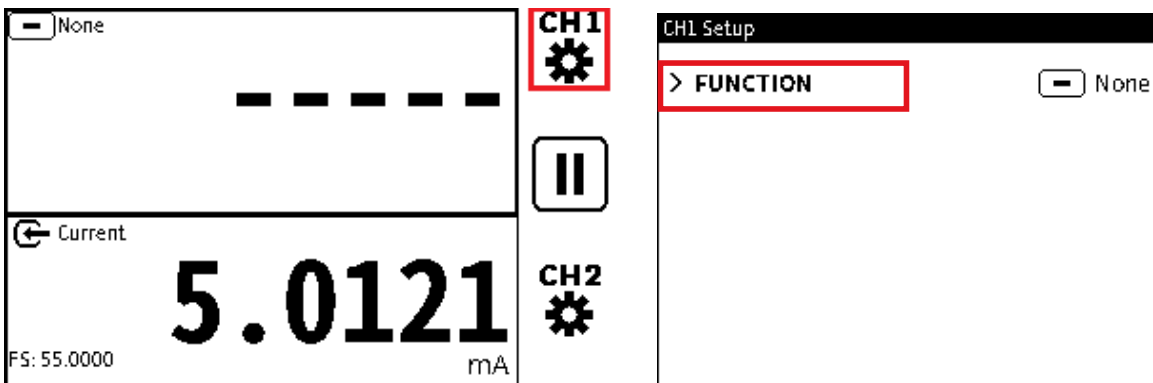

1. Tap the ^{CH1} icon to select Channel 1 or push the related Softkey.
2. Select **FUNCTION** from the **Channel Setup** menu.

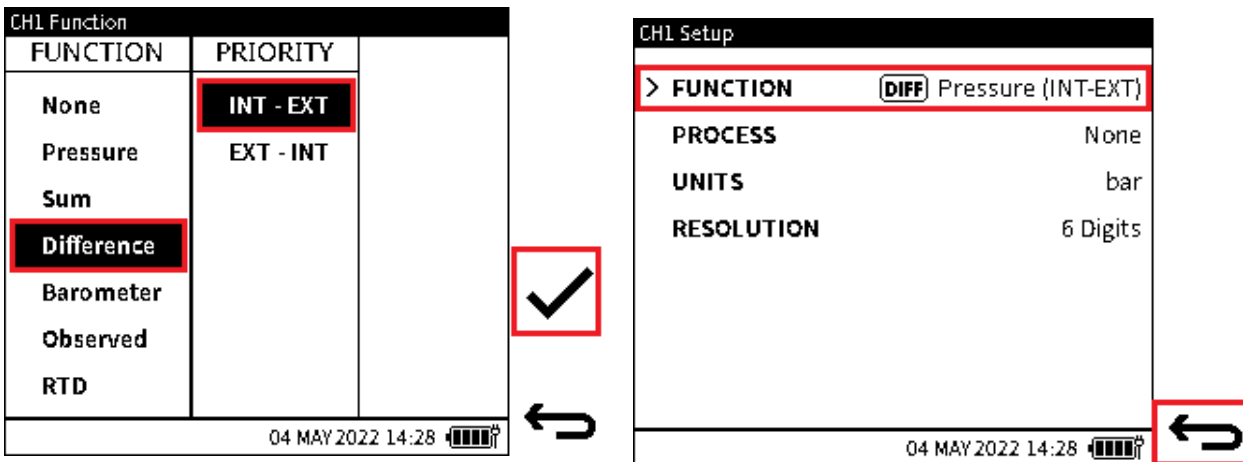

3. Select **Difference** from the **FUNCTION** menu. Select **INT-EXT** or **EXT- INT** as wanted. Select to make the selection.
4. Make sure that the screen shows the wanted setup in the **CH Setup** menu. Select to go back to the **Calibrator Main** screen.

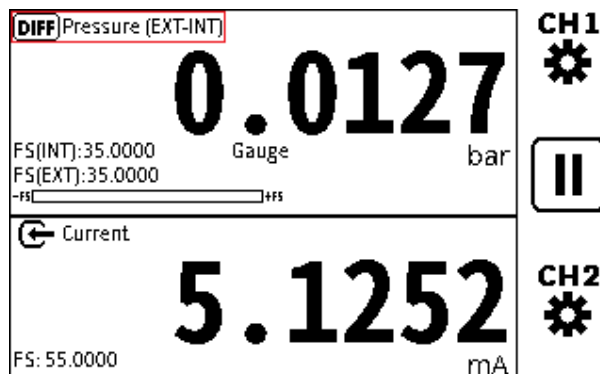

5. Make sure that the **Difference** function is correctly set on the wanted channel. The **Difference** **DIFF** icon together with the function name, will be Pressure (**INT-EXT**) or (**EXT-INT**). The screen will also show the **FS** values of both the internal sensor and the external sensor. The sensor type field will also be updated where necessary.

6.3.6 Barometer

The internal Barometer can measure a range of 750 to 1150 mbar. The **Barometer** function lets the screen show the measured atmospheric pressure on the **Calibrator Main** reading screen as a primary reading. The internal barometer is only available in the pneumatic variant of the DPI610E.

6.3.6.1 To Set a Pressure Measurement Reading using the Barometer Function:

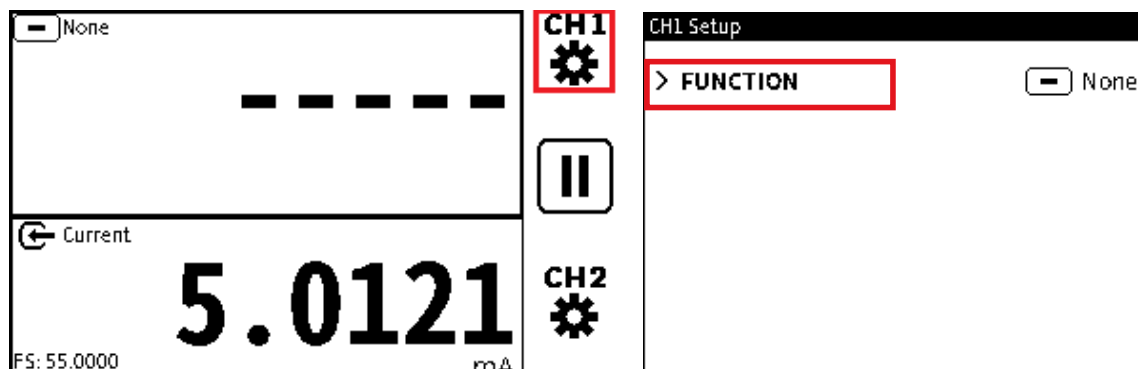

1. Select the **CH1** or **CH2** gear icon as wanted.
2. Select **FUNCTION** from the **Channel Setup** menu to show the **CHL Function** screen.

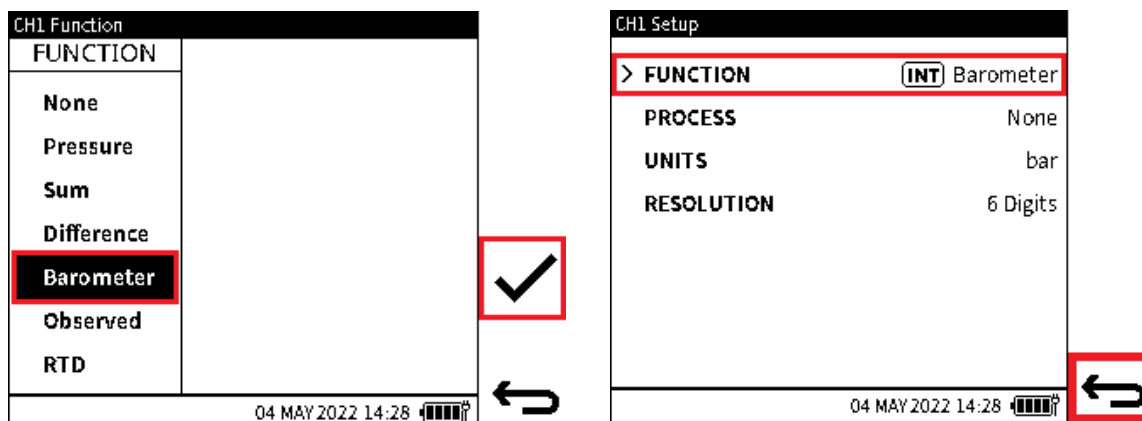

Chapter 6. Calibrator Tasks

3. Select **Barometer** in the channel **FUNCTION** menu. Select the **Tick** ✓ button to make the selection.
4. Make sure that the screen shows the **INT Barometer** function in the **CH Setup** menu. Select the **Back** ↩ icon to go to the Calibrator Main Screen.



5. Make sure that the **Barometer** function is correctly set in the wanted channel window.

6.3.7 Observed

A non-measured function with a range of +/- 999999.9. It lets you manually enter an observed reading from an external measurement and indicator device. It is frequently used together with a second measured function on another channel, to record the relationship between the two readings.

6.3.7.1 To use the Observed function to set a channel:

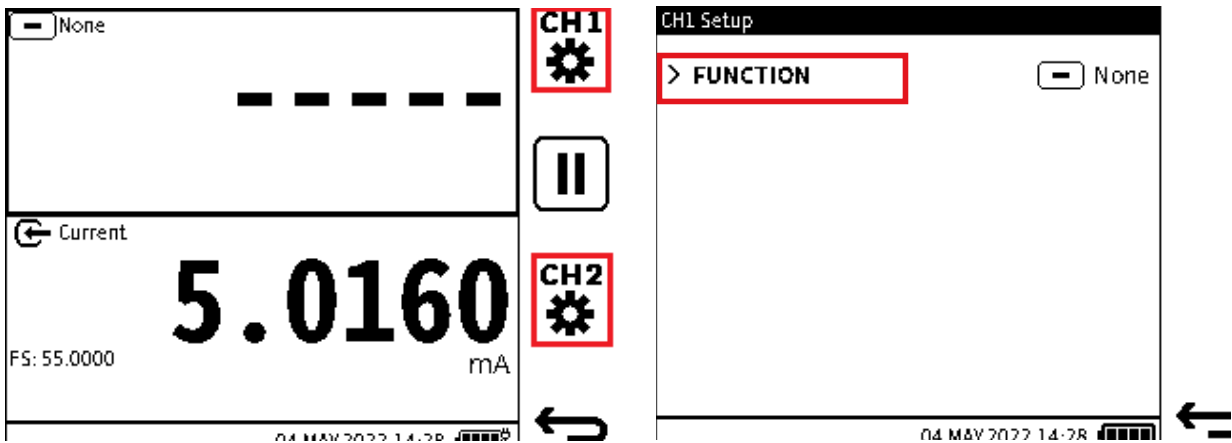

1. Select the **CH1** or **CH2** gear icon as wanted.
2. Select **FUNCTION** from the Channel Setup menu.

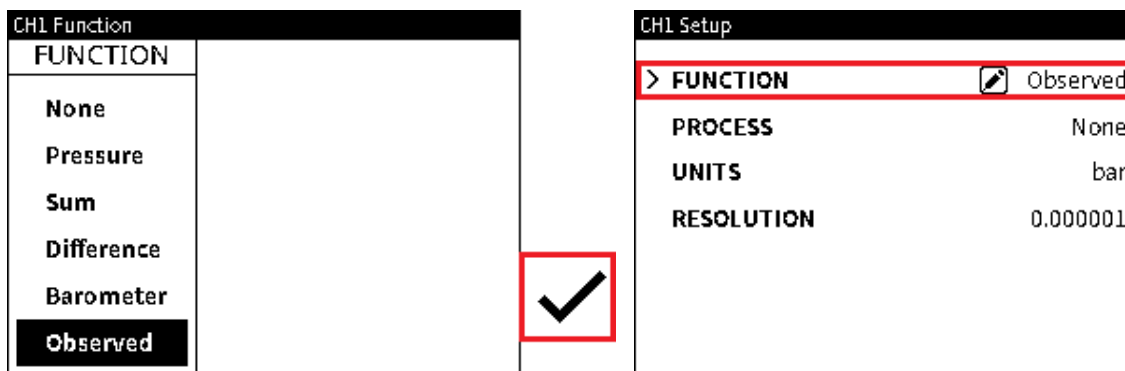

3. Select **Observed** from the channel **FUNCTION** menu. Select the Tick ✓ button to make the selection.
4. Make sure that the screen shows the **Observed** function in the **CH Setup** menu. Select ← to go back to the Calibrator Main screen.

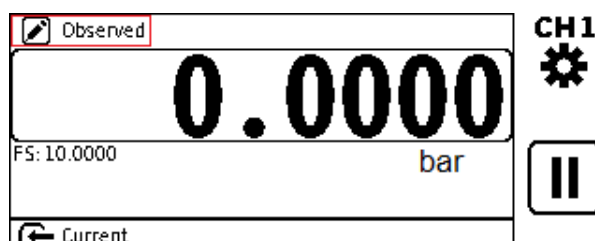

5. The screen will show the **Observed** message in the top left corner of the screen display. To select a different unit of measurement, refer to Section 6.2.3 on page 49 for instructions.

6.3.8 RTD

This function lets temperature or resistance measurements be shown on the **Calibrator** primary reading screen as a primary reading. This is possible when the RTD-Probe connects to the DPI610E through the RTD-Interface (or RTD-Interface-IS).

When the RTD-Interface connection is sensed, the sensor  icon is shown in the status bar and the “Connected” text briefly appears. This shows that there is a successful connection. When the cable is disconnected, the screen will remove the sensor icon and show a “Disconnected” text briefly: this shows that the connection is broken.

6.3.9 Current

The instrument can measure or source electrical current in milliamps (mA) on **CH2** only. When the **CH2 Current** function is used, you can also use the internal 10 V (non-IS instruments only) or 24 V power supply given by DPI610E. You can also use an external power supply for the device under test.

6.3.9.1 Current Measure

The DPI610E current measurement range is: +/- 55 mA.

You must use the correct terminals to set the **Current Measure** function:

Chapter 6. Calibrator Tasks

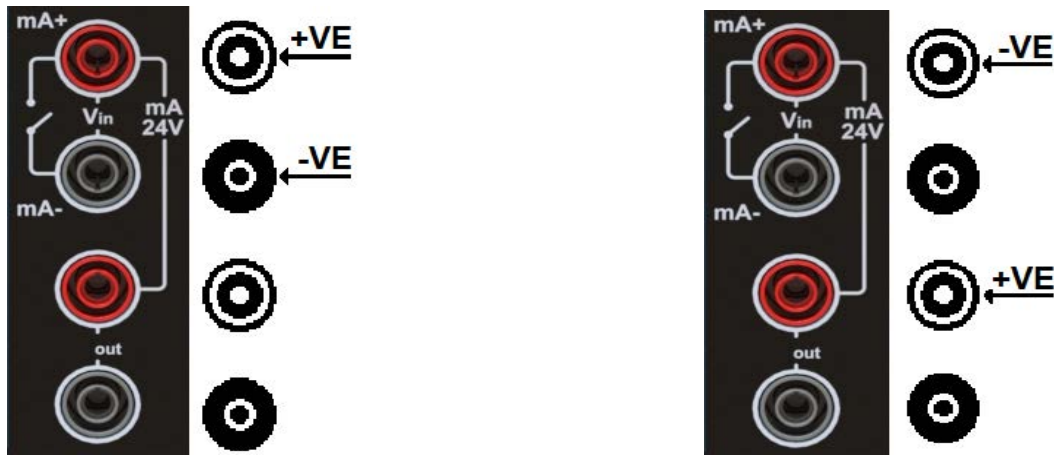

1. Use the diagram on the left to make the necessary connections for Current Measure when the 24 V internal power supply is not used (the Off option is selected in Step 4). Use the diagram on the right to make the necessary connections for Current Measure when the internal 24 V supply is used.

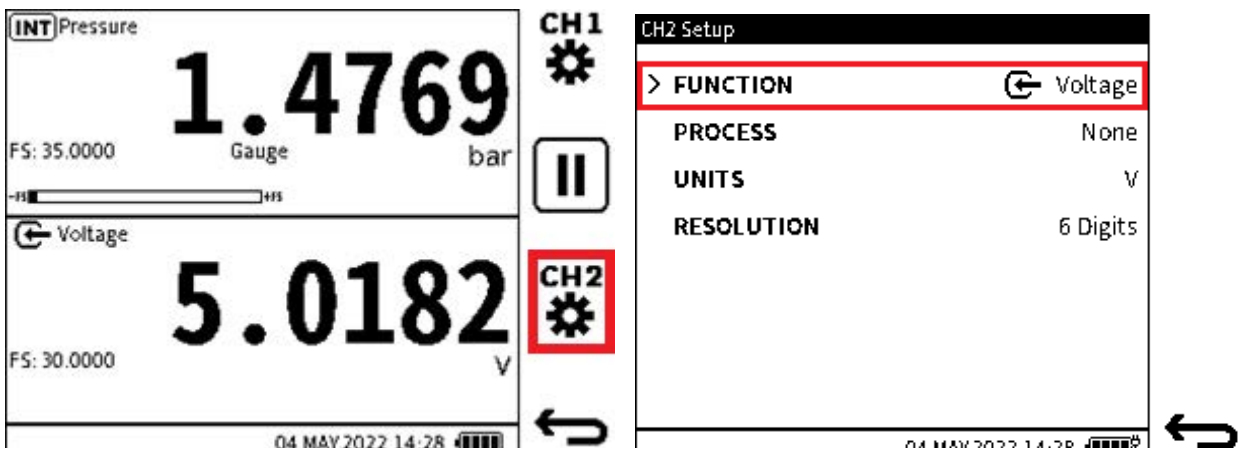

2. Select the CH2 channel.
3. Select FUNCTION from the CH2 Setup screen.

CH2 Function 1/2		
FUNCTION	DIRECTION	POWER
None	Measure	off
Current	Source	24V
Voltage		
Millivolts		
Pressure		

4. Select **Current** > **Measure** > then select one of the following:
10 V for measure with internal 10 V Loop Power supply (only for non-IS units)
 OR
24 V for measure with internal 24 V Loop Power supply.

Select ✓ to make the selection.

The electrical connections for the OFF selection will be different to those for when you select 24 V or 10 V (see Step 1).

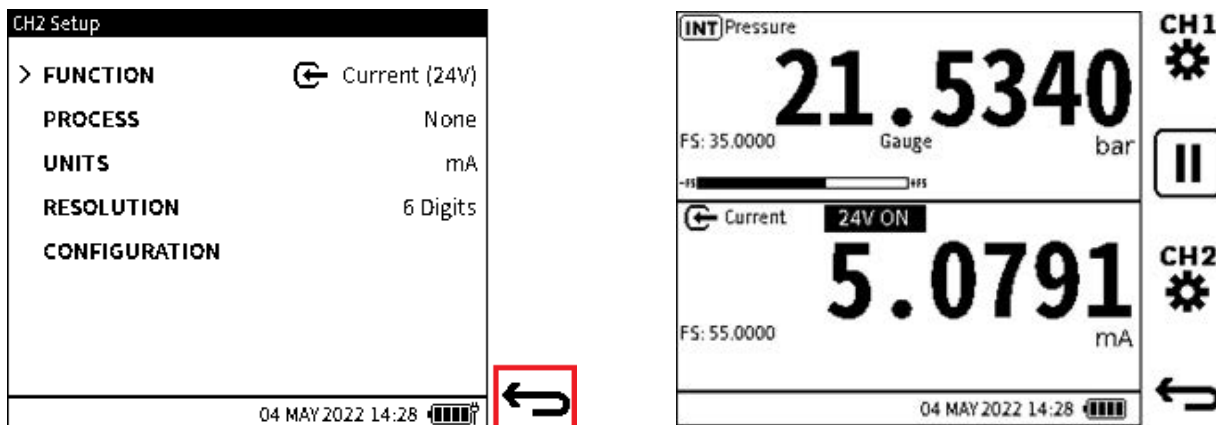

- This screen will have only **Current** as the Function with **Off** selected. When you select **24 V**, **Current (24 V)** will appear. Select the Back ↩ icon to go to the Calibrator Main Screen. The Calibration screen will show **24 V ON** in the **CH2** screen area. If **Off** has been selected, only **Current** will be in the top of this area.

6.3.9.2 Current Source

To set the **Current Source** function:

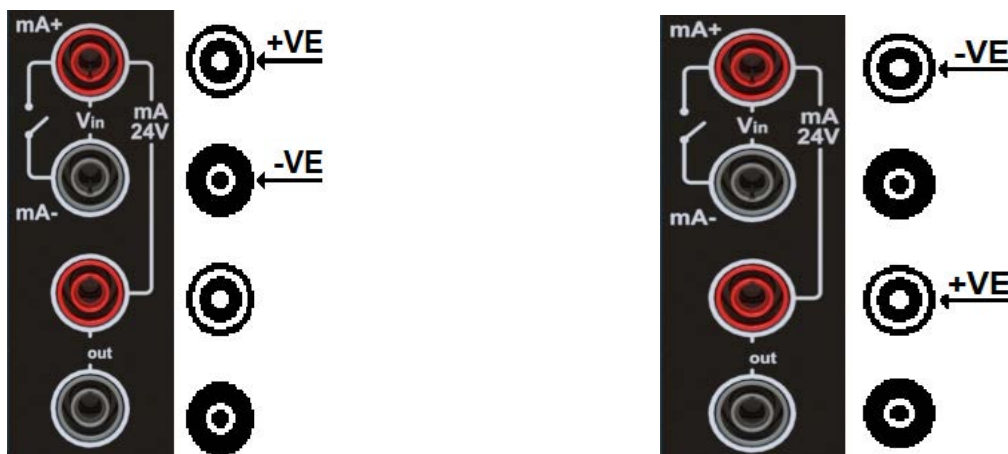

- Use the diagram on the left, to make the necessary connections to the Current Source. This is necessary when the 10 V/24 V internal power supply is not used (when the Off option is selected in Step 4). Use the diagram on the right to make the necessary connections to the internal 10 V or 24 V supply. This is the source of Current Supply.

Chapter 6. Calibrator Tasks

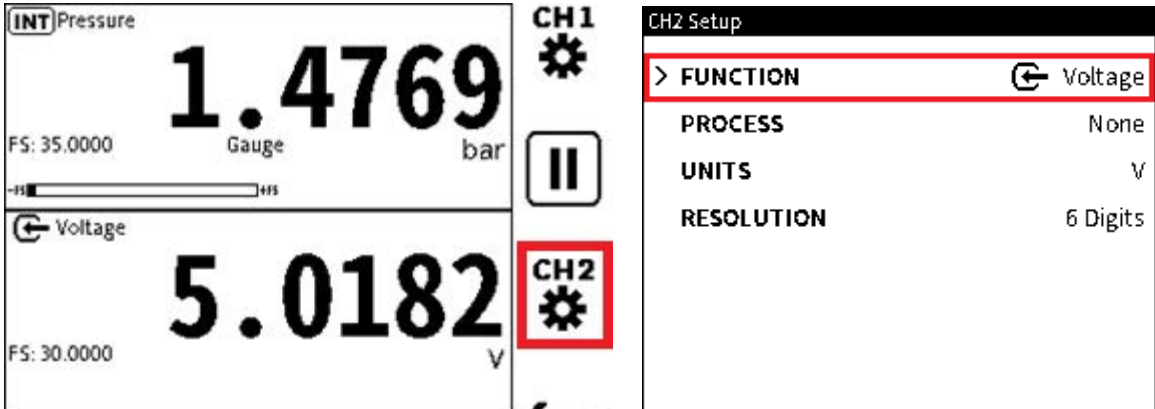

2. Select the **CH2** channel.
3. Select **FUNCTION** from the **Channel Setup** menu.

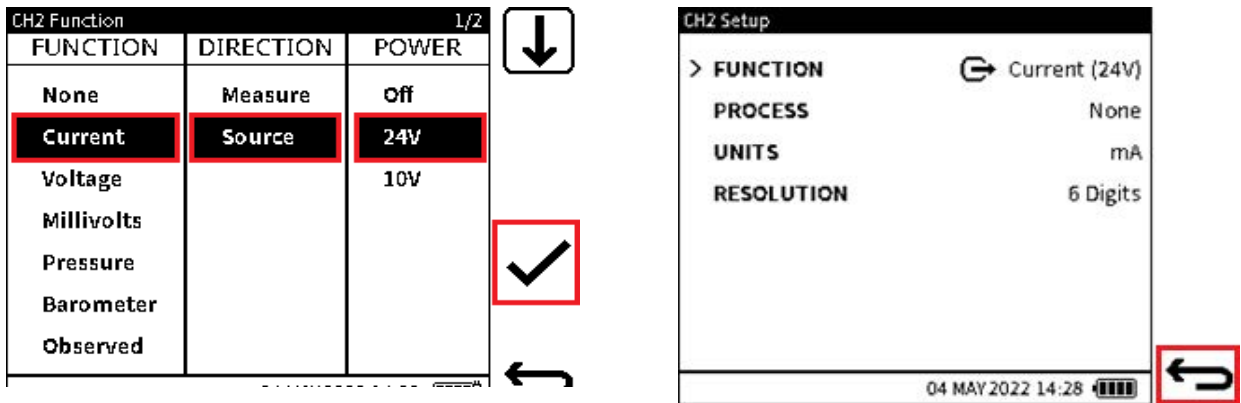

4. Select **Current** > **Source** > then select one of the following:
10 V to measure with the internal 10 V Loop Power supply
OR
24 V to measure with the internal 24 V Loop Power supply.

Select **✓** to make the selection.

If **Off** is selected, the electrical connections will be different to those for when **24 V** or **10 V** is selected (see Step 1).

The screen to the right will have only **Current** as the Function when **Off** is selected.

When **24 V** is selected, the screen will show **Current (24 V)**.

When **10 V** is selected, the screen will show **Current (10 V)**.

Select the **Back** **↩** icon to go to the **Calibrator Main** screen

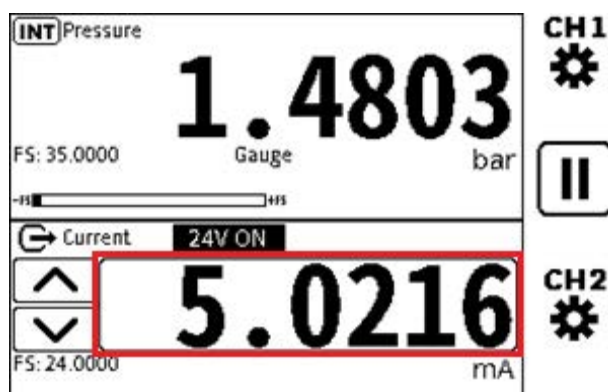

The DPI610E can supply electrical current accurately within the 0 to 24 mA range.

You can directly input the current value to be sourced using the Touchscreen or the Navigation Pad:

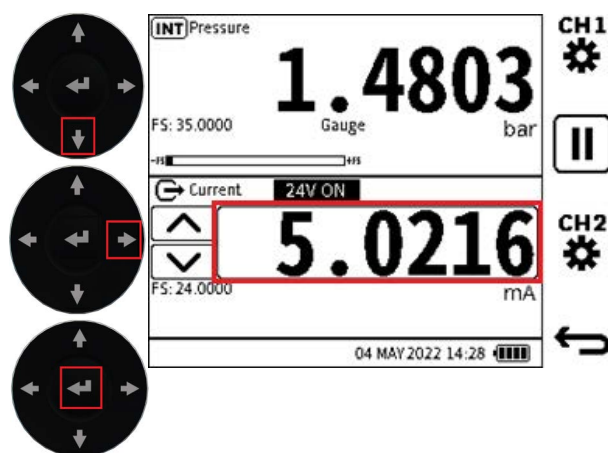

To use the Touchscreen, tap in the Current Value field. Use the UP/DOWN arrow icons on the left of the field to enter the current source value.



To use the Navigation Pad, push the DOWN button to select the CH2 window area. Push the RIGHT button until the source value is highlighted in bold. Push the OK  (Enter) button to show the source value entry screen. Enter the new value using the on-screen keyboard, and push the Tick  Softkey to make the selection.

i **INFORMATION** When a target current source value is set, the shown value will start to flash on the primary screen. When the setpoint is reached, the source value becomes stable.

6.3.10 Current Source Automation Options

The other methods to set the Current source output are:

1. Nudge (manual)
2. Span Check (manual or automated)
3. Percent Step (manual or automated)
4. Defined Step (manual or automated)
5. Ramp (automated)

Use the **Current Source** function to make these options available.

6.3.10.1 To get to the Current Source Automation Options

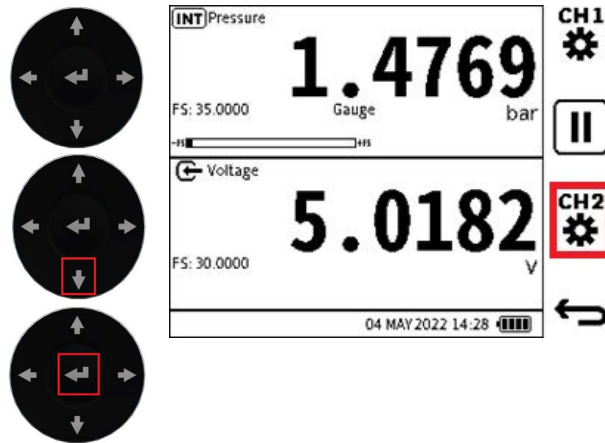

1. Tap on the **CH2** window (but not in the Units area) to maximize the **CH2** window. An alternative method is to use the Navigation Pad: push the **DOWN** button to select **CH2**, then tap the **OK** button to maximize the channel window.

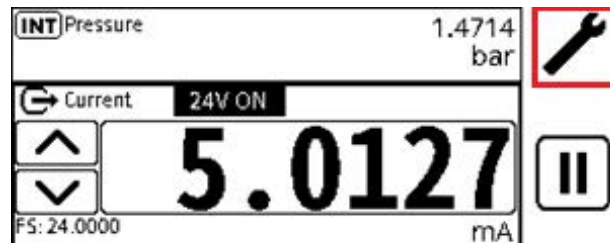

2. Select the **Setup** options  icon to show the **Source Automation** screen.

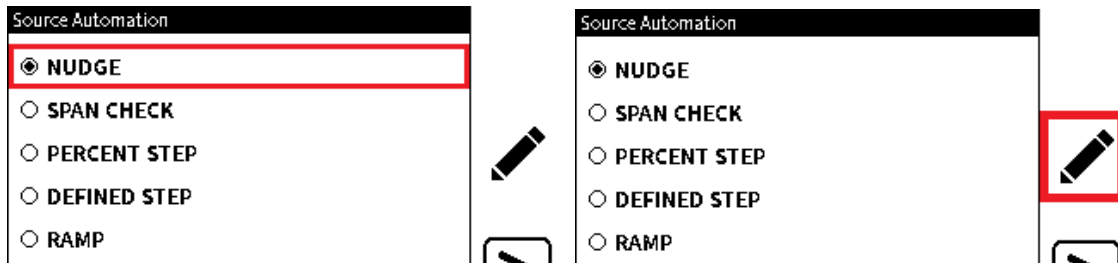

3. Select the option from the **Source Automation** screen. The usual option is **NUDGE**.
4. If necessary, select the **Edit**  Softkey and then set the parameters for the selected automation.

Note: Different automation options will have different parameters.

6.3.11 NUDGE

This is the **Source Automation** option that is automatically selected. It lets the source value be increased or decreased by a set step size value.

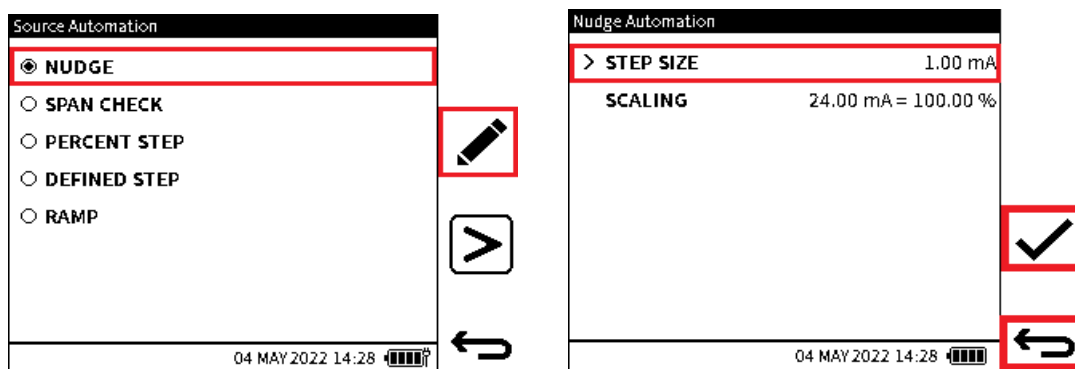

1. Select the **NUDGE** option. Tap the **Edit** Softkey to show the **Nudge Automation** menu. The display will show the **Nudge Automation** settings. Go to Step 2 to change the settings if necessary.
2. To change the step size, select **STEP SIZE** to show an on-screen keypad. Use the Touchscreen or Navigation Pad to enter the new value. For a description of **SCALING** refer to Section 6.4.6 on page 90. Select the **Tick** icon or Softkey to save the new values or the **Back** icon if the new values are not to be saved. Select the **Proceed** Softkey to use the selected automation option and its automation settings.

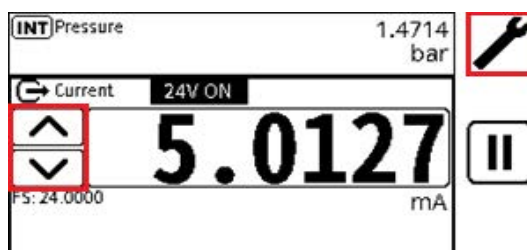

3. **Nudge Automation:** If using the Navigation Pad, push the **DOWN** button to select the **CH2** window and the **Enter** button to maximize the window. Push the **RIGHT** Navigation Pad button to make available the **UP/DOWN** buttons. If necessary, tap the **UP** or **Down** screen buttons to increase or decrease the Current value. Tap the **Setup** icon to show the **Source Automation** menu.

6.3.12 SPAN CHECK

Use this to examine the span of a device under test. Set the minimum current output that relates to the device's zero or negative full-scale. Also set the maximum current output that relates to the positive full-scale of the device under test. For most Current output devices, the minimum and maximum values are 4 and 20 mA. These are the values automatically used for the Span Check automation.

The **SPAN CHECK** function gives a 2-point span check. **LOW** (minimum) and **HIGH** (maximum) span values can be set. The **DWELL** time is the interval to wait at each Span Point before the change to the other span point.

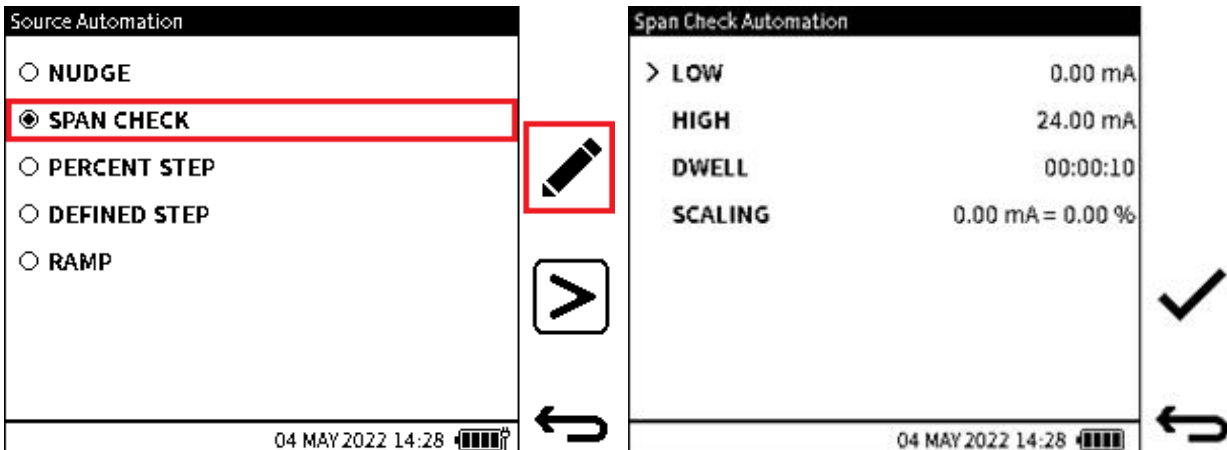

Chapter 6. Calibrator Tasks

6.3.12.1 To change the LOW or HIGH span values or the DWELL time:





1. Tap the **SPAN CHECK** option on the **Source Automation** screen to show the **Span Check Automation** screen. Tap the **Edit**  Softkey to show the **Span Check Automation** screen that has the **Span Check** settings. Go to Step 2 to change the settings if necessary.
2. The settings include
 - **LOW** value - this is the first current source value to be set.
 - **HIGH** value - this is the maximum current source value setpoint set.
 - **DWELL** - this is the time period to wait at the low value, before a change to the high value (or from a high value down to a low value.)
 - **SCALING** - refer to Section 6.4.6 on page 90.

Select the parameter value to be changed and use the on-screen or Navigation Pad to enter the new value.



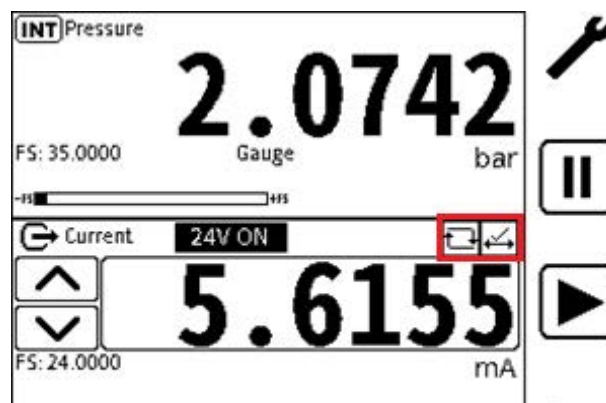

Select the **Tick**  icon/Softkey to save the new values or the **Back**  icon to not save the new values.

Select the **Proceed**  Softkey to use the automation option and its automation settings.







3. After selection of **Span Check** automation, the screen will show the **Span Check**  icon at the top right of the **CH2** window. The **Span Check** can be done manually. Use the **UP** and **DOWN** nudge buttons to switch between the **LOW** and **HIGH** source values. An option is available to automate the **Span Check**: tap the automation **Play**  Softkey.

If using the Navigation Pad:

- Push the **DOWN**  button to select the CH2 window and the **Enter**  button to maximize the window.
- Push the **RIGHT**  Navigation Pad button to make available the **UP/DOWN** buttons. If necessary tap the **UP**  or **DOWN**  screen keys to increase or decrease the Current value.

If using the Touchscreen:

- Tap on the Nudge **UP**  and Nudge **DOWN**  buttons to increase or decrease the Current value.
- The **Repeat**  icon is next to the **Span Check** automation  icon when the **Span Check** cycle is automatically repeated. This occurs when the automation **Play**  Softkey is used, until manually stopped.

To stop the automation immediately, tap the **Cancel**  Softkey.

6.3.13 PERCENT STEP

This function lets the source value be increased in steps that are related to a set percentage of the span. To set up and use the Percent Step automation:

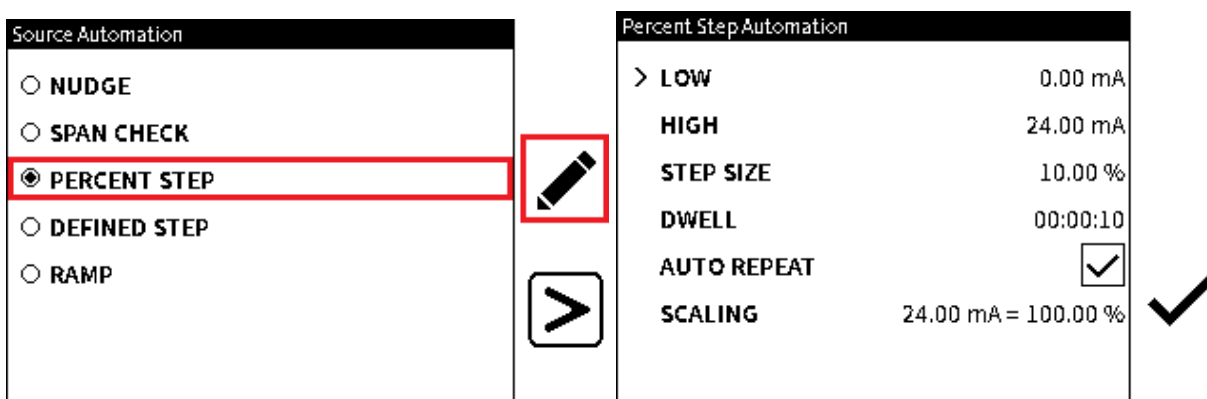

1. Tap the **PERCENT STEP** option on the **Source Automation** screen. Tap the **Edit**  Softkey to show the **Percent Step Automation** screen. Go to Step 2 to change the settings if necessary.
2. The setting includes:
 - **LOW** value - this is the first current source value to be set.
 - **HIGH** value - this is the maximum current source value setpoint set.
 - **STEP SIZE** - this is the value for each step increase or decrease. This option shows the Step Size as a percentage. The calculated mA step size will be related to the step size percentage of the **LOW** and **HIGH** value.
 - **DWELL** - the time interval that can be set for the wait period at each setpoint value, before the change to the next value.
 - **AUTO-REPEAT** - this tick box option lets the automation cycle be repeated continuously until manually stopped.
 - **SCALING** - Refer to Section 6.4.6 on page 90.





Chapter 6. Calibrator Tasks

Select the parameter value to be changed and enter the new value using the on-screen or Navigator keys.

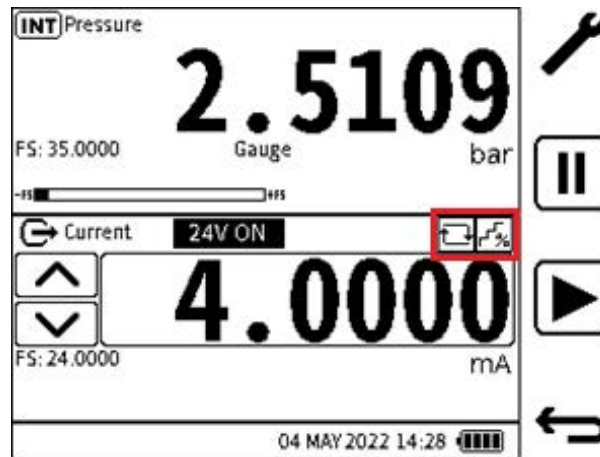



Select the **Tick** ✓ icon/Softkey to save the new values or the **Back** ↩ icon to not save the new values.

Select the **Proceed** > Softkey to use the selected automation option and its automation settings.







- When the **Percent Step**  function is selected, the display shows the **Percent Step** icon in the top right corner of the **CH2** window in the calibrator screen. The **Percent Step** sequence can be done manually: use the **UP**  and **DOWN**  nudge buttons to increase or decrease the source values. An option is to tap the automation **Play**  Softkey to automate the process.

If using the Navigation Pad

- Push the **DOWN**  button to select the CH2 window and the **Enter**  button to maximize the window.
- Push the **RIGHT**  Navigation Pad button to make available the UP/DOWN buttons. If necessary tap the **UP**  or **DOWN**  screen keys to increase or decrease the Current value.

If using the Touchscreen

- Tap on the Nudge **UP**  and Nudge **DOWN**  buttons to increase or decrease the Current value.
- If the Auto-repeat function is selected its  icon will be next to the Percent Step automation  icon. The automation cycle is automatically repeated until manually stopped.

To stop the automation immediately, tap the **Cancel**  Softkey.

6.3.14 DEFINED STEP

The **DEFINED STEP** automation lets a defined step size within the span limits be set. The **LOW**, **HIGH** and **STEP SIZE** value set the span limits. There is the option to auto-repeat the automation process.

To set up and use the Defined Step automation:

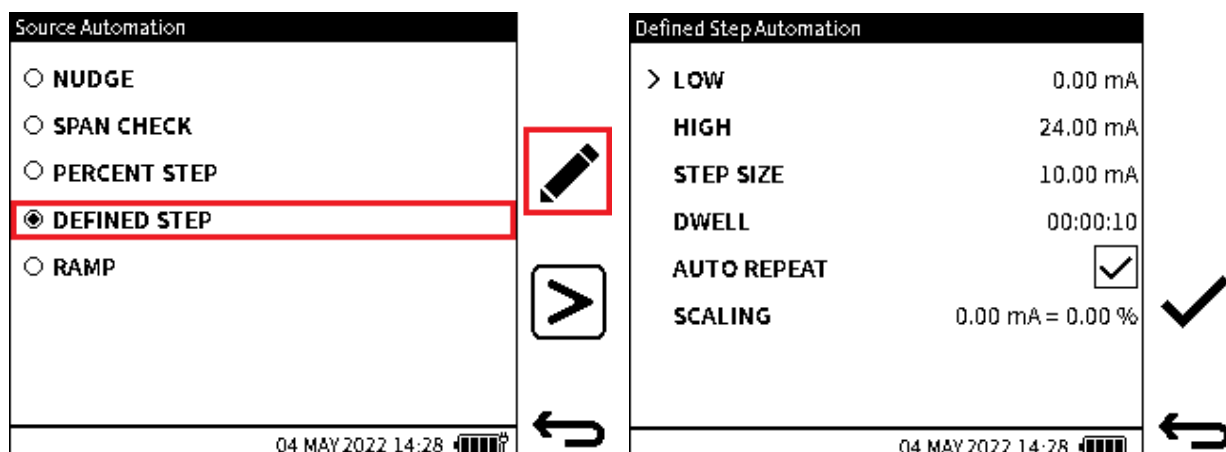



1. On the **Source Automation** screen tap the **DEFINED STEP** option to show the **Defined Step Automation** screen. If you want to view or edit the **DEFINED STEP** automation settings, go to Step 2.
2. This setting includes:
 - **STEP SIZE** value - this is the value of each step increase or decrease. The values of this option are measured in mA.
 - **DWELL** - this is the time interval that can be set to pause or wait at each setpoint value before the change to the next value.
 - **AUTO-REPEAT** - this checkbox option lets the automation cycle repeat continuously until manually stopped.
 - **SCALING** - Refer to Section 6.4.6 on page 90.

Tap or select the parameter value to be changed. Use the Touchscreen or Navigator Pad buttons to enter the new value.

Select the **Tick** ✓ icon/Softkey to save the new values or the **Back** ↶ icon to not save the new values.

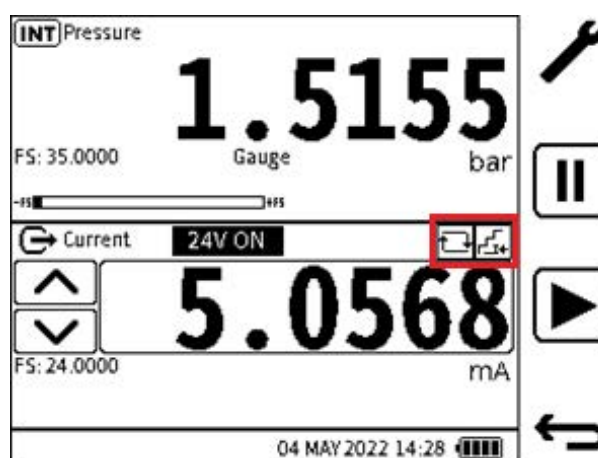

Select the **Proceed** > Softkey to use the selected automation option and its automation settings.



3. When the **Defined Step**  function is selected, the screen shows its icon in the top right of the **CH2** window in the Calibrator screen.

Chapter 6. Calibrator Tasks

The **Defined Step** sequence can be done manually. Use the **UP**  and **DOWN** nudge buttons, to increase and decrease the source values.

You can push the automation **Play**  Softkey to automate the process. If the **Auto-repeat** function is selected its  icon will be next to the **Defined Step**  icon. The automation cycle automatically repeats until manually stopped.

To stop the automation at any time, tap the **Cancel**  Softkey.

6.3.15 RAMP

The **RAMP** function lets the source value automatically change from a defined **START** value to a defined **END** value. This is done in a specified time: this time value can increase or decrease. The **TRAVEL** time can be set to define the time for the value to go from **START** to **END** or from **END** to **START**.

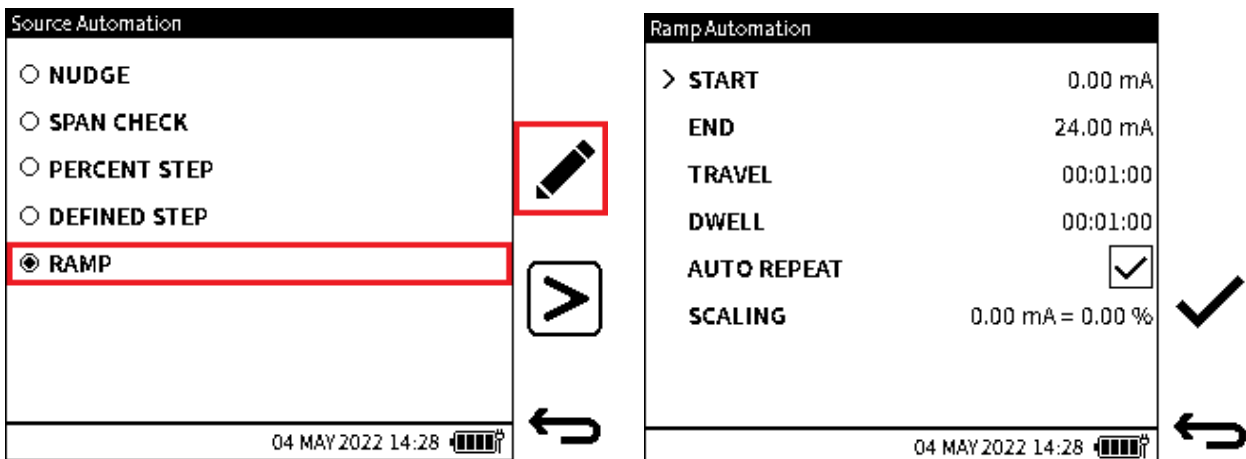

1. On the **Source Automation** screen tap the **RAMP** option. Select the Edit  Softkey to show the **Ramp Automation** menu screen.
2. This setting includes:
 - **START** value - this is the first Current source value to be set.
 - **END** value - this is the maximum set-point of the Current source value.
 - **TRAVEL** - this is the time for the Current source value to Change (ramp) from the **START** value to the **END** value. This automatically calculates the step size to be used, to agree with the travel time.
 - **DWELL** - this is the time that can be set to temporarily stop at each setpoint value, at the end of each direction or travel, before a change to the opposite direction of travel.
 - **AUTO-REPEAT** - the checkbox option that lets the automation cycle be repeated continuously until manually stopped.
 - **SCALING** - refer to Section 6.4.6 on page 90.

Tap or select the parameter value to be changed. Use the Touchscreen or Navigation Pad to change the value.

Select the **Tick** icon  to set the new values.

Select the **Proceed**  icon to operate the option and go back to the **Calibrator** screen.

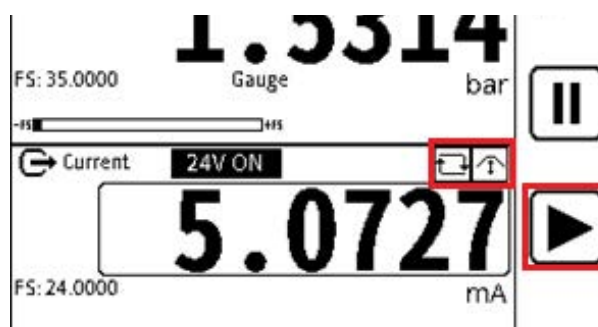

3. The **Calibrator** screen will show the **Ramp** and the **Repeat** icon (if selected). The **Ramp** sequence is not manually controlled. So the **UP** and **DOWN** nudge buttons are not usable with this option. Push the **Play** Softkey to select automation. The automation cycle continuously repeats until manually stopped. To stop the automation immediately, push the **Cancel** Softkey.

6.3.16 Voltage

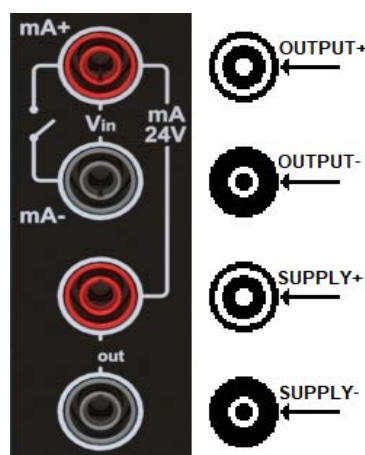

For the DPI610E instrument, voltage is measured in Volts (V) or millivolts (mV) and is a function of **CH2** only. When the **Voltage** function is selected, the **Direction** is automatically set to **Measure** (because the DPI610E does not make available the **Source** option.) The voltage value can be from -30 V to 30 V.

Using the **Voltage** function makes available the option to use the internal 10 V or 24 V power supply from the DPI610E. The measurement of the voltage input from an external power source, is also available.

The diagram shows terminal connections for measurement of voltage.

Chapter 6. Calibrator Tasks

6.3.16.1 Voltage Measure - Setup

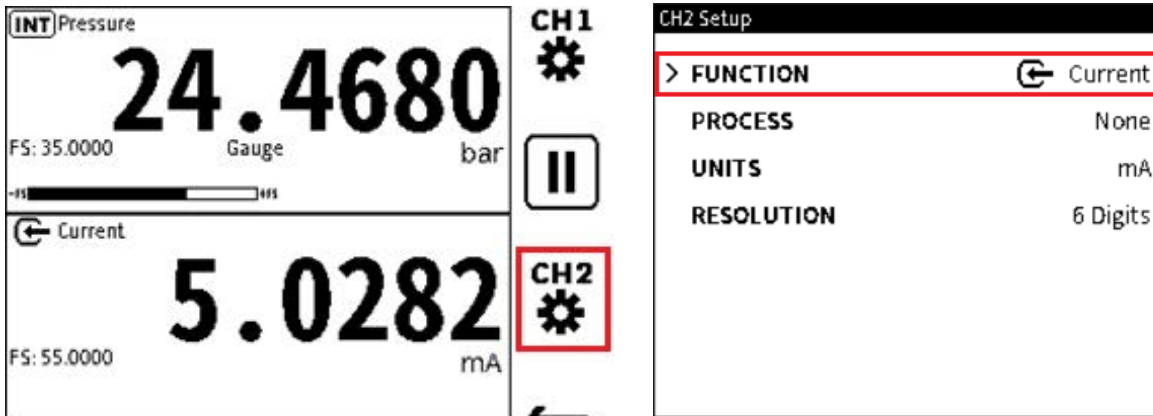

1. From the **Calibrator** screen, select the channel 2 ^{CH2} **Setup** screen (either tap the screen icon or push the Softkey.)
2. Select **FUNCTION** from the **CH2 Setup** screen.

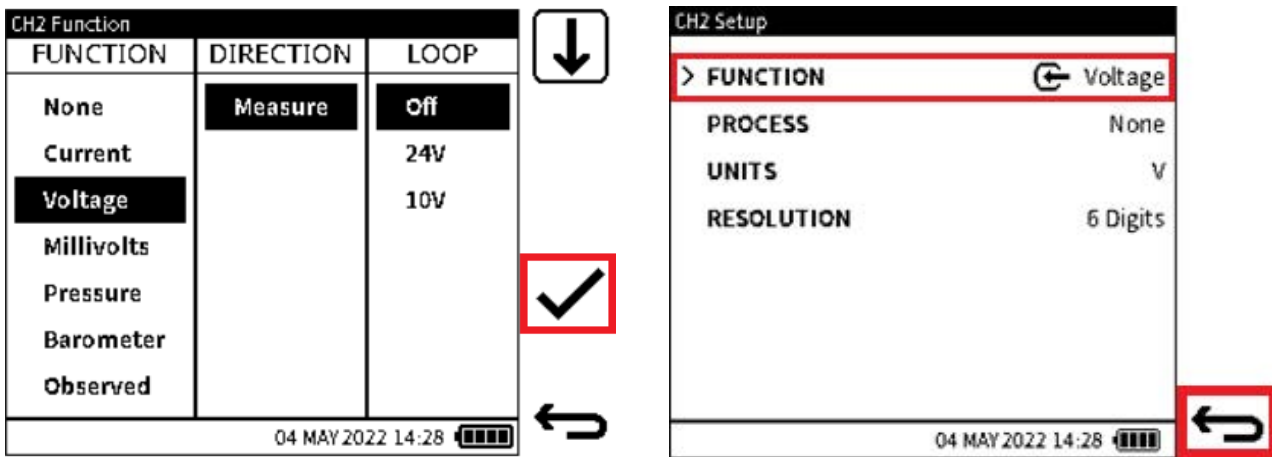

3. Select **Voltage > Measure** then select one of the following:
 - **Off** for measurement without internal loop power supply
OR
 - **24 V** for measurement with internal 24 V loop power supply
OR
 - **10 V** for measurement with internal 10 V loop power supply.

Select the **Tick** ✓ icon to make the selection and set the instrument. Make sure that the **Voltage** mode is active.

Select the **Back** ↶ icon to show the **Calibration** screen.



4. Make sure that the screen shows **Voltage**.

6.3.17 Millivolts Measure - Setup

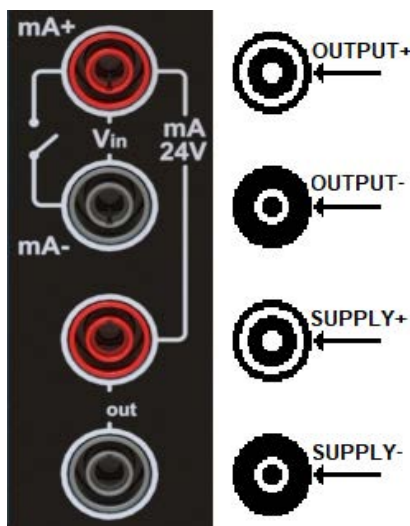

Voltage can also be measured in millivolts (mV) and is a function of CH2 only. When the **Millivolts** function is selected, the **Direction** is automatically set to **Measure**. The **Source** option is not available.

The available millivolts range is -2000 mV to 2000 mV. Using the **Millivolts** function gives an added option to use the DPI610E internal 10 V or 24 V power supply or to measure the millivolts input from an external power source.

The diagram shows terminal connections for measurement of millivolts.

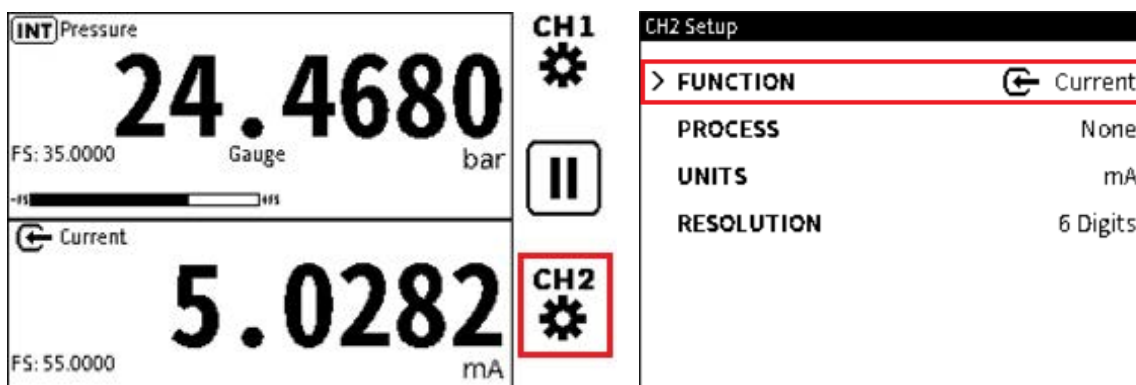

Chapter 6. Calibrator Tasks

- From the **Calibrator** screen, select the Channel 2  **Setup** (either tap the screen icon or push the Softkey).
- Select **FUNCTION** from the **CH2** setup screen.

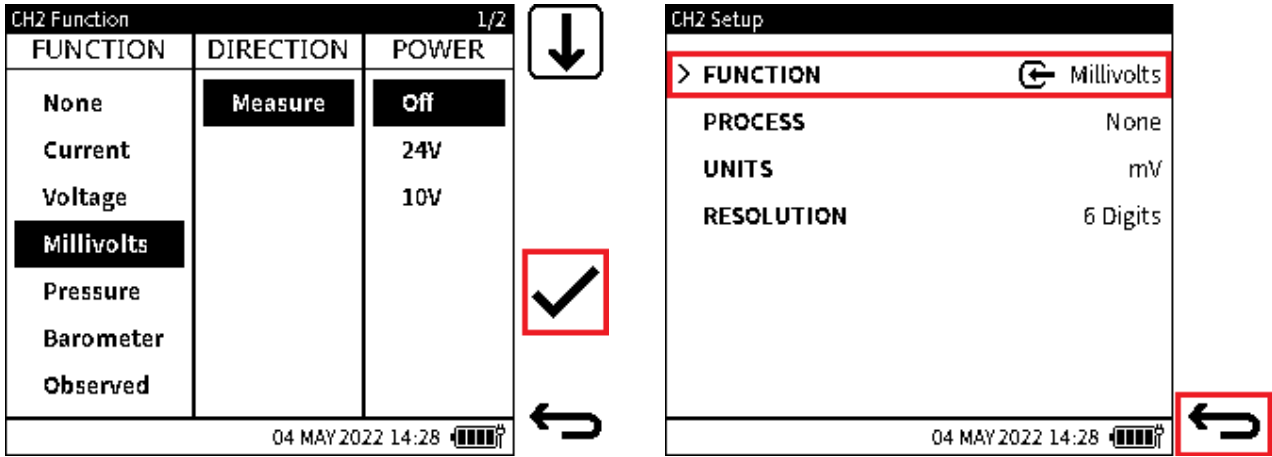

- Select **Millivolts** > **Measure** then select one of the following:
 - Off** for measurement without internal loop power supply
OR
 - 24 V** for measure with internal 24 V loop power supply
OR
 - 10 V** for measure with internal 10 V loop power supply.

Select the **Tick**  icon to make the selection and set the instrument. Make sure that the **Millivolts** mode is selected.

Select the **Back**  icon to show the **Calibrator** screen.

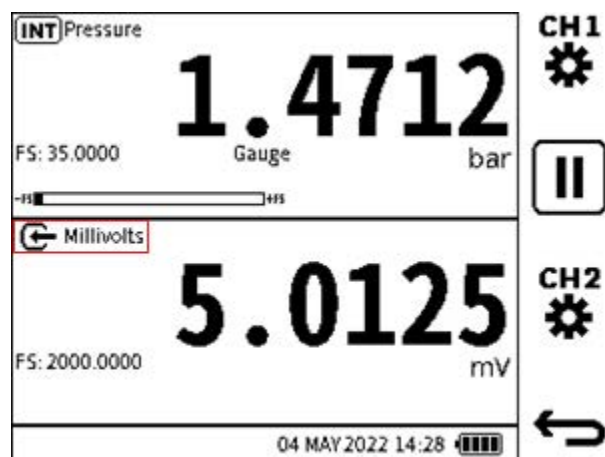

- Make sure that the screen shows **Millivolts**.

6.3.18 HART

The DPI610E can use the **HART** (Highway Addressable Remote Transducer) communication protocol. Basic HART operation and setup on HART supported devices can be done. The HART bi-directional communications technology operates as a master/slave protocol. When the

DPI610E connects to the HART device, the DPI610E operates as the master and the HART device as the slave. The DPI610E uses functions from the Universal and Common Practice commands specified in HART revision 5, 6 and 7 (see more about HART in Chapter 13 on page 211).

The HART function is only available on **CH2**. It uses the current loop signal for its communication. This lets the DPI610E supply 10 V/24 V loop power supply to the HART device if necessary.

The DPI610E also offers an optional 250 ohm resistor that gives the voltage drop necessary for the HART communication when you do not have an external HART resistor.

Energize and de-energize The HART resistor using the **CH2 Setup** window.

To select the **HART** function:

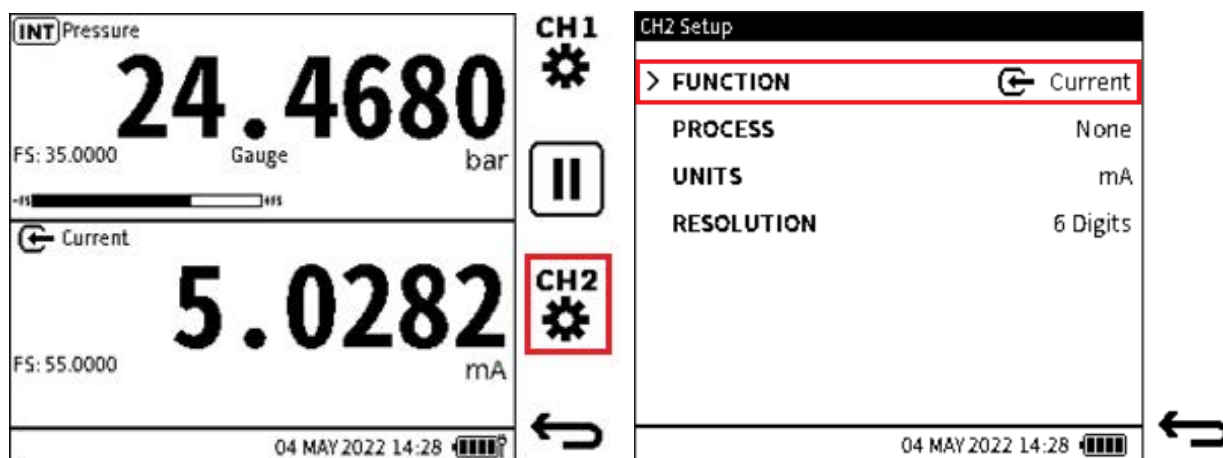



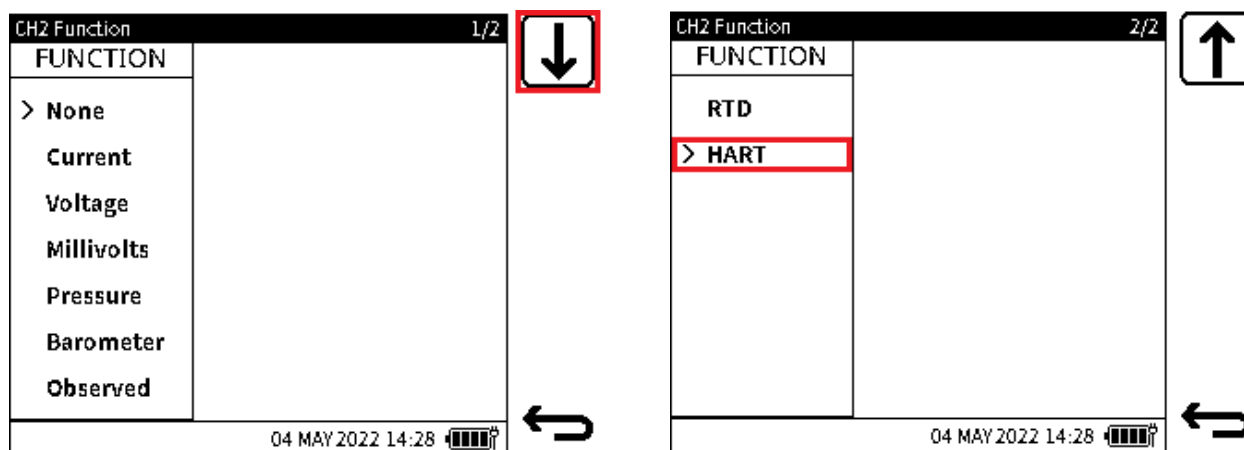

1. From the Calibrator screen, select the channel 2 **CH2 Setup** icon (either tap the screen icon or push the Softkey).
2. Select **FUNCTION** from the **CH2 Setup** screen.



3. Select **None** in the **FUNCTION** column and tap the page down Softkey to look at the second page of **CH2** functions.
Tap **HART** on the second screen to see two more selection columns.

CH2 Function 2/2		
FUNCTION	DIRECTION	POWER
RTD	Measure	Off
HART	Master	24V

4. Select the necessary options in the columns and then select the **Tick**  icon to make the selection and instrument setup.

The screen shows the **CH2 Setup (HART)** setup screen. Make more selections on this screen or select the **Back** icon to show the **Calibration Main** screen.

For more information on how to do the setup of the **HART** application and the **HART** device, see Chapter 13 on page 211.

To cancel the **HART** function, to enable the selection of another function, use the procedure in Section 13.2 on page 214 to go back to the **Configuration** screen.

6.4 Process Options

6.4.1 Tare

Use the Tare function to set the channel readings to a temporary zero. When you use the Tare function, the primary reading value is deducted from new reading values until Tare is disabled. The initial reading will be approximately zero. Thus the use of the Tare function makes clear the differences in new measured values.

For example, if the reading from the internal pressure sensor is 21.4985 bar at the time Tare is selected, the reading becomes approximately 0.000. This is because when the value 21.4985 is sensed, it is subtracted from true reading, and the resulting value is then shown. When Tare operates, the display will show the Tare symbol  in the related channel window.

Note: Tare is only available for most **Measure** functions but not for **Barometer** and **HART**.

To select the Tare function:

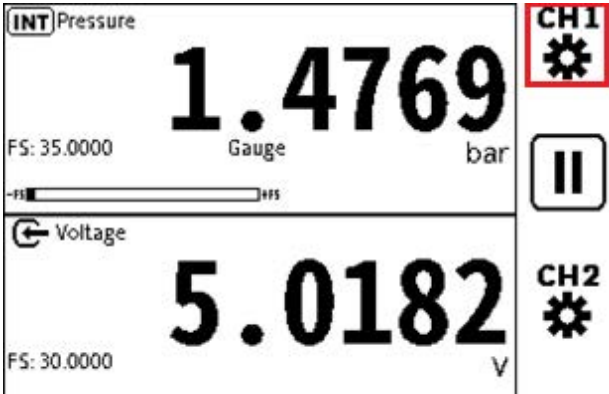

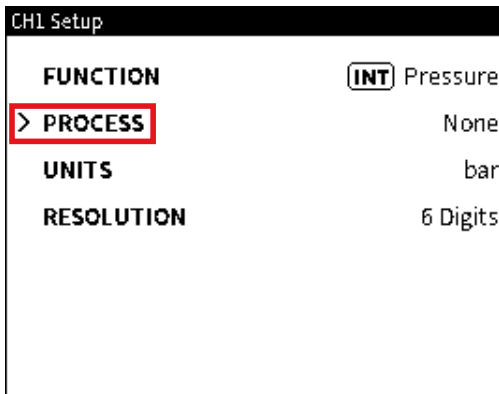

1. Select the wanted channel.
2. Select **PROCESS**.

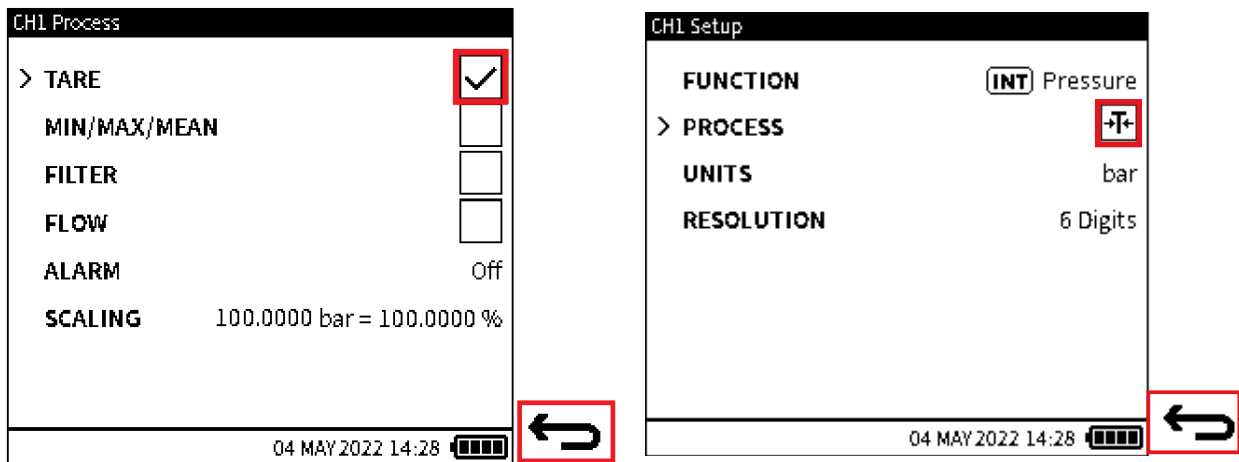

3. Select the **TARE** Checkbox. Tap on the checkbox or use the Navigation Pad buttons to move to the **TARE** row and push the Pad's **Enter** button. Select the **Back** icon to go back to the **Channel Setup** screen.
4. Make sure that the **TARE** icon is in the **CH Setup** screen. **Tare** is in operation when the screen shows this icon.
Select the **Back** icon.

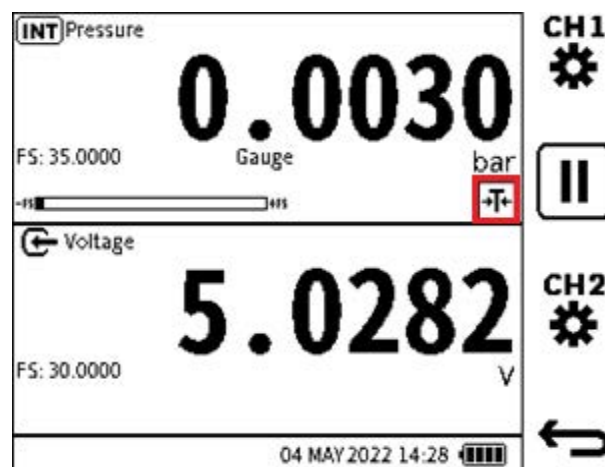

5. Make sure that the screen has the **TARE** icon in the related channel window and the channel reading is zero or near to zero.



INFORMATION When Tare is not in operation, the primary reading shows only the true measured value.

6.4.2 Min/Max/Mean

This function gives the minimum, maximum and average of the primary reading from the time the functions start to operate. Its value is continuously shown as the reading values change, in addition to the live primary reading. When the function is on, the screen shows the

Chapter 6. Calibrator Tasks

Min/Max/Mean status  icon. Maximize the related channel to see the added information (refer to “Maximize and Minimize Channel Window - Using the Touchscreen” on page 48 for how to maximize the window).



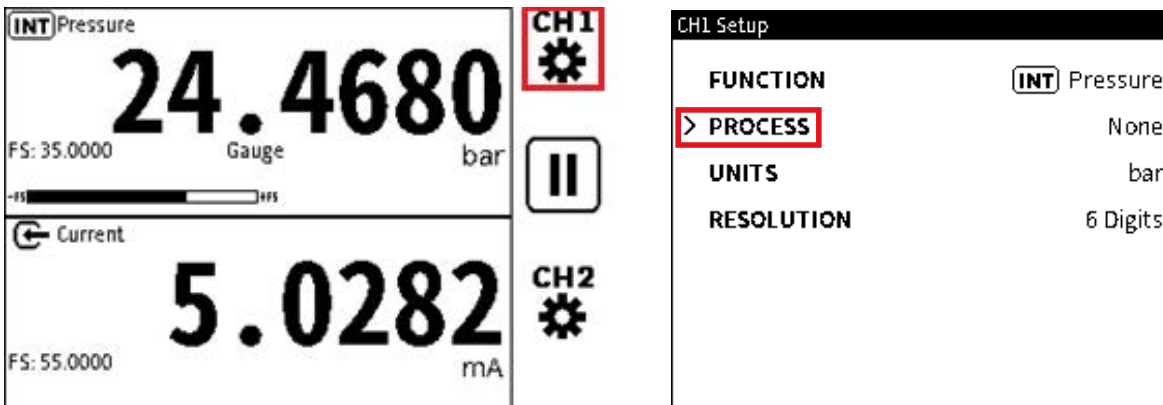

INFORMATION The **Min/Max/Mean** function relates to most **Measure** functions but not **HART**.

To enable the **Min/Max/Mean** function:

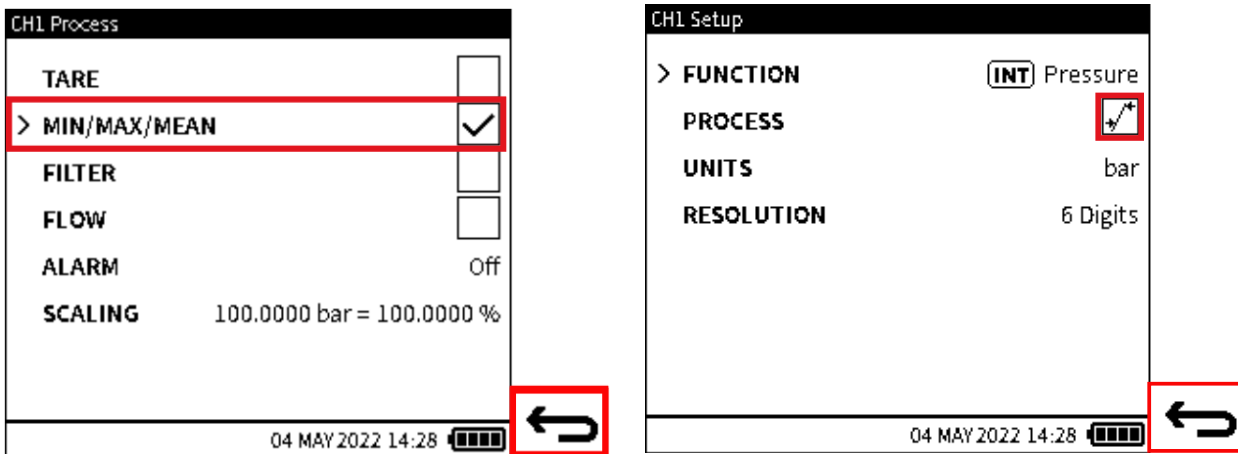

1. Select the wanted channel.
2. Select **PROCESS**.



3. Select the **MIN/MAX/MEAN** checkbox and then select the **Back** icon.
4. Make sure that the screen shows the **Min/Max/Mean**  icon as the **PROCESS** option. This shows that the **Min/Max/Mean** is in operation in the **Channel Setup** screen.

Select the **Back**  icon.

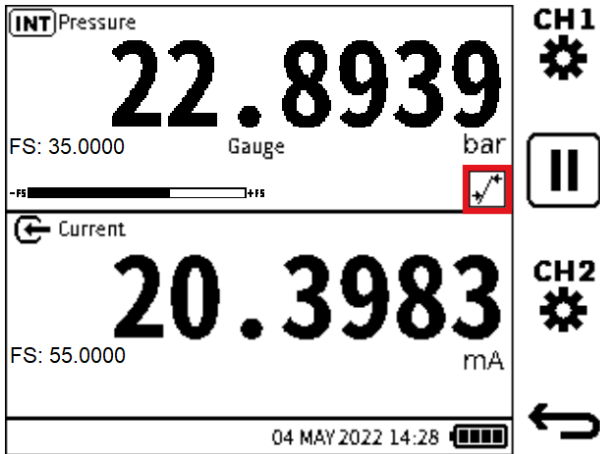

5. Make sure that screen shows the **Min/Max/Mean**  icon in the related channel window.



INFORMATION To see Min/Max/Mean information, maximize the related channel window. See “Maximize and Minimize Channel Window - Using the Touchscreen” on page 48 for details.

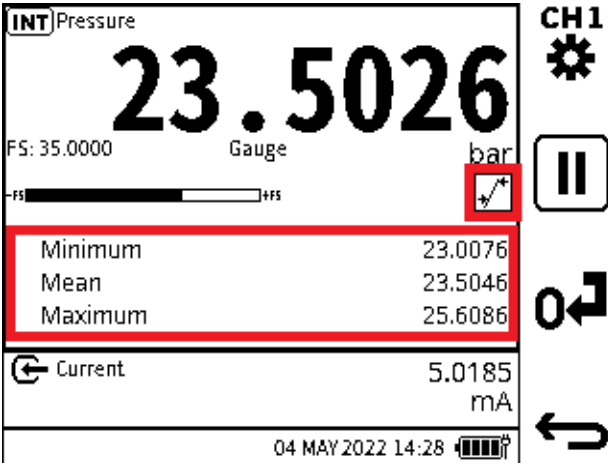

6. The display shows **Min/Max/Mean** information in the maximized channel window.

6.4.3 Filter

The **Filter** function lets a low pass band filter be used to supply channel readings. This filter gives a more stable measurement reading over a noisy signal.



INFORMATION The Filter function can be used on most functions but not HART.

When the **Filter** process option is on, the screen shows the **Filter** status icon in the related channel.

To make available the **Filter** function:

Chapter 6. Calibrator Tasks

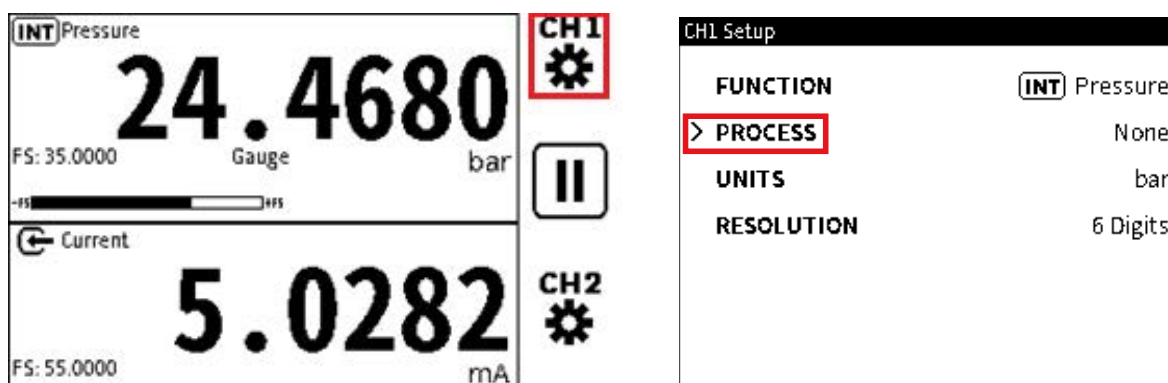

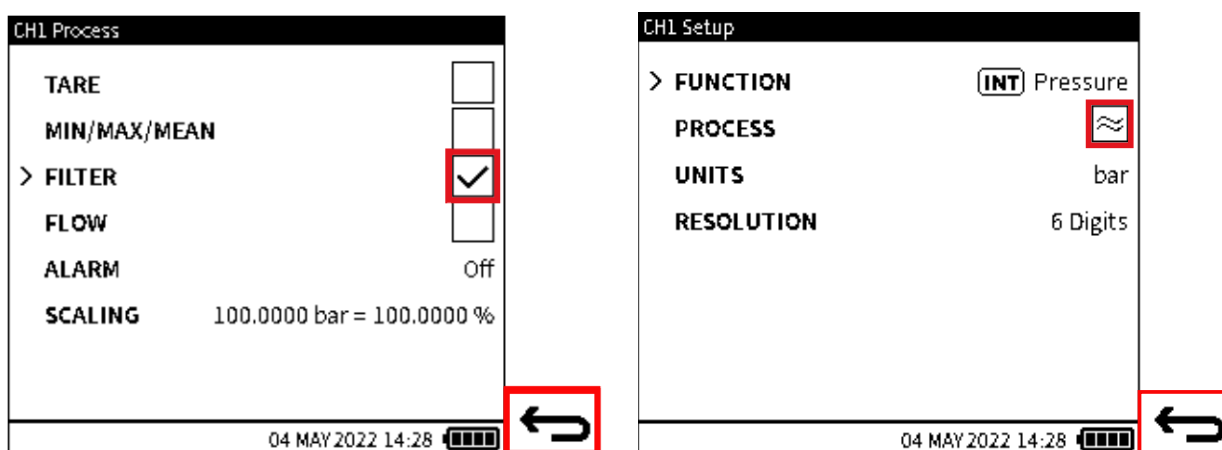

1. Select the wanted channel.
2. Select **PROCESS**.

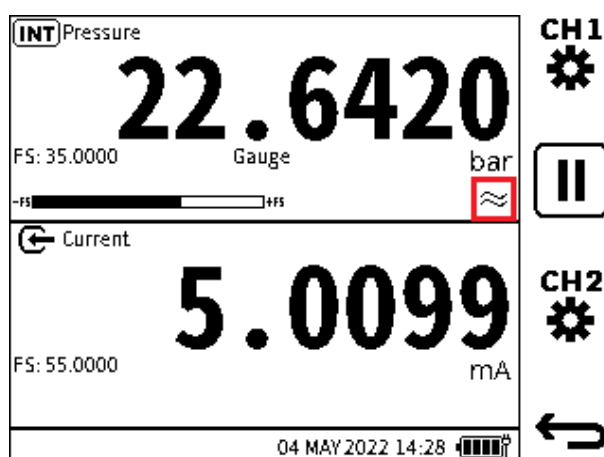

3. Tap the **FILTER** checkbox (put a tick mark in it) and then select the **Back** ↩ icon.
4. The screen shows the **FILTER**  icon in the **PROCESS** row. This shows that **FILTER** is on in the **Channel Setup** menu (as the **PROCESS** Option).

Select the **Back** ↩ icon to go back to the **Calibration Main** screen.



- 5. Make sure that the screen shows the **FILTER**  icon in the related channel window. (The **FILTER** icon will show the **PROCESS** option).

6.4.4 Flow

The **Flow** function lets the square root of the measured pressure value be shown as the primary reading.



INFORMATION The Flow process option is only used by pressure functions (Internal Pressure, External Pressure, Sum and Difference).

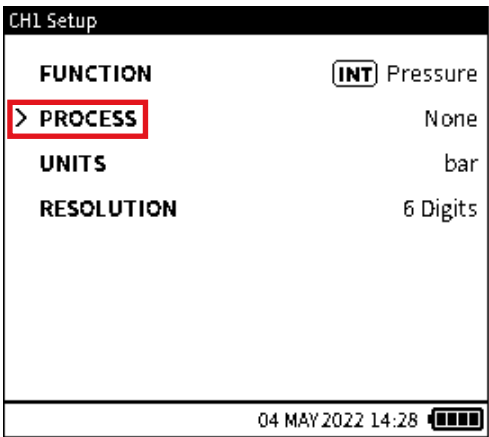
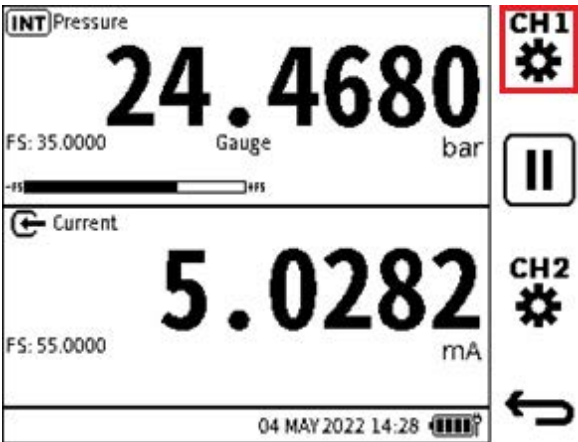

The screen shows the **Flow** status icon  when this process option is in operation.

To use the **Flow** function:

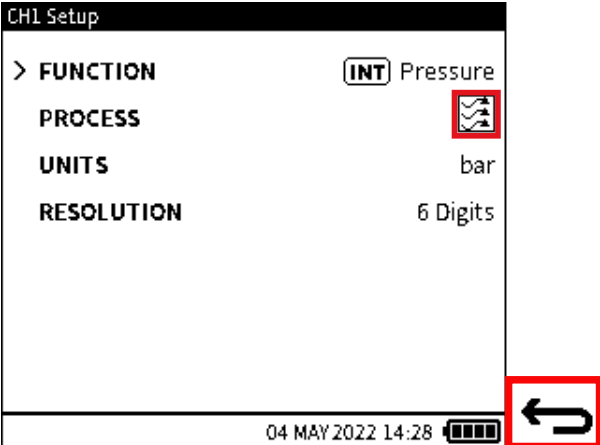
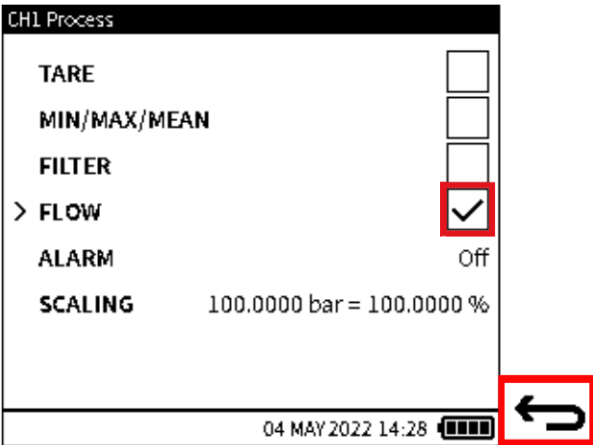

- 1. Select the wanted channel.
- 2. Select **PROCESS**.



- 3. Tap the **FLOW** checkbox (put a tick mark in it) and then select the **Back**  icon.
- 4. The screen will show the **FLOW**  icon in the **PROCESS** row. This shows that **FLOW** is in operation in the **Channel Setup** menu (as the **PROCESS** Option.)
Select the **Back** icon to go back to the **Calibration Main** screen.

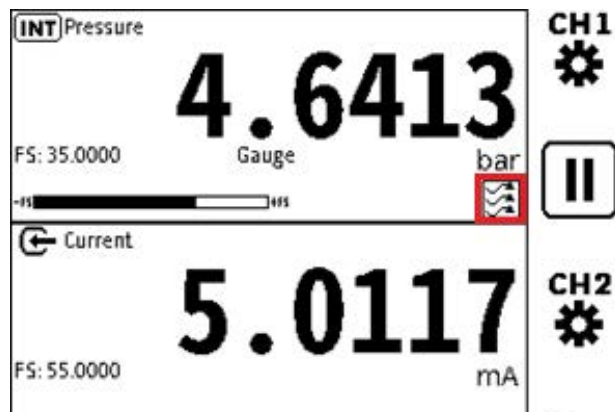

5. Make sure that the screen shows the **FLOW**  icon in the related channel window.

6.4.5 Alarm



This process option gives a visual indication of when a user-set alarm operates.

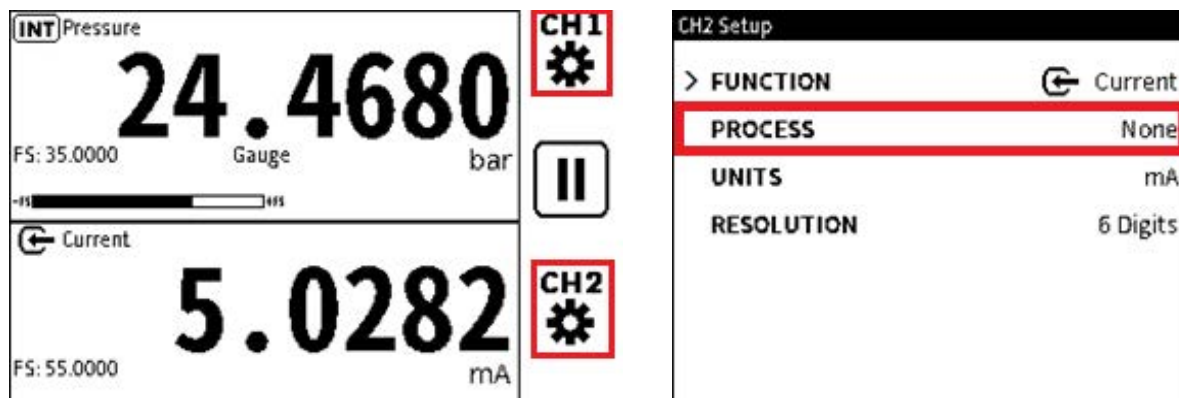

INFORMATION The user Alarm option is available with all Measure functions except for Barometer and HART.

To select and do the setup of the user Alarm option:



1. Select the ^{CH1}  or ^{CH2}  icon as the wanted channel.
2. Select **PROCESS**.

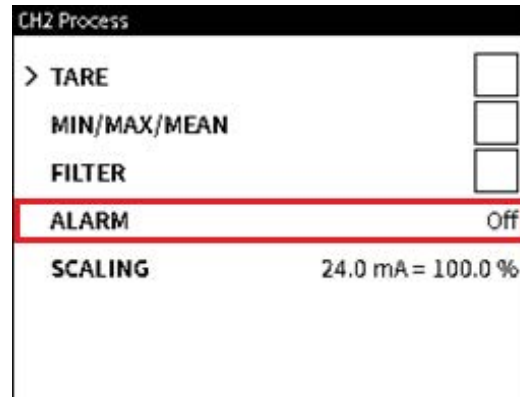

3. Tap in the **ALARM** area or use the Navigation Pad buttons to select the area. The display shows the **Alarm** screen.

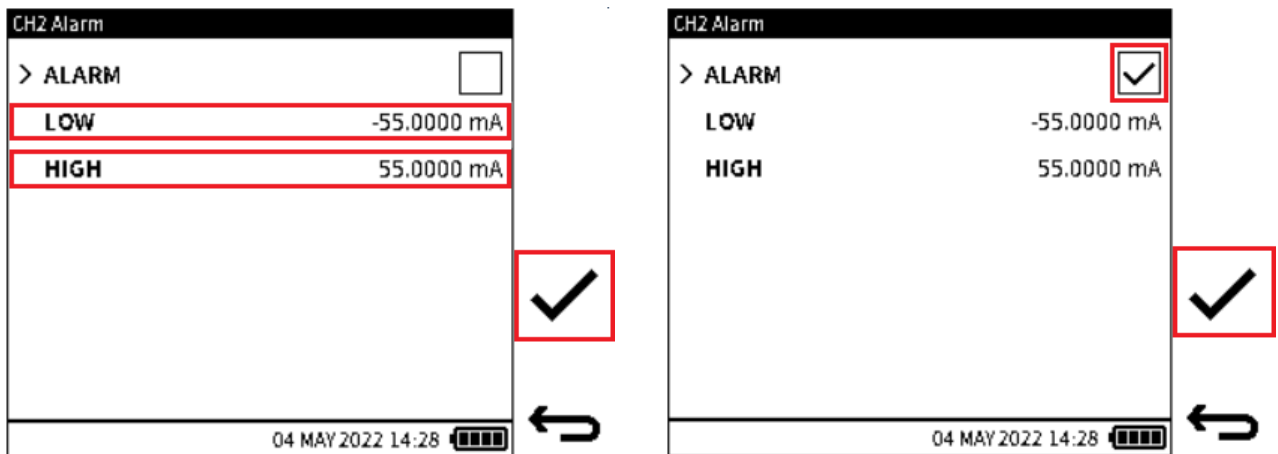

4. Use the procedures given below to set the **LOW** and **HIGH** values for when the alarm operates.

Use the Navigation Pad button to move to the **LOW** option, push the Navigation Pad **Enter**  button to show an on-screen keypad. Use the keypad to enter the value for the lower end of normal range condition. Select the **Tick** Softkey to confirm the value.

Note: The **LOW** (zero or negative full-scale) range value of the selected measure function, automatically has a value.

Select the **HIGH** option and enter the value for the highest end of normal range condition. Select the **Tick** Softkey to enter the value.

Note: The **HIGH** (positive full-scale) range value of the selected measure function, automatically has a value.

Use the Navigation Pad to select the **ALARM** row. Push the **Enter**  button in the pad to put a tick into its checkbox or tap in the empty checkbox. Push the **Tick** Softkey to set the alarm settings and go back to the **PROCESS** options screen.

Note: To cancel the Alarm, select the **ALARM** checkbox to remove the **Tick** mark.

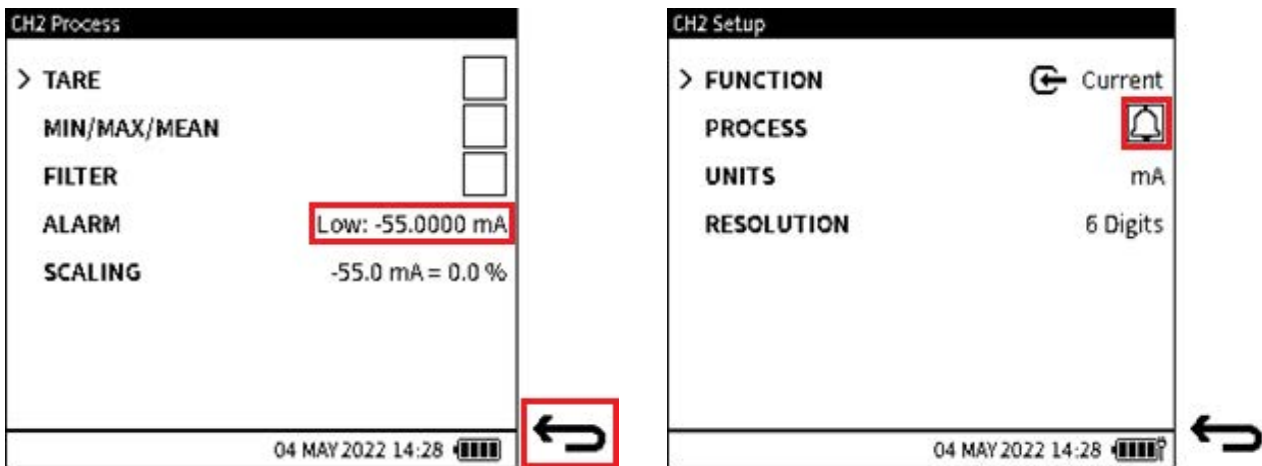

- The screen shows values in the **ALARM** row, that switch between the **LOW** and **HIGH** values.

Push the **Back** Softkey to go back to the **Channel Setup** screen.

The screen shows the **ALARM**  icon. This shows that the **PROCESS** option is on.

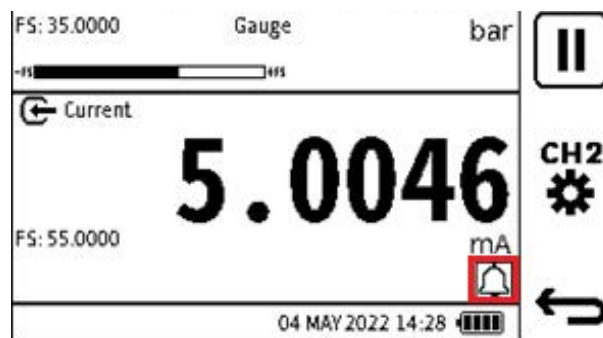

- The screen shows the **ALARM**  icon in the related channel window. This is after the Alarm becomes available for use.

If the measured value is outside the normal range condition, the alarm will operate.

An alarm condition is shown by both the **ALARM**  icon and the measured reading flashing in the related channel.

When the measured value is in the normal specified range condition, the icon and measured value will both stop flashing.

6.4.6 Scaling

This process option gives a method for the setup of special measurement units: this is done by the use of the original measurement units of the Functions. Scaling gives two pairs of values that show the linear relationship between the original measurement unit and the custom unit setup.





INFORMATION The Scaling option is available with most measure and source functions but not for Observed and HART.

The DPI610E has two methods to select and setup the Scaling.

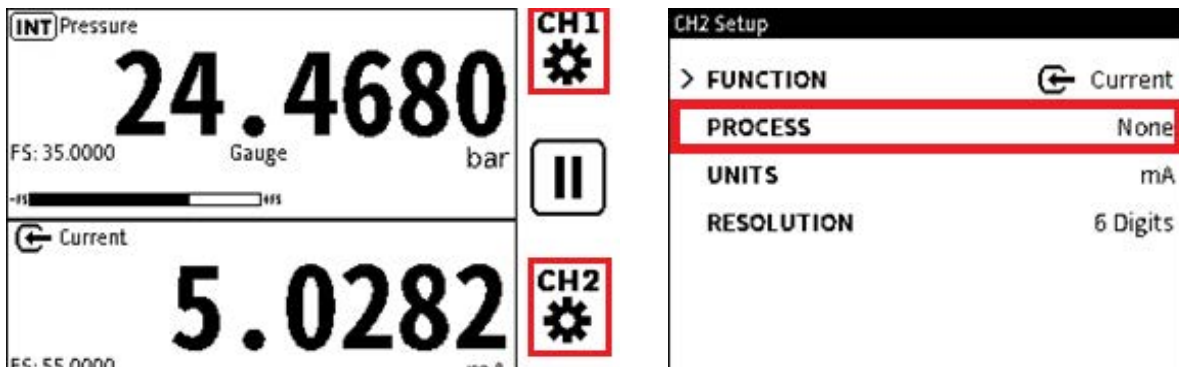

6.4.6.1 Scaling Method 1

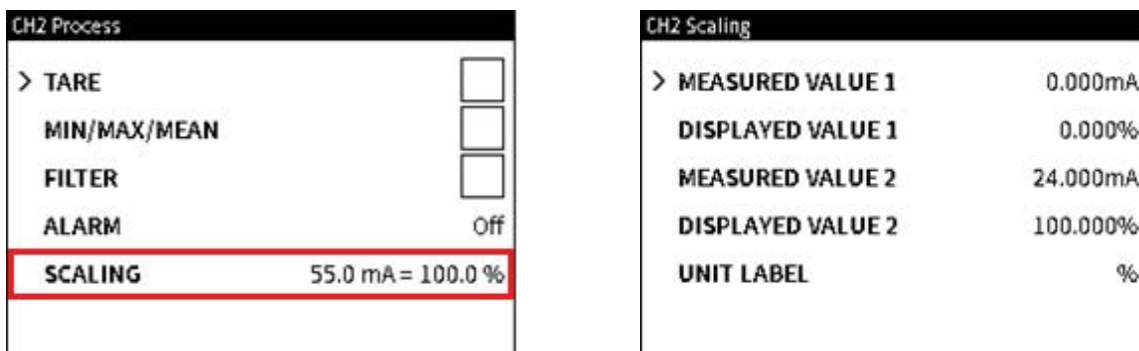

1. Select the ^{CH1}  or ^{CH2}  icon for the wanted channel.
2. Select **PROCESS**.



3. Tap the **SCALING** area or use the Navigation Pad buttons to select the area. The screen shows the **Scaling** screen for the selected channel.

4. Use the buttons on the Navigation Pad to move to the related row and push the **Enter**  button to show a screen keypad. Tap or use the Navigation Pad buttons (push the **Enter**  button to enter each number) to select each keypad number. To set the full number, push the **Tick Softkey**.

- **MEASURED VALUE 1** - a minimum value in the measurement/source range of the selected function. This value field is automatically filled with the zero or negative full-scale value of the measurement/source function.
- **DISPLAYED VALUE 1** - a minimum value equivalent to the minimum measured value shown as the custom unit. This option is automatically given the value of 0 (%).
- **MEASURED VALUE 2** - a maximum value in the measurement/source range of the selected function. This option is automatically given the positive full-scale value of the measurement/source function.
- **DISPLAYED VALUE 2** - a maximum value equivalent to the maximum measured value shown as the custom unit. This option is automatically given the value of 100 (%).
- **UNIT LABEL** - a free text field where the special unit can be named. It is limited to a maximum of six characters. This special unit is automatically given the value of '%'. 

Chapter 6. Calibrator Tasks

The custom label uses this relationship formula:

$$DV_x = ((DV_2 - DV_1)/(MV_2 - MV_1)) \times MV_x$$

Where DV = Displayed Value and MV = Measured Value

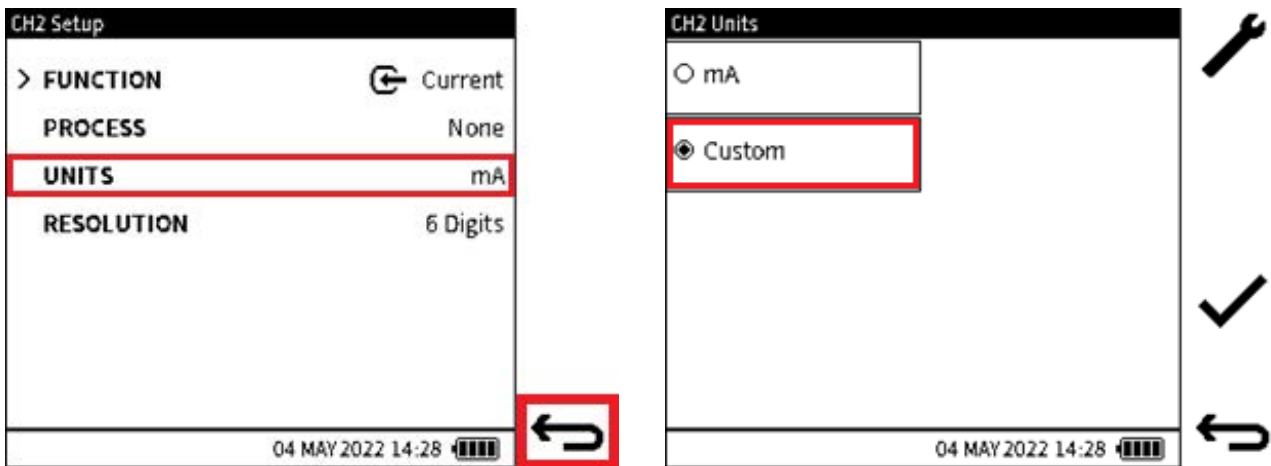

Note: The measured values are in the original units e.g. mA and screen values are in the special label units e.g. '%'.
When the scaling parameters have been set, select the **Tick** Softkey to make the changes and go back to the **PROCESS** screen. The changed **Channel Scaling** parameters are shown in the **Scaling** fields.

5. Tap the **Back** button in the **Channel Process** screen to show the **Channel Setup** screen.

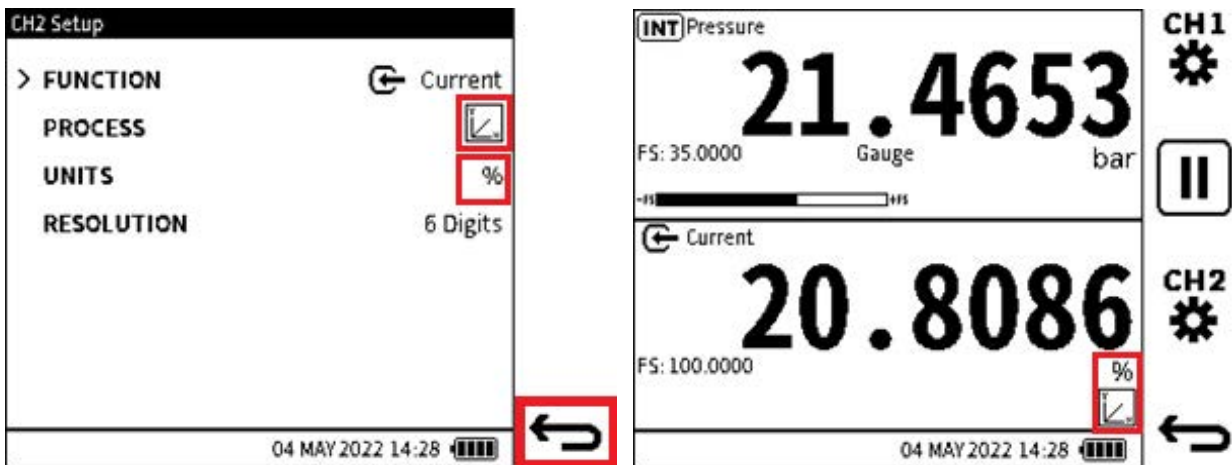

6. To make available or use the custom units, select **UNITS** to show the channel **Units** screen, then tap or select the **Custom** option.
Select the **Tick** Softkey to make the selection and go back to the **Channel Setup** screen.





7. The screen shows the **Scaling**  icon in the **PROCESS** field. The special unit label is in the **UNITS** field. Select the **Back**  Softkey to go back to the **Calibrator** screen.
8. The screen shows the **Scaling**  icon in the related channel window. The **UNITS** field shows the set special label. In addition, the full-scale value will be shown as its equivalent in the special unit.

Examine the minimum and maximum shown values that relate to the minimum and maximum measured values.

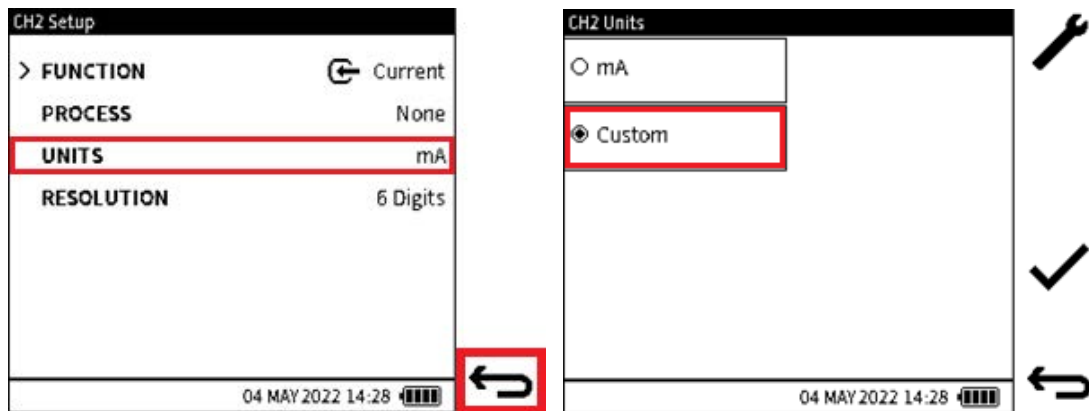
6.4.6.2 Scaling Method 2



1. Select the ^{CH1}  or ^{CH2}  icon for the wanted **Setup** channel.
Select the **UNITS** field in the channel **Setup** screen (refer to steps 1 to 4 in Section 6.4.6.1).
2. Select the **Custom** option.

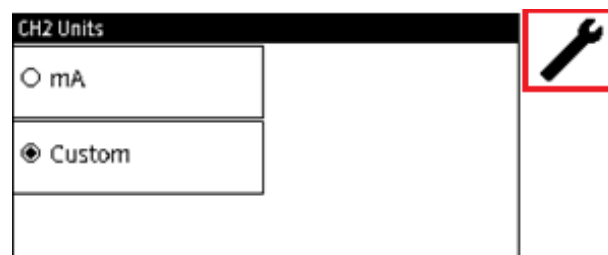

3. Select the **Setup**  Softkey to see or change the **Scaling** parameters which set the special unit. For information for how to set the parameters, see Section 6.4.6.1 for Method 1.

7. Utilities

Pressure functions give these utilities or tests:

- Leak Test
- Switch Test
- TX Simulator
- Relief Valve Test.

The **Tasks** menu gives access to these utilities. Only a utility function makes available pressure measure functions. This screen also has five other tests. See “Tasks” on page 33.

When the Leak Test, Switch Test and Relief Valve Tests are done, you can save the test results in the DPI610E. These result files are in the CSV format and can be looked at when moved to a PC (See Section 5.3.1 on page 42). This is why the Data logging application does not support these tests.

The Transmitter Simulation (TX SIM) utility is supported by Data logging.

7.1 Leak Test

A Leak Test is usually done to make sure that the pressurized equipment or system and its related components do not leak. A Device Under Test (DUT) can connect to the DPI610E pressure Test Port, either directly or by the use of hoses and auxiliary connections. It is a good precaution to do a check for any possible leaks before calibration or any other tests are started. In a Leak Test, pressure (or vacuum) is applied to the system (typically to full-scale of the device or system under test) and any change in this pressure is recorded while the test occurs.

To set and do a Leak Test:

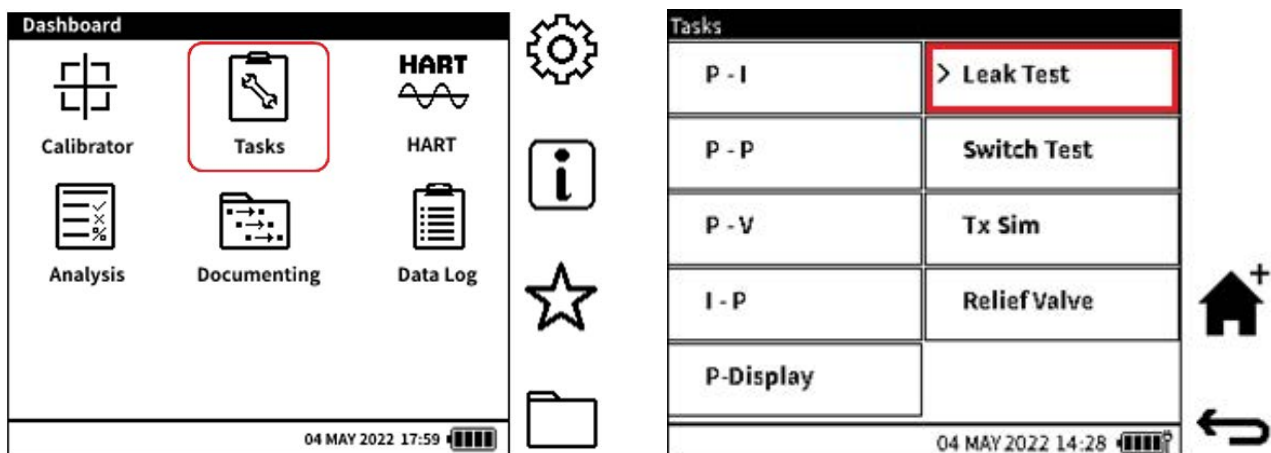

1. Tap on the **Tasks** icon on the Dashboard to select the menu.
2. From the **Tasks** menu, select **Leak Test**. Tap the **Leak Test** option again on the Touchscreen or push the Navigation Pad **OK**  button to start the **Leak Test** utility.

Note: If no compatible function is set on **CH1**, the **Internal Pressure** function will be selected for the Leak Test.

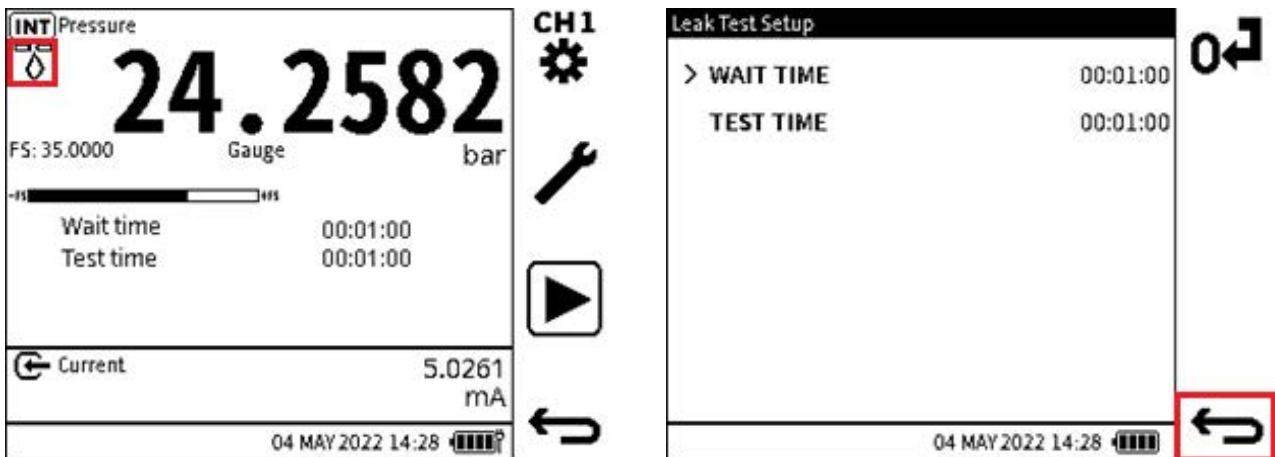

- On the Leak Test screen, **CH1** will automatically be maximized to show the related test details. The screen will show the **Leak**  icon below the Function name field. The **WAIT TIME** and **TEST TIME** are the two parameters to control the Leak Test and these are in the channel window. They use the HH:MM:SS format.

To edit the leak test times, tap on the **WAIT TIME** or **TEST TIME** text or time fields.

Alternatively, tap the **Setup** icon  to show the **Leak Test Setup** screen. Tap on the related time field or use the Navigation Pad buttons to select **WAIT TIME** or **TEST TIME**: both methods will show an on screen keypad. Use this keypad to enter the wanted time value.

- WAIT TIME** - Before a Leak Test starts, a period of time can be necessary to let the pressurized system to become stable before the test can start. This time is the **WAIT TIME** on the DPI610E and the default **WAIT TIME** is 1 minute (00:01:00). This time value can be changed to any value between 0 seconds (00:00:00) up to 60 minutes (01:00:00).
- TEST TIME** - This is the period in which the DPI610E does a test for a change in pressure (caused by leakage). The default **TEST TIME** is 1 minute (00:01:00) and this time value can be changed to any value between 1 second (00:00:01) and 480 minutes (08:00:00).



The **Leak Test Setup** screen will give the options for both the **WAIT TIME** and the **TEST TIME**.

Push the **Back** Softkey to go back to the **Leak Test** screen.

Note: the screen will only show the  icon for the use of an absolute gauge sensor.

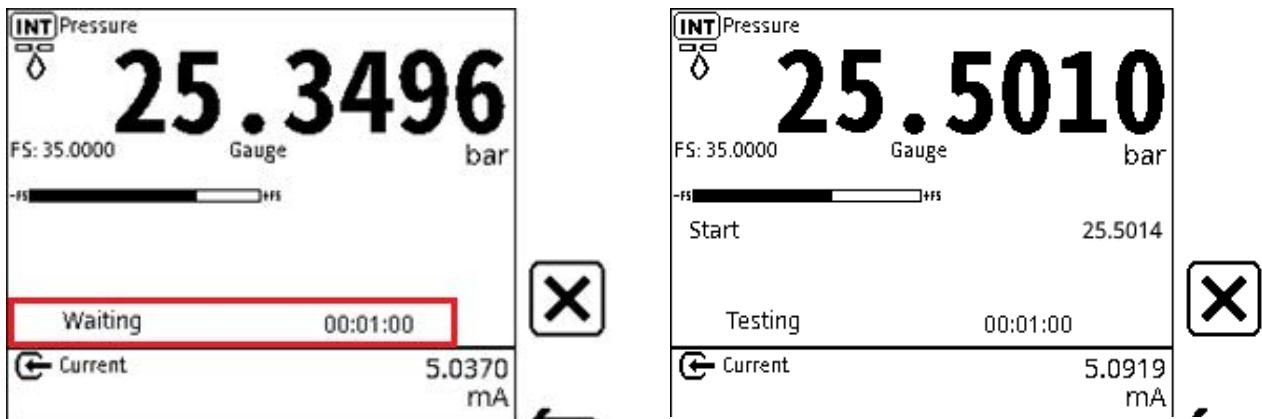
- After the Leak Test times are set, use the DPI610E pump to pressurize the system to the necessary pressure.



5. Select the **PLAY**  Softkey to start the task. This icon will change to a **STOP**  icon after selection.

Note: The shown **WAIT TIME** and **TEST TIME** settings will be erased.

Note: If a **WAIT TIME** has been set, a **Waiting** countdown starts from the **WAIT TIME** value down to zero. This must give enough time for the pressure to become stable. The test starts after this countdown comes to an end.

The Start pressure value is recorded on the screen at the start of the test. A **Testing** countdown starts from the **TEST TIME** value and goes down to zero.

When the **TEST TIME** period comes to an end, the **End** pressure value is recorded and the **Leak Rate** per minute is calculated. The screen then shows the **Leak Rate** test result.

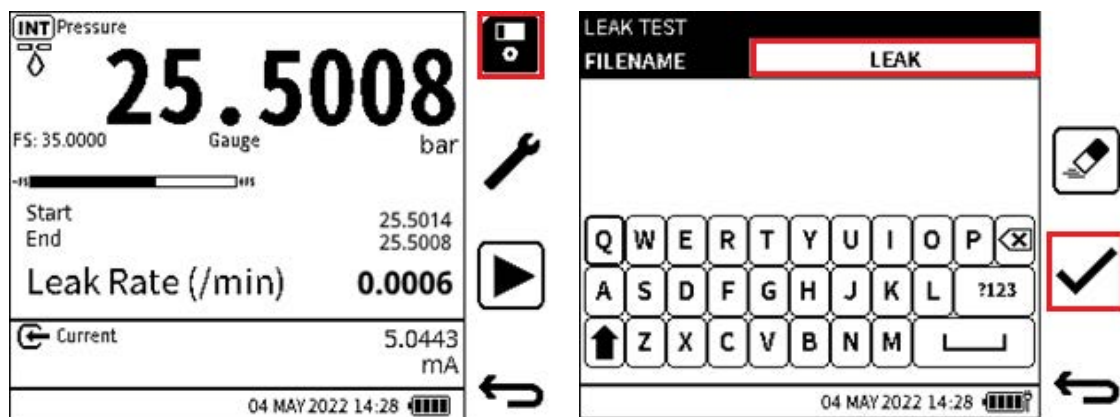

6. If you need to save the test result, select the **Save**  Softkey.

The screen shows a keypad. Use this keypad, if necessary, to enter a new name for the results file.

The default result file name will be the DPI610E date and time the file is saved. Select the **Tick** Softkey to save the file with a different file name and to complete the save process.

Note: Result files are put into the internal memory of the DPI610E. (See Chapter 15, “Files System,” on page 253.) Only the list of test result files can be looked at on the device. Data about the files can only be seen when the files are opened on a PC. See Section 10.6.2, “To View Data Log files on a PC,” on page 162.

7.2 Switch Test

The DPI610E can do checks on pressure switches or pressure devices with switch contacts. Pressure switches open or close an electrical circuit when a set pressure level or higher is sensed.

Pressure switches usually have two types of contact: normally open or normally closed. When a pressure switch is normally open, this is when the mode of the switch contacts (when pressurized in normal operating limits) is Open. When the pre-set setpoint pressure is sensed, the micro-switch is operated (Actuation) and the contacts change from open to closed. When the pressure is sensed to be in the wanted operating limits, the switch contacts are set again (De-actuation) and they change back to the usual open state.

For a normally closed switch, the opposite of the operation given above applies. At the switch point (Actuation), the mode changes from Closed to Open and at the reset point (De-actuation), it goes back to the closed mode.

The difference between the switch point and reset point is called Hysteresis.

To set and do a Switch test:

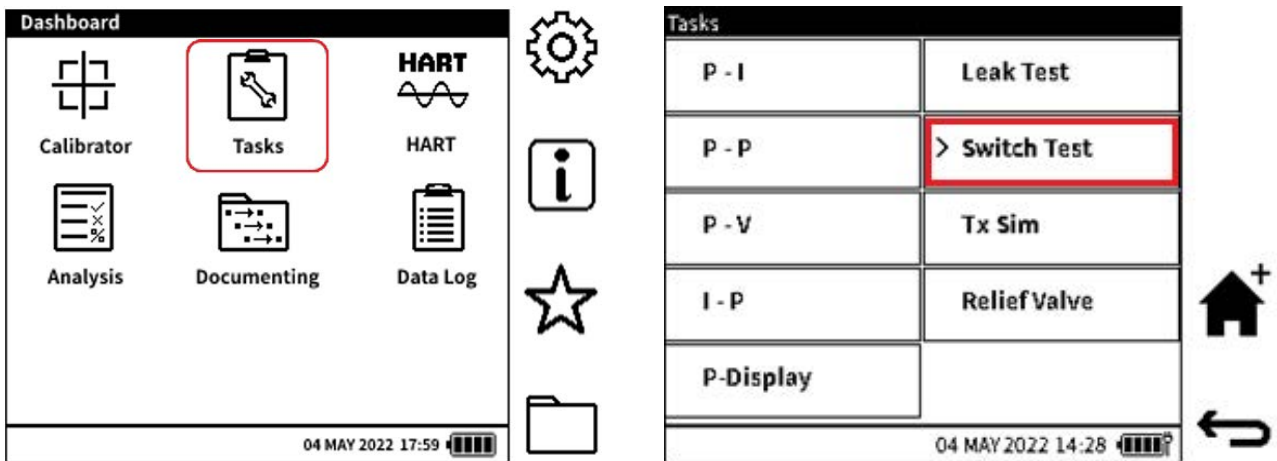

1. Tap on the **Tasks** icon on the Dashboard to select the menu.
2. Tap the **Switch Test** two times on the Touchscreen or tap the **OK** button to start the utility.

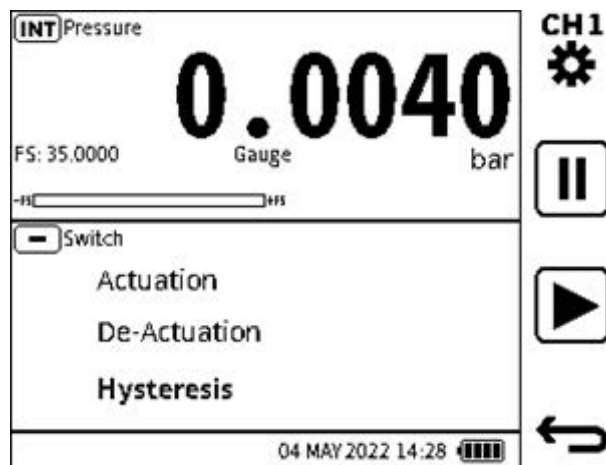



The **Calibrator** screen will be set with the **Switch Test** data. The Pressure related function is set on **CH1** while the **Switch Test** data are in the **CH2** window.

Note: Note: if no compatible function is set on **CH1**, the **Internal Pressure** function will automatically be selected for the Switch Test.

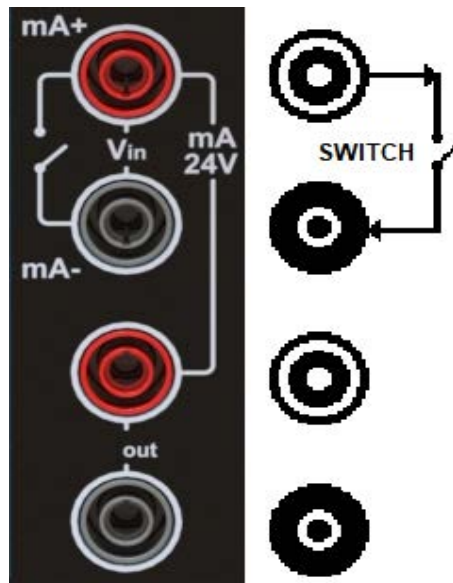
- Vent the DPI610E: loosen the Pressure Release Valve. Make sure that the screen shows a pressure value of approximately zero if a gauge sensor is used or approximately 1 bar if an absolute sensor is used.
- Connect the pressure switch or device to the Test Port correctly.



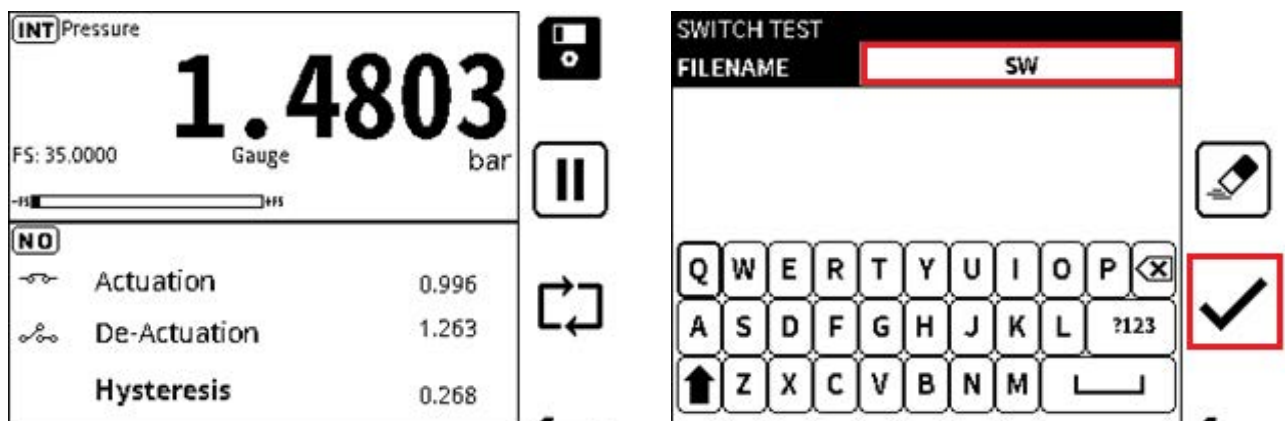

- Connect test leads from the pressure switch contacts to the \pm mA/Vin ports on the DPI610E, as shown in the connection diagram.
- Select the **PLAY**  Softkey to start the Switch Test. (This icon will change to a **STOP**  icon after selection). The normal state is sensed: If open, it is sensed as a Normally open (NO) switch in the test window. If a closed circuit is sensed, the switch will be identified as Normally closed (NC).
- Fully close the Pressure Release Valve. Make sure that there are no leaks.



Chapter 7. Utilities

8. Slowly start to pressurize the system. If the trip or actuation point is known and it is safe to do so, use the pump. Quickly increase the pressure until it is near to the setpoint. Then use the Volume Adjuster to slowly increase the pressure to the setpoint.

When the switch is actuated, the actuation pressure is recorded in the switch test channel window. The mode icon for the actuation is also shown: an icon of a switch open  or a switch closed .

Increase the pressure a little more and let it become stable.

Gradually start to reduce the pressure using the Volume Adjuster. At the switch reset (De-actuation) point, the pressure is recorded and the switch state icon at this point is shown.

The test is complete when the Hysteresis value is calculated and shown. This completes the switch test cycle.

If wanted, the test result can be saved. Select the **Save**  Softkey before the test screen is closed. The screen shows a keypad. Use this keypad to enter a new name for the results file if wanted.

If the results are saved, the test data will be erased, and the test will start again. If the results are not saved, a new switch test cycle can be set up, ready to be operate. To do this, carefully vent the system (open the Pressure Release Valve) and then select the **Restart**  Softkey.

Note: Result files are put into the internal memory of the DPI610E. See Chapter 14 (File System). Only the list of test result files can be looked at on the device. Data about the files can only be seen when the files are opened on a PC (See Section 10.6.2, “To View Data Log files on a PC,” on page 162).

7.3 TX (Transmitter Simulation) Simulator

The DPI610E gives a current output (current source) that is proportional to the pressure measured and shown by the DPI610E. The DPI610E usually uses this function to simulate a pressure transmitter. Set the transfer function parameters of the current output transmitter to do this.

To set and use the Transmitter Simulation mode:

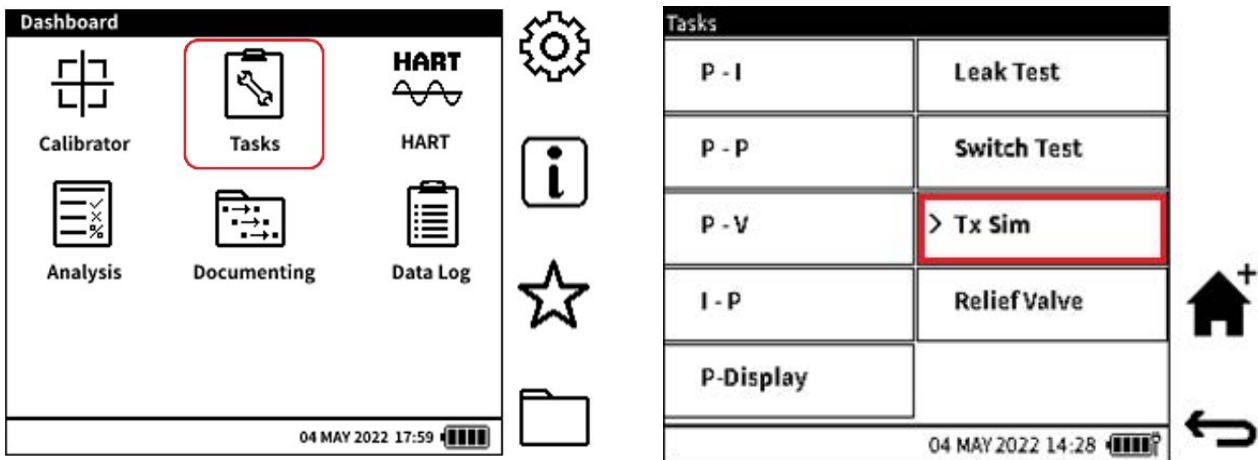

1. Tap on the **Tasks** icon on the Dashboard to select the menu.
2. From the **Tasks** menu, select **Tx Sim** from the Task list. Tap the **Tx Sim** option again on the Touchscreen or push the Navigation Pad **OK** button to start the utility.

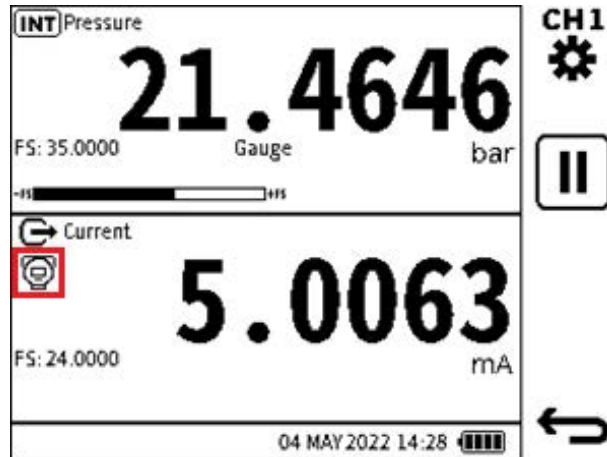

3. The **Calibrator** screen will be set with the transmitter simulation data. Use the internal pressure function to set the **CH1**. Use the **Current** source in simulation mode to set **CH2**.

The screen will show the **TX Sim**  icon in the **CH2** window, under the **Function** name field.

Note: In **TX Sim** mode, the current output is automatically calculated, shown and output, and the source based on the set transfer function characteristic.

Transmitter Simulation Setup		
	INPUT	OUTPUT
FUNCTION	Pressure	Current
UNITS	bar	mA
START	> 0.0000	-24.0000
END	35.0000	24.0000
LOOP	Off	



4. To set the simulated transmitter:

Tap in the **CH2** area to maximize the **CH2** window and select the **Setup**  Softkey.

Select and change the **START** and **END** values of the Input channel (the **Pressure** channel). Default values are the zero (or Negative full-scale) and the Positive full-scale of the internal pressure sensor.

Select and change the **Start** and **End** values of the **OUTPUT** channel (the current source channel). Values automatically used are 0 and 24 mA.

There is also the option for the DPI610E to supply loop power (10 V or 24 V). The usual setting is **Off** (no power supplied by the DPI610E).

Push the **Back**  Softkey.

7.4 Relief Valve Test

Pressure relief valves control or set limits for the pressure in a system. Too much pressure (overpressure or vacuum) can make equipment malfunction. Use the Relief Valve utility to do tests on pressure or vacuum relief valves. Pressure relief valves open at a set pressure, to release pressure that is too high, and close when the system goes to its correct pressure limit. Vacuum relief valves open to prevent a internal vacuum pressure that is too high and close when the system goes to the correct pressure limit.

To set and do a Relief Valve test:

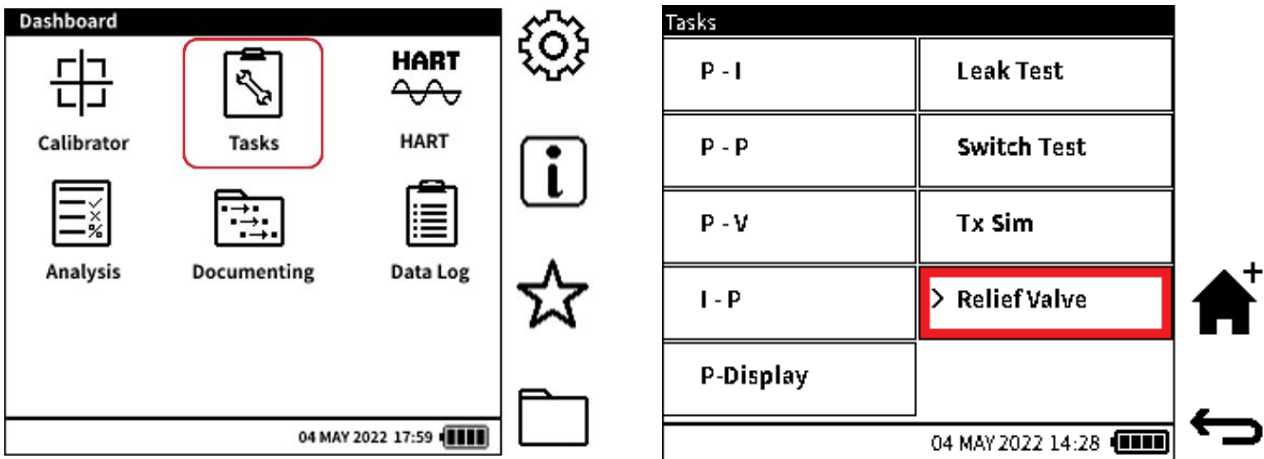



1. Tap on the **Tasks** icon on the Dashboard to select the menu.
2. From the **Tasks** menu, select **Relief Valve** from the **Task** list. Tap the **Relief Valve** option again if the Touchscreen is used or push the Navigation Pad **OK** button to start the utility.





3. The Calibrator screen will be set with the **Relief Valve** Test data. The **CH1** window will automatically become larger to show the test data.

Note: the default **Relief Valve** mode  is **Rising**.

To change the Relief Valve type, select the **Setup**  Softkey and select the wanted type. Select the **Tick** Softkey to set and go back to the **Calibrator** screen. The screen will show the related Relief Valve type icon in the channel window under the Function name field.

4. Vent the pressure on the DPI610E: fully turn the Pressure Release Valve counterclockwise to open the valve.
5. Connect the Device Under Test (DUT) correctly to the pressure Test Port of the DPI610E.
6. Seal the pressure system: close the pressure release valve.
7. Select the **PLAY**  Softkey to start the Relief Valve test. The screen will start to show the **Opening** and **Closing** values.

If in **Rising Relief Valve** mode , the **Opening** pressure is shown as the maximum pressure sensed after the test has started, and continuously changes. The **Closing** pressure is shown as the minimum pressure sensed each time a new maximum pressure is recorded.

If in **Falling Relief Valve** mode , the operation is the opposite of the above paragraph. The **Opening** pressure is shown as the minimum pressure sensed after the test starts. The **Closing** pressure is shown as the maximum pressure sensed each time a new minimum pressure is recorded.

When the **Rising Relief Valve** mode  is used, use the pump to gradually increase the pressure or use the Volume Adjuster. Do this until the reading is near the Relief valve setpoint or blow-down pressure. The pressure reading will start to decrease when more pressure is applied. The **Opening** pressure value must become stable and not increase. This is recorded as the final opening pressure. At this point stop pumping. This will allow the relief valve to release the pressure to allow the system pressure to drop below the setpoint pressure.

When the pressure becomes stable below the setpoint level, the valve will close, and the pressure reading will become stable at a minimum value: this is recorded as the final closing pressure.

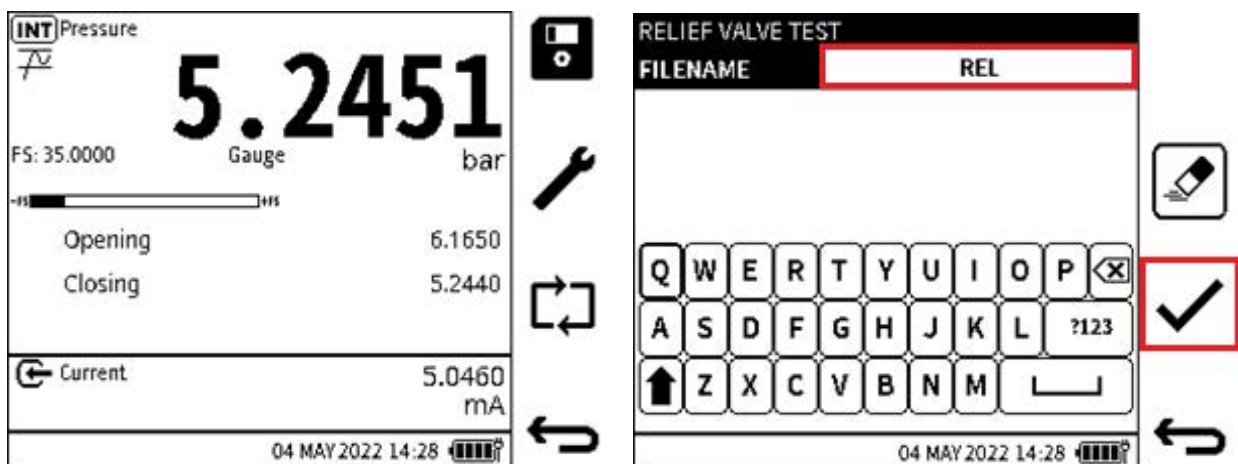

8. When the **Open** and **Close** pressures are stable, select the **Stop**  icon Softkey to end the test.

Select the **Save**  Softkey, to save the results of the Relief Valve test.

9. The automatic result file name will be the DPI610E current date and time stamp. This can be changed if necessary. Select the **Tick** Softkey to set the Result file name and complete the **Save** operation.

Chapter 7. Utilities

If the results are saved, the test data will be erased, and the test can be started again. If the results are not saved, a new test cycle can be set up ready to be used. To do this, carefully vent the system (open the Pressure Release Valve) and then select the **Restart**  Softkey.

Note: The internal memory of the DPI610E holds the Relief Valve Test result files. (See Section 15.8 on page 256.) Only the list of test result files can be looked at on the device. Data about the files can only be seen when the files are opened on a PC (See Section 10.6.2, “To View Data Log files on a PC,” on page 162).

8. The DPI610E-A Instrument



The DPI610E-A is a pneumatic variant of the DPI610E instrument for use in the Aerospace industry. Its Dashboard screen has the added Aeronautical option (Aero). All other functions and tasks are the same as for the other DPI610E instruments.

The DPI610E-A has a limited flowrate source of pressure or vacuum, for tests of aircraft pitot and static port indicators. This instrument simulates the effect of altitude by the application of airspeed conditions by the application of a pressure. It can also do Leak rate or Switch test tasks in its altitude or airspeed mode.

The DPI610E-A has a special manifold with a flowrate limiter. The flowrate limiter controls the flowrate into the equipment under test. This prevents damage to sensitive Rate of Climb meters. The applied pressure or vacuum goes to atmosphere through the vent port.

Quick-fit let-down adapters are available for AN4, AN6, Staubli and Hansen 7/16-20 and 9/16-18, all of which have a Let-down Valve. This valve brings the aircraft instruments down to 'ground' pressure.

8.1 How to Vent the Instrument to Atmosphere

For safety reasons always vent the instrument (and the system to be tested) to atmospheric pressure before use. The output port has a manual Let-down Valve. Use the pressure release valve to first vent the instrument to a safe operational level < 1500 ft (53 mbarg). Then slowly open the let-down valve to fully vent the system (go down to ground level pressure).

The instrument can operate with 5 meters of 6 mm internal diameter pipe that connects to the output port. When connected to a total volume of 1 liter (equivalent to a typical mechanical Rate of Climb meter) the rate of climb will be limited to +/- 6000 ft/min to protect the attached device.

The DPI610E-A menu has three options: **None**, **Altitude** and **Airspeed**. Select **None** when the instrument only has to show readings on its display. This chapter gives the procedures for the **Altitude** and **Airspeed** functions.



WARNING Read through all this instructions in this chapter before use of the instrument. This is for the safety of personnel and to prevent damage to equipment.

8.2 Controls and Connection

See “Parts” on page 11.

8.3 Pressure of the Day (POTD) Correction

You can need to enter the Pressure of the Day (POTD) value into the instrument to make sure the measured pressure (altimeter) values are accurate. The POTD can either take its value from the instrument’s barometric sensor (live value) or the user can manually enter the value (static value). The procedure to enter the POTD is given in “How to Set and do an Altitude Leak Test” on page 106.

8.4 Altitude Leak Test

An Altitude Leak Test is done to make sure that the pressurized equipment or system and its related parts do not leak. A device connects to the DPI610E-A pressure Test Port either directly or by the use of hoses and auxiliary connections. It is good practice to do a check for possible leaks.

In a Leak Test, pressure (or vacuum) is applied to the system (approximately full-scale of the device under test) and any change in this altitude through the test period is recorded.



INFORMATION Movement or compression of connecting hoses can affect measured readings. Keep hoses stable while taking measurements.



WARNING Always vent the static system on the aircraft to atmosphere before you make connections and start a test. Stored pressure can be dangerous to personnel and equipment. Turn the Pressure Release Valve and the Let-down Valve counterclockwise to open the valves and vent the system.

8.4.1 How to Set and do an Altitude Leak Test

1. Make sure the instrument is safe to use before operation. Vent the static system to atmosphere, before connection of the instrument (refer to Section 8.1 on page 105). Make sure that all the necessary connections between the instrument and the system to be tested are safe.

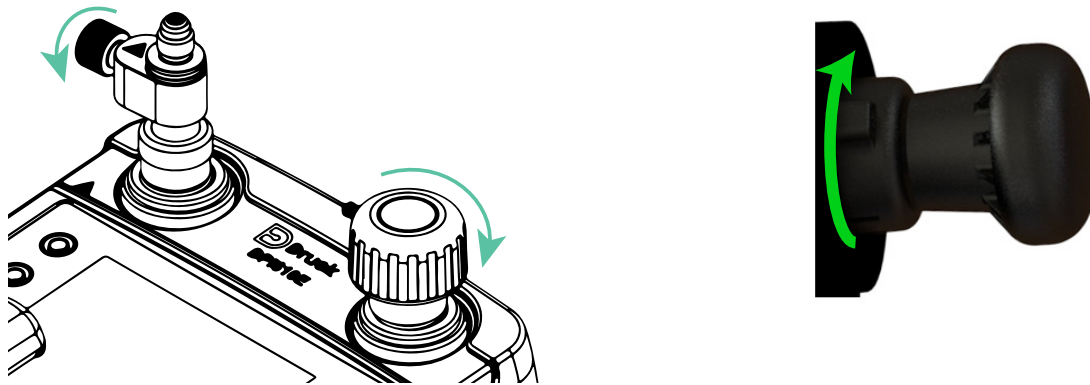

2. Make sure that the Let-down Valve and Release Valve are closed (turn both valves fully clockwise).
3. Turn the Pressure/Vacuum Selector fully clockwise to vacuum setting.

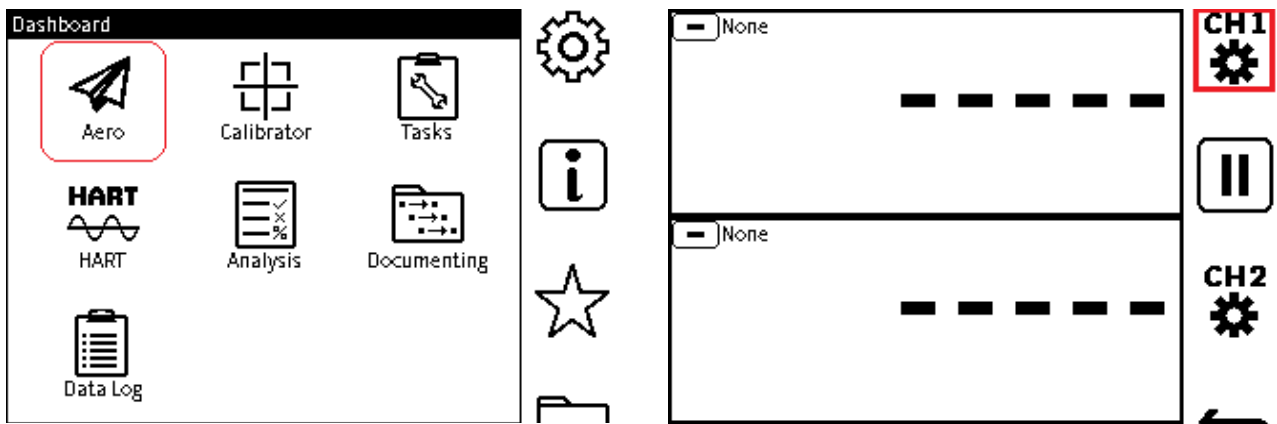

4. Tap on the **Aero** icon on the Dashboard to launch the Aero application.
5. Select the **CH1 Channel**, tap on the screen icon  or use the related Softkey.
Note: If the Aero application has already been used, the last saved channel configuration will be shown.

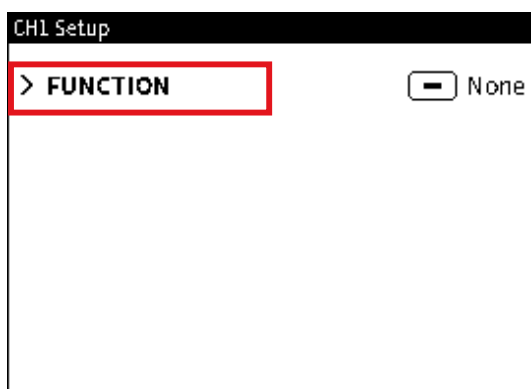

CH1 Function	
FUNCTION	TASK
None	Leak Test
Altitude	Switch Test
Airspeed	None



Chapter 8. The DPI610E-A Instrument

6. Select **FUNCTION** on the **CH1 Setup** screen to show the **CH1 Function** screen.
7. Select **Altitude** and then **Leak Test** from the **CH1 Function** screen.

Tap the Tick  icon or tap the icon's related Softkey.

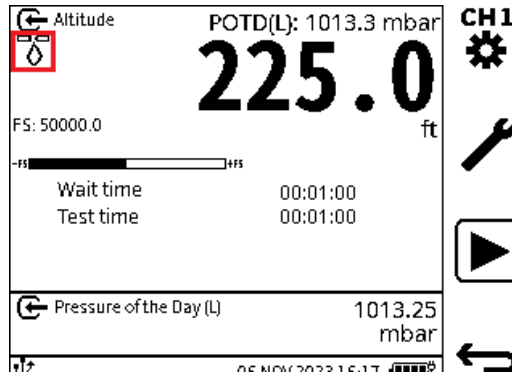



8. The display shows the main reading screen with the two channels again.

The **Leak Test**  icon will appear below the Function name field.

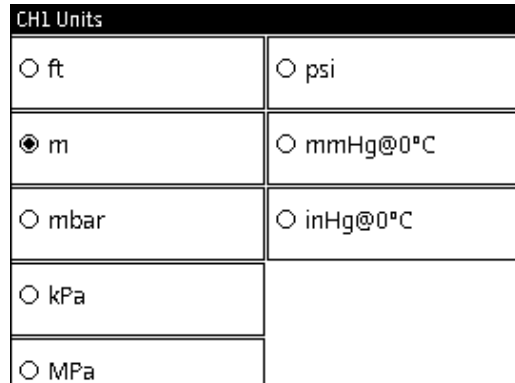
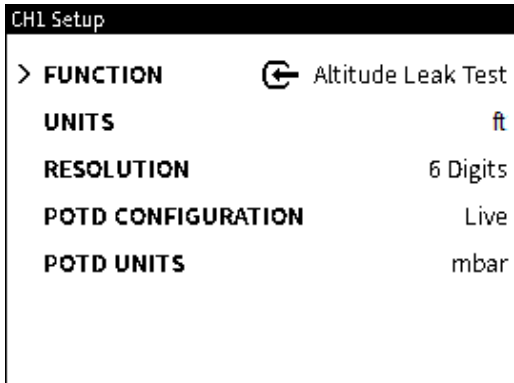
The POTD (L) value will use the real-time value from the instrument's internal barometer (it is not a stored value from previous use).



9. If the unit of measurement has to be changed, tap the **CH1**  icon again to show the **CH1 Setup** screen.

Select the **UNITS** row. Tap the row or use the Navigation Pad buttons to move the cursor to the row and tap the **Enter**  button.

10. Tap in the field that has the different measurement unit and then tap the **Tick**  icon. This will change the measurement unit and show the **CH1 Setup** screen again.

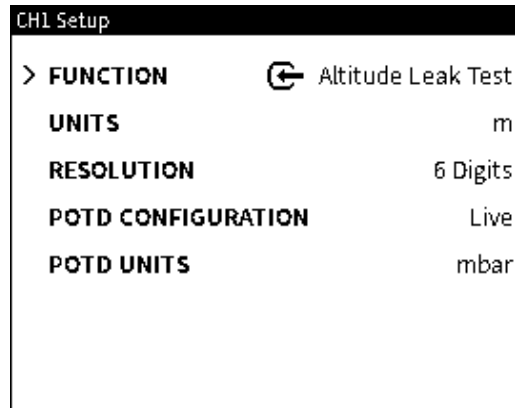

11. If wanted, select **RESOLUTION** to change the shown resolution.
12. Select **POTD CONFIGURATION** (Pressure Of The Day) to change the POTD mode if necessary: it can be **Live** or **Manual**. The **Live** value comes from the instrument's shown real-time internal barometric pressure and is the default mode. **Manual** is a set value given by the user.

Select **POTD UNITS** if you want to change the measurement unit for the POTD value.

When all the option values have been selected, tap the **Back**  icon.

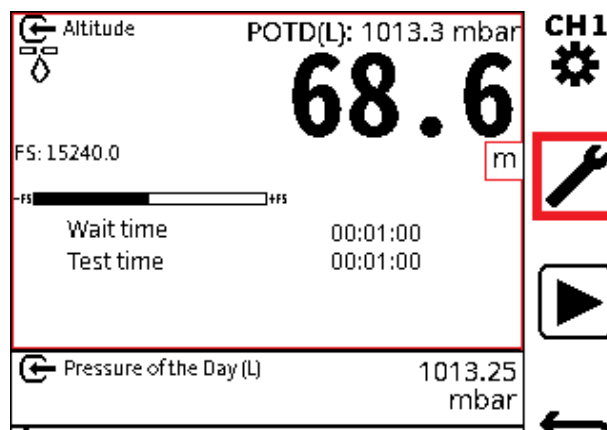

13. Tap in the **CH1** window to maximize it. **Do not** tap in the units (ft | m) area because this will show the selection screen for measurement units.

The screen shows the **Setup**  icon. Select this icon to show the **Leak Test Setup** screen. The format for the **Wait time** and **Test time** is: HH:MM:SS (Hours, Minutes, Seconds).

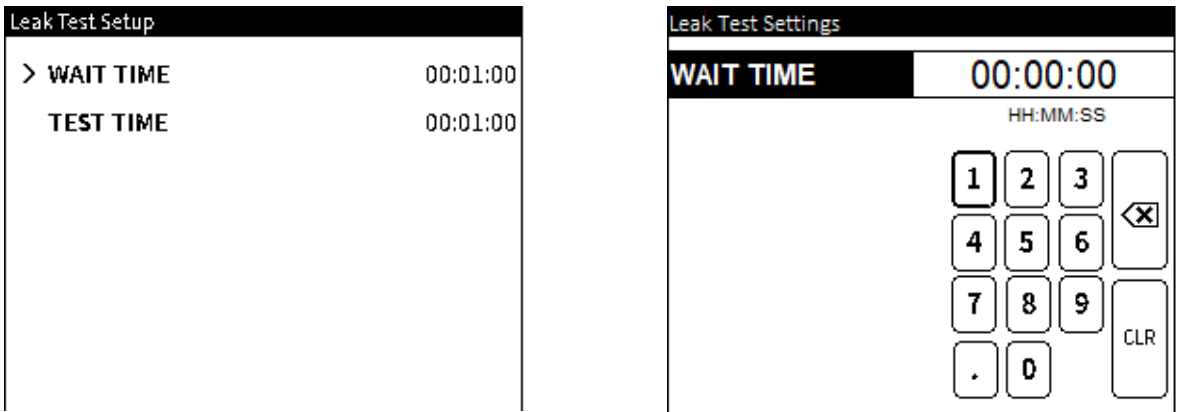

14. Set the values for the leak test **WAIT TIME** (if wanted) and **TEST TIME**.

The **WAIT TIME** is the time necessary for the system pressure to become stable. This period also minimizes the adiabatic effects of heating/cooling before the test starts.

Select the **WAIT TIME** row: tap on the row (or use the related Navigation Pad buttons) to show an on-screen keypad. Use the keypad to enter the time. Tap the **Back** icon to close the keypad.

Select the **TEST TIME** row and enter the wanted test period and then tap the **Back** icon to close the keypad.

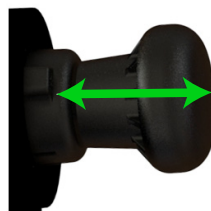

15. Set the instrument against a flat surface to prevent it from sliding. Tap the **Start/Play** button (Softkey 3), then use the pump handle to supply the wanted vacuum. Stop the use of the pump when the wanted vacuum is shown on the display screen.

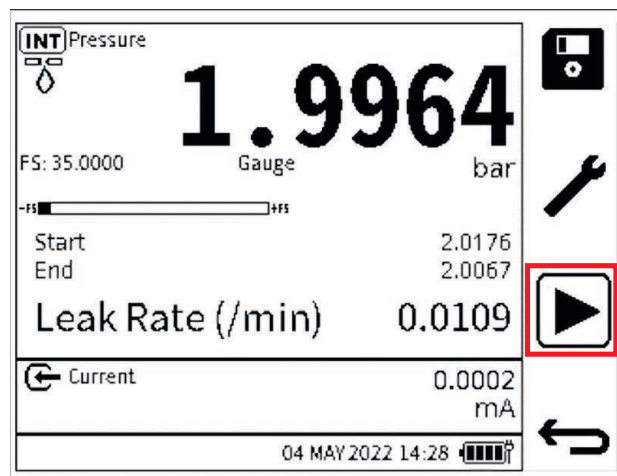

16. Tap the **Play** icon to start the Leak Test. (This icon will change to a **STOP** icon after selection).

Note: Note: If a **WAIT TIME** has been set, a “Waiting” countdown will start from the **WAIT TIME** value down to zero. This gives sufficient time for the pressure to become stable. The test starts after this countdown finishes. The **Start** pressure value is recorded on the screen at the start of the test.

A “Testing” countdown starts from the **TEST TIME** value and decreases to zero.

When the **TEST TIME** period comes to an end, the screen shows the **End** pressure value and the **Leak Rate** per minute is calculated. The screen then shows the Leak Rate test result.



17. You can save the test results. To do this select the **Save**  Softkey before the test procedure completes. A keypad appears on the screen. Use this keypad if you want to enter a new name for the results file. The default result filename will be the DPI610E date and time. Select the **Tick** Softkey to set the different filename and complete the save process.

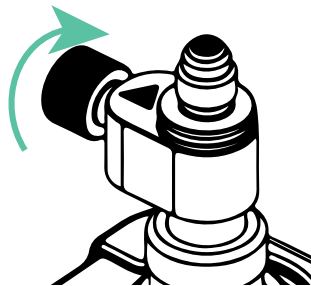

18. Turn the Let-down Valve fully counterclockwise to open the valve and allow the system pressure to drop to ground level pressure.

Note: See Section 10.6.2, “To View Data Log files on a PC,” on page 162. Result files are saved in the internal memory of the DPI610E. (See Chapter 15, “Files System,” on page 253.) Only the list of test result files can be seen on the device. You must open the files on a PC to get access to their data.

8.5 Altitude Switch Test

The DPI610E-A can test altitude pressure switches or altitude pressure devices with switch contacts and indicators. Pressure switches open or close an electrical circuit when a set pressure level (setpoint) is sensed or passed. The **CH2** screen shows switch test data.

Pressure switches can use two types of contact: Normally Open (NO) or Normally Closed (NC). Different procedures are necessary for switches whose electrical contacts are accessible and those that are not.

Chapter 8. The DPI610E-A Instrument

in some conditions you will not be able to connect altitude switch contacts to the instrument. In this situation, use an external indicator or annunciator to show the pressure switch operation: the “manual” mode of the DPI610E-A must also be selected. When the start of the switch operation is shown, the user taps an icon to tell the system that the switch has activated - at which point it will record the pressure.

Hysteresis is the difference between the activation point from a rise in pressure and de-activation point from a decrease in pressure (or vice-versa).

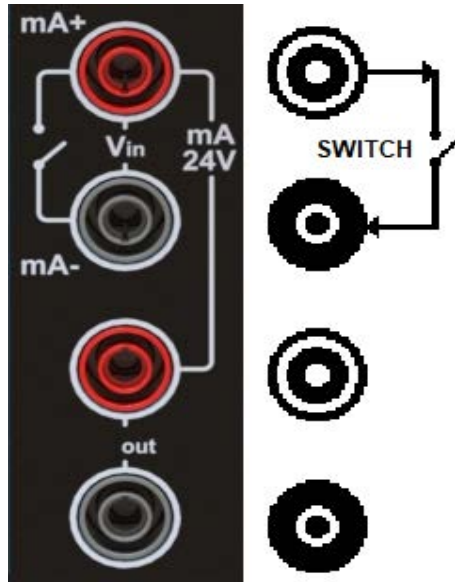

Figure 8-1: Altitude Switch Test Connections

8.5.1 How to do an Altitude Switch Test (Accessible Switch Contacts)

1. Connect the instrument to the static system of the aircraft being tested and connect the electrical leads of the altitude switch as shown in the image. Make sure the switch contacts on devices under test are voltage free.
2. Make sure the instrument is safe to use before operation. Vent the pitot system to atmosphere, before connection of the instrument (refer to Section 8.1 on page 105). Do this to make sure there is no dangerous pressure or vacuum in the system to be tested. Make sure that all the necessary connections between the instrument and the system to be tested are safe.



3. Make sure that the Let-down Valve is closed (turn the valve fully clockwise).
4. Turn the Pressure/Vacuum Selector fully clockwise to the vacuum setting.
5. Turn the Release Valve fully clockwise to close the valve.

CH1 Function		
FUNCTION	TASK	MODE
None	Leak Test	Auto
Altitude	Switch Test	Manual (NC)
Airspeed	None	Manual (NO)



6. Select the **CH1 Function** screen.

Select **Altitude** > **Switch Test** on this screen, and then the mode of the test.

There are three test modes available:

- **Auto** - Select this option if the switch contacts are to be sensed automatically. The other two modes are to be used when the valve electrical contacts are not accessible.
- **Manual (NC)** - Select to test a Normally Closed switch.
- **Manual (NO)** - Select to test a Normally Open switch.

Tap the **Tick** icon to show the next screen.

CH1 Setup	
> FUNCTION	← Altitude Switch Test (A)
UNITS	ft
RESOLUTION	6 Digits
POTD CONFIGURATION	Live
POTD UNITS	mbar

7. When the **Auto** mode is selected and the **Tick** icon tapped, the display will show the **CH1 Setup** screen for the selected test.

If necessary, make changes to the channel options on this setup screen.

Tap the **Back** icon to continue.

← Altitude
Barometric: 1013.250 mbar
CH1

49995.1

FS: 50000.0
ft



-FS+FS

NC	Switch (Manual NC)	
	Actuation	49995.1
	De-Actuation	0.000
	Hysteresis	0.000

↶
12 OCT 2023 16:05



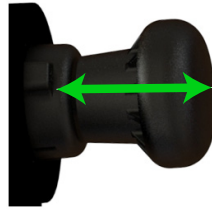

Chapter 8. The DPI610E-A Instrument

8. Tap the **Play**  icon. It will change to a **Stop**  icon. At this point, the contact state is detected and this determines if the switch is a normally open (NO) or normally closed (NC) switch. The relevant switch type is shown in the switch channel.



9. **Slowly** operate the pump until the switch changes state.

If the test has to be temporarily stopped, tap the **Hold**  icon. Tap the **Hold**  icon again to make the test continue. To stop the test completely, tap the **Stop**  icon.

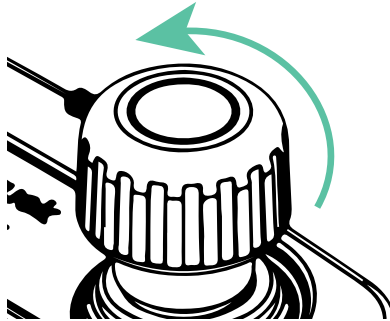

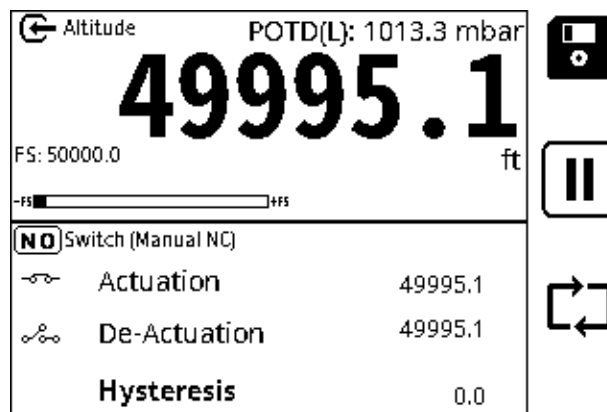

10. **Slowly** open the Release valve and let the altitude pressure decrease until the switch changes state again.

For an **Auto** mode switch test, the switch actuation and de-actuation altitude values are captured and shown in the test channel.



11. At the end of the test the Actuation and De-actuation and Hysteresis value are shown.

Select the **Save**  Softkey to save the test data if wanted. There is an option to do the test again: select the **Restart**  icon.

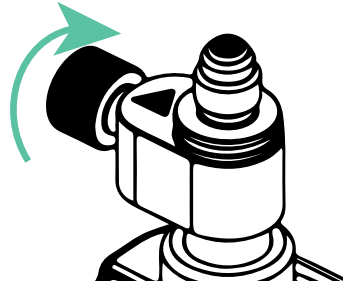

12. Turn the Let-down Valve fully counterclockwise to open the valve and make the system pressure go to ground level pressure.

Note: Result files are stored in the internal memory of the DPI610E. See Chapter 14 (File System). Only the list of test result files can be seen on the device. Use a PC to view the files (See Section 10.6.2, “To View Data Log files on a PC,” on page 162).

8.5.2 How to do an Altitude Switch Test (Non-accessible Switch Contacts)

When the altitude switch contacts cannot connect to the instrument, use an external indicator or annunciator to show the switch operation.

1. Make sure the instrument is safe to use before operation. Vent the pitot system to atmosphere before connection of the instrument (refer to Section 8.1 on page 105). Do this to make sure there is no dangerous pressure or vacuum in the system to be tested. Make sure that all the necessary connections between the instrument and the system to be tested are safe.

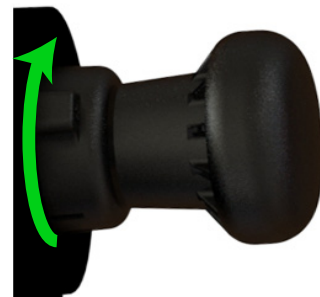
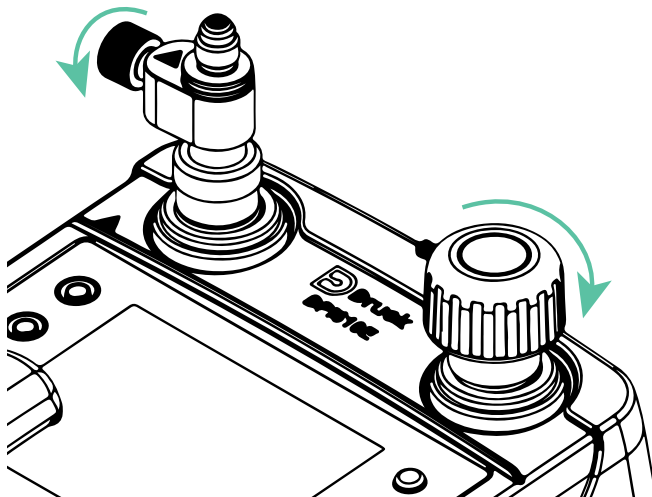

2. Make sure that the Let-down Valve and the Release Valve are closed (turn both valves fully clockwise).
3. Turn the Pressure/Vacuum Selector fully clockwise to the vacuum setting.

CH1 Function		
FUNCTION	TASK	MODE
None	Leak Test	Auto
Altitude	Switch Test	Manual (NC)
Airspeed	None	Manual (NO)



- Select the **CH1 Function** screen.

Select **Altitude > Switch Test** on this screen, and then the mode of the test.

There are two test modes that can be used for non-accessible switch contacts:



 - **Manual (NC)** - Select to test a Normally Closed switch.
 - **Manual (NO)** - Select to test a Normally Open switch.

The screen will have a different icon for each type of switch.
- When the **Manual (NC)** (or **Manual (NO)**) mode is selected and the **Tick**  icon tapped, the display will show the **CH1 Setup** screen for the selected test.

If necessary, make changes to the values of the options on this screen.

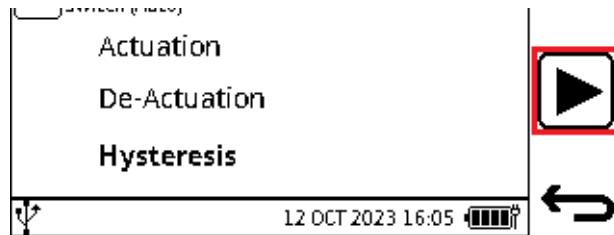

Tap the **Back**  icon to continue.

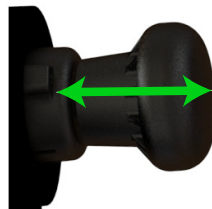

- Tap the **Play**  icon (the icon changes to a **Stop**  icon).

To stop the test completely, tap the **Stop**  icon.



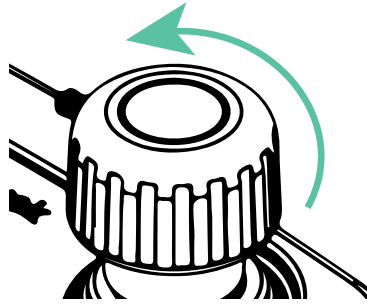

- Operate the pump until the switch operates, then tap the **Valve Open**  icon (Actuation) for a **Manual (NC)** switch test. If a **Manual (NO)** switch test is selected, tap the **Switch Close**  icon (Actuation).



- Carefully open the Release Valve (turn the valve counterclockwise) or use the Volume Adjuster until the switch operates again.



Close the Release Valve or stop operating the Volume Adjuster at the exact point of switch de-actuation. Tap the **Switch Close**  icon (Actuation) for a **Manual (NC)** switch test.

When a **Manual (NO)** switch test is selected, tap the **Switch Open**  icon (Actuation) switch icon to make a record of the pressure at which the switch operates.

Altitude Switch (Pressure) (kg)		
	Actuation	500.000
	De-actuation	400.000
	Hysteresis	100.000

04 NOV 2023 02:13 

- At the end of the test, the screen will show the Actuation and De-actuation altitudes and Hysteresis value.

Select the **Save**  Softkey to save the test data if wanted. An option is available to do the test again: tap the **Restart**  icon.

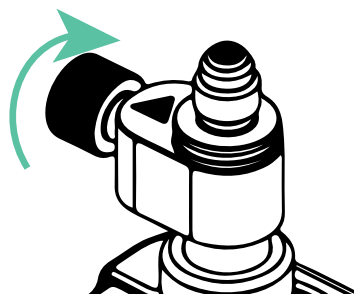

- Slowly** turn the Let-down Valve fully counterclockwise to open the valve. The system goes to ground level pressure.

8.6 Airspeed Leak Test

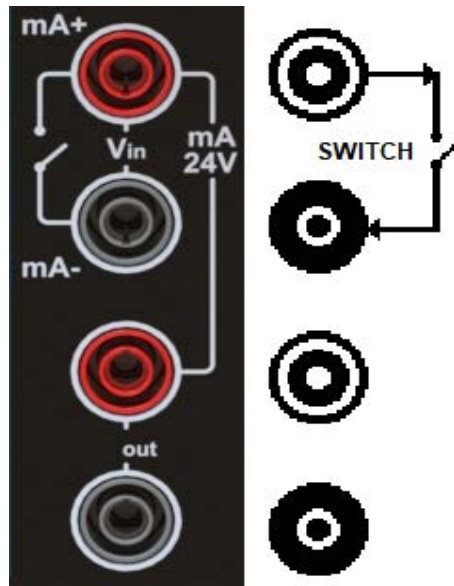

Figure 8-2: Airspeed Leak Test Connections

An Airspeed Leak Test makes sure that the pressurized equipment or system and its related parts do not leak. A device connects to the DPI610E-A pressure Test Port either directly or by the use of hoses and auxiliary connections. It is good practice to do a check for possible leaks. Do this before the calibration or for other types of tests.

In a Leak Test you apply pressure to the system (typically not more than 10% of the sensor working pressure) and record any change in this pressure through the test period.

If there is an out-of-range reading, the screen will show in the related channel, <<<<<<< for a under-range value and >>>>>>> for an over-range value.



INFORMATION Movement or compression of connecting hoses can affect measured readings. Keep hoses stable while taking measurements.



WARNING Always make sure that the static system on the aircraft is vented to atmosphere before you make connections and start a test. Stored pressure can be dangerous to personnel and equipment. Turn the Pressure Release Valve and the Let-down Valve counterclockwise to open the valves and vent the system.

8.6.1 How to Set and do an Airspeed Leak Test

1. Make sure the instrument is safe to use before operation. Vent the static system to atmosphere before connection of the instrument (refer to Section 8.1 on page 105). Do this to make sure there is no dangerous pressure or vacuum in the system to be tested. Make sure that all the necessary connections between the instrument and the system to be tested are safe.

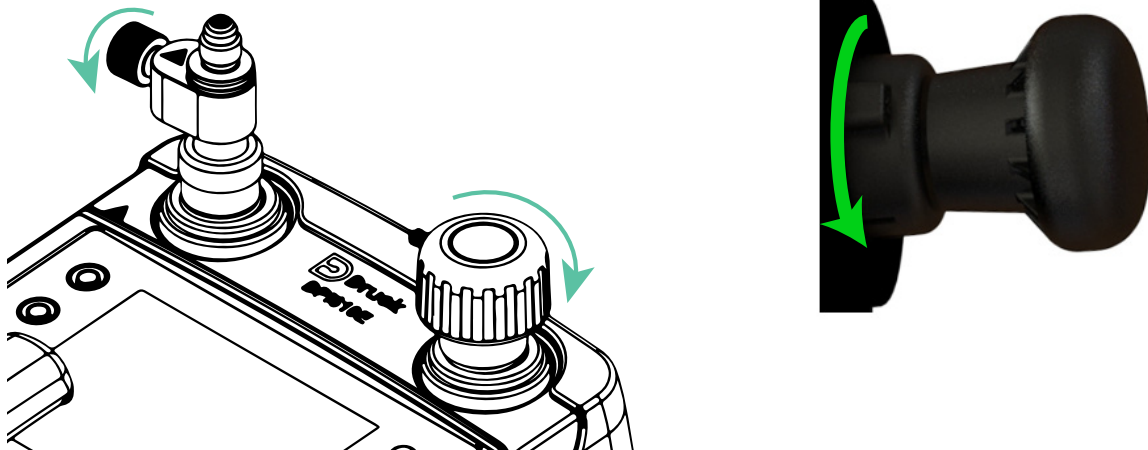

2. Make sure that the Let-down Valve is closed. Also close the Release Valve (turn both valves fully clockwise).
3. Turn the Pressure/Vacuum Selector fully counterclockwise to the pressure setting.

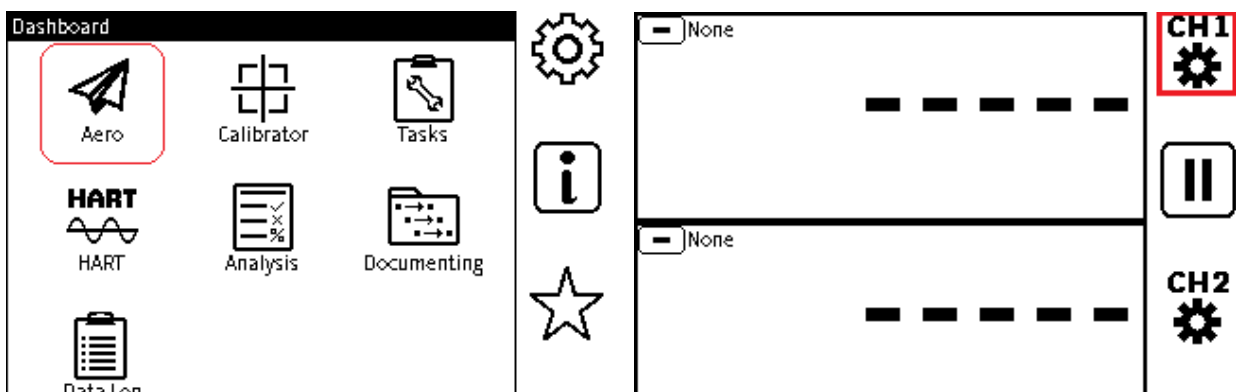

4. Tap on the **Aero** icon on the Dashboard to select the menu.
5. From the new *screen, select the **CH1 Channel**. In this example, by a tap on the screen icon ^{CH1}  or the use of the related Softkey. This shows the **CH1 Setup** screen*.
*The screen can be different from that shown, if the instrument has been used.

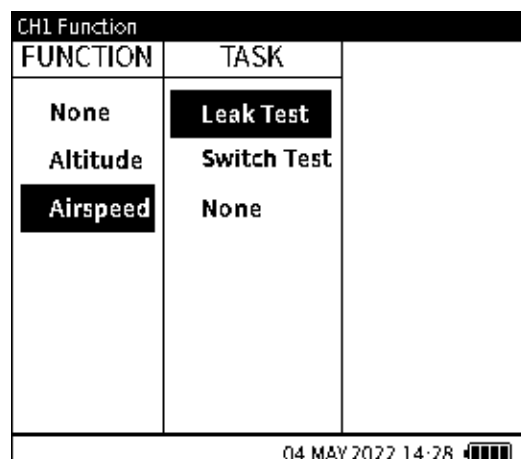
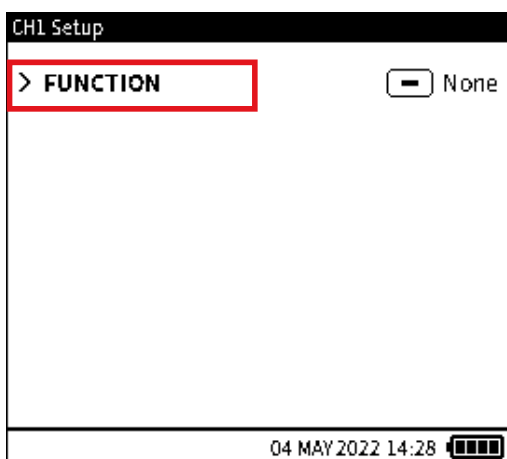

Chapter 8. The DPI610E-A Instrument

6. Select **FUNCTION** on the **CH1 Setup** screen to show the **CH1 Function** screen. The screen can be different from this example if the instrument has been used.
7. The **CH1 Function** screen must be on the display.
Select **Airspeed > Leak Test** on this screen.



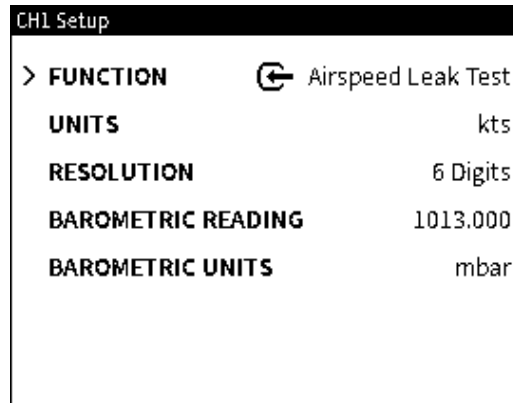

Tap the **Tick** ✓ icon to show the next screen.

The display will show a message that the pressure port must be open to atmosphere. Continue with the procedure when the pressure reading is stable.

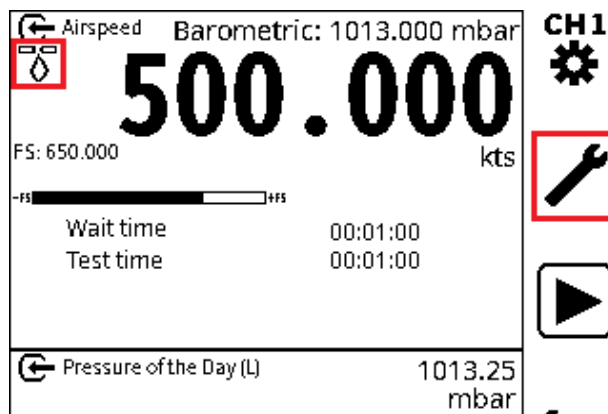

8. The **CH1 Setup** screen will show that the **Airspeed Leak Test** is selected.
If different option values are wanted, select the row of the option. For example: tap on the **UNITS** row to show a screen of measurement units available. Tap in the related field to select the measurement unit.
To increase or decrease the shown accuracy of a measurement, tap on the **RESOLUTION** row. Select the wanted number of digits (4 to 7 digits) in the shown selection screen.
Tap the **Back** ↶ icon to continue.



9. The screen will show the **Leak**  icon below the Function name field.
Tap in the **CH1** window to maximize the window and show the **Setup**  icon and **Play**  icon.
Tap the **Setup**  icon to show the **Leak Test Setup** screen.

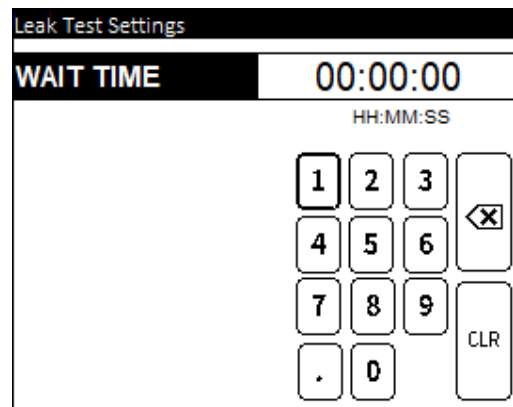
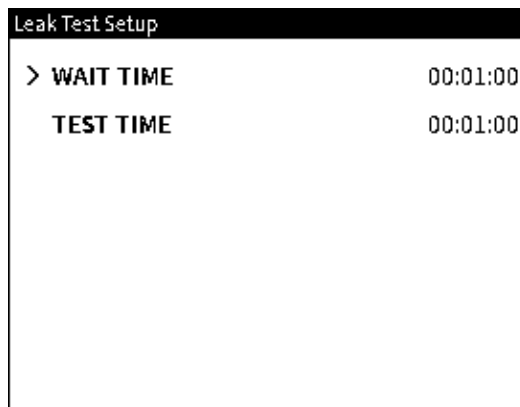

10. Set the values for the leak test **WAIT TIME** (if wanted) and **TEST TIME**.
 The format for the **WAIT TIME** and **TEST TIME** is: HH:MM:SS (Hours, Minutes, Seconds)
 Select the **WAIT TIME** row: tap on the row (or use the related Navigation Pad buttons) to show an on-screen keypad. Use the keypad to enter the time. Tap the **Back** icon to close the keypad.
 Select the **TEST TIME** row and enter the wanted test period and then tap the **Back** icon to close the keypad and show the two channel screen again.

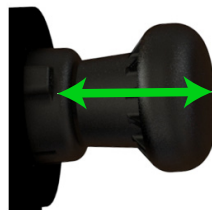

11. Set the instrument on a flat surface to prevent it sliding and **slowly** operate the pump handle to make the airspeed you want.

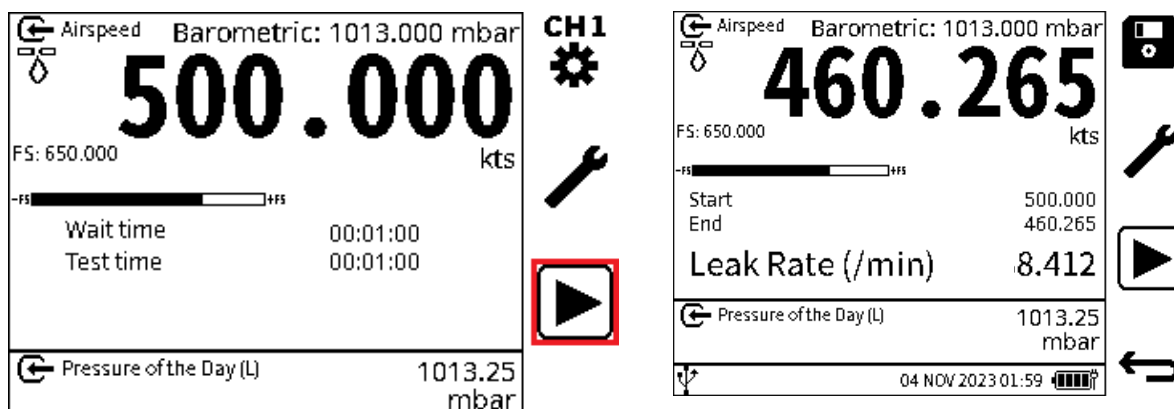

12. Tap the **Play** icon to start the Leak Test. (This icon will change to a **STOP** icon after selection).

Note: If a **WAIT TIME** has been set, a 'Waiting' countdown will start from the **WAIT TIME** value down to zero. This gives enough time for the pressure to become stable. The test starts

Chapter 8. The DPI610E-A Instrument

after this countdown finishes. The Start pressure value is recorded on the screen at the start of the test.

A 'Testing' countdown starts from the **TEST TIME** value and decreases to zero.

When the **TEST TIME** period comes to an end, the End pressure value is shown and the Leak Rate per minute is calculated. The screen then shows the Leak Rate test result.



13. If you need to save the test result, select the **Save**  Softkey before exiting the test screen. The screen shows a keypad. Use this keypad if you want to enter a new name for the results file. The default result filename will be the DPI610E date and time. Select the **Tick** Softkey to enter a different filename and complete the save procedure.
14. Slowly turn the Let-down Valve counterclockwise to put the system back to zero (ground level).

8.7 Airspeed Switch Test

8.7.1 How to do an Airspeed Switch Test (Accessible Switch Contacts)

1. Make sure the instrument is safe to use before operation. Vent the static system to be tested, to atmosphere, before connection of the instrument (refer to Section 8.1 on page 105). Do this to make sure there is no dangerous pressure or vacuum in the system to be tested. Make sure that all the necessary connections between the instrument and the system to be tested are safe. Electrical connections are shown by Figure 8.6.1 on page 118. The switch contacts must be voltage free.

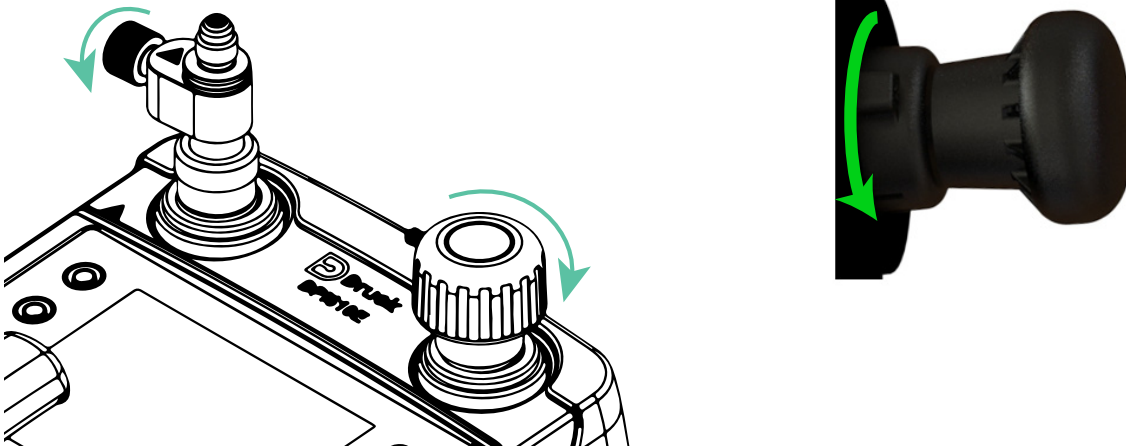

2. Make sure that the Let-down Valve is closed. Also close the Release Valve (turn both valves fully clockwise).
3. Turn the Pressure/Vacuum Selector fully counterclockwise to the pressure position.

CH1 Function		
FUNCTION	TASK	MODE
None	Leak Test	Auto
Altitude	Switch Test	Manual (NC)
Airspeed	None	Manual (NO)



4. Set the User Interface to show the **CH1 Function** screen. See section 8.6.1 to show this screen.

Select **Altitude > Switch Test > Auto** on this screen.

The screen has three test modes:

- **Auto** - Select if the switch contacts are accessible and thus can be sensed automatically. The other two modes are to be used when the valve electrical contacts are not accessible.
- **Manual (NC)** - Select to test a Normally Closed switch.
- **Manual (NO)** - Select to test a Normally Open switch.

Tap the **Tick**  icon to show the next screen.

The screen will show a message that the pressure port must be open to atmosphere. Continue with the procedure when the pressure reading is stable.

CH1 Setup	
> FUNCTION	 Airspeed Switch Test (A)
UNITS	kts
RESOLUTION	6 Digits
BAROMETRIC READING	
BAROMETRIC UNITS	mbar

5. If you return to the **CH1 Setup** screen it will show that the **Airspeed Switch Test (A)** is selected.



If you need different option values, select the row of the option. For example: tap on the **UNITS** row to show a screen of measurement units available. Tap in the related field to select the measurement unit.

To increase or decrease the shown accuracy of a measurement, tap on the **RESOLUTION** row. Select the wanted number of digits (4 to 7 digits) in the shown selection screen.

Chapter 8. The DPI610E-A Instrument

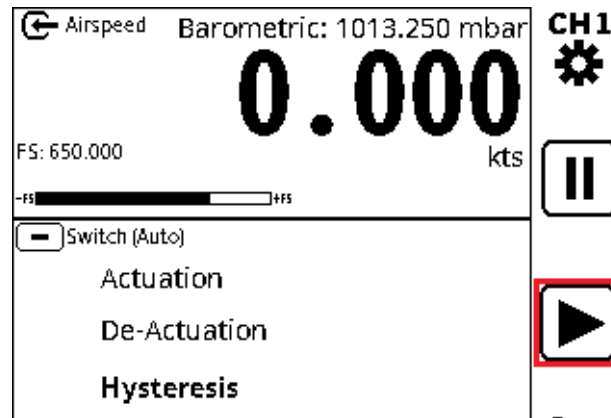

Tap the Back  icon to continue.

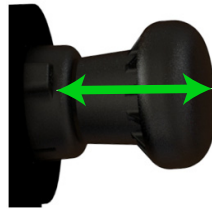

6. Tap the **Play**  icon (the icon changes to a **Stop**  icon).



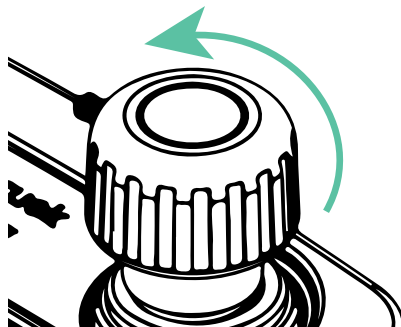

7. **Slowly** pump the handle to change pressure until the switch operates.

If the test has to be temporarily stopped, tap the **Hold**  icon. Tap the **Hold**  icon again to make the test continue. To stop the test completely, tap the **Stop**  icon.

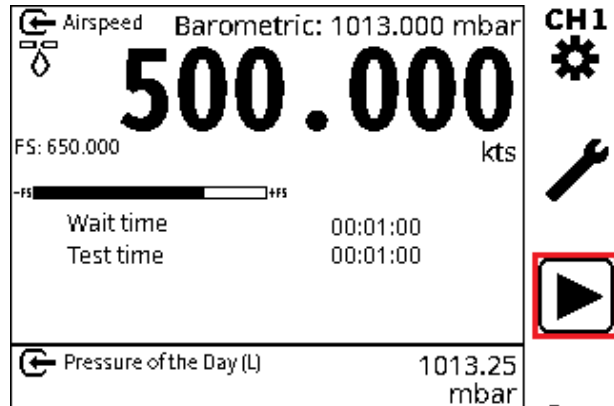

8. **Slowly** open the Release Valve and let the airspeed pressure decrease until the switch operates again.



9. The screen will show the Actuation and De-actuation air speed values and Hysteresis value. Select the **Save**  Softkey to save the test data if wanted. An option is available to do the test again: tap the **Restart**  icon.



10. The default result file name will be the instrument's date of the test and the time (HH:MM:SS). This can be renamed if necessary. Select the **Tick**  Softkey to confirm the Result file name and complete the save operation.

If the results are saved, the test details will be erased, and the test will be available to be done again.

If the results are not saved, a new test cycle can be set, ready to operate.

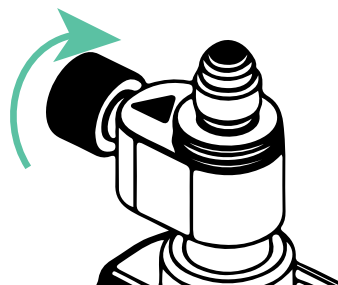

11. **Slowly** turn the Let-down Valve counterclockwise to make the system pressure go to ground level. Continue to turn the Let-down Valve fully counterclockwise to open the valve.

8.7.2 Method (Non-accessible Switch Contacts)

When the airspeed switch contacts cannot connect to the instrument, use an external indicator or annunciator to show the start of the airspeed switch operation. The user, in response to this switch operation, makes the user interface react.

Chapter 8. The DPI610E-A Instrument

1. Make sure the instrument is safe to use before operation. Vent the pitot system to be tested, to atmosphere before connection (refer to Section 8.1 on page 105). Do this to make sure there is no dangerous pressure or vacuum in the system to be tested. Make sure that all the necessary connections between the instrument and the system to be tested are safe. Electrical connections are shown by Figure 8.6.1 on page 118. The contacts must be voltage free.

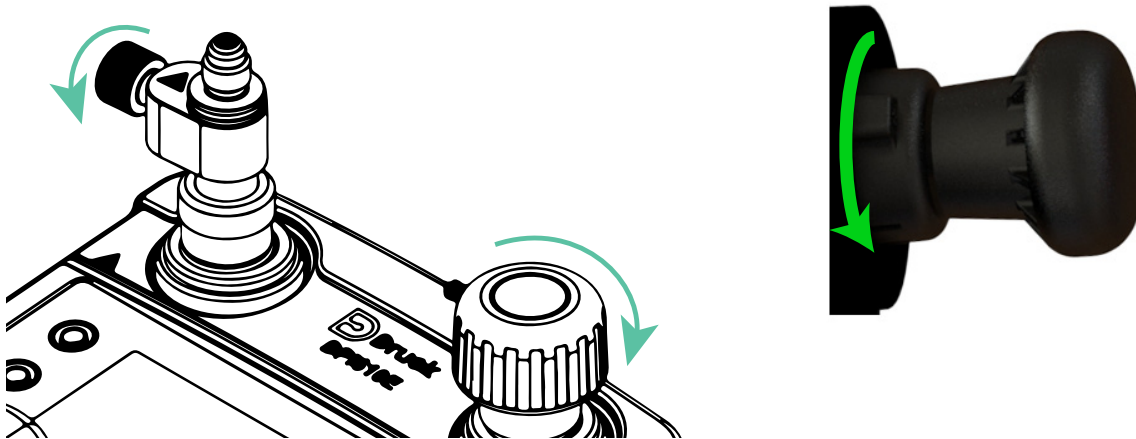

2. Close the Let-down Valve and the Release Valve (turn both valves fully clockwise).
3. Turn the Pressure/Vacuum Selector fully counterclockwise to the pressure position.

CH1 Function		
FUNCTION	TASK	MODE
None	Leak Test	Auto
Altitude	Switch Test	Manual (NC)
Airspeed	None	Manual (NO)



4. Select the **CH1 Function** screen. See section 8.6.1 to show this screen. Select **Airspeed > Switch Test** on this screen, and then the mode of the test. There are two test modes that can be used for non-accessible switch contacts:
 - **Manual (NC)** - Select to test a Normally Closed switch.
 - **Manual (NO)** - Select to test a Normally Open switch.
 The screen will have a different icon for each type of switch. Tap the **Tick** ✓ icon to show the next screen.

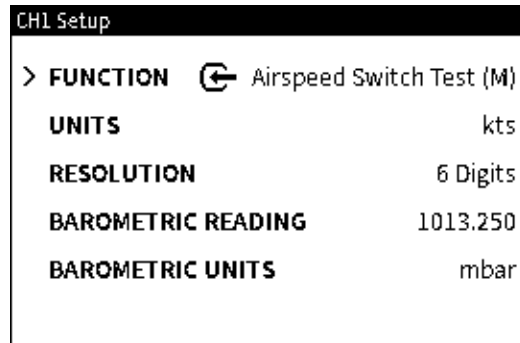



5. The display shows the **CH1 Setup** screen. The Function shows a manually controlled Airspeed Switch Test (M).

If you need different option values, select the row of the option. For example: tap on the **UNITS** row to show a screen of measurement units available. Tap in the related field to select the measurement unit.

To increase or decrease the shown accuracy of a measurement, tap on the **RESOLUTION** row. Select the wanted number of digits (4 to 7 digits) in the shown selection screen.

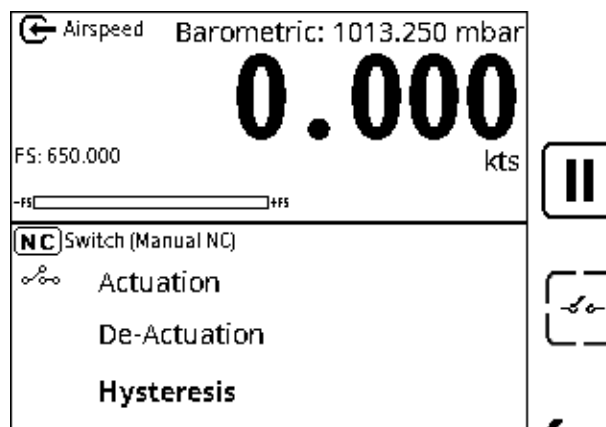

Tap the **Back**  icon to continue.



6. Tap the **Play**  icon (the icon changes to a **Stop**  icon).

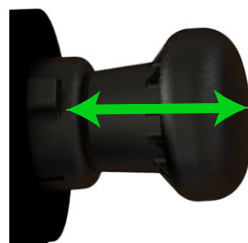

The screen shows a message that the pressure port must be open and the pressure reading stable. When these two conditions are good, tap the Tick icon  to continue.



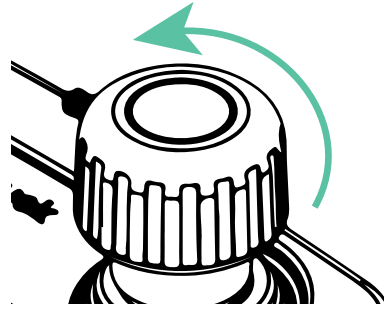

7. **Slowly** operate the pump handle until the switch operates, then tap the **Valve Open**  icon (Actuation) for a Manual (**NC**) valve test. If a Manual (**NO**) valve test is selected, tap the **Valve Close**  icon (Actuation).

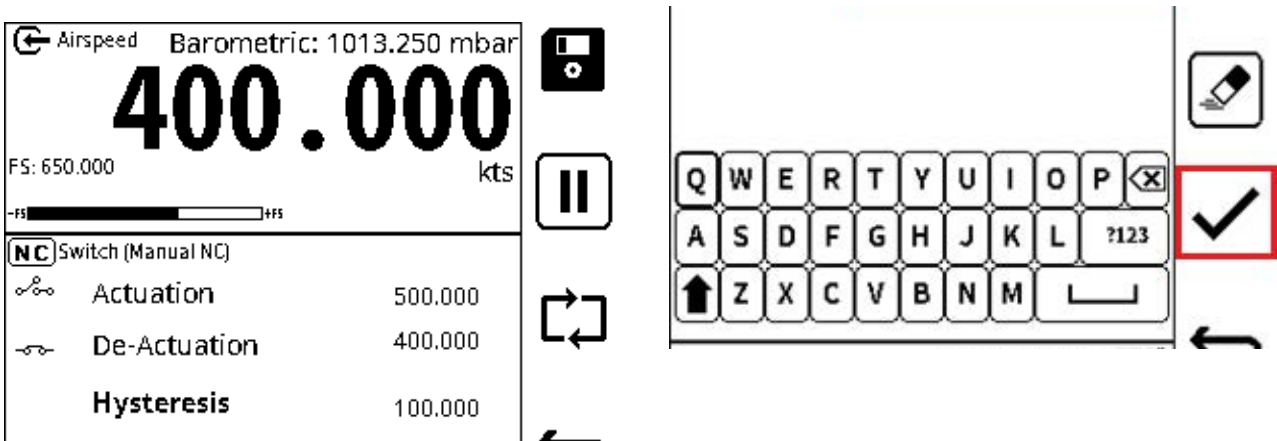

8. **Slowly** open the Release Valve (turn the valve counterclockwise). Let the altitude pressure decrease until the switch operates again.

Tap the **Valve Close**  icon (Actuation) for a Manual (**NC**) valve test. When a Manual (**NO**) valve test is selected, tap the **Valve Open**  icon (Actuation) switch icon to make a record of the airspeed at which the switch operates.



9. The screen will show the Actuation and De-actuation airspeed and Hysteresis value. Select the **Save**  Softkey to save the test data if wanted. An option will be available to do the test again: tap the **Repeat**  icon.

The default result file name will be the instrument's date of the test and the time (HH:MM:SS). This can be renamed if necessary. Select the **Tick** Softkey to confirm the Result file name and complete the save operation.

If the results are saved, the test details will be erased, and the test will be available to be done again.

If the results are not saved, a new test cycle can be set up, ready to operate.

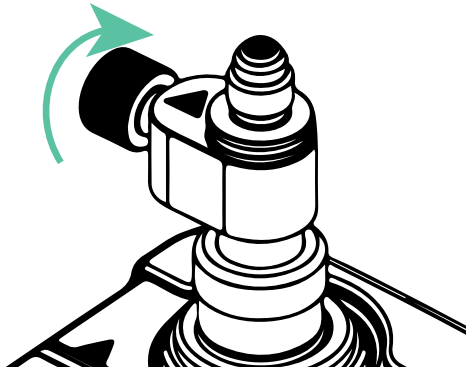

10. **Slowly** turn the Let-down Valve counterclockwise to make the system pressure go to ground level. Continue to turn the Let-down Valve fully counterclockwise to open the valve.

9. External Sensors

9.1 PM700E

9.1.1 Overview

The PM700E external remote sensors extend the pressure measurement functionality of a DPI610E instrument. These sensors have pressure ranges from 25 mbar to 1400 bar, and are available in absolute, gauge and differential types. PM700E sensors are available for both commercial and hazardous area environments. A single DPI610E can be used with multiple individual remote sensors because all sensors hold their own calibration data.

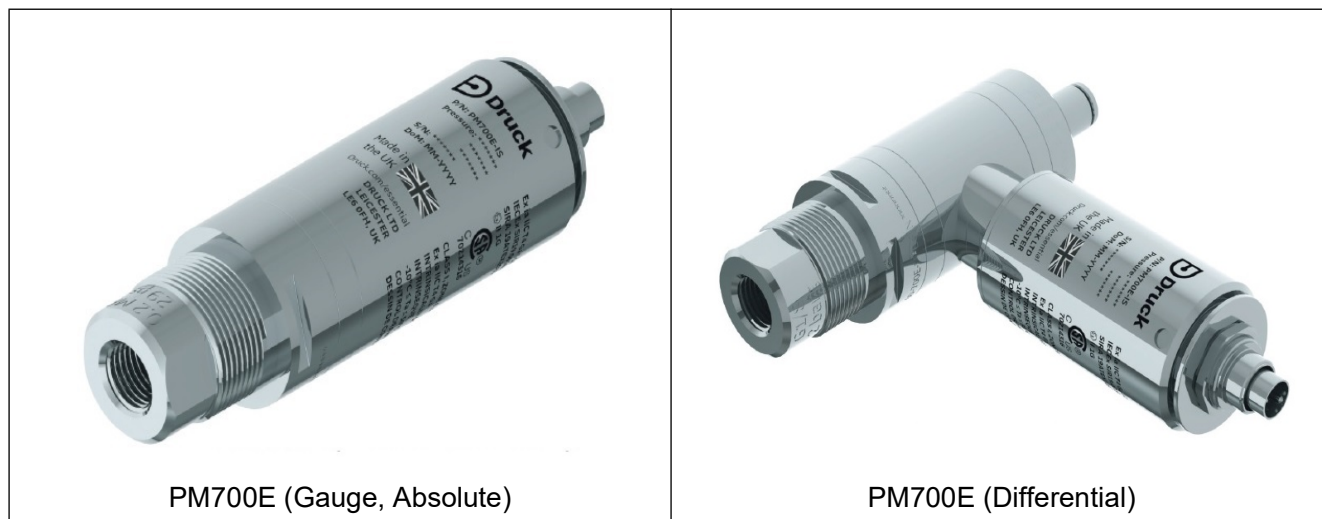

9.1.2 Media Compatibility

Be careful to obey media compatibility when using the PM700E. Sensors that measure up to 3.5 bar have exposed diaphragm construction. Sensors that measure 7 to 1400 bar have isolated diaphragms.

Table 9-1:

Pressure FS	Media Compatibility
0 to 3.5 bar	Non-condensing dry gases with 316L Stainless Steel, Pyrex, Silicon, Gold, Aluminum, Glass, Silicon Dioxide and RTV Adhesive
Differential sensor reference port	Non-condensing dry gases with 316L and 304 Stainless Steel, Pyrex, Silicon, Glass, Silicon Dioxide and RTV Adhesive
7 to 200 bar	316L Stainless Steel and Hastelloy C276
350 to 1400 bar	Inconel 625 and 17-4PH Stainless Steel

9.1.3 Setup

Each PM700E sensor includes a 2.9 m (9.5 feet) PM700E-CABLE. This cable is for the connection of the sensor to the “EXT SENSOR” port on the side of the DPI610E. Align the pin/slot arrangement at the female end of the cable connector with the male-connector end of the sensor. The cable connector will go into the socket with the minimum of force when it is correctly aligned. To complete the connection, rotate the locking collar until hand-tight. Align the male end of the cable to the port on the DPI610E and use the same method to lock the cable in position.



The DPI610E automatically senses when it connects to a PM700E sensor. The screen shows a 'Connected' status message for a short time in the status bar, when a successful connection of a compatible sensor occurs. The screen will also show an **External Sensor** icon  until the sensor is disconnected (see bottom left of screen image below). When the sensor is disconnected, the screen shows a 'Disconnected' message for a short time in the status bar and then the external sensor icon is removed.

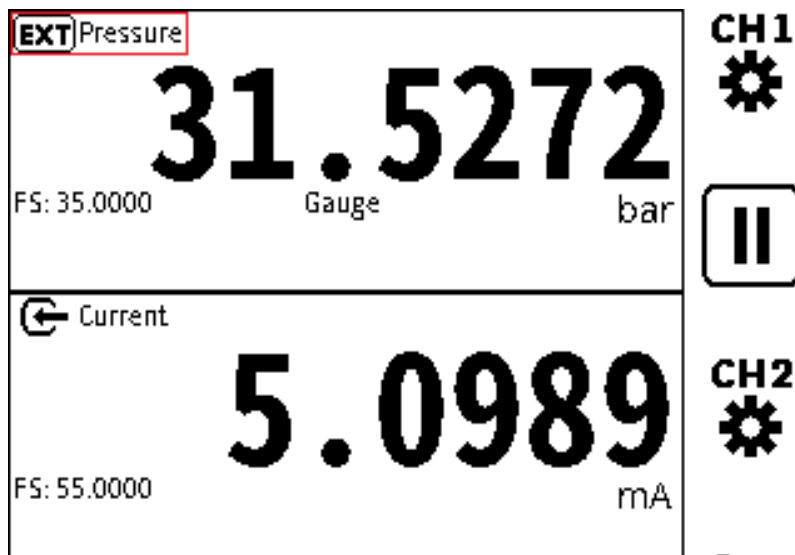

9.1.4 The Zero Function

Note: Set all gauge sensors to zero at the start of each day before use.



INFORMATION The Zero function is only available on gauge sensors. Absolute sensors can only measure atmospheric pressure. Refer to “The Zero Function” on page 57 for more information about the use of this function.

9.1.5 Available External Pressure Sensors

Only the external pressure sensors in Table 9-2 are compatible with the DPI610E type of instrument.

Table 9-2: External Pressure Sensors for DPI610E Range

Pressure Range	Gauge	Absolute	Differential	Barometric
25 mbar / 10 in H2O/ 2.5 kPa	008G	-	008L	-
70 mbar / 1 psi / 7 kPa	01G	-	01L	-
200 m bar / 3 psi / 20 kPa	02G	-	02L	-
350 m bar / 5 psi / 35 kPa	03G	03A	03L	-
700 m bar / 10 psi / 70 kPa	04G	04A	04L	-
1 bar / 15 psi / 100 kPa	05G	05A	05L	
750 - 1150 m bar / 11 - 17 psi / 75 - 115 kPa (Barometric)	-	-	-	05B
2 bar / 30 psi / 200 kPa	07G	07A	07L	-
3.5 bar / 50 psi / 350 kPa	08G	08A	-	-
7 bar / 100 psi / 700 kPa	10G	10A	-	-
10 bar / 150 psi / 1000 kPa	11G	11A	-	-
20 bar / 300 psi / 20 MPa	13G	13A	-	-
35 bar / 500 psi / 2 MPa	14G	14A	-	-
70 bar / 1000 psi / 7 MPa	16G	16A	-	-
100 bar / 1500 psi / 10 MPa	165G	165A	-	-
135 bar / 2000 psi / 13.5 MPa	17G	17A	-	-
200 bar / 3000 psi / 20 MPa	18G	18A	-	-
350 bar / 5000 psi / 35 MPa	-	20A	-	-
700 bar / 10 000 psi / 70 MPa	-	22A	-	-
1000 bar / 15 000 psi / 100 MPa	-	23A	-	-
1400 bar / 20 000 psi / 140 MPa	-	24A	-	-

9.1.6 How to set an External Pressure Sensor

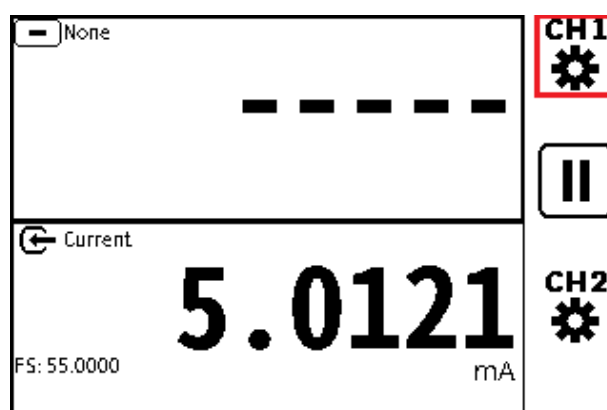

1. Select the wanted channel (CH1 in this example).

Chapter 9. External Sensors

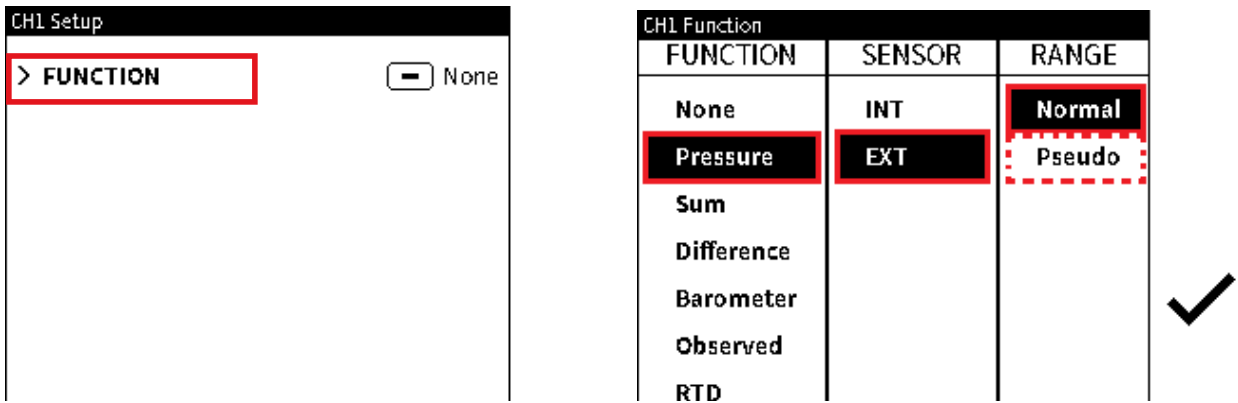

2. Select **FUNCTION** from the Channel **Setup** screen.
3. Select **Pressure > EXT > Normal** or **Pseudo**.

Select the **Tick** ✓ icon to make the selection and show the **Channel Setup** screen.

Refer to “Normal and Pseudo Pressure Range” on page 58 for more information about the use of Normal and Pseudo sensor values.

The **EXT** (External) pressure function is similar to that of the **INT** (Internal) pressure function. This is because the function supports all the Calibrator task functions that relate to internal pressure. For example: sensor zero, pseudo-range, leak test, switch test, relief valve.

If the **External Pressure** function is configured on a channel without a sensor connected, the screen shows the primary reading in that channel window as “- - - -”.

If the external sensor is disconnected while the function is in use, the screen will show an error message.

PM 700E External Remote sensors with firmware version DK481 2.00.00 and above, are available for use with the DPI610E. Sensor validation is automatically done when a new connection is detected.

If a channel is set for External Pressure and a sensor that is not compatible is sensed (for example a PM 700E sensor with firmware version less than 2.00.00), the screen will show a

warning message that the sensor is not compatible. The status bar will have this sensor icon  in it.



The readings from the sensor in the channel window of the screen will be as usual, but sensor calibration will not be possible with the DPI610E. All PM700E sensors etched with a part number ending in “-3” have the correct firmware installed for full supported use on the DPI610E.

If a channel is set for External Pressure and a sensor that is not compatible is detected, the screen will show a warning message, that the connected sensor is not compatible. The screen will also show the sensor icon  in the status bar.

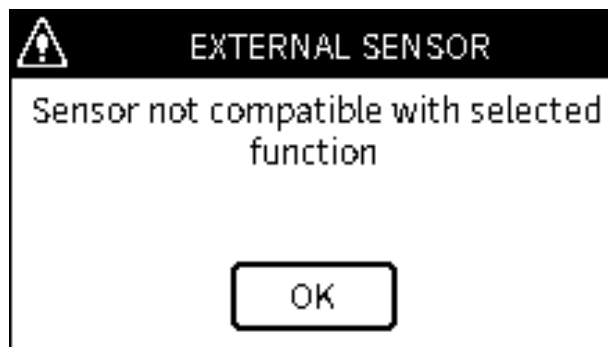

When a PM 700E sensor is connected or when the DPI610E is energized with the sensor connected, it automatically examines the calibration status. Each sensor has a calibration due-date. The automatic examination finds the number of days available for the use of the sensor before this due-date. If less than 30 days are left, the screen shows this message.

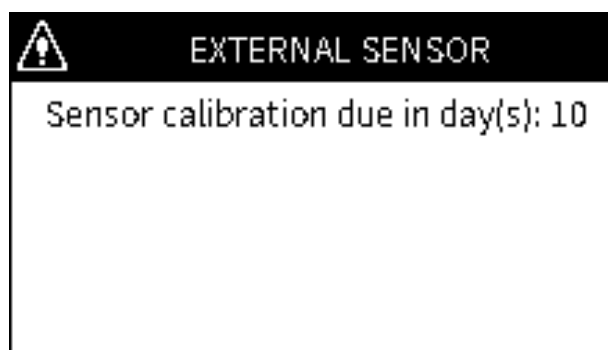

If the days left is 0 or less, the screen will show a message that calibration is necessary. This occurs when the sensor in a port is sensed, either at power up or when the DPI610E is already in operation. Also, a message text "CAL DUE" will permanently be in the status bar until the sensor is disconnected or the sensor has been calibrated.

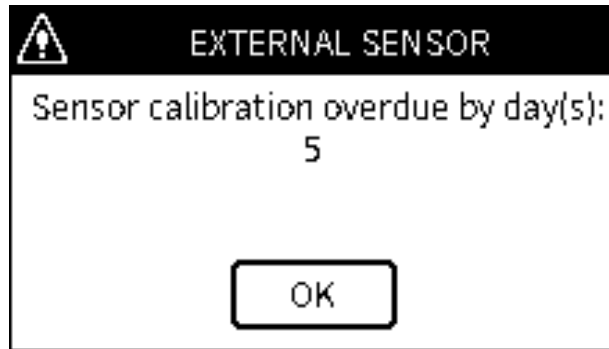

9.2 RTD Probe and Interface

9.2.1 Overview

The DPI610E can be set to show readings from the RTD-INTERFACE (which is a remote adapter interface) and the RTD-PROBE (or any other compatible probe). Temperature measurements can be shown in resistance or temperature measurement units. The RTD-PROBE and RTD-INTERFACE are available for use in safe and hazardous areas. The RTD-PROBE has a 15 cm (6”) class-A PT100 probe. The type names are as follows:

Table 9-3:

	Safe Area	Hazardous
RTD Interface	RTD-INTERFACE-485	RTD-INTERFACE-IS
RTD Interface with probe	RTD-PROBE-485	RTD-PROBE-IS

Use the supplied 2.9m (9.5 feet) cable to connect the RTD-PROBE/RTD-INTERFACE to the DPI610E. The RTD-INTERFACE is supplied with a field-rewireable M12 connector, that lets connections be done by the use 2,3 or 4-wire RTDs.



9.2.2 Temperature Considerations

Think carefully when the RTD-INTERFACE and the RTD-PROBE (or specialist RTD probes) are to be used. The environment and process temperatures must be compatible with the specified limits for each RT component. The table below gives these limits.

Table 9-4:

	Item	Temperature Range
Measuring temperatures	IO-RTD-PRB150 (Supplied Probe)	-5°C to 200°C (when used with an applicable extension cable)
	RTD-INTERFACE (BODY)	-10°C TO 50°C
	RTD-PROBE	-10°C TO 50°C when directly pushed into the RTD-INTERFACE -10°C TO 50°C when supplied cable is used
	SPECIALIST RTD PROBE (Not supplied by Druck)	The capability of the RTD-INTERFACE (resistance range) with a suitable extension cable and suitable probe, is 0 to 400Ω (this is equivalent to -250°C to +650°C for a PT100 probe).

9.2.3 Setup

Connect the RTD-PROBE to the RTD-INTERFACE. When a direct connection is necessary, turn the probe end into the connection on the RTD-INTERFACE. The 2m (6.6 feet) M12 extension cable (IO-RTD-M12EXT) can be used to increase the connection distance between the RTD-INTERFACE and the RTD-PROBE. If a compatible RTD (not supplied by Druck) is used, use the M12 field-wireable connector (IO-RTD-M12CON) to connect the RTD probe to the RTD-INTERFACE.

Note: The pin numbers are printed on the rear of the connector body.

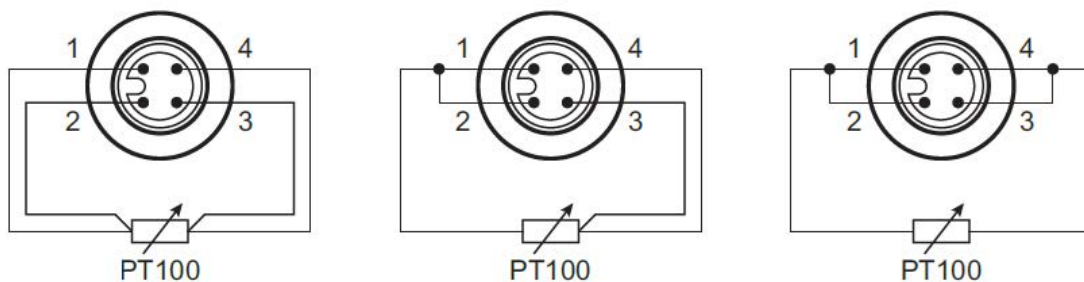

RTD M12 Connector Pinout

With the supplied RS485 sensor cable, align the pin/slot arrangement at the female end of the cable connector with the male-connector end of the sensor. The cable connector, when it is correctly aligned, will go in with the minimum use of force. To complete the connection, turn the swivel connector fully until hand-tight. Align the male end of the cable to the port on the DPI610E and use the same method to tighten into position.

Chapter 9. External Sensors



The DPI610E automatically detects any connection to the RTD-INTERFACE. After the successful connection of a compatible sensor, the screen shows a “Connected” text message for a short time in the status bar. The screen also permanently shows the external sensor icon  until the sensor is disconnected. When the sensor is disconnected, the screen shows a “Disconnected” text message for a short time in the status bar. The external sensor icon will also be removed.

If a channel is set with a RTD function, without a sensor connected, the channel window will show the primary reading as “- - - -”. If the external sensor is disconnected while the function is in use, the screen can show an error message. After successful connection, the full-scale value of the RTD probe is shown and the RTD probe type.

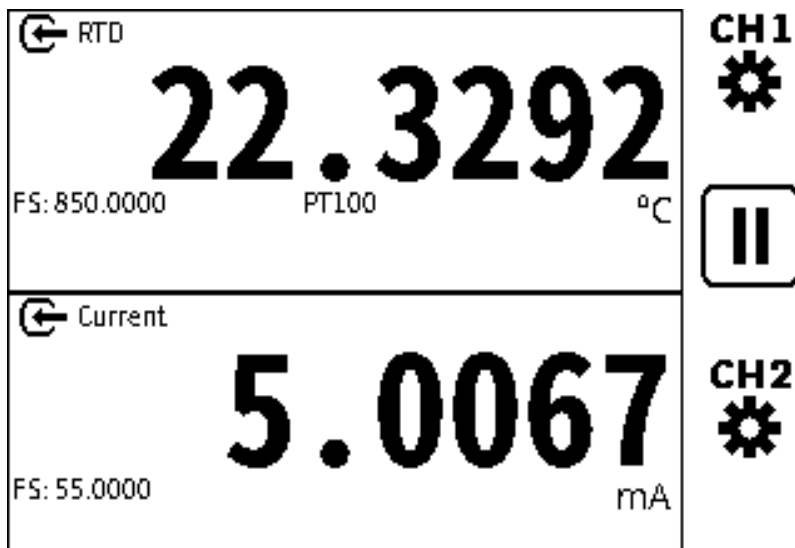

9.2.4 Setup of a Channel for a RTD Sensor

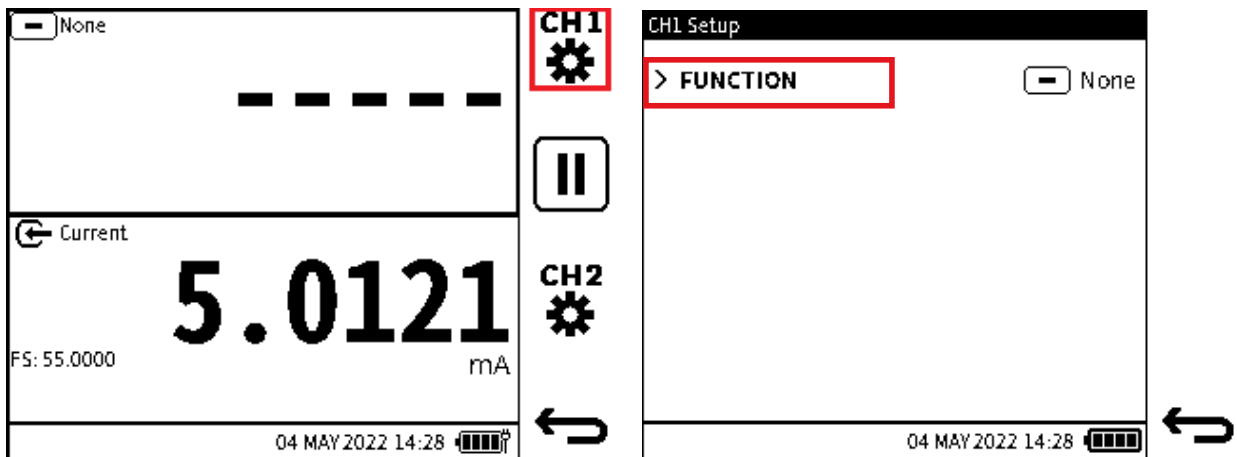

1. Select the wanted channel (CH1 in this example).
2. Select **FUNCTION** from the Channel **Setup** screen.

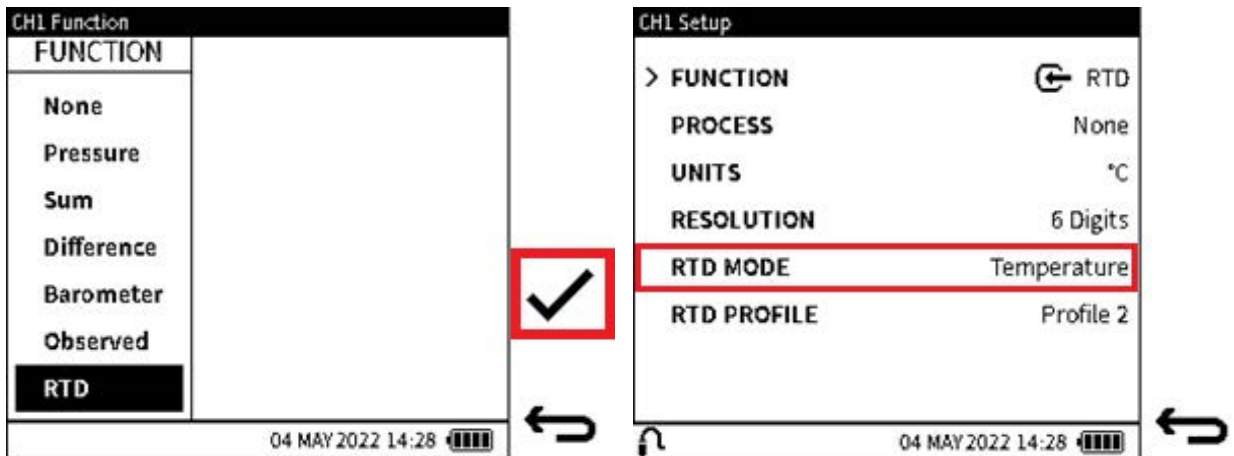

3. Select **RTD** and select the **Tick** icon to make the selections and show the **Channel Setup** screen.
4. To set the RTD measurement as resistance or temperature, select the **RTD Mode** option from the **CH Setup** screen and push the **Enter** key in the Navigation Pad.

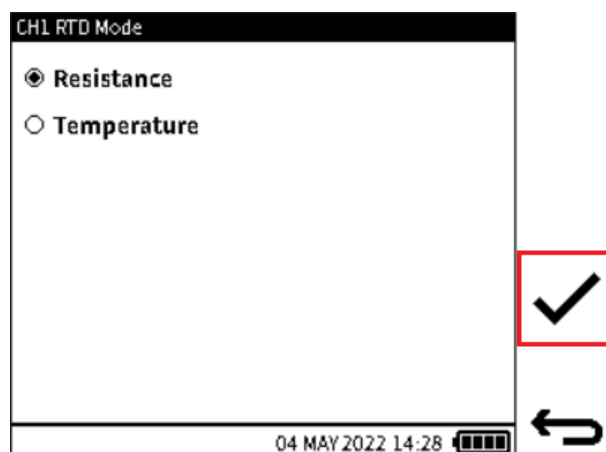

Chapter 9. External Sensors

5. Tap the options for Resistance or Temperature.

Select the **Tick** icon to set the selected **RTD MODE** and to go back to the channel **Setup** screen.

The **RTD Profile** can now be selected if necessary.

9.2.5 RTD Profiles

The screen shows the full-scale value of the RTD probe and the RTD probe type. When you select the RTD function, it can be necessary to set the wanted RTD profile:

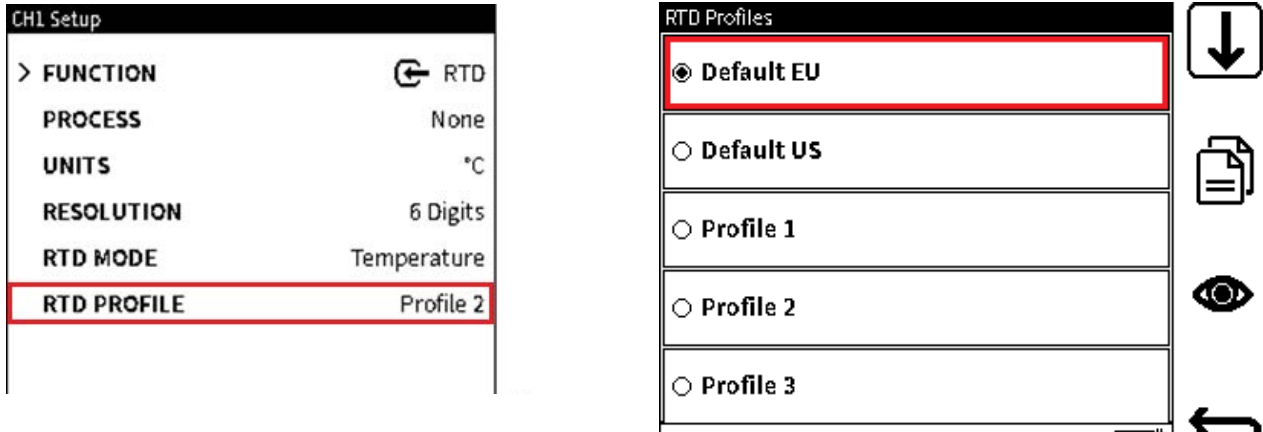

1. Tap on the saved RTD profile field in the **Channel Setup** screen.
2. Use the Navigation Pad to select the **RTD Profile** row and push the **ENTER** button to show a list of available profiles.

The set default profile is the “Default EU” option or PT100-PA-392. This uses the European standard (DIN/IEC 60751) for Class A Platinum RTDs. There is also a “Default US” or PT100-PD-385, that uses the American standard. The Default EU and Default US profile options are pre-defined and cannot be changed or erased.

Eight Custom profiles can be made. Enter into the available user **Profile** files, the necessary coefficients, temperature range and label.

Tap on the wanted profile to select it. Tap on the **View**  icon to look at or change the coefficients and parameters in the profile. An alternative method is to use the **UP/DOWN**

Navigation Pad buttons to select the wanted profile and push the **View** Softkey to see or change the coefficients and parameters in the profile.

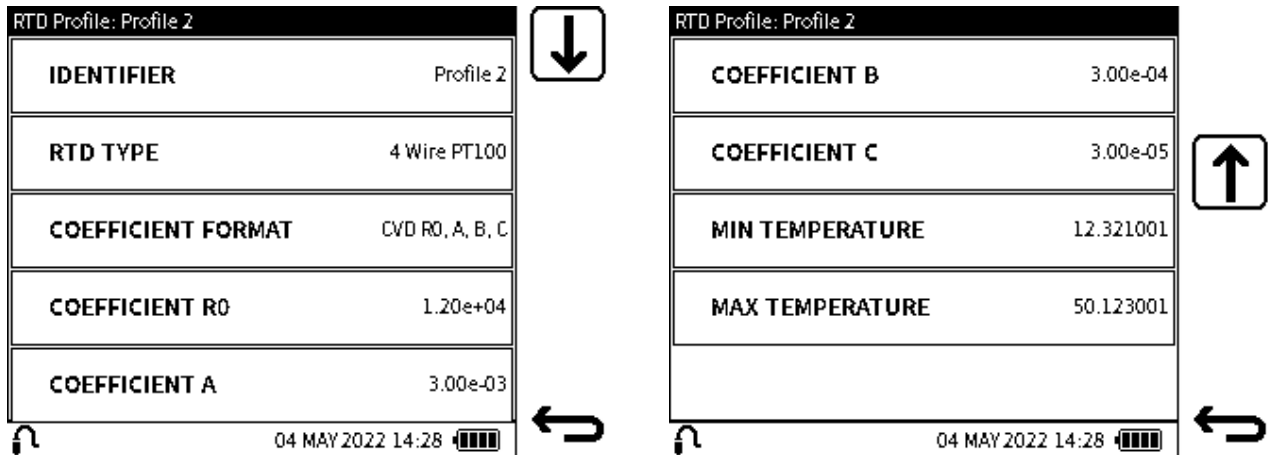

To change selected parameters:

1. Tap on the value field of the wanted parameter.
2. Use the **UP/DOWN** buttons to select the wanted parameter to be changed. Push the **Enter** button to go into the edit screen of the parameter. Push or tap the **Tick** icon Softkey to accept and save the new values.

It is possible to make a copy of the parameters saved in a profile and put it in a custom profile. Note the Default EU and Default US profiles cannot be changed but copies can be made and put into one of the custom profiles. Custom profiles are saved in the RTD-INTERFACE not on the DPI610E.

Table 9-5: RTD Profile parameters

Parameter	Description
Identifier	A unique name for the custom profile
RTD Type	Select from 2, 3, 4 wire RTD setup. 4-wire is the default value.
Coefficient Format	Select from Callendar-Van Dusen equation formats or use the ITS90 equation format.
Coefficient R0	Resistance at 0°C
Coefficient 1 (a, A, Alpha)	First coefficient value
Coefficient 2 (b, B, Beta)	Second coefficient value
Coefficient 3 (c, C, Delta)	Third coefficient value
Min. Temperature	Minimum temperature
Max. Temperature	Maximum temperature

When all parameter fields are filled, use the **Back** Softkey to go back to the **RTD Profile** screen.

Chapter 9. External Sensors

9.2.5.1 To copy a RTD profile

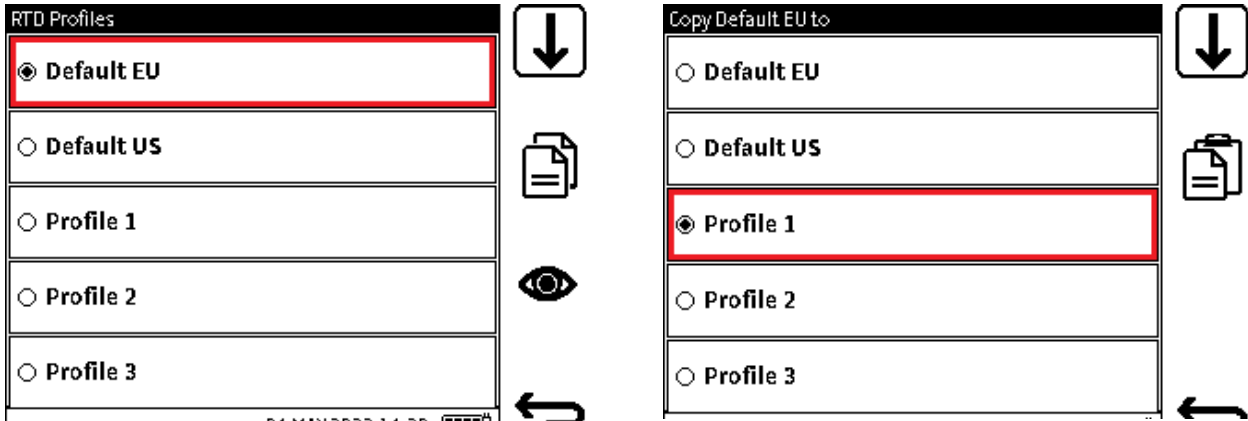

1. Select the wanted profile.
2. Tap the Touchscreen or push the **Copy**  icon Softkey and then select the wanted destination profile, for example: Profile 1.

9.2.5.2 RTD Units

When in Resistance mode, the only measurement units available to select are: ohms (Ω) and Custom units. In Temperature mode, select from $^{\circ}\text{C}$, $^{\circ}\text{F}$ or Custom units. Refer to Section 6.4.6 on page 90 for information about Custom units.

9.3 The ADROIT Sensor

9.3.1 Overview

The Druck ADROIT 6000 Series is a family of high performance, digitally-compensated industrial pressure sensors that can go in spaces that are as small as 19 mm wide. ADROIT sensors can measure pressure ranges from 70 mbar to 350 bar (1 to 5,000 psi), with electrical output options in either Voltage or Current (4 to 20 mA).



To calibrate ADROIT sensors without the DPI610E, it is necessary to use the Druck ADROIT PC application, together with the ADROIT interface box and an applicable calibrated pressure source.

The DPI610E is an all-in-one solution for the calibration of ADROIT sensors: thus, a PC, interface device, and a pressure source are not necessary. The DPI610E with its One-Wire Interface technology, can share data with ADROIT sensors.

9.3.2 Setup of an ADROIT Sensor

You must select the One Wire Interface (OWI) mode for the DPI610E and ADROIT sensor to work with each other. You will need the following information, which will be on a label on the sensor:

- Sensor pressure range. For example: 0 to 10 bar g.
- Electrical Output option. For example: 0 to 10 V.

CH2 is the primary electrical channel on the DPI610E and thus the channel that provides **ADROIT** functionality.

CH2 Function 1/2		
FUNCTION	DIRECTION	POWER
None	Measure	Off
Current	Source	24V
Voltage		10V
Millivolts		
Pressure		
Barometer		
Observed		





1. In the **CH2** setup screen, select either the **Current** or **Voltage** function: the selection will relate to the electrical output function of the sensor. Then select the **Measure** Direction and **24 V** Loop options.
2. Select  to save and show the **CH2** setup menu.



CH2 Sensor Configuration	
<input type="radio"/> Standard	
<input checked="" type="radio"/> ADROIT	





3. The **CONFIGURATION** option will then appear on the **CH2 Setup** screen. Select this option to show the **CH2 Sensor Configuration** screen: the default selection Configuration option is **Standard**.



Chapter 9. External Sensors

- The screen will show the **Configuration** setup  Softkey. Select this Softkey to see or change the setup parameters.
- After the selection of the  icon, wait while the system updates its values, then the screen shows the **Configuration: ADROIT** screen.

Configuration : ADROIT	
> INPUT MIN RANGE	0.000
INPUT MAX RANGE	10.000
INPUT UNITS	bar
OUTPUT MIN RANGE	4.000mA
OUTPUT MAX RANGE	20.000mA
Rseries	0.000Ω
Vdiode	0.500V



This screen has several options:

- INPUT MIN RANGE** - the minimum pressure range value of the ADROIT sensor. The default value is 0 bar (or equivalent in a user-selected pressure measurement unit).
 - INPUT MAX RANGE** - the maximum pressure range value of the ADROIT sensor. The default value is 10 bar (or equivalent in a user-selected pressure measurement unit).
 - INPUT UNITS** - measurement unit of input.
 - OUTPUT MIN RANGE** - the minimum electrical output range value of the ADROIT sensor. The default value for current output sensors is 4 mA and the default value for 3-wire voltage output is 0 V.
 - OUTPUT MAX RANGE** - the maximum electrical output range value of the ADROIT sensor. The default value for current output sensors is 20 mA and the default value for 3-wire voltage output is 5 V.
 - Rseries** - the series resistance of the wiring (cable) length between the ADROIT sensor and the electrical ports where it stops. Default value is 0 ohm.
 - Vdiode** - the voltage-drop through the resistor or resistance in the circuit. The default value is 0.5 V.
- Set the sensor input and output parameters shown on the sensor so that they are the same as on the sensor label. Select the **Tick**  Softkey to save and show the sensor configuration menu.
 - Select the **Back**  button on the **CH2 Setup** screen to show the Calibrator screen.
 - Make sure that the ADROIT sensor is correctly connected to the pressure port on the DPI610E.



Use applicable adapter fittings if the pressure connector thread is not the same as the DPI610E Test Port quick-fit connector. The adapter fittings must be rated to 35 barg. Use the procedure in Section 2.1.5, “To Attach the Device Under Test,” on page 20 to attach the ADROIT sensor to the Test Port.

Push the plugs of the electrical leads from the ADROIT sensor into the correct electrical sockets on the DPI610E (See **Current Measure** with 24 V page 65 or **Voltage Measure** with 24 V electrical connection diagrams on page 77).

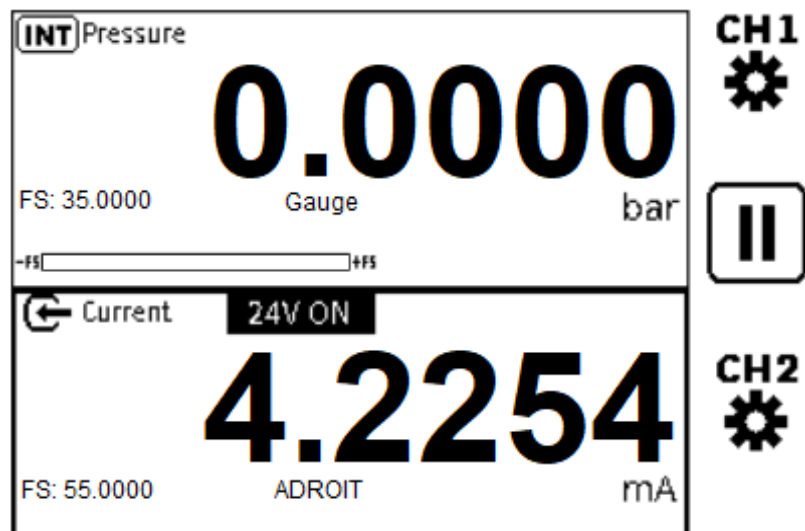

Make sure that the electrical reading and data in the **CH2** are correct: the measured value will be the minimum range value when the pressure is open to atmosphere.

9.3.3 ADROIT CALIBRATION

On the Dashboard push the **Settings**  Softkey and then select the **ADVANCED** menu option. Enter the correct PIN to get access to the **ADVANCED** menu (for more information, refer to “ADVANCED” on page 40).

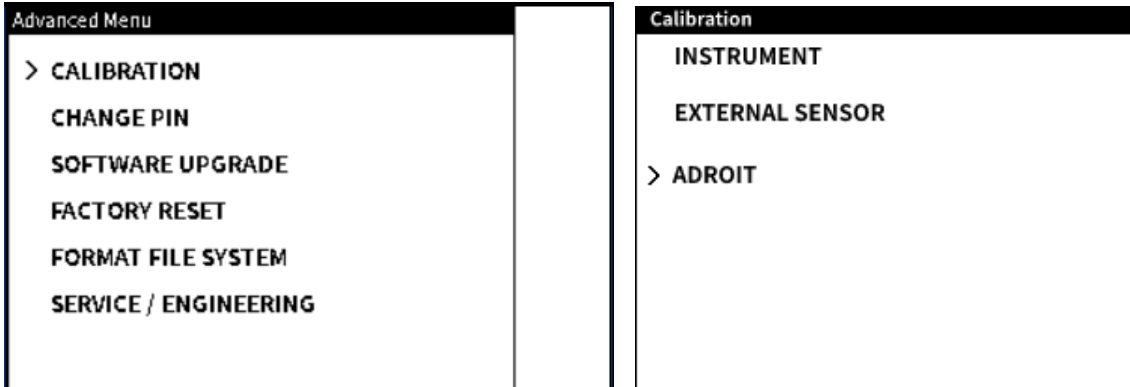

1. Select **CALIBRATION** on the **Advanced Menu** screen.
2. Select **ADROIT** on the **Calibration Menu** screen. Wait for the display to show the **Adroit Calibration** screen.

Note: The screen will only show the **EXTERNAL SENSOR** option when an external sensor attaches to the EXT.SENSOR socket of the DPI610E.

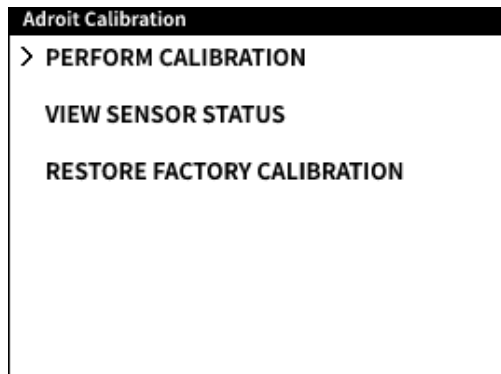

3. There are three calibration options for an ADROIT sensor:
 - **PERFORM CALIBRATION** - Calibrate the sensor.
 - **VIEW SENSOR STATUS** - See ADROIT pressure sensor data.
 - **RESTORE FACTORY CALIBRATION** - Use the factory (default) calibration values.

9.3.4 PERFORM CALIBRATION

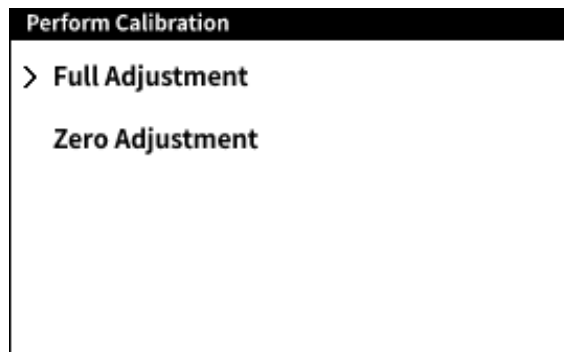

Select the **PERFORM CALIBRATION** option to get to the calibration options. There are two types of adjustments available:

- **Full Adjustment** - this is a 2-point calibration adjustment of the sensor through the zero (or minimum full-scale) and the positive full-scale pressure range.

- **Zero Adjustment** - this is a 1-point calibration adjustment of the sensor at zero pressure.

9.3.5 FULL ADJUSTMENT CALIBRATION

Select **Full Adjustment** from the **Perform Calibration** menu screen. Make sure that the sensor data on the **Configuration: Adroit** screen are the same as that of the sensor to calibrate. Refer to page 144 for a description of the contents of this screen.

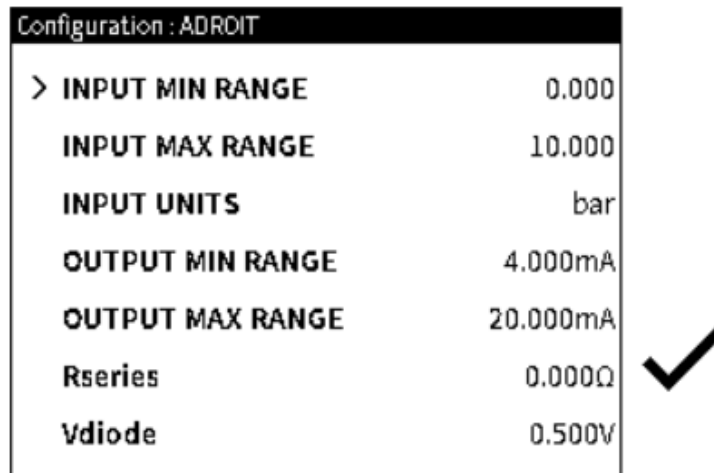

Change the sensor data on the screen if necessary.

Select the **Tick** icon to go to the next step of the calibration procedure.

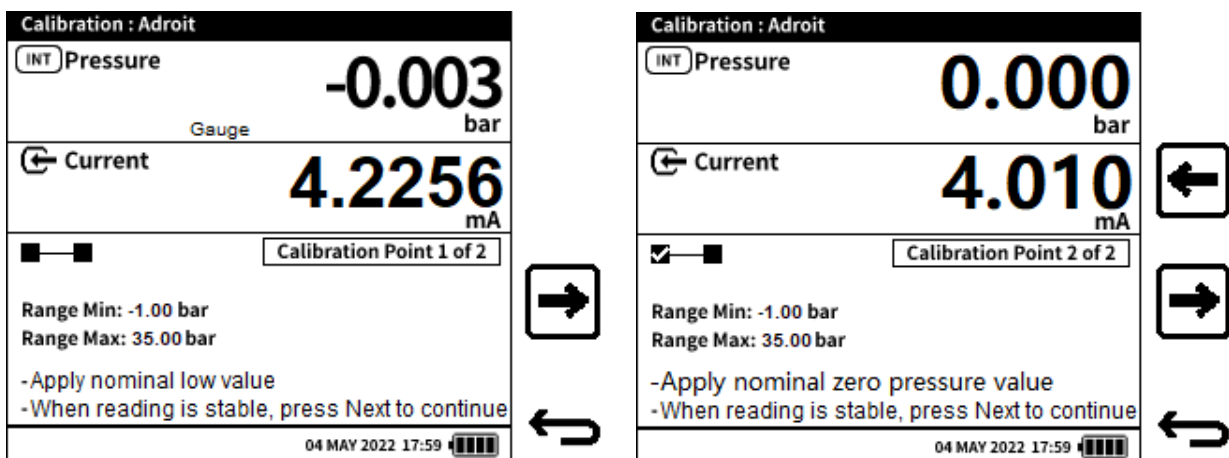

1. To start the full calibration adjustment, apply a nominal zero or low pressure to the sensor. Use the DPI610E pump and/or Volume Adjuster to apply pressure.
When the pressure value is stable, push the **Next** Softkey to move to Calibration Point 2.
2. At Calibration point 2, apply the full-scale pressure of the sensor. Use the DPI610E pump and/or Volume Adjuster to apply pressure. When the pressure reading is stable, push the **Next** Softkey to continue.



3. **For Current Output sensors only (Ignore this step for Voltage Output sensors).**

The screen shows a message window that has the instruction to vent the system to atmosphere. Open the pressure release valve slowly until the system is fully vented before the selection of the **OK** button.

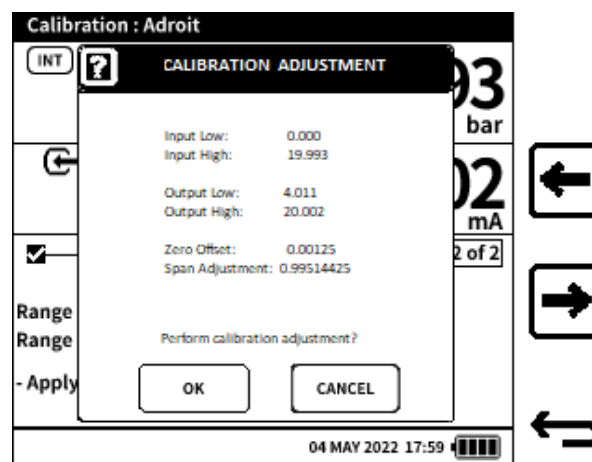



4. The display shows the **CALIBRATION ADJUSTMENT** window. Make sure that the values shown are correct before selection of the **OK** button. The functions of the parameters are:
- **Input Low** - the Input low pressure applied by the DPI610E to the sensor at Calibration Point 1.
 - **Input High** - the Input high (or positive full-scale) pressure applied by the DPI610E to the sensor at Calibration Point 2.
 - **Output Low** - the electrical output value from the sensor that the DPI610E measured at Calibration Point 1.
 - **Output High** - the electrical output value from the sensor that the DPI610E measured at Calibration Point 2.

The system calculates the **Zero Offset** and **Span Adjustment** values from these shown values.

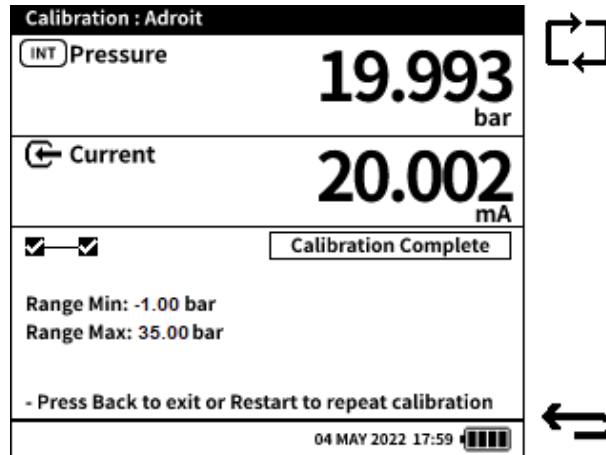
If these values are not acceptable, select **Cancel** to go back to the calibration procedure.



5. Select **OK** to complete the calibration adjustment of the sensor. The status box shows the **Calibration Complete** message. There are three selections available:
 -  **VERIFICATION** Softkey takes you to the **Verification** screen.
 -  **RESTART** Softkey lets the calibration procedure be started again if a repeat calibration is necessary.
 -  **BACK** Softkey stops the calibration procedure and takes the user to the **Perform Calibration** menu screen.

9.3.6 ZERO ADJUSTMENT

When **Zero Adjustment** is selected from the **Perform Calibration** menu screen (see page 146), make sure that the sensor data on the **Configuration: Adroit** screen are the same as that of the sensor to be calibrated. Refer to page 157 for more information about the contents of this screen.

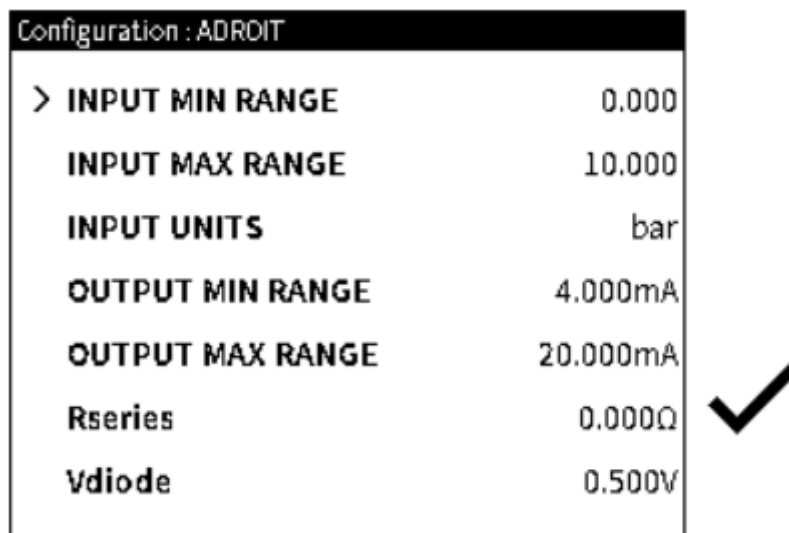

Change the sensor data on the screen if necessary.

Select the **Tick**  icon to go to the next step of the calibration procedure.

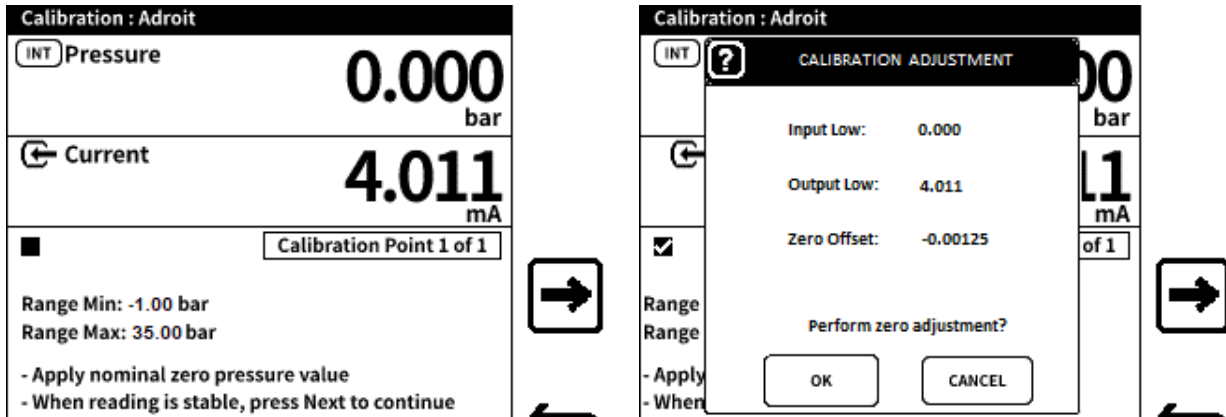

1. To start the zero calibration adjustment, apply a nominal zero or low pressure to the sensor. Use the DPI610E pump and/or Volume Adjuster to do this.

When the pressure value is stable, push the **Next**  Softkey to continue.



2. The screen shows the **CALIBRATION ADJUSTMENT** window. Select **OK** to complete the calibration adjustment of the sensor. Select **Cancel** to return to the **Calibration** screen. Make sure that the values shown are correct before the selection of the **OK** button. The functions of the parameters are:

Output Low - the electrical output value from the sensor, that the DPI610E measured at Calibration Point 1.

From these two values the system calculates the Zero Offset value.

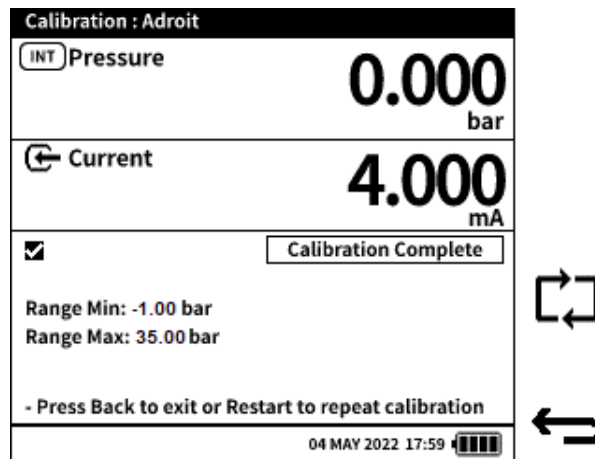
If these values are not satisfactory, select the **CANCEL** button, and do the calibration procedure again.



3. When **OK** is selected, the status box shows the **Calibration Complete** message. There are three selections available:
 -  **VERIFICATION** Softkey takes you to the **Verification** screen.
 -  **RESTART** Softkey lets the calibration procedure be started again if a repeat calibration is necessary.
 -  **BACK** Softkey stops the calibration procedure and takes the user to the **Perform Calibration** menu screen.

9.3.7 VIEW SENSOR STATUS

This menu gives information about the ADROIT sensor model and serial number.

Adroit Status	
SENSOR	ADROIT6200
SERIAL NUMBER	012345

9.3.8 RESTORE FACTORY CALIBRATION

Before delivery, the factory calibration values are saved in the internal memory of the sensor. If it is necessary, the sensor can have these factory settings used again. Use the **RESTORE FACTORY CALIBRATION** function to do this.

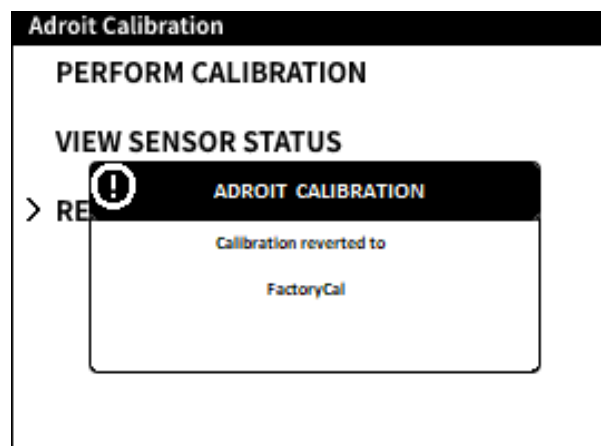

Select **RESTORE FACTORY CALIBRATION** from the **Adroit Calibration** screen.

Select **OK** on the popup box to use the restore operation: this operation can take several seconds before it shows the screen as shown.

10. Data Log

The **Data Log** function records instrument readings (measured or sourced) so that they can be analyzed. The following options are available under the **Data Log** menu:

Option	Description
Setup	Set up Data Log
Files	Look at and delete data log files

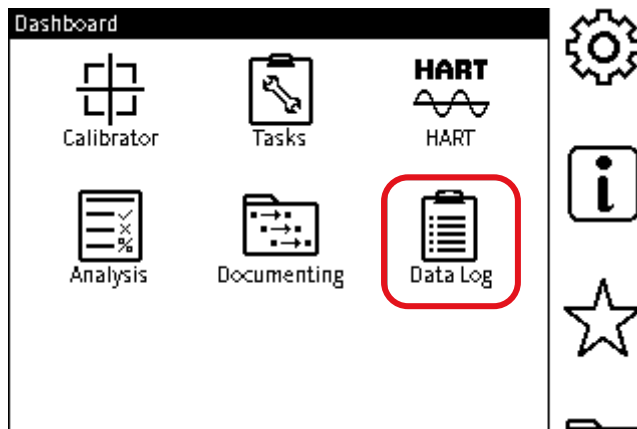

To get access to Data Log, select **Data Log** from the Dashboard.

10.1 Data Log Setup Menu

The following options are available under the **Setup** menu:

Option	Description
OUTPUT	Output to File or live output to USB
FILENAME	Change file name
TRIGGER	Set Data Log trigger
TIME INTERVAL	Set Data Log time interval
LOG DURATION	Set Log duration
DATA POINTS	Set Data Log points

TIME INTERVAL, **LOG DURATION** and **DATA POINTS** are only listed in the **Data Log Setup** menu when **TRIGGER** is set to **PERIODIC** (See Section 10.2 on page 155).

10.1.1 How to Set the Data Log Filename

To set the Data Log filename:

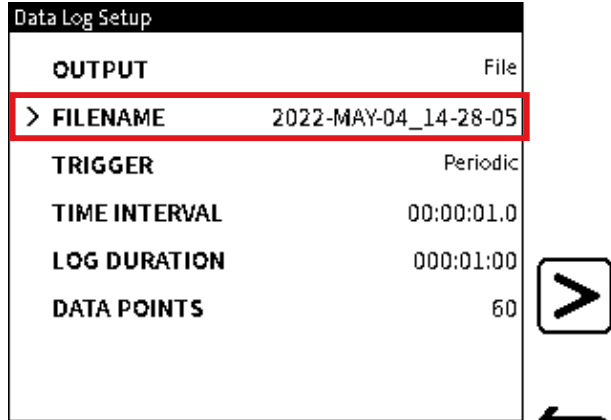
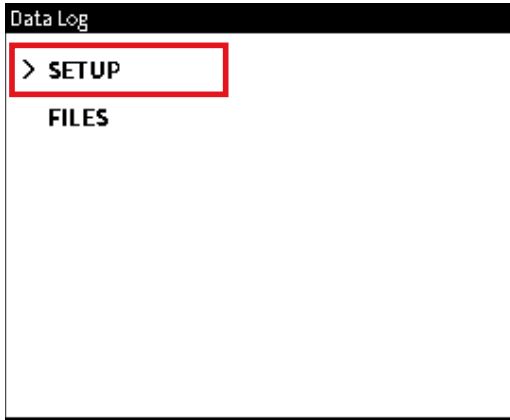

1. Select **SETUP** from the **Data Log** screen.
2. Select **FILENAME** from the **Data Log Setup** screen.

Note: **TIME INTERVAL**, **LOG DURATION** and **DATA POINTS** are only given on the **Data Log Setup** screen when **TRIGGER** is set to periodic.

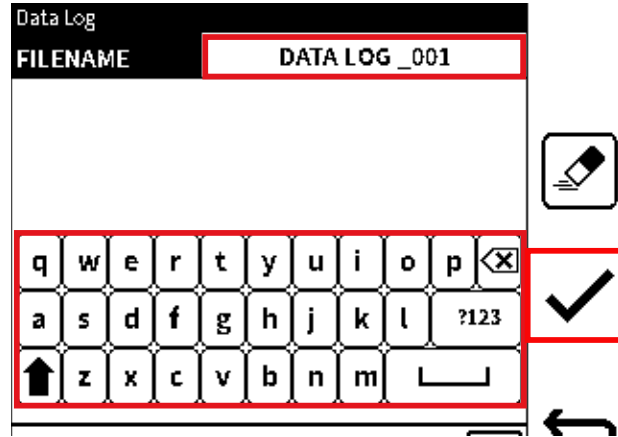

3. Select the **Eraser** icon to erase the default data log file name.
Note: The default data log file name format is: [YYYY-MMM-DD_HH-MM-SS].
4. Use the screen keypad to enter the new **Data Log** file name.
Note: Only a maximum of 20 characters and symbols are available.
Select ✓ to set the new file name.

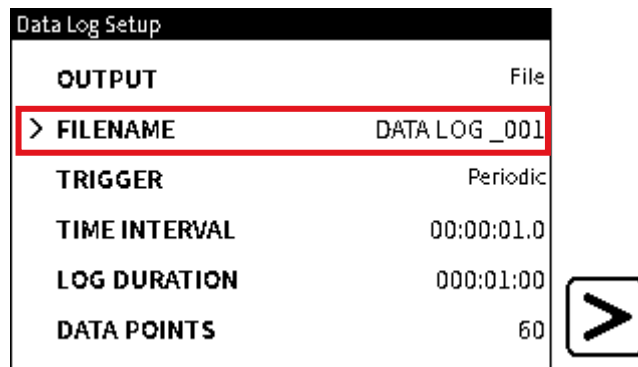

5. Make sure that the new file name is in the **Data Log Setup** screen.

Note: **TIME INTERVAL**, **LOG DURATION** and **DATA POINTS** are only given on the **Data Log Setup** screen when **TRIGGER** is set to Periodic.

10.2 TRIGGER Menu

The **TRIGGER** menu lets the user select the type of **Data Log Trigger** mode. The following options are available under the **TRIGGER** menu:

Option	Description
KEY PRESS	Data Log started by a key push
PERIODIC	Periodic Data Log

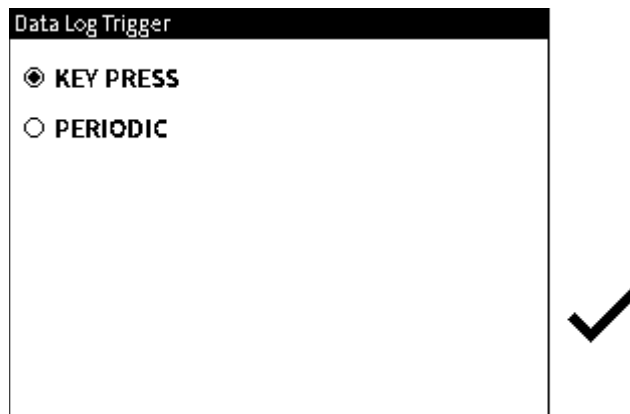

Figure 10-1: Data Log Trigger Menu

When you select **KEY PRESS**, no more settings will be necessary to set up the Data log. Tap the **Tick** ✓ icon to go back to the **Data Log Setup** screen. Select **FILENAME** if a new name for the data log file is necessary (See Section 10.1.1 on page 153 for the procedure). Refer to Section 10.4 on page 158, to continue the instructions for **KEY PRESS** data logging.

When the **PERIODIC** trigger mode is selected, more recording options become available that can be set.

10.3 Periodic Trigger Options

The options **TIME INTERVAL**, **LOG DURATION** and **DATA POINTS** are only available for use when **PERIODIC** is the trigger mode to make data result records.

10.3.1 TIME INTERVAL

When you select a **Periodic** trigger mode, the option to set the Periodic interval is available from the **Data Log Setup** screen. The interval period is how long each data point is logged and it is shown in the format of HH:MM:SS.S. The time interval range is from 00:00:00.2 to 23:59:59.9. Functions set in the Calibrator channels have an effect on the minimum interval available. See table below.

Function	Minimum Interval (HH:MM:SS.S)
Internal Barometer	00:00:05.0
Internal Pressure	00:00:00.2
External Sensor (Pressure and RTD)	00:00:00.2

Function	Minimum Interval (HH:MM:SS.S)
Current / Voltage / Millivolt Measure	00:00:00.5
Current Source	00:00:01.0
HART	00:00:00.5

10.3.1.1 How to Set the TIME INTERVAL

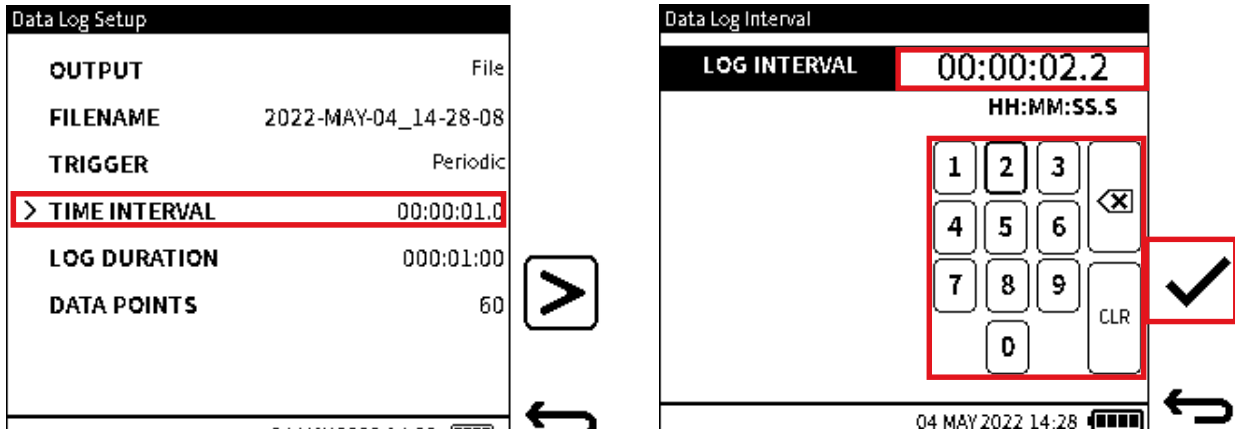

1. Select **TIME INTERVAL** from the **Data Log Setup** screen.
2. Use the keypad to set the **LOG INTERVAL**. Select ✓ to make the selection.

Note: The time interval must be entered in the [HH:MM:SS.S] format in the range [00:00:01] to [23.59.9].

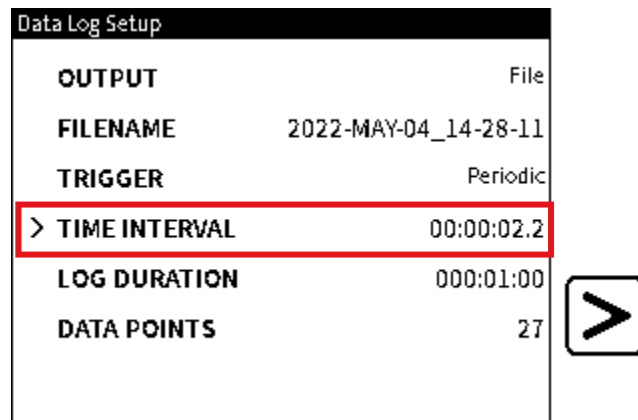

10.3.2 LOG DURATION

After selection of the Periodic trigger mode, the option to set the Data Log Duration becomes available from the **Data Log Setup** screen. The log duration sets the period through which the logging will occur, from start to end. Its format is HH:MM:SS. The supported time interval range is between 00:00:01 to 999:59:59.

Note: The time interval value must always be less than the **LOG DURATION** value.

10.3.2.1 How to set the LOG DURATION

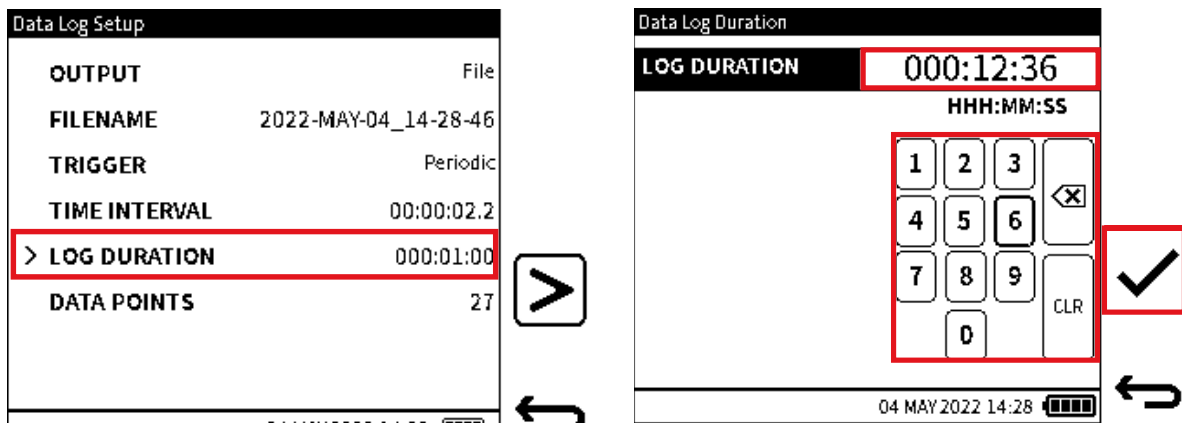

1. Select **LOG DURATION** from the **Data Log Setup** screen.
2. Use the on-screen keypad to set the **LOG DURATION** value.

Select ✓ to make the selection.

Note: The time interval must be entered in the [HHH:MM:SS] format in the range [000:00:01] to [999.59.59].

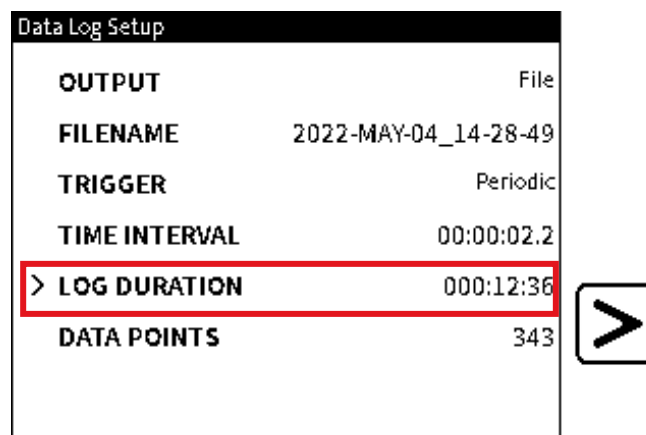

10.3.3 DATA POINTS

When a Periodic trigger mode is selected, the **Data Log Setup** screen shows the number of set data points. The number of data points is directly linked to the time interval and the set log duration. For example, if a time interval of 10 seconds (00:00:10.0) and log duration of 1 minute (000:01:00) is set, the number of data points shown in the setup menu will be 6. Each time the time interval or log duration value is changed, the number of data points is automatically adjusted. An alternative is that the periodic data log is set by the number of data points wanted and the time interval or sampling frequency. From the previous example, if the number of data points changes from 6 to 5, the log duration will automatically adjust to 50 seconds (000:00:50) based on the unchanged time interval of 10 seconds and the new number of selected data points.

10.3.3.1 How to Set the DATA POINTS

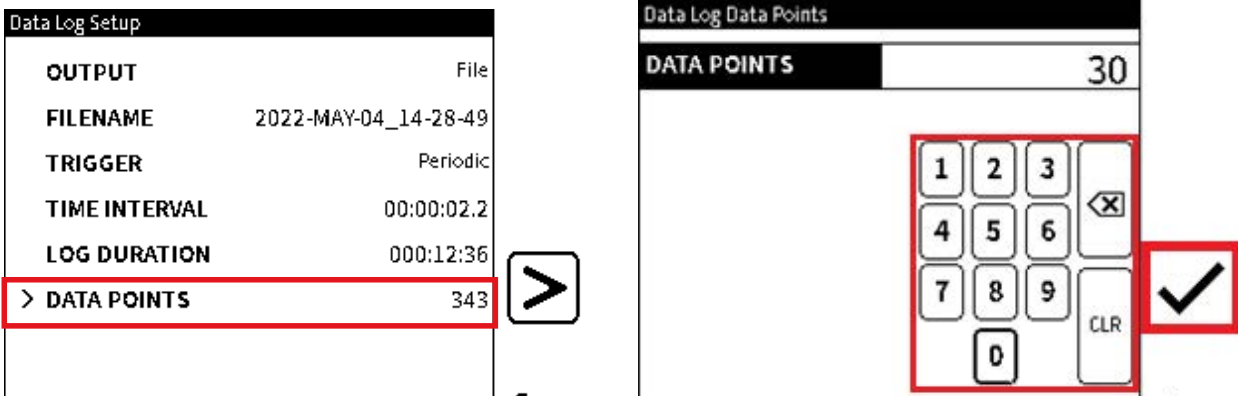

- 1. Select **DATA POINTS** from the **Data Log Setup** screen.
- 2. Use the keypad to set the number of data points and select ✓ to confirm.

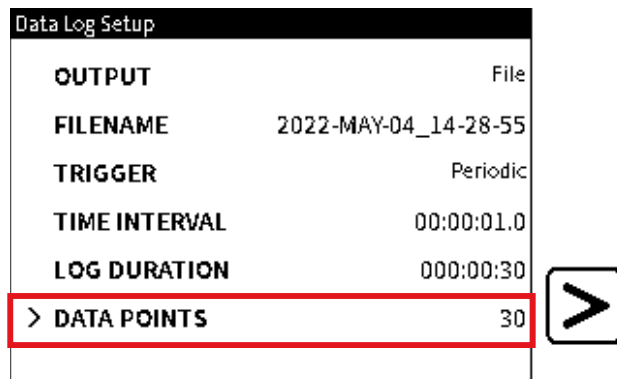

- 3. Make sure that the screen shows the wanted number of data points in the **DATA POINTS** field of the **Data Log Setup** screen.

10.4 Setting up Manual Data Logging

The **KEY PRESS** option (see Section 10.2 on page 155) is a manual data trigger. Use the following steps to continue with a **KEY PRESS** triggered Data Log.

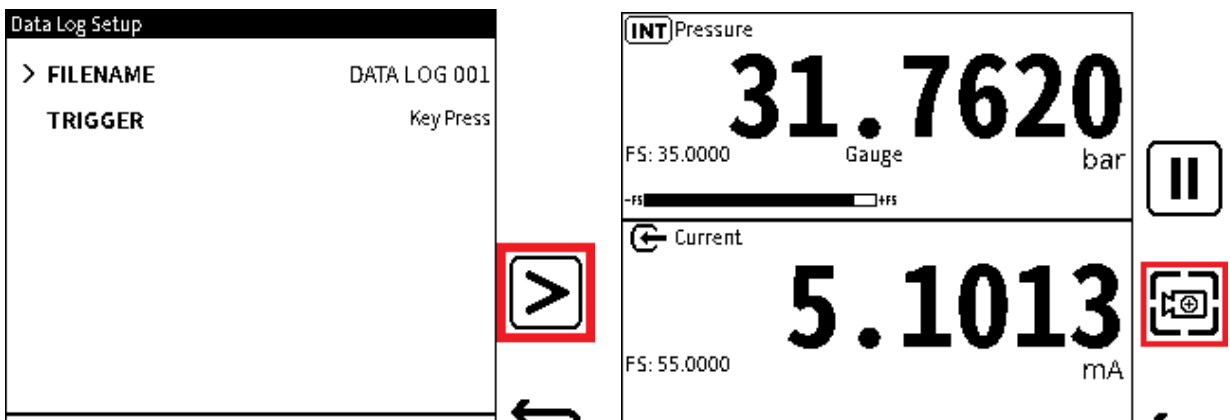

- 1. Select the **Proceed** > icon in the **Data Log Setup** screen.

- The **Calibration** primary screen appears. Select the **KEY PRESS RECORD**  icon to start the data logging.

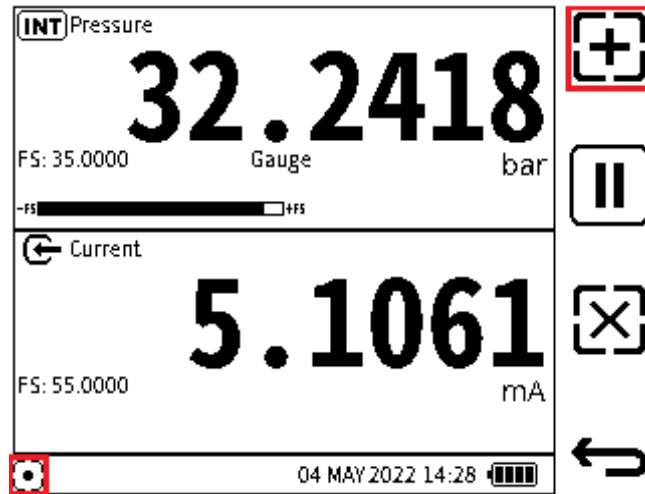

- The **Data Log Status**  icon will appear in the status bar until the logging is complete. The icon animates each time a data point is logged.

Select the **Start Logging Data**  icon to log data when wanted.

To temporarily stop the logging select the **Hold**  icon.

To start again the logging, select the **Hold** icon.

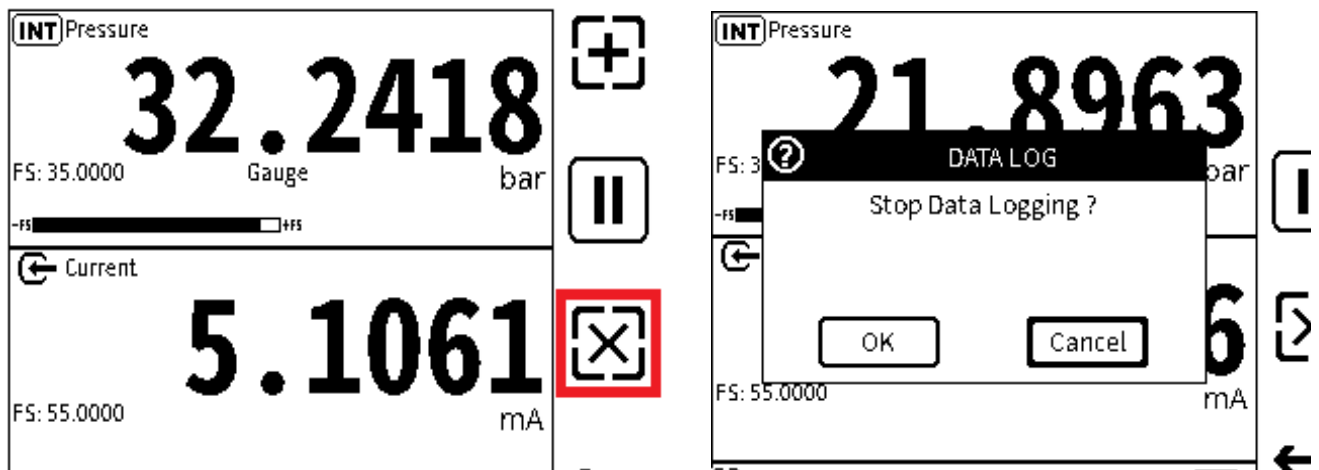

- To stop fully data logging, select the **Stop**  icon.
- The screen shows a popup window. Select the **OK** button to fully stop the Data Logging. The screen will then show a message that the data log file has been saved. Select the **Cancel** button to continue the data log logging.

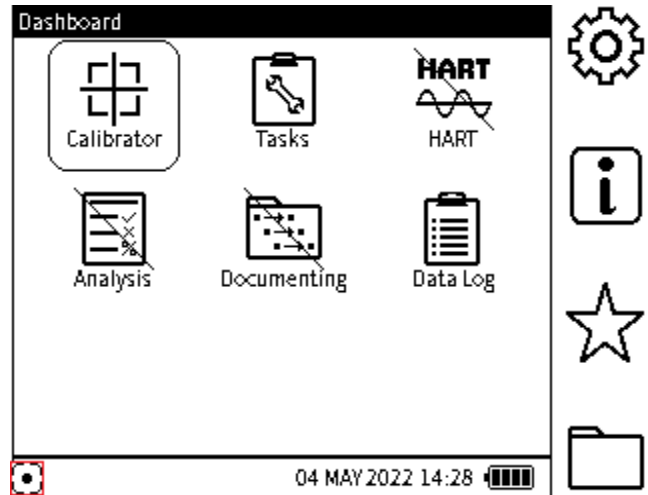



Note: It is not possible to change the channel setup after data logging starts.

If the user selects the Dashboard while data logging, some applications that can interfere with the logging, will not be available for use. This type of application will have a slash across its icon on the Dashboard.

10.5 How to Do Periodic Data Logging

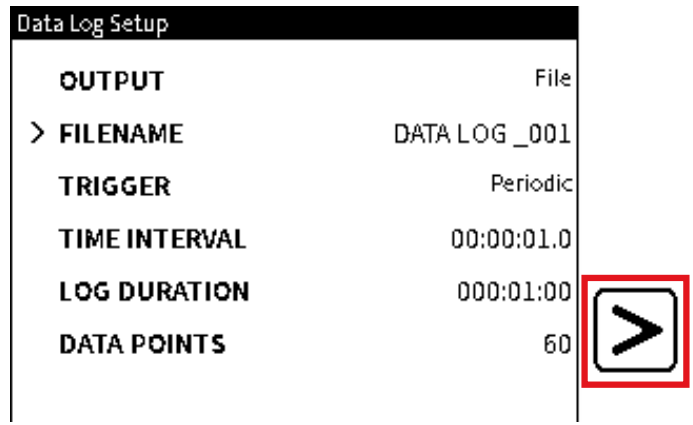
The **PERIODIC** option is a time-based data trigger (see Section 10 on page 153, Section 10.2 on page 155 and Section 10.3 on page 155). Use this procedure to continue with a **PERIODIC** triggered Data Log:



1. After the selection of the **PERIODIC Data Log** mode and the values of the **PERIODIC** options, select the **Proceed**  icon in the **Data Log Setup** screen. The display then shows the **Calibrator** primary screen.

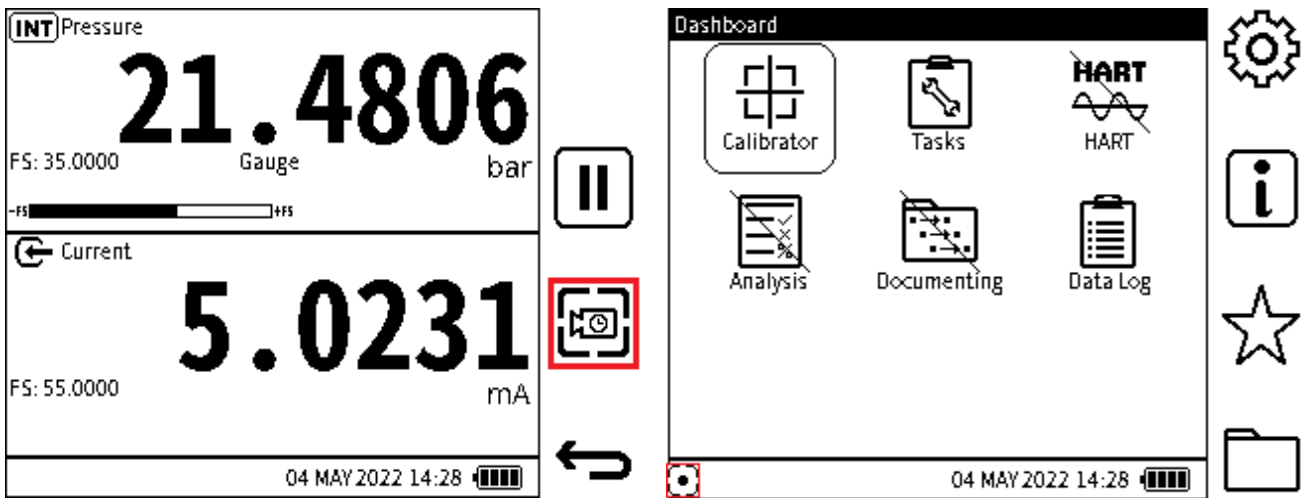

- To start the periodic logging, select the **Periodic Data Log**  Softkey. This is almost the same as the icon for the **Key Push Data Log** icon, but it has a clock in its center rather than an addition sign.

The status bar shows the **Data Log Status**  icon until the logging is complete. The icon animates each time a data point is logged. Periodic logging is automatic, and uses the setups in the **Setup** menu. At the end of data logging the screen shows a message that data logging is done. The file is saved automatically.

It is not possible to change the channel setup after data logging has started.

If the user selects the Dashboard while data logging, some applications that can interfere with the logging, will not be available for use. These applications will have a slash across the icon on the Dashboard.

10.6 Viewing & Deleting Data Log Files

10.6.1 To View Data Log Files on the Instrument

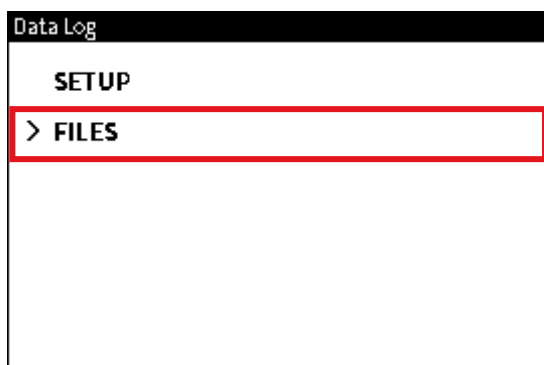

Data Log File 1/3		
FILENAME	CH1	CH2
> 2020-JAN-04_20-59-00	PInt	mA
2020-JAN-04_20-59-01	PInt	mA
2020-JAN-04_20-59-02	PInt	mA
2020-JAN-04_20-59-03	PInt	mA
2020-JAN-04_20-59-04	PInt	mA
2020-JAN-04_20-59-05	PInt	mA



- Select **FILES** in the **Data Log** screen.
- Select the wanted **Data Log** file.

Data Log File Summary	
FILENAME	2020-JAN-04_20-59-00
DATE/TIME	07/01/2000 04:05:06:789
FUNCTION	Plnt - mA
TRIGGER	PERIODIC
INTERVAL	00:00:02.0
DURATION	000:01:00
DATA POINTS	99



File 2022-JAN-04_20-59-00		001-010/010			
CH0 Function=Plnt NegPS=0.00000 PosPS=20.0000 Unit=bar SensorType=Abs Flow=0 MaxMinAvg=0 Filter=0 Tare=0 CH1 Function = mA NegPS =-55.0000 PosPS =55.0000 Unit =mA					
#	Time	Plnt	mA	None	None
1	22:03:00	1.012544	5.60100		
2	22:03:01	2.012754	6.80700		
3	22:03:02	3.012827	7.40120		
4	22:03:03	4.012703	8.01700		
5	22:03:04	5.012753	9.62803		
6	22:03:05	4.003701	8.01010		
7	22:03:06	3.012034	7.43700		
8	22:03:07	2.012003	6.80100		
9	22:03:08	1.012006	5.61200		
10	22:03:09	0.010754	4.00200		

3. Select the **Clipboard** icon on the **Data Log File Summary**.
4. The screen shows the contents of the **Data Log** file.

10.6.2 To View Data Log files on a PC

Data log files are saved in CSV format in the DPI610E internal memory. Use a micro-USB data cable to connect the DPI610E device to the PC. (See Section 10.7 on page 164). On the PC, the Windows File Explorer shows the DPI610E memory as a mass storage device or drive.

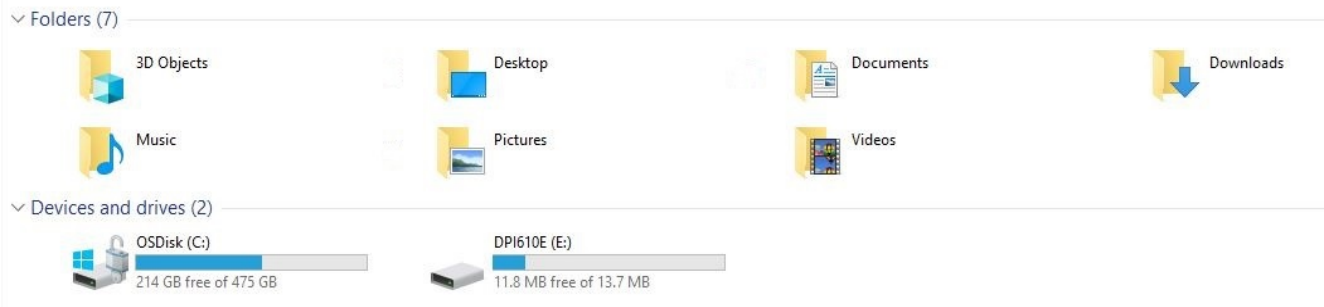

Select the DPI610E drive and select the **DataLog** folder from the root directory.

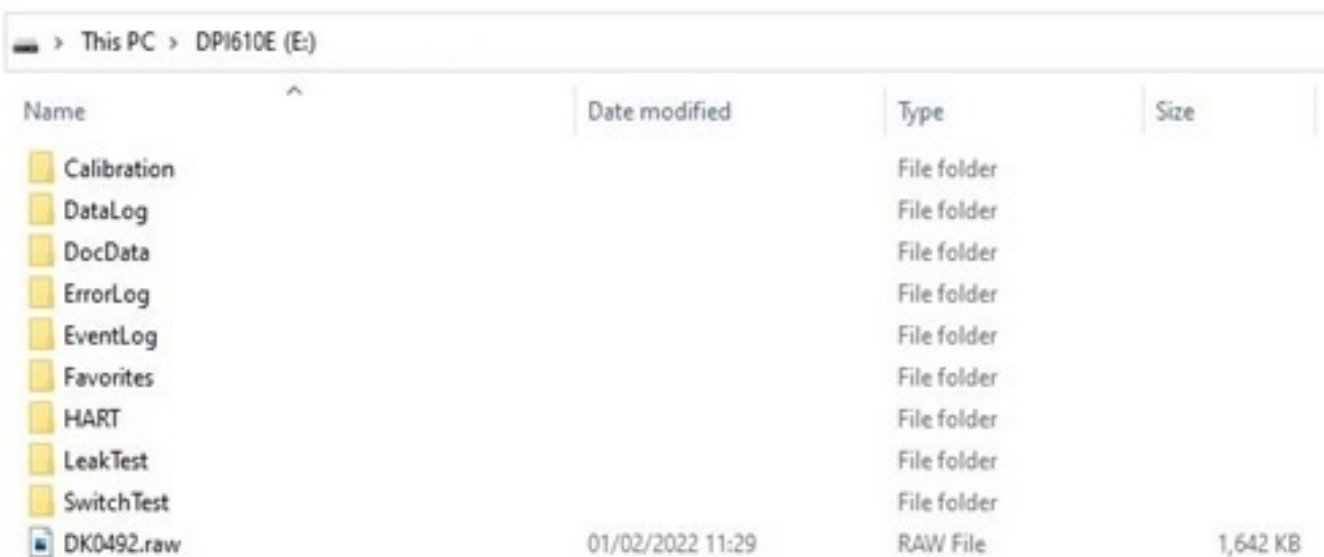

Right-click on the wanted log file and select a supported application to open the file and look at the contents: Microsoft Excel is recommended.

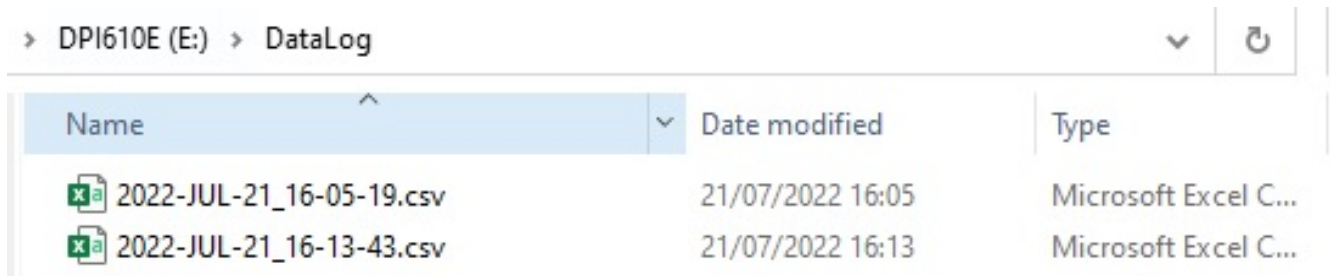

10.6.3 How to Erase Data Log Files

10.6.3.1 To Erase a Single Data Log file

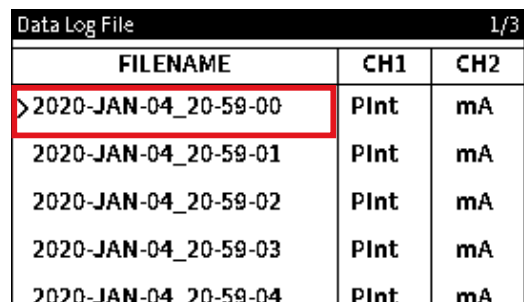
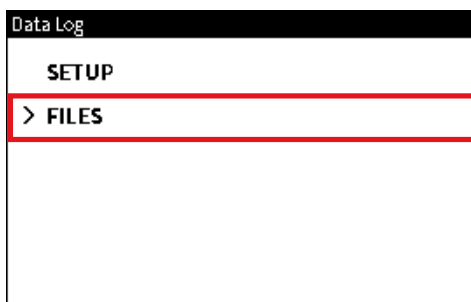

1. Select **FILES** from the **Data Log** screen.
2. Select the **Data Log** file.

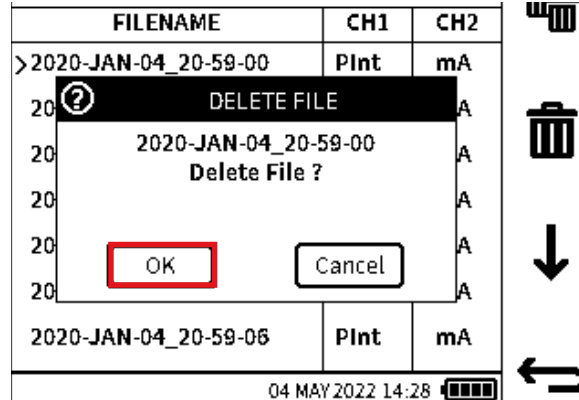
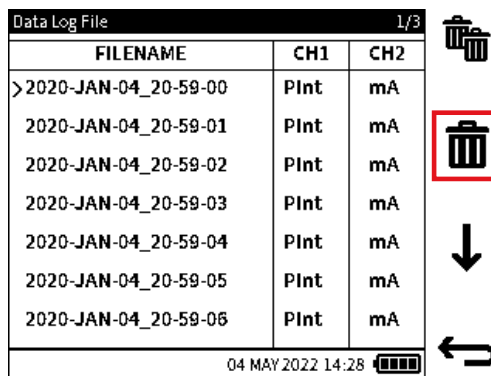

3. Select the 'single' trash icon on the **Data Log File** screen.
4. Select **OK** to erase the file.

10.6.3.2 To Delete all Data Log Files

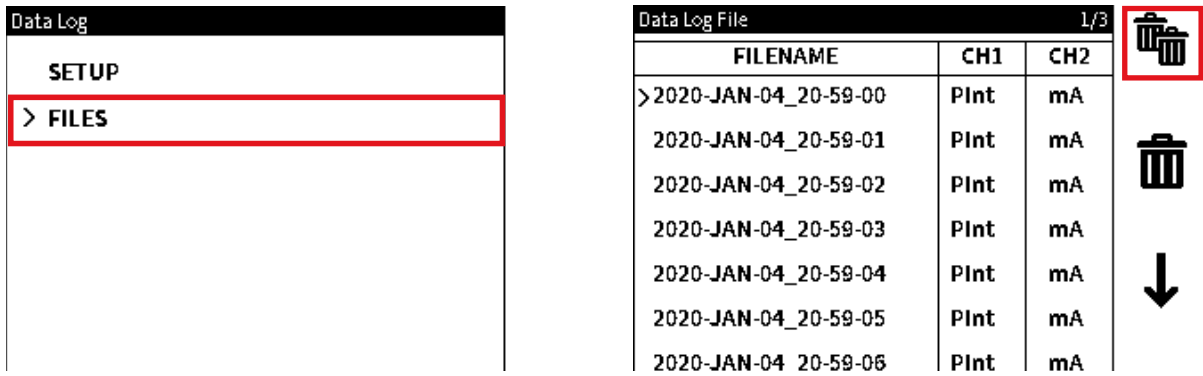

1. Select **FILES** from the **Data Log** screen.
2. Select the 'double' trash icon on the **Data Log** summary screen.

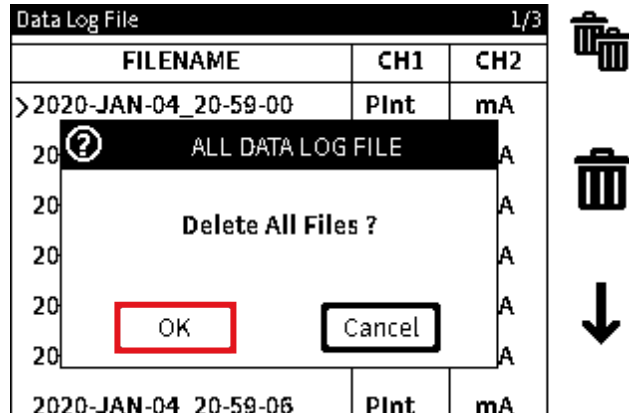



3. Select **OK** to erase all the files.

10.7 How to Copy a Data Log file

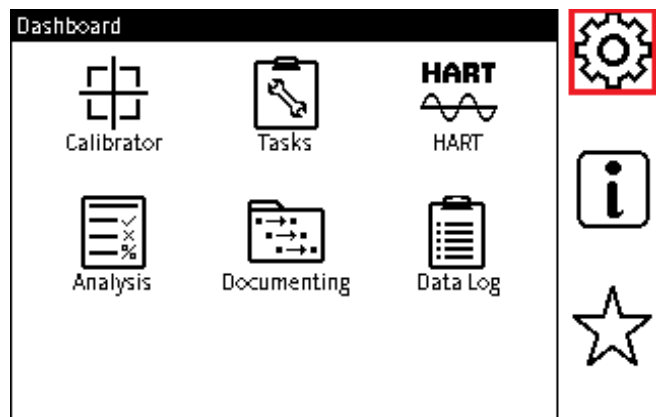
Copies of **Data Log** files can be moved from the DPI610E internal memory to an external device. This device can either be a micro-USB memory stick or an external PC.



1. Select the **Settings** icon  on the Dashboard. Push the **Home** button  if necessary, to show the Dashboard.

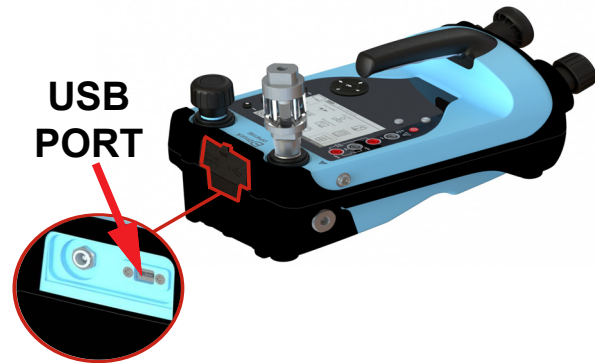
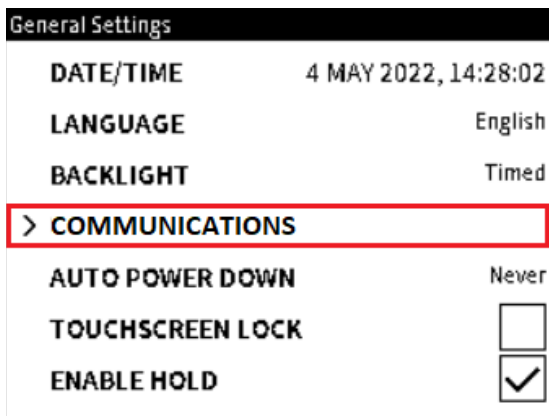

2. The screen shows the **General Settings**. Select the **USB** option.

Push a micro-USB memory stick into the USB port that is behind a rubber flap at the end of the instrument. Use a USB port converter if only a standard USB memory stick is available. If a copy of the Data Log file is to be put into the memory of an external PC, connect a micro-USB data cable to the USB port.

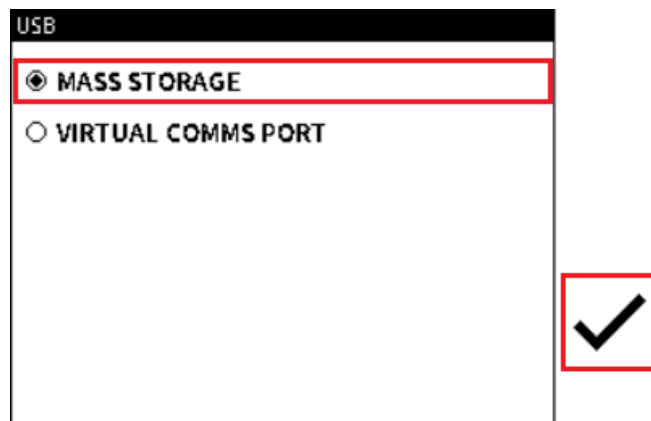

3. Select **MASS STORAGE**, then select to make the selection.

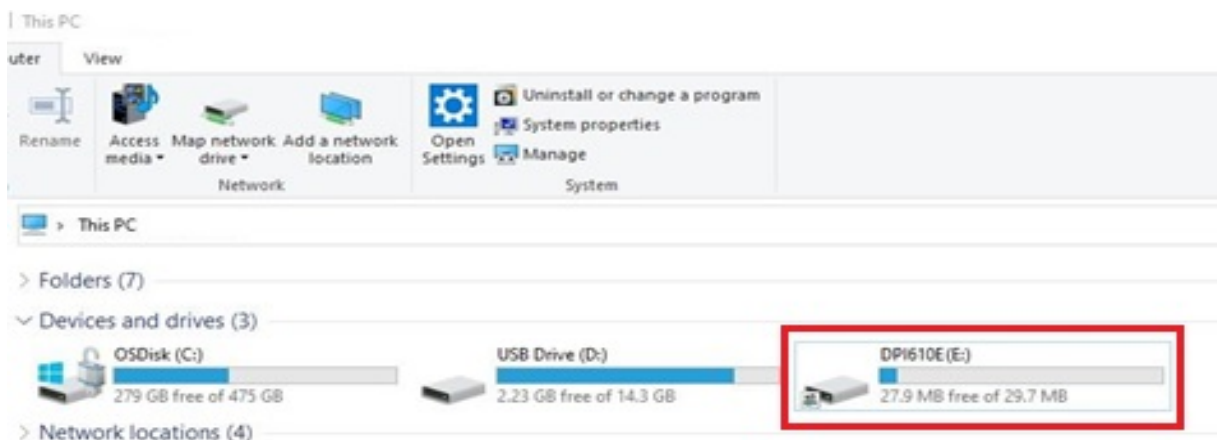

Chapter 10. Data Log

4. Use a micro-USB data cable to connect the DPI610E to the PC. The PC will automatically sense the DPI610E, which will be shown as a Mass Storage drive (default name is DPI610E).

Note: USB access must be available for the PC to use this function.

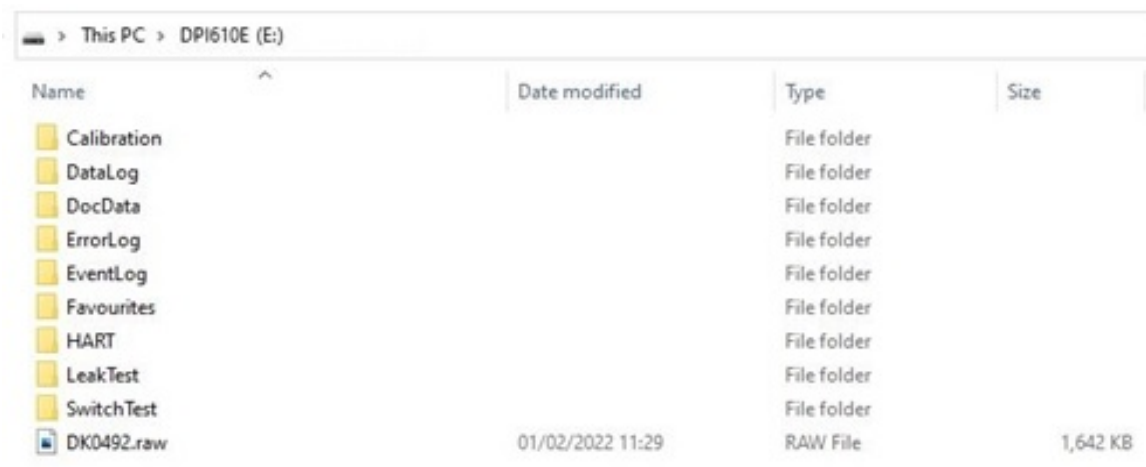

The screenshot shows a Windows File Explorer window with the address bar set to 'This PC > DPI610E (E:)'. The main area displays a list of folders and files in a table format. The folders include Calibration, DataLog, DocData, ErrorLog, EventLog, Favourites, HART, LeakTest, and SwitchTest. The file DK0492.raw is listed at the bottom with a date modified of 01/02/2022 11:29 and a size of 1,642 KB.

Name	Date modified	Type	Size
Calibration		File folder	
DataLog		File folder	
DocData		File folder	
ErrorLog		File folder	
EventLog		File folder	
Favourites		File folder	
HART		File folder	
LeakTest		File folder	
SwitchTest		File folder	
DK0492.raw	01/02/2022 11:29	RAW File	1,642 KB

5. When the copy operation is complete, remove the cable from the DPI610E.

11. Analysis

11.1 Overview

The **Analysis** application calibrates the transfer characteristic of a device under test (DUT). This is done by the use of readings from the two channels. One channel operates as the Input channel and the other channel as the Output channel.

The Input channel shows the measurement of the input signal to the device under test (DUT). For example, for the calibration of a pressure transmitter, the Input channel can be the DPI610E Internal Pressure, which is a measurement of the supplied pressure to the DUT.

The Output channel measures the output signal from the DUT. For the calibration of a 4 to 20 mA process transmitter, the output channel will be the Current Measure.

By default, the Analysis application uses the functions and measurement units set up in CH1 as the Input and the function set in CH2 as the output. Thus, the wanted functions for analysis must be selected in the Calibrator screen before the Analysis application is started. (Refer to “Calibrator Tasks” on page 47 for more details).

There is an option to change between Input and Output selection for both functions.

For the Analysis application to operate, valid functions must operate on both channels: all function options can be used, but not the option “None”.

At each test point value, the Analysis function calculates the difference of each Output channel to the ideal transfer characteristic and compares this value to a user-specified tolerance limit. This deviation is calculated and can be shown in different user-defined formats. Also, the tolerance test result can be shown as a **Pass** or **Fail**.

11.2 Analysis Application

Select the **Analysis** icon on the Dashboard to start the Analysis application.

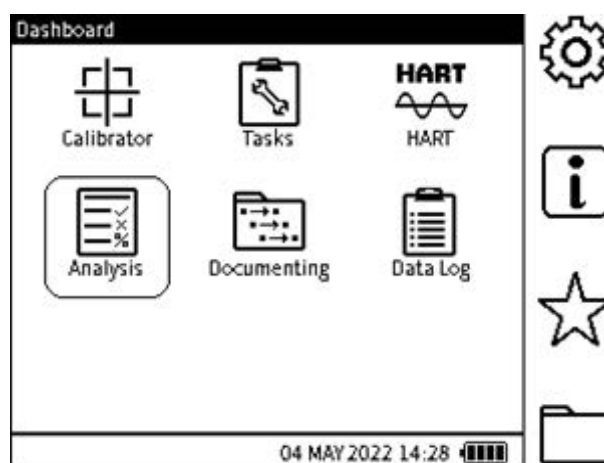

Figure 11-1: Instrument Dashboard

11.3 Setup

The **Analysis Setup** screen shows the selected **CH1** and **CH2** calibrator functions and measurement units. The necessary functions wanted in the Analysis application, have to be selected in the Calibrator application before the analysis is done. For example, to do an analysis on a pressure transmitter with a 4 to 20 mA output, **CH1** can be set to **INT Pressure** and **CH2** to **Current Measure** (with 10/24 V power if wanted). Select the wanted types of measurement units.

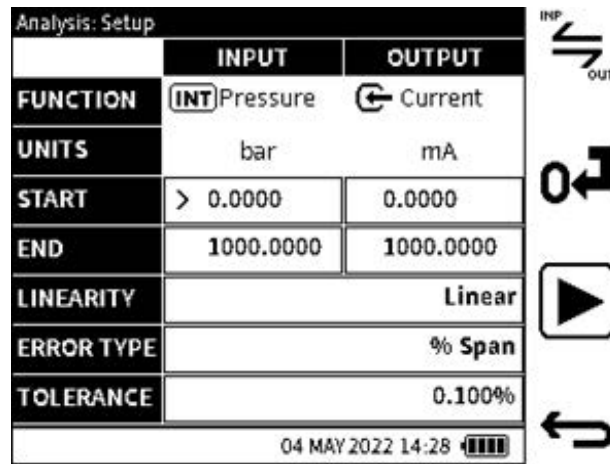

Figure 11-2: Analysis Function screen

The **INPUT** and **OUTPUT** functions can be interchanged by the use of the toggle  Softkey.

11.3.1 START/END Values

The specified measurement range for the input and output channels is set by a **START** (Low) and **END** (High) value for each channel. The screen shows the negative and positive full-scale values of the related function which are usually the default values. When Current Measure is selected, the default **START** and **END** values, are 4 and 20 mA. When **START** and **END** values are entered, a value that is not in the full-scale limits of the selected function will be rejected.

11.3.2 LINEARITY

The transfer characteristic from **INPUT** signal to the **OUTPUT** signal can be either:

- **Linear** - when the transfer characteristic is a directly proportional relationship.
- **Square Root** - when the transfer characteristic has a square-root relationship. This is commonly found in flow sensors.

The Linearity option is automatically selected.

11.3.3 ERROR TYPE

The error or deviation from the transfer characteristic can be calculated and shown in one of these formats:

- **% Span** - a percentage of the Output signal span.
- **% Full Scale** - a percentage of the Output signal full-scale.
- **% Reading** - a percentage of the Output signal reading.
- **Fixed** - absolute measurement units of the Output signal.

The default option is ‘% Span’.

11.3.4 TOLERANCE

Use this option to set the tolerance or test limit values for the calculated result error or deviation from the transfer characteristic. The tolerance value is shown either as a percentage (%) or as an absolute or fixed measurement unit, for example, mA. This is reliant on the Error type selected. The default tolerance value is 0.1%.



11.4 Analysis Function

Set the **Input** and **Output** channel and error analysis parameters. Refer to “Analysis Application” on page 167 for more information.

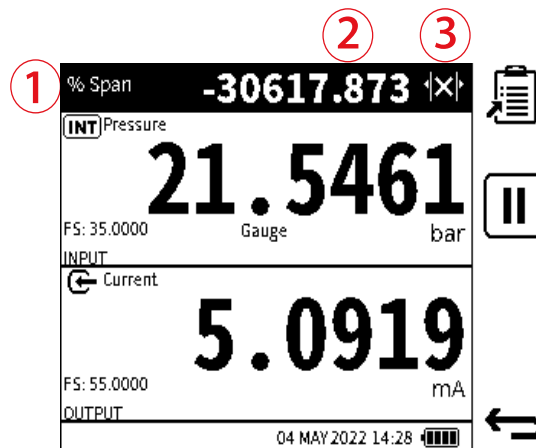
Select the **Play**  button to start.



The **Analysis** primary screen shows the following:

1. The deviation tolerance type.
2. The error/deviation value of the output channel from the ideal transfer characteristic.
3. A real-time indication of the tolerance result status icon, which is one of the following:
 - PASS  - the real-time measured output value is in the specified tolerance limits.
 - FAIL  - the real-time measured output value is not in the specified tolerance limits.



The screen is in two areas. Each area shows information for a channel and is either the **Input** or **Output** channel.

To test the full range of the Device Under Test (DUT):

- Increase the input signal value as steps through its range. In the example screen shot, increase the internal pressure made by the DPI610E pump, from the lower range of the DUT to the full-scale pressure value.
- At each setpoint step, examine the Analysis status at the top of the screen for the deviation.
- When the test is complete, use the **Back** button to go from the Analysis screen.

11.4.1 DATA LOGGING Within Analysis

The examination of a DUT in the Analysis application can be recorded by the use of the Datalog application. To use this function, select the **Data Log**  icon. For more information on **Data Log**, see Chapter 10 on page 153. When the **Data Log** in the Analysis application is used, only the **Key Push** trigger mode is available.

- Enter the wanted **Data Log** file name.
- Select the **Play**  Softkey to continue.
- At each **Setpoint** step (or when wanted), push the “Add Data point”  Softkey to capture the live analysis data shown by the screen.
- When the test is complete, tap the **Back**  icon to go from the Datalog and Analysis application.

Use the **Data Log** application to get access to Datalog files (Refer to “Data Log” on page 153).

12. Documenting

12.1 Overview

Use the Documenting application to do documented calibration of Device Under Test (DUT) equipment or of assets that use specified test procedures.

The Documenting application can make and keep test procedures for future use.

When test procedures are used to calibrate DUTs, the test data and results of the calibration are put into storage in the DPI610E memory. This data can also be copied to a PC for further analysis or post-calibration tasks.

To select an icon, push in the related Softkey on the right side of the display or tap on the screen icon.

A calibration certificate template wizard is supplied by Druck. This puts the data into an applicable form for use in printing or filing. The related Excel Macro file is available on: Druck.com/DPI610E as “Druck DPI610E Calibration Template”.

12.1.1 How to Start the Documenting Application

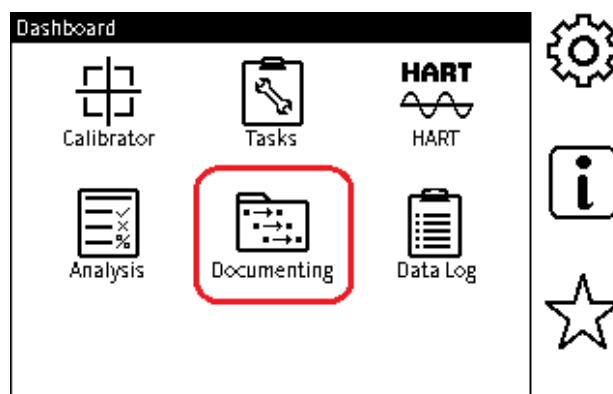

Select the **Documenting** Softkey from the Dashboard. This shows the **Procedures** screen.

12.2 Internal Procedures

12.2.1 How to Select the INTERNAL PROCEDURES Mode

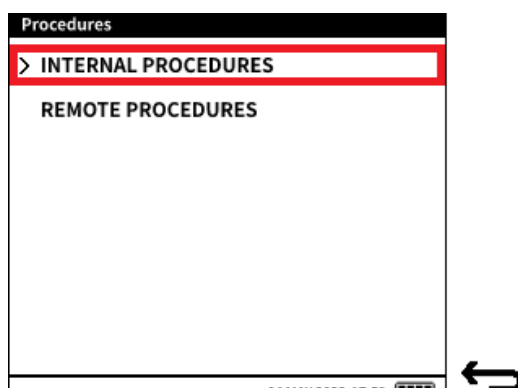

To look at, make or operate internal procedures, select the **INTERNAL PROCEDURES** Softkey from the **Procedures** screen. This will show a list of available internal procedure files.

12.2.2 How to Make an Internal Procedure



- 1. The display shows this screen after **INTERNAL PROCEDURES** has been selected from the **Procedures** screen (see Section 12.2.1 on page 171).

The **Internal Procedure Files** screen shows a list of available internal procedure files. The number of Assets on which each procedure has been done and calibration results saved, will also be shown together with the Procedure file name.

See Section 12.2.3 on page 179 on how to do a test procedure.

If no procedures have been made or saved, the **Internal Procedures** screen will be empty.

Select the **New Procedure**  Softkey to start the Procedure Creation wizard.

Note: Functions on **CH1** and **CH2** set in Calibrator, are used as the input and output functions when an internal procedure is made.

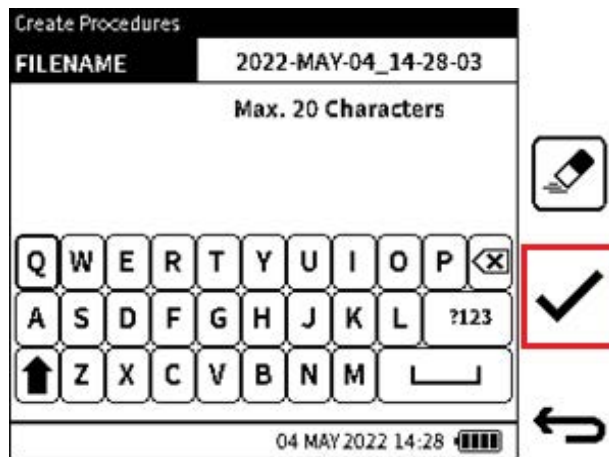

- 2. Enter a file name for the test procedure or use the default file name. This default file name uses the system date and time stamp.

Note: A maximum of 20 characters is available for the file name.

Select the **Tick**  Softkey to set and show the **Create Procedure** screen.



3. Select the type of calibration wanted. **Proportional** is the default option.

Push the **Next**  Softkey to continue or the **Previous**  Softkey to go back one step.

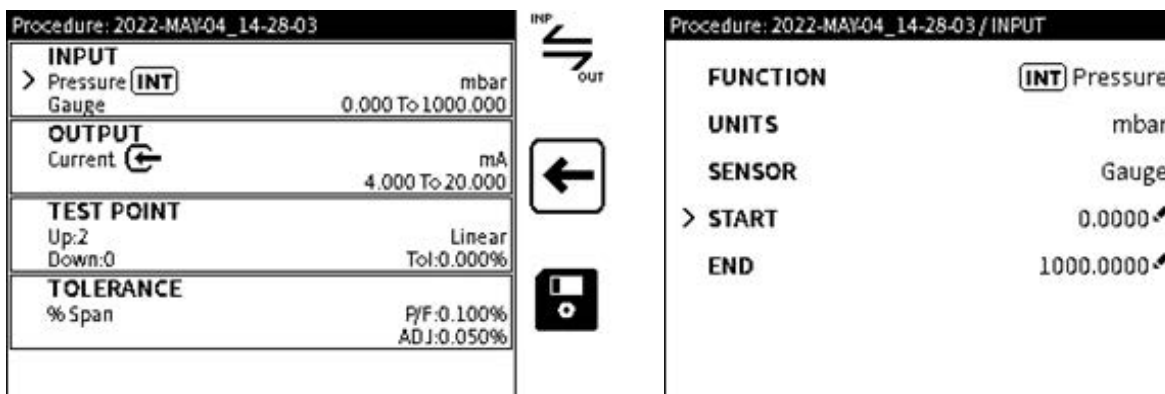

4. This is the test procedure setup screen that has these data rows:

- Input
- Output
- Test Points
- Tolerance.

These areas are automatically filled in with data taken from the current Calibrator setup, parameters set in the Analysis application setup and other default settings. Data about each area is given in the following steps.

- **INPUT:** The input relates to the test input signal to the Device Under Test (DUT). The input function type, the sensor type (where applicable), the range, and the measurement units are all in this area.

By default, the Function (and thus Sensor type) set up in **CH1** is set as the input with the selected **Units**. These are read-only and not changeable in the procedure creation wizard. If changes are necessary, these must be done in Calibrator before the use of the Documenting application.

The input range is automatically filled in with the full sensor range related to the Function. Only the range can be changed and must be in the full sensor range.

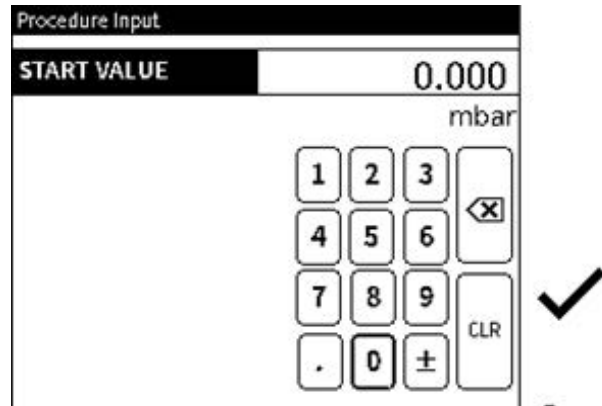

Set the **START** and **END** values of the input range if different to the values shown.

Note: The **Toggle**  Softkey can be used to interchange the Input and Output functions: to use the original Input function as the Output function and the original Output function as the Input function.

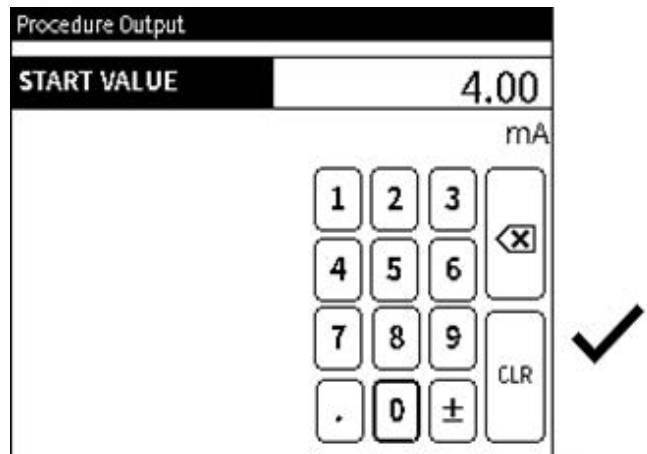
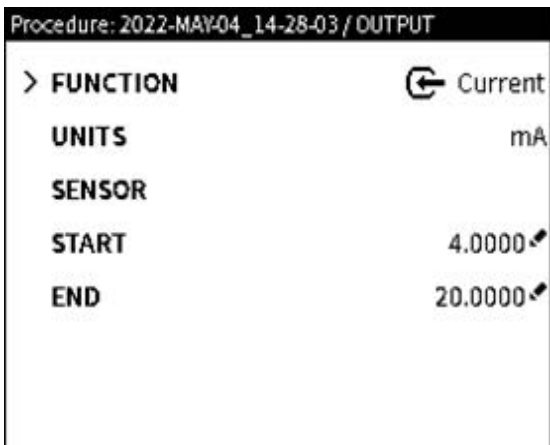

- **OUTPUT:** The Output refers to the output signal from the Device Under Test (DUT). By default, the **FUNCTION** (and thus **SENSOR** type) set up in **CH2**, is set as the output with the selected **UNITS**. These are read-only and not changeable in the procedure creation wizard. If changes are necessary, these must be done in Calibrator before the use of the Documenting application.

The output range is automatically filled in with the full sensor range related to the Function. Only the range can be changed and must be in the full sensor range.

Set the **START** and **END** values of the input range if different to the values shown.

Note: The **Toggle**  Softkey can be used to interchange the Input and Output functions: to use the original Input function as the Output function and the original Output function as the Input function.

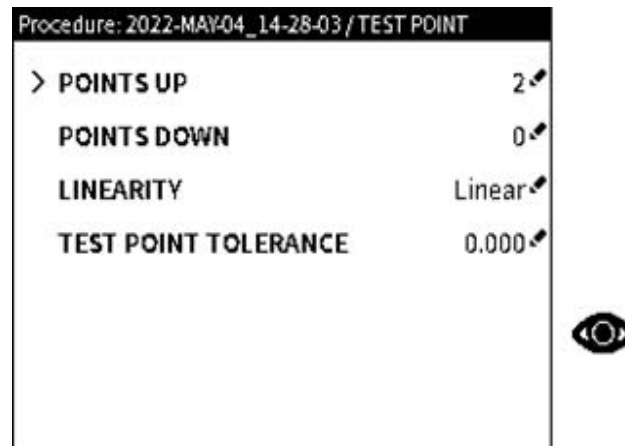

- **TEST POINT TOLERANCE:** This refers to input points at which the device under test (DUT) is tested and its calibration data recorded.
- **POINTS UP & POINTS DOWN:** The number of calibration points must be specified in the specified Input range. This can be specified as **POINTS UP** - direction from **START** range value to **END** range value. **POINTS DOWN** - the direction from **END** range value to **START** range value. The default setting is 2 POINTS UP and 0 POINTS DOWN. This means there will be two test points - the first test point will be the Input Start value and the second will be the Input End value.

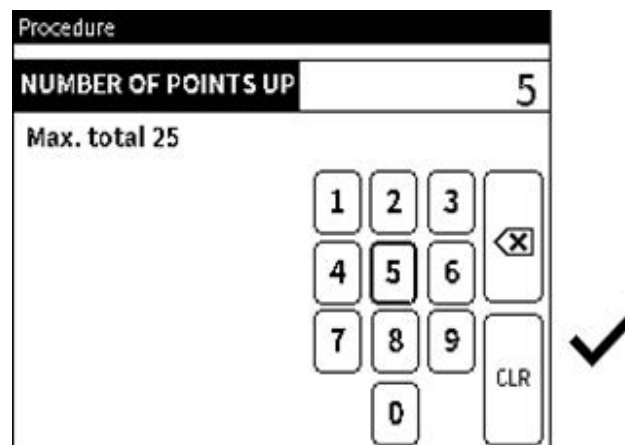

Set the wanted number of points UP and DOWN if different from that shown: UP or DOWN values must be between 0 and 25.

Note: There must be a minimum of 2 points UP and a maximum of 25 test points in total (all UP and DOWN points).

For each Points UP and DOWN setting, the test point values are calculated and can be seen by the selection of the **View**  Softkey.

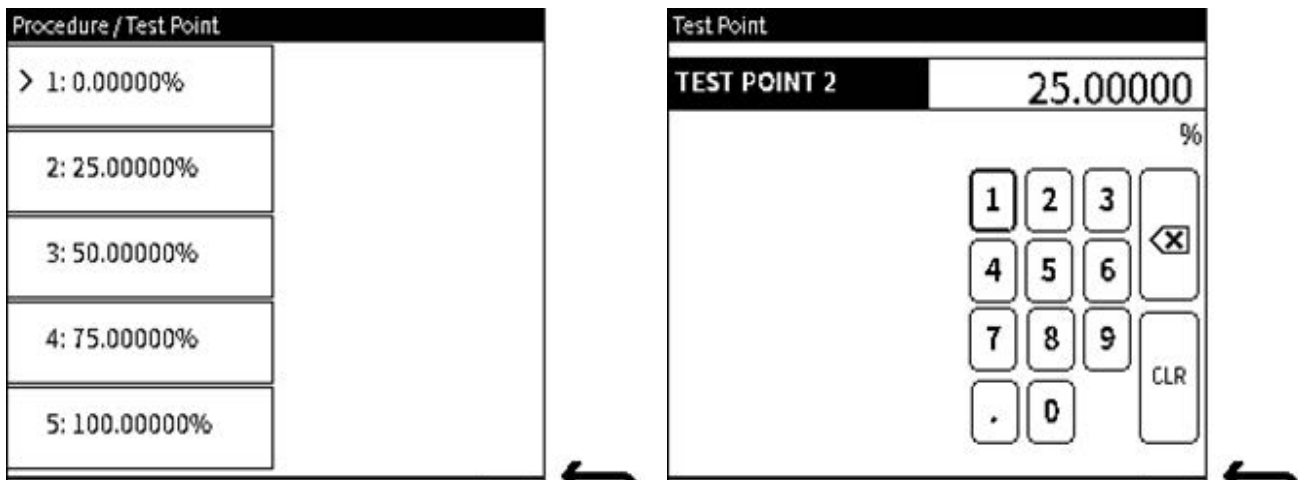

In the **Test Point** screen, it is possible to manually adjust each test point if necessary. Select the related test point box and change its value as shown.

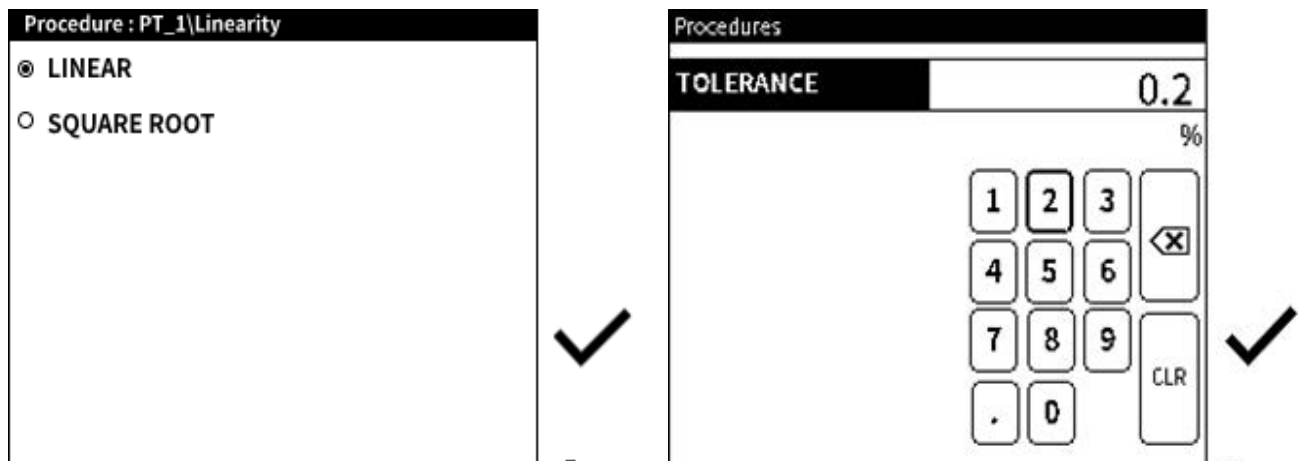

Linearity – the relationship between the input and output can also be specified: either Linear or Square Root transfer function. The default is Linear.

The use of a square root function is necessary for pressure transmitters that measure fluid flow. This fluid flow causes pressure readings that do not follow a linear relationship.

TOLERANCE – this is the maximum deviation or permitted error margin for each input test point in the calibration. It is specified as a percentage of the Input range.

The default test point tolerance value is 5% and can be changed if necessary.

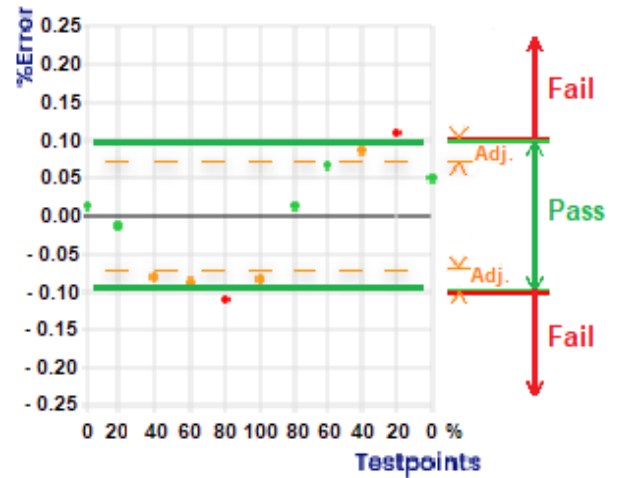
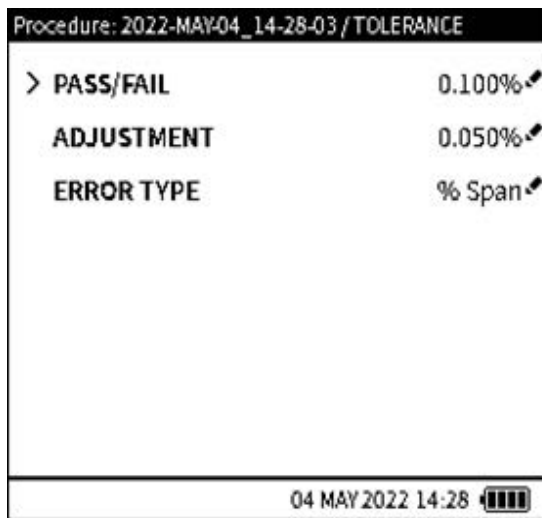

5. **TOLERANCE:** This relates to the deviation on the output signal or result, as a result of each applied input signal setpoint.

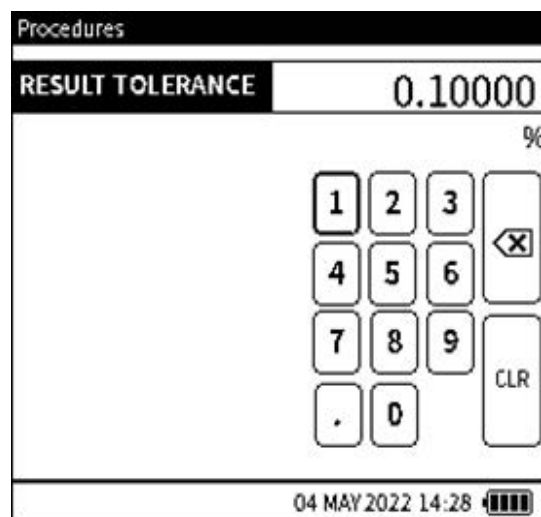

PASS/FAIL (or Result Tolerance) (P/F): This sets the maximum deviation. This sets the limit for when the result (output) at each test point is in specification (**PASS**) or out of specification (**FAIL**). It is measured as a percentage of the output. It can also be in fixed measurement units dependent on the tolerance type.

The default value is 0.1% (based on '% FS').

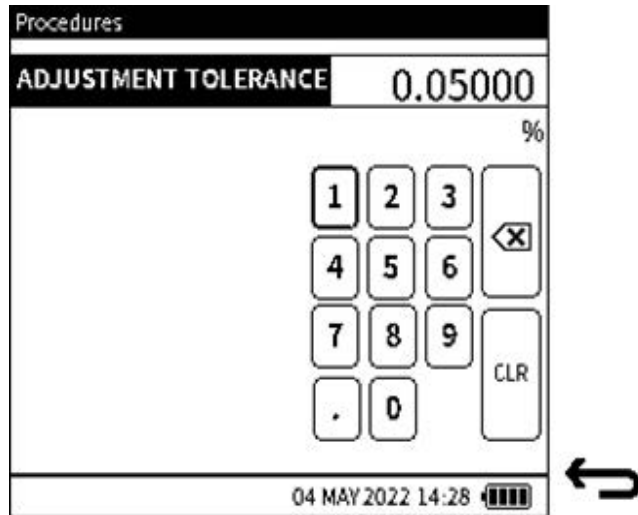

This screen is for the **ADJUSTMENT** value in the **Procedure: PT_1/Tolerance** screen on the previous page. **ADJUSTMENT (Tolerance)**: This sets the maximum deviation in the **PASS/FAIL** tolerance which shows that the Device Under Test (DUT) is near to out-of-specification limits.

Thus, the **ADJUSTMENT** tolerance value must be less than the **PASS/FAIL** tolerance value to be sensed. If an **ADJUSTMENT** tolerance is not necessary, the adjustment tolerance value can be equal to the **PASS/FAIL** tolerance.

The default value is 0.07% (based on% FS).

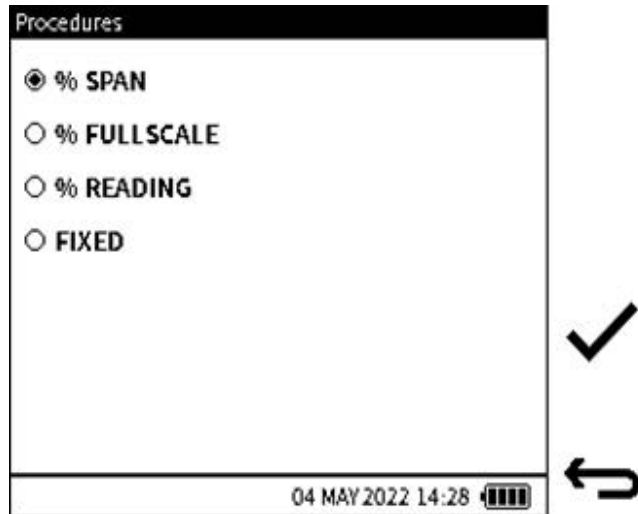

Use this screen to set how the maximum deviation is calculated. The four options for this calculation are given by the graph shown earlier.

ERROR TYPE (Tolerance): this specifies how the maximum deviation is calculated and measured. Options include:

- %Fullscale (Percent of Full-scale)
- %Span (Percent of Span)
- % Reading (Percent of Reading)
- %Fixed (Measurement units).

See Section 11.3.3 on page 168 for more details.

The default is '% Fullscale' (%FS).

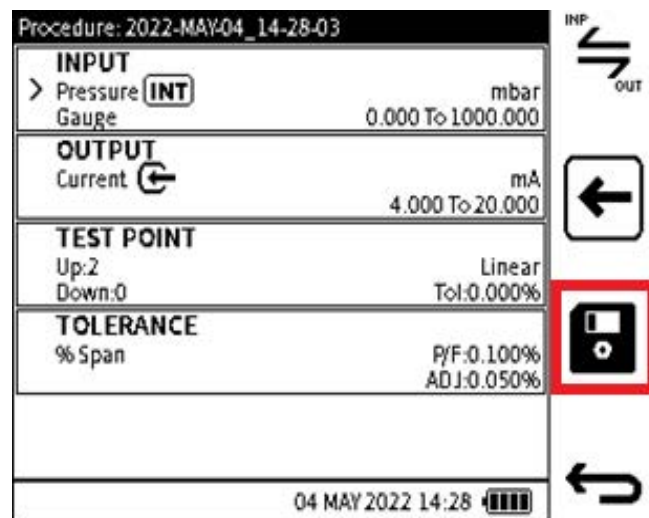

- When the details of the test are completed, push the **Save**  Softkey to save the procedure.

The test procedure after being saved, becomes immediately available for use.

12.2.3 How to Start a Test Procedure

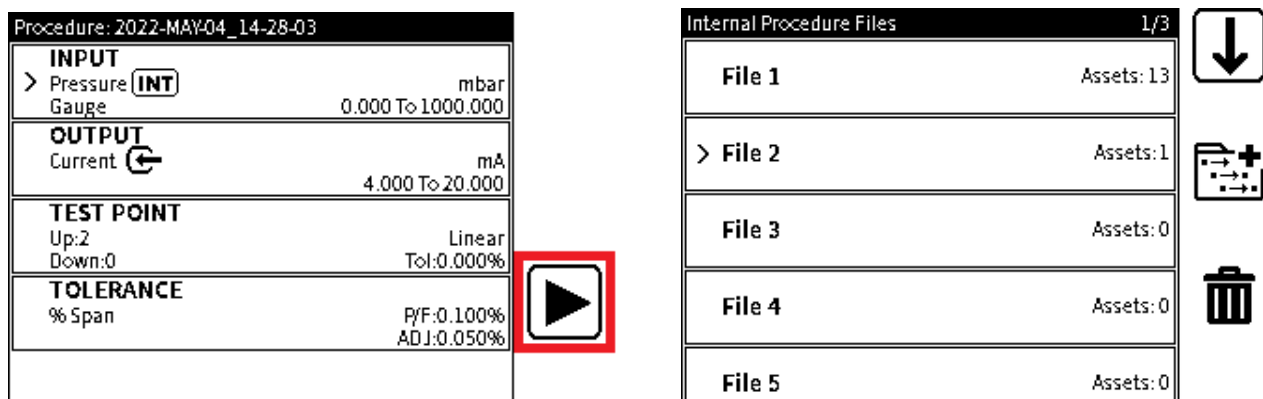

- After the test procedure has been saved successfully, it is available to be used immediately by the selection of the **Play**  Softkey.
- The test procedure can also be selected from the **Internal Procedure Files** screen. To select a test procedure, for example, **File 2**, tap in the row or use the Navigation Pad.

12.2.4 How to Delete a Test Procedure

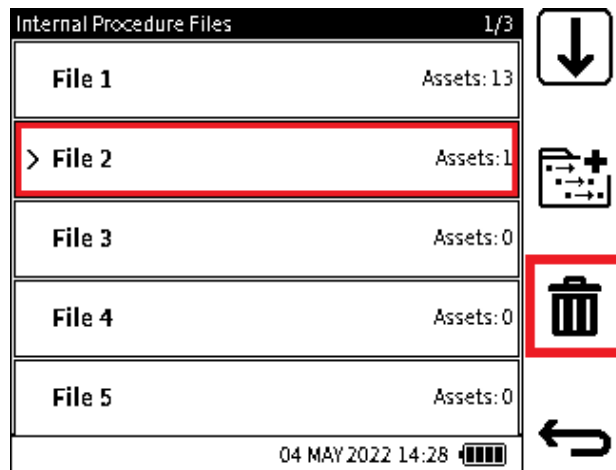

Tap or use the Navigation Pad buttons to select the row that has the test procedure file name: in this example, **File 2**.

Tap or use the Softkey to select the **Delete**  icon, to erase the file name from the list. When a Test Procedure is erased, any asset data saved as part of the procedure file will also be erased.

12.2.5 Test Procedure Parameters

When a test procedure has been made and saved in DPI610E memory, select the **Play** Softkey to use it. Data about the DUT, Environment and User, is necessary each time the test procedure is used.

12.2.5.1 DUT data

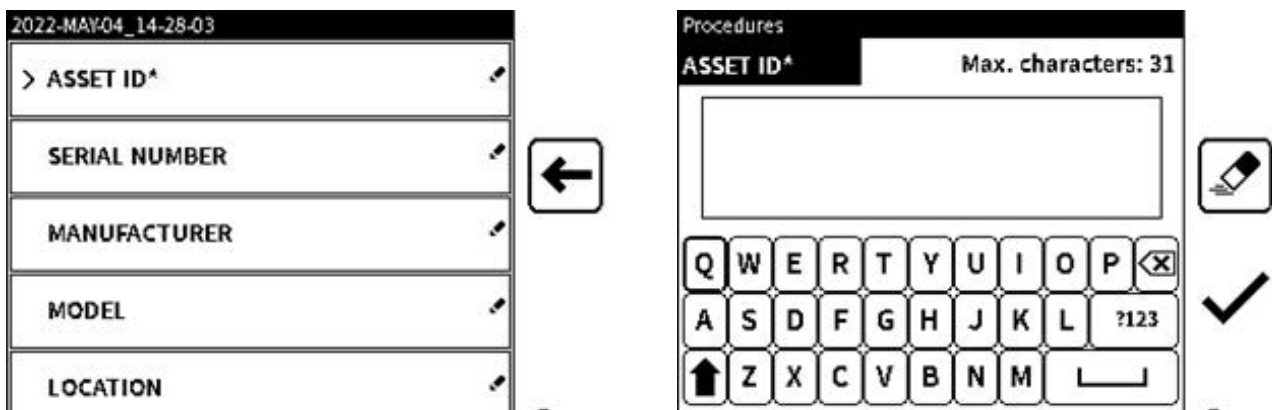

1. Enter the following data about the Device Under Test:
 - **ASSET ID** (Mandatory) – a unique tag or device reference that is given to the asset or DUT. This ID will be used as the default result file name when the calibration is completed. Maximum number of characters: 31.
 - **SERIAL NUMBER** (Optional) – the serial number of the asset or DUT. Leave blank if not known. Maximum number of characters: 50.
 - **MANUFACTURER** (Optional) – the manufacturer of the asset or DUT. Maximum number of characters: 30.

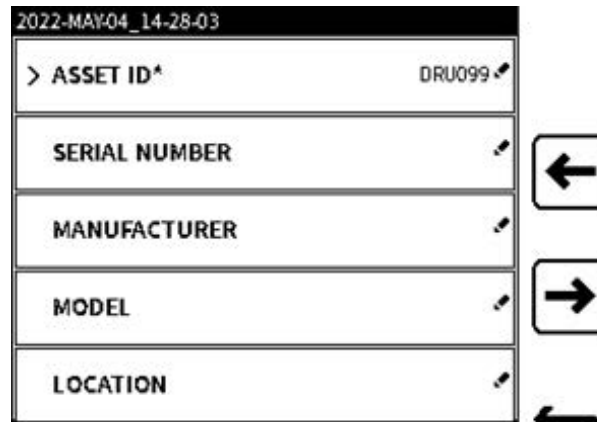

- **MODEL** (Optional) – the model’s name or number of the asset or DUT. Maximum number of characters: 30.
- **LOCATION** (Optional) – the physical location of the asset or DUT. Maximum number of characters: 50.

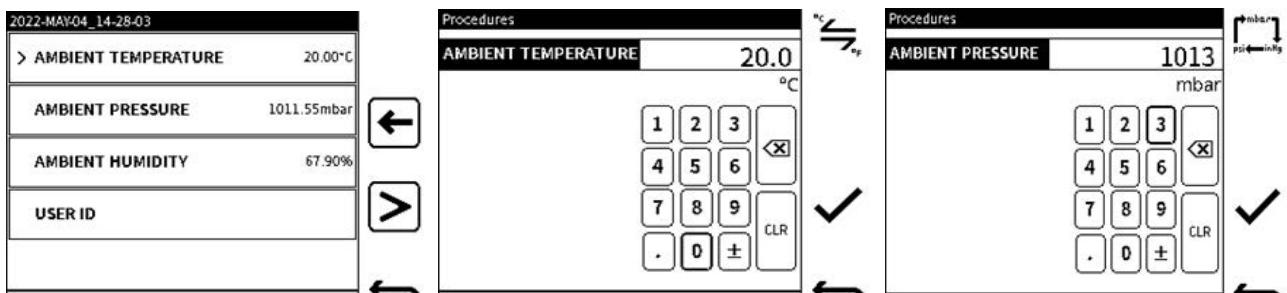

2. When the necessary fields have data in them select the **Next**  screen icon to go to the next step.

12.2.5.2 Environment and User ID Data



1. If necessary, enter the following ambient environment and user details.
 - **AMBIENT TEMPERATURE** – Enter the ambient temperature value where the test is be done. Temperature units available are °C or °F. Use the **Toggle**  Softkey to change between these units. The unit conversion will be done automatically: 20°C is the default ambient temperature. A value entered must be between -100 to +100 °C (-148 to 212 °F).
 - **AMBIENT PRESSURE** – Enter the ambient pressure value (or pressure of the day) where the test is to be done. Pressure units available are mbar, psi or in Hg. Use the **Toggle**  Softkey to change between these units. The unit conversion is done automatically. The default ambient pressure value is sensed from the internal barometer sensor. For DPI610E pneumatic variants, the default ambient pressure value is taken from the internal barometer sensor. On hydraulic variants, the default ambient pressure value is 1013 mbar. Values entered must be between 800 to 1200 mbar (11 to 18 psi or 23 to 36 in. Hg).
 - **AMBIENT HUMIDITY** – Enter the ambient humidity value where the test is done. The default value is 70%. Values entered must be between 0 and 100%bar.

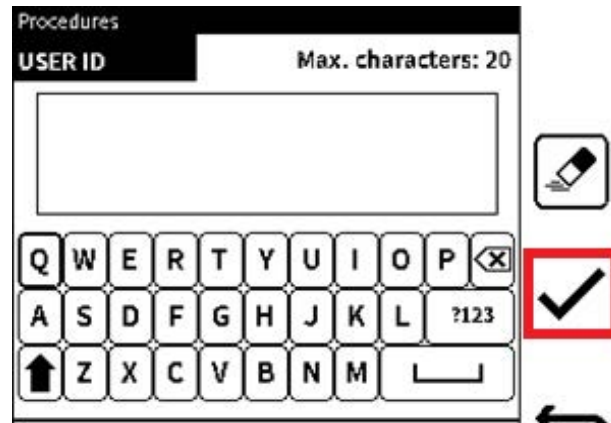

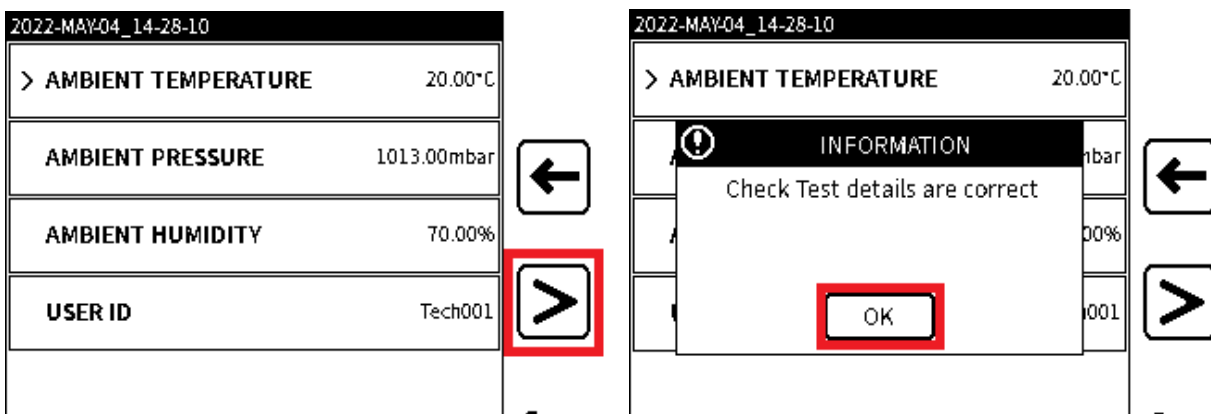

- **USER ID** – enter the **User ID** of the person that does the test procedure. Maximum number of characters: 20.

Select the **Tick** ✓ Softkey to save the User ID entry or select the **Back** ↶ Softkey to go back a screen, without a save operation.

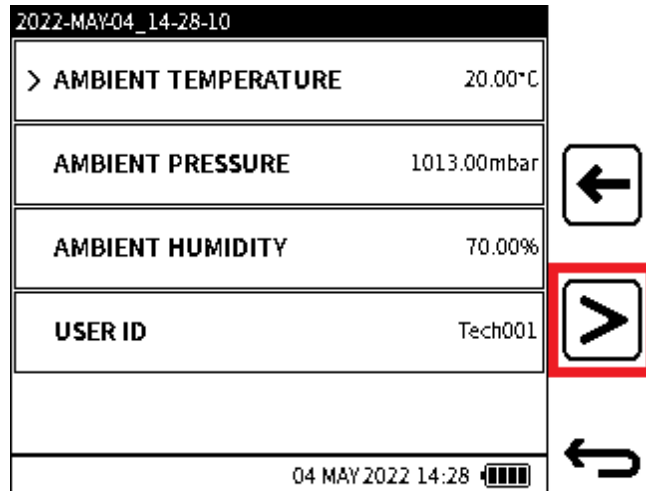

2. After the **Environment** and **User ID** data have been entered, select the **Proceed** ➤ Softkey to continue. The screen will show a popup message to make the user make sure that all the data are correct. Select the **OK** button to remove the message. This gives a checkpoint where the user can go back and check all the data of the test procedure are correct.



When ready to start the test, push the **Proceed**  Softkey to continue.

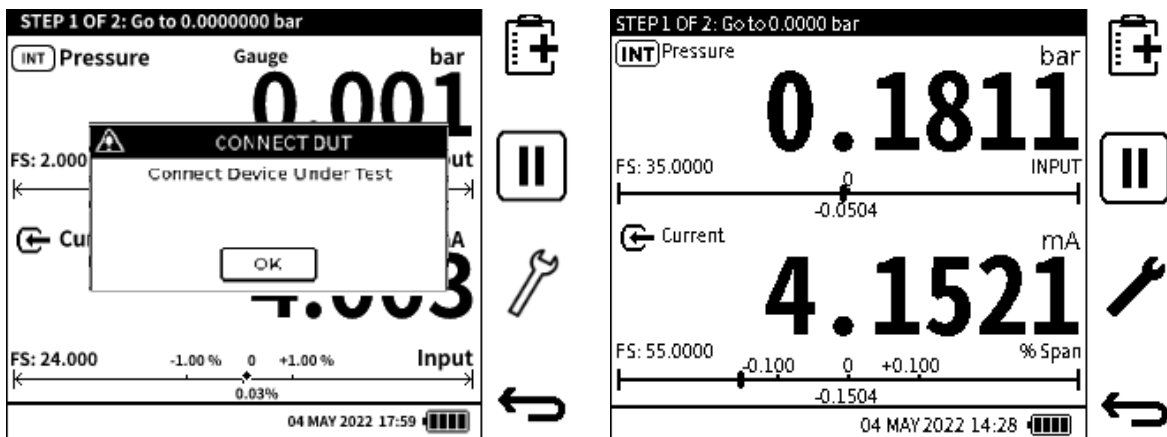

- When the values of the test are set, connect the Device Under Test (DUT), if not done already. The screen will show a popup message that tells the user to make this connection. Select **OK** only when the DUT has been connected successfully.

The DPI610E does a verification check to make sure the connected DUT is compatible with test specifications. If unwanted differences are found, the screen will show a popup message that gives a warning. For example, when a pressure sensor (DUT) is connected, that is a different sensor type to that which the test specifies. Another example is if the DUT connected has an incompatible pressure range to that which is specified for the test.

12.3 The Documenting Main Screen

This section gives information about the different parts of the **Documenting Main** screen.

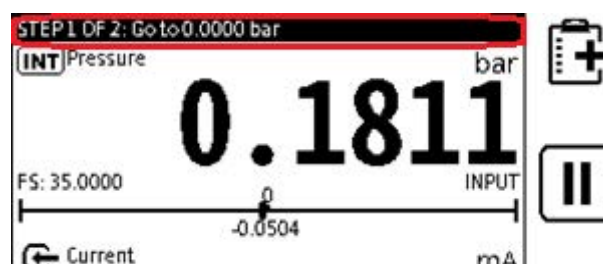

Chapter 12. Documenting

The title bar of the screen has information about:

- Number of steps of the test and what the current step is; Step 1 of 2.
- The input test point value to apply: “Go to 0.000 bar”.
- Completion status at the end of the test.



This primary area of the screen shows the sensor information and readings for Input and Output. The top channel shows the Input information and the bottom channel, the Output information. In the output area, the Error Type is shown below the reading on the right side of the window. For example, ‘% Span’ in the example screen.

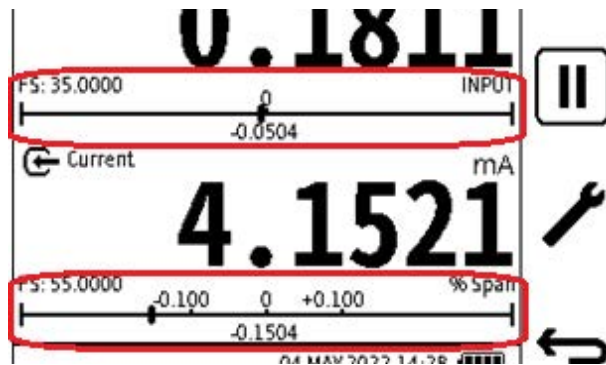

The lower parts of the screen show the error and tolerance indicator is for both the input and the output.

The specified tolerance value is on either side of the zero mark. This value relates to the Error Type and thus is shown as ‘%’. But if the Fixed units Error type is selected, it will be shown in Output measurement units.

The calculated live error is shown below the zero mark in both input and output channels. A marker is also shown: this gives the approximate error value point in relation to the specified tolerance and tolerance line.

Note: If the marker is not shown, look at the error value, as it is likely that the error is too large to be shown by the error and tolerance value.

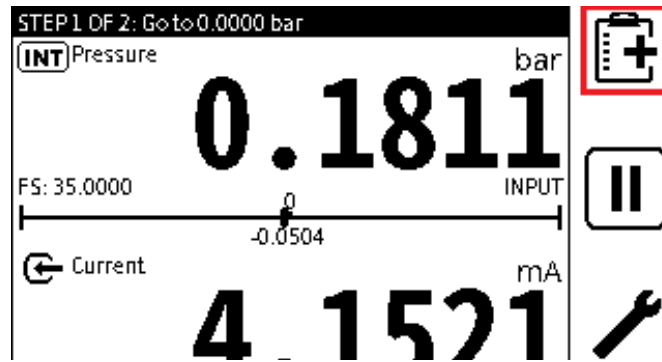

Select the **Add Test Point**  Softkey to record the data point.

12.4 Documenting Settings

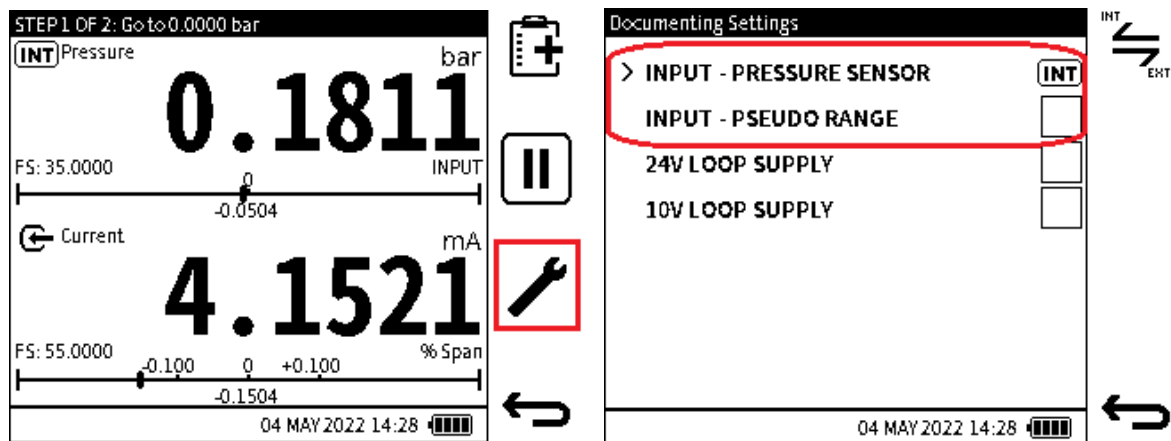

1. If another test procedure setup is necessary before documenting starts, select the **Setup**  Softkey.
2. **Pressure Sensor Type**

For pressure calibrations: it is possible for a pressure sensor type is to be used that is different to the sensor used in the test procedure. This different sensor can be set to be compatible.

Note: This applies to the **INT** and **EXT** Pressure functions used as the Input or/and Output only.

For example, a gauge pressure sensor is used in the test procedure and the available pressure sensor is an absolute pressure sensor. The absolute pressure sensor can be set to pseudo gauge.

To use **PSEUDO RANGE**, select the related pseudo-range option from the settings screen. The tick-box has the tick mark when in operation and has no tick mark when not in operation.

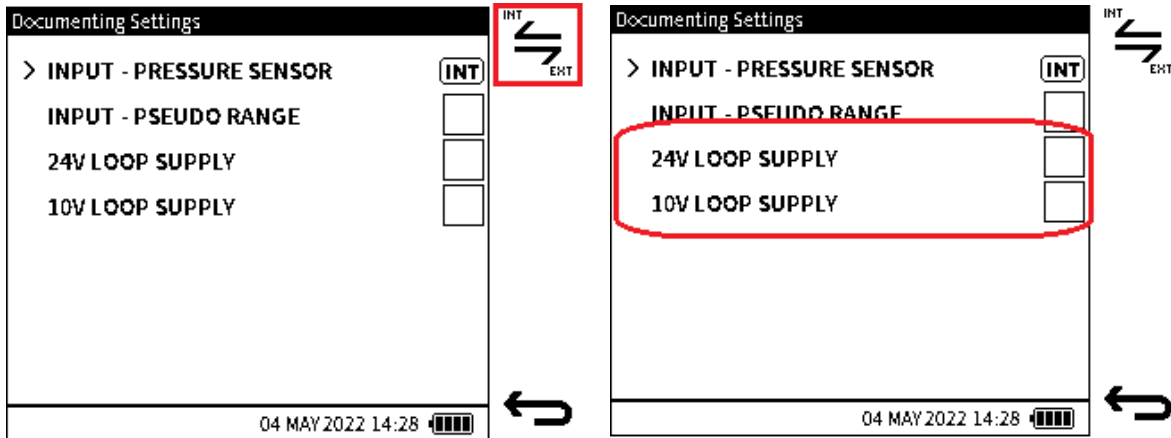

3. **Pressure Sensor Function**

For pressure-to-pressure calibrations: **INT** pressure and **EXT** pressure, it is possible to change the assignments of the sensors as Input and Output by the use of the **Toggle**  Softkey.

Make sure the sensor type and range are compatible with that used in the test.

10 V/24 V Power

Select the necessary option from the **Document Settings** screen.

The checkbox has the tick mark when in operation and has no tick mark when not in operation.

Note: These options are only available when electrical functions are used in the test procedure.

12.5 How to do a Test Procedure

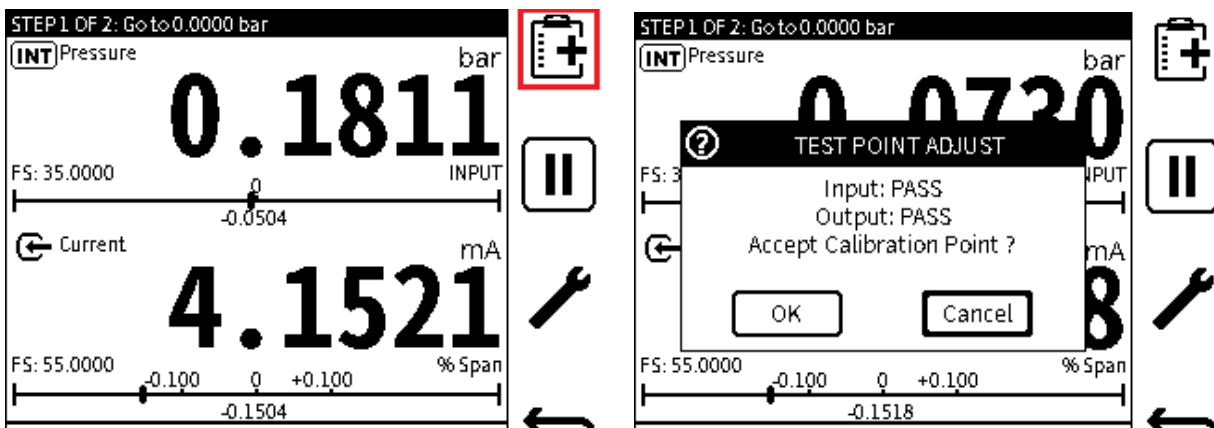

1. Use the step instructions in the title bar, to go to (or input) the Step 1 setpoint value shown. In this example, use the DPI610E pump and/or Volume Adjuster to apply 0.0000 bar.

When the value is in the test point tolerance limits, select the **Add Test Point**  Softkey to record the data point value.

2. The screen shows a popup message window that shows the **Pass/Fail** status of both the input (test point) and the output (result). Select **OK** to accept and save the reading or **Cancel** to reject the reading.

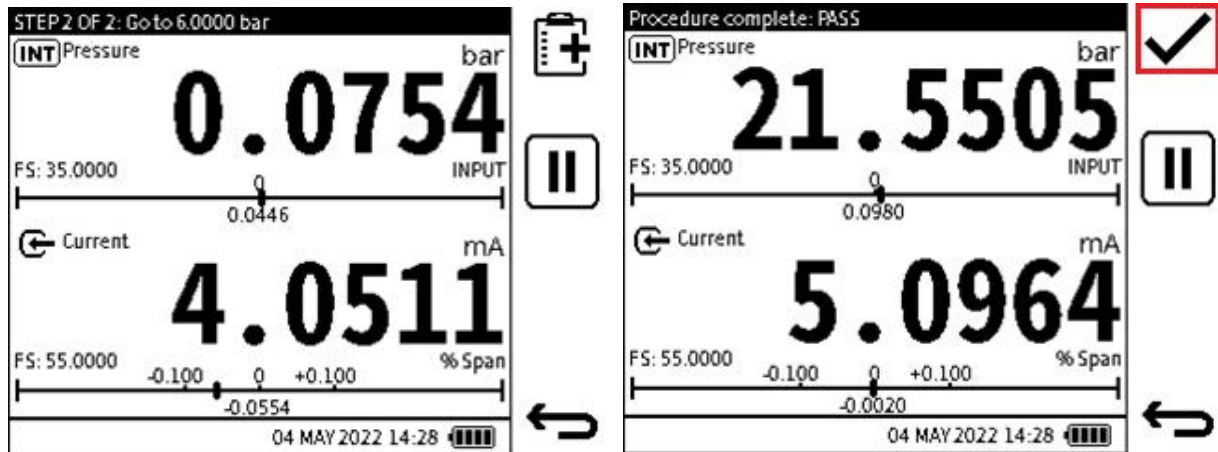

- Go to the next step setpoint as shown in the title bar and do the step again. Do this until all steps have been completed and recorded.
- After the last calibration data point has been recorded, the **Tick** Softkey will replace the **Add Test point** Softkey. The title bar will show **Procedure complete**, together with a **PASS/FAIL**.

Select the **Tick** ✓ Softkey to complete the calibration procedure.

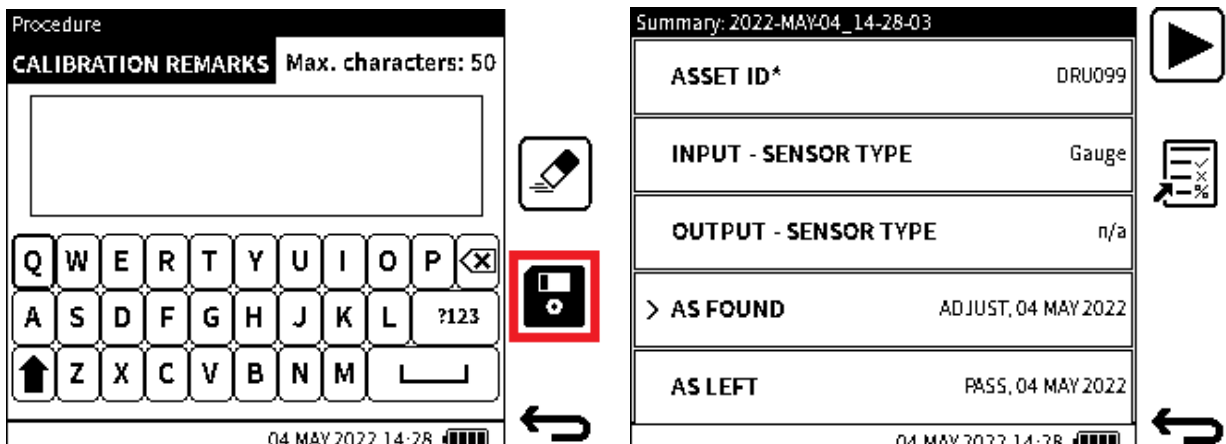

- The following screen is the **CALIBRATION REMARKS** screen. Enter any comments that relate to the completed calibration procedure. This step is optional, and the **CALIBRATION REMARKS** field can be left blank. Maximum number of characters is 50.
Select the **Save**  Softkey to save the **CALIBRATION REMARKS** and continue.
- The next screen is the procedure result Summary screen. This screen gives data about the completed test procedure.

12.6 Post Examination of Test Procedure Results

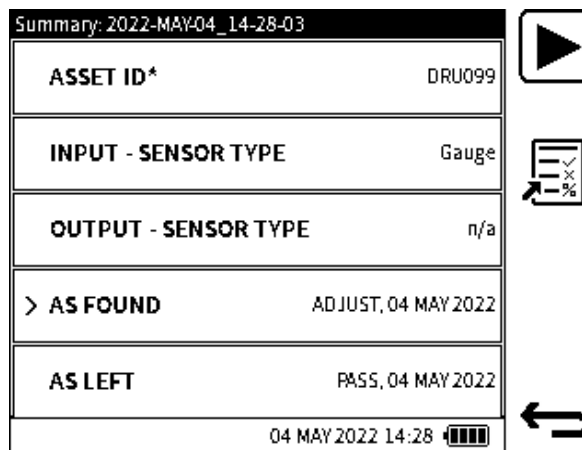

1. When no **As-Found** or **As-Left** results are found for a particular asset, the calibration data will be automatically saved as **As-Found**.

Note: When a test procedure is done on a new Asset for the first time, there will be no **As-Found** or **As-Left** results.

If a **As-Found** or **As-Left** results file is found, then at the end of the test procedure there is the option to save the results as **As-Found** or **As-Left**. The selection **As-Found** will replace old **As-Found** data in memory.

If no **As-Left** data is found, and save as **As-Left** is selected, then a new **As-Left** results file is saved. If an old **As-Left** data file is in memory, then the contents of this file is replaced if the **As-Left** option has been selected.

2. On the **Test Procedure Summary** screen, is the option to do the test procedure again. Push the **Play** Softkey, to use the same test data and device under test (DUT) data.

If you wish to stop, use the **Back** Softkey to go back to the **Internal Files Procedure** menu.

12.7 How to Make an Adjustment on the Device Under Test (DUT)

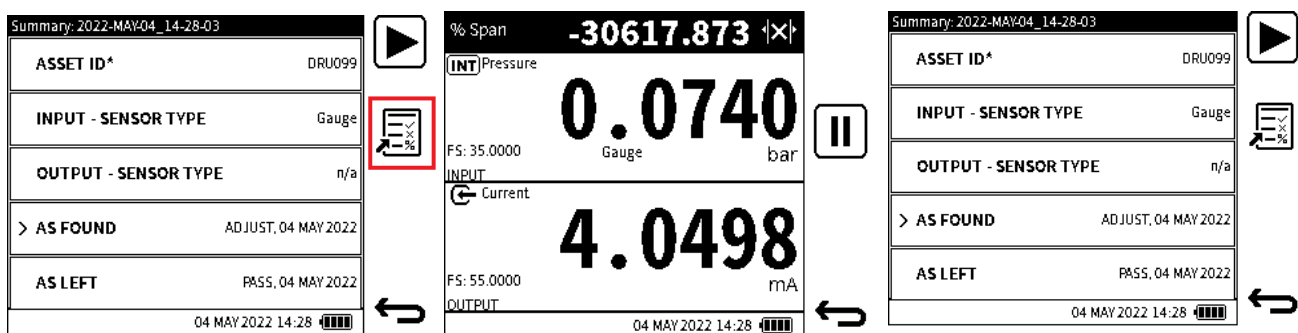

1. It can be necessary at the end of the test procedure, to make an adjustment on the DUT. For example, when the end result of the test procedure is a **Fail**. Then it is possible to use the **Analysis** Softkey, to do a check on the adjustment, to make sure it is correct.
2. Make the necessary adjustment to the **DEVICE UNDER TEST (DUT)**. Examine the output signal through its full calibration range. Do this to make sure it is in specified limits.

When the adjustment is complete, select the **Back**  Softkey to go back to the **Procedure Summary** screen.

- The test procedure can now be done again after adjustment. Select the **Play**  Softkey or icon to do this.

12.8 How to do a Test Procedure Again

The instructions in this section relate to how to do a Test Procedure again for an known asset or Device Under Test (DUT).

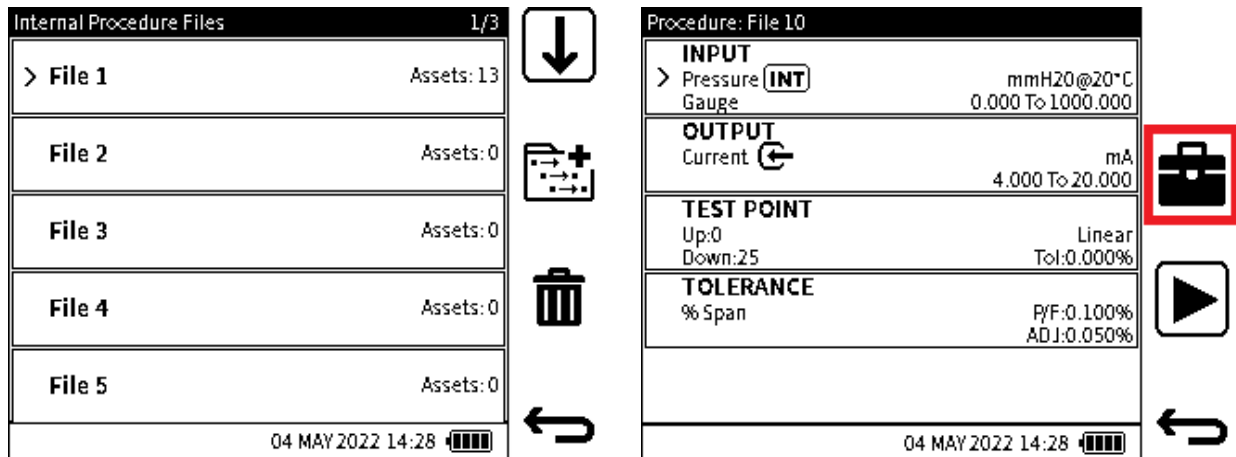

- Select the wanted test procedure file from the list in the **Internal Procedures Files** screen.
- Select the **Briefcase** (Assets)  Softkey to see the asset data, which the test procedure has been done on.

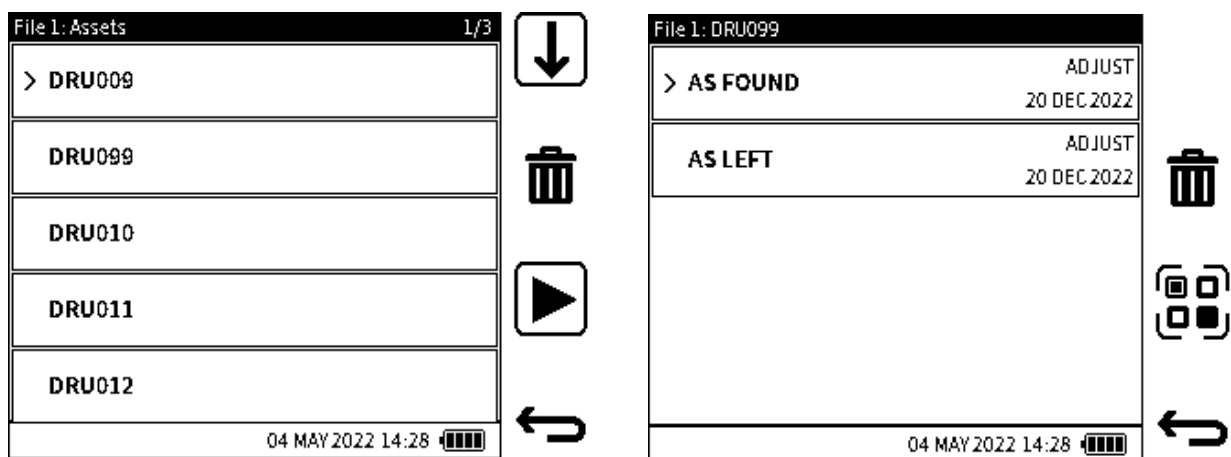

- On the **Assets** screen, see all assets that this specific test procedure has been done on and recorded.

Note: Up to 25 Assets and results can be saved for each calibration test procedure.

To do the test procedure again on the selected asset or Device Under Test (DUT). Select the **Play**  Softkey from this menu screen.

- To look at **As-Found** or/and **As-Left** calibration results, select the wanted Asset file name. Tap the file name to select it and tap a second time to open.

Chapter 12. Documenting

The screen will show available results related to that test procedure and asset.

12.9 How to See Test Results

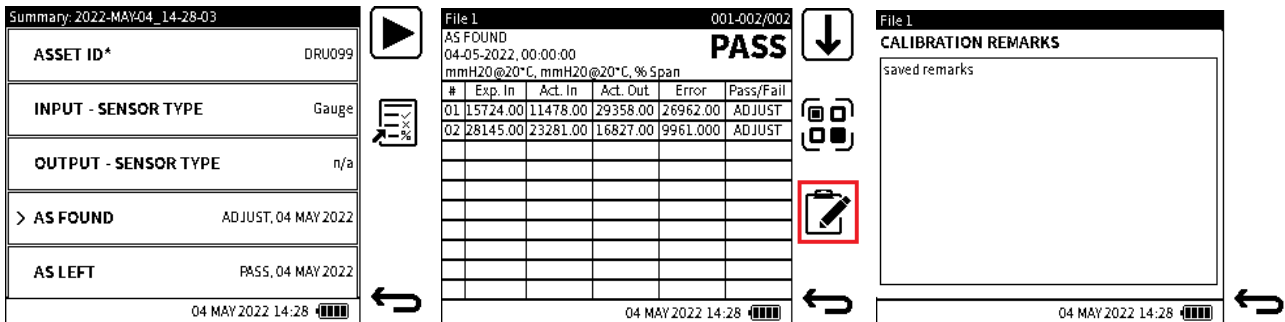

1. Results can be seen immediately after the test procedure is complete. Tap on the wanted result (**As-Found** or **As-Left**) from the procedure **SUMMARY** screen.

Another method to look at the results, is to select the related Test Procedure file and wanted asset file.

2. The calibration test procedure results show the following:
 - Result type – As-Found or As-Left
 - Date/Time – the date and time stamp the calibration procedure was completed
 - Data of the input and output function (Function name and measurement units)

Data details including:

- Input Expected
- Input (Actual)
- Output
- Calculated Error
- Pass or Fail status for each test point
- Pass or Fail Status overall.

To see Calibration remarks that relate to the test, select the **Clipboard**  Softkey.

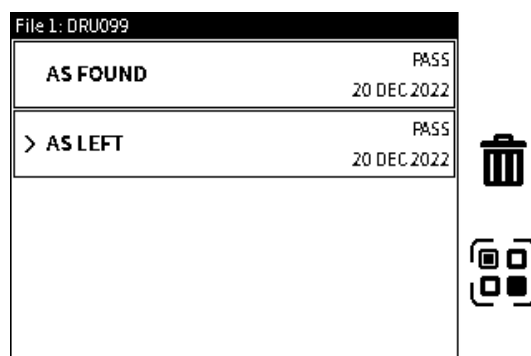

3. Results can also be looked at when, the test procedure is selected, the device under test is selected and then the related test result (**As-Found** or **As-Left**).

12.10 How to Erase Asset Data

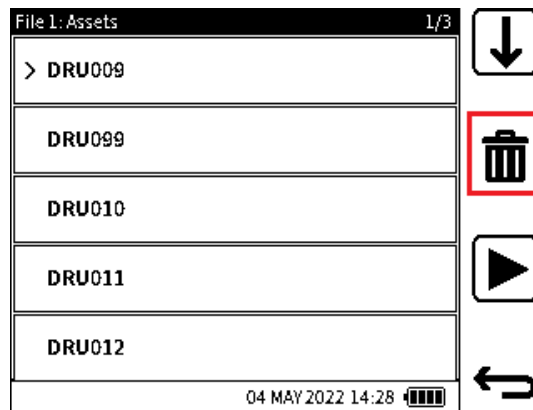

Select the test procedure, then select the asset to be erased, then select the **Delete**  Softkey.

Note: All asset data will be erased.

12.11 How to Use the Calibration Certificate Wizard

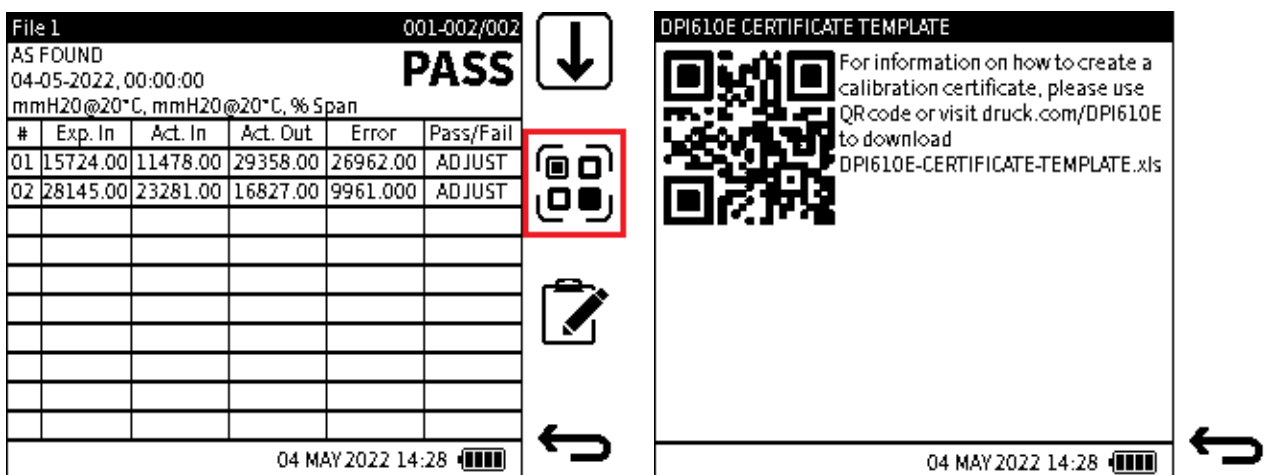

1. Calibration and test procedure data can be the contents of a certificate document. This data is taken from the results of an **As-Found** or **As-Left** asset or Device Under Test (DUT) test. Select the **QR** code Softkey to get access to the QR code for the calibration certificate template.
This template uses the calibration procedure result data as the contents for a formatted calibration certificate.
2. Make a copy of the certificate template and save it by the use of the given URL or QR code.

CALIBRATION CERTIFICATE

Select CSV
Add logo
Export
Reset

DEVICE UNDER TEST

Device Identifier	TN2343
Serial Number	4575262335
Manufacturer	Druck
Model	DP610E-PC
Sensor Type	Gauge

CALIBRATION

Date of Calibration	01-Jun-22
Operator	Robert Smith
Location	Global Star Lab
Ambient Temperature	20.00 °C
Ambient Pressure	1055.82 mbar
Ambient Humidity	70.00%

TEST EQUIPMENT

MAIN CALIBRATOR	Druck
Manufacturer	Druck
Model	DP610E-PC-140
Serial Number	1211908
Date of Calibration	15-Mar-22
Calibration Interval	450 days

ADDITIONAL SENSORS

Manufacturer	Druck
Model	DP610E-PC-140
Serial Number	1222043
Date of Calibration	2-MAR-2022
Sensor Type	Gauge
RANGE	-1.00 to 35.00 bar

RANGE

Input	0.00000 to 24.00000 bar
Output	0.00000 to 240.00000 mV
Relationship	Linear

TOLERANCE

Test Point	5.00 %span
Pass/Fail	0.10 % span
Adjustment	-0.07 % span

#	Expected Input	Actual Input	Expected Output	Actual Output	Error	Status
	CH1	CH1	CH2	CH2	mV	
	bar	bar	mV	mV	mV	
0	0	-0.0031	-0.0312	0.0087	0.00625	PASS
1	1	1.00821	10.08206	10.0066	-0.02965	PASS
2	2	2.0072	20.072	20.0846	-0.0223	PASS
3	3	3.00761	30.07608	30.0322	-0.01786	PASS
4	4	4.00649	40.06486	40.0455	-0.02071	PASS
5	5	5.00426	50.04277	50.05528	0.00521	PASS
6	6	6.0072	60.07204	60.06263	-0.00392	PASS
7	7	7.00295	70.02946	70.0733	0.0827	PASS

- Use a compatible data micro-USB cable to connect the DPI610E to a PC.

Note: Note: Make sure the USB setting is in Storage mode (See Section 4.3 on page 38). Open the Calibration Certificate Template file and tap on the **Select CSV** button. Use the File Explorer to select the DocData folder in the DPI610E mass storage drive. Select the asset result file and then select **Open**.

The calibration data and test procedure data will be put into the template format. To add a logo, select the **Add Logo** cell, select the wanted logo image and select **OK** to use.
- When the calibration certificate has been made, it can then be exported as a PDF file. Use the **Export** button on the template CSV to do this and select a destination file path for it to be saved.

12.12 Remote Documenting

This function lets test procedures made in our 4Sight2 software be downloaded and used on the DPI610E to calibrate devices under test.

4Sight2 offers easy-to-use, cost effective and scalable calibration management with full integration with Druck Calibrators. All this gives: seamless communication, end-to-end automation, a paperless calibration process and increased efficiency.



The 4Sight2 software is available on the Druck website www.druck.com/4sight2 and is free to download and use (trial or Freemium version).

To download test procedures from 4Sight2 on to the DPI610E, use the supplied USB data cable to connect the instrument to the PC.

Note: This function is not available for use with the DPI610E-A (Aero).

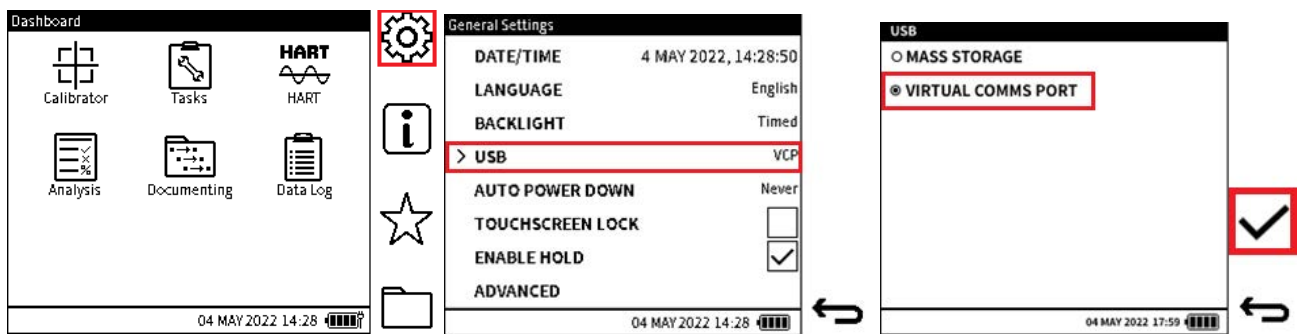
12.12.1 Setup and Connection.



1. Select the **Settings**  Softkey on the Dashboard.
2. Select the **USB** option.
3. Select the **VIRTUAL COMMS PORT** option if it is not already selected, then select the **Tick**  Softkey to confirm completion of the selection.

The 4Sight2 software and the Druck CommServer must install correctly for the DPI610E to successfully connect to the 4Sight2 software.

Start the **4Sight2** application on your system.

From the 4Sight2 Dashboard, select the **Assets** tab to get access to **Asset and Work List** information. Select the **Work List** tab to look at the calibrations that have to be completed. (For more information on how to create Assets or Work List items, please refer to the 4Sight2 Calibration Management Software User Manual 123M3138).

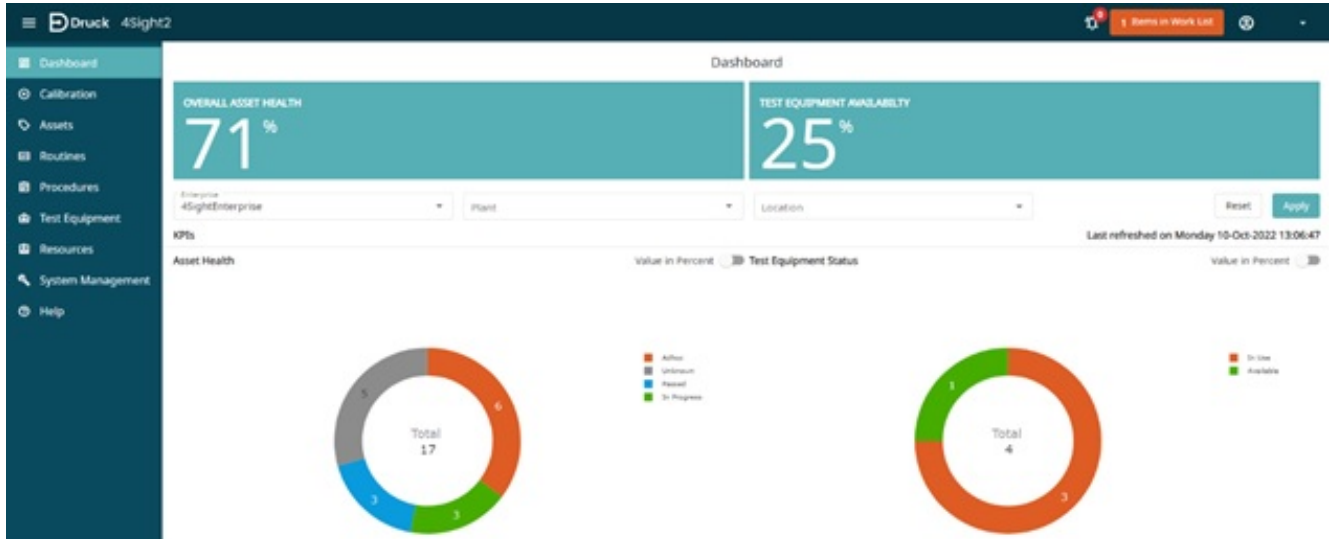

From the 4Sight2 work list, select the calibration procedure(s) to be done. Select the **Portables** calibration type option and tap the **Send** button.

Chapter 12. Documenting

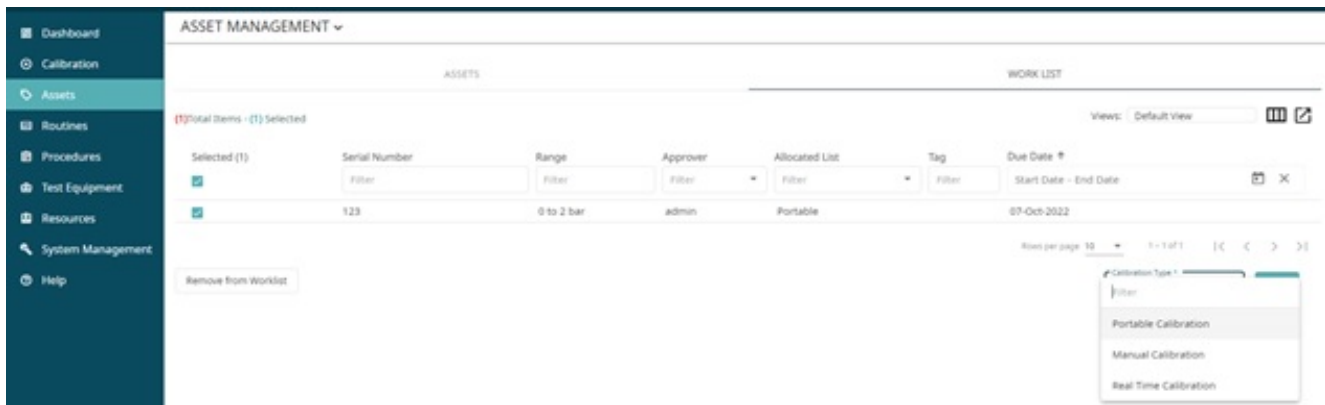

Go to the **Calibration** tab and tap **Portable Calibration**. The calibration procedure(s) already selected, will be in the Portable Calibration list.

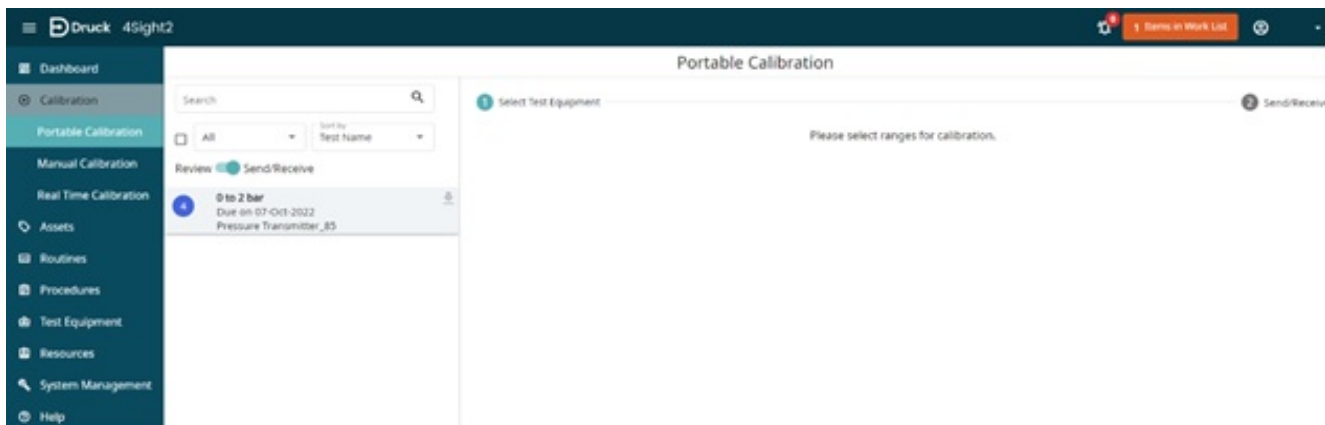

Select the wanted procedure to continue. Make sure the Port is set to **USB**. If the **Test Equipment** drop-down box is empty, select **Get Connected Test Equipment**. This will start the connection to the DPI610E.



Note: If errors occur when a connection to the DPI610E is done, make sure the DPI610E is plugged in and in Virtual Communications Port (VCP) mode. If the Druck Comms Server is not installed and in operation, the connection cannot occur.

After successful connection to the DPI610E test equipment, select the **Test Equipment** drop-down box to select the sensed device (shown by its model and serial number).

Make the Test Equipment profile: enter data into the data fields in the popup screen and tap the **Create** button to complete the procedure.



Select the **Continue** button to continue.

Set the Ambient / Environmental parameters in which the calibration is to occur. It is possible to change these parameters when the calibration is started.

Select the Calibration Test Procedure(s) to be sent to the DPI610E and tap **Send to Test Equipment**.

When the procedure is completed, a **Success** message will be in the **Operation Status** tab.

Chapter 12. Documenting

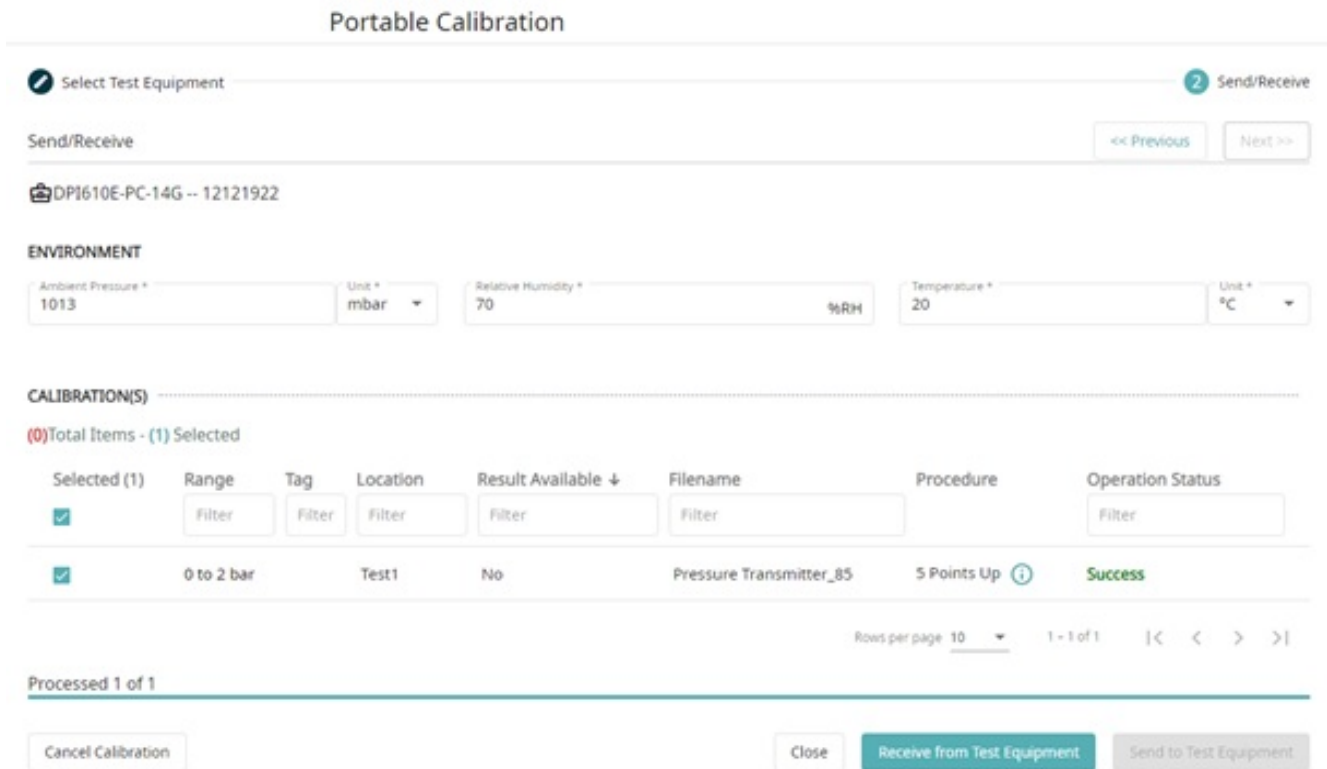

Note: Copies of tests that have special or Asian characters in the file name cannot be sent to the DPI610E. Accented letters or characters in the file name must be replaced by alternative characters without the accent symbols.

12.12.2 How to use 4sight2 (Remote) Calibration Test Procedures

On the DPI610E, select **REMOTE PROCEDURES** from the **Procedures** menu and tap again (or push the **Enter** button if using the Navigation Pad) to open.

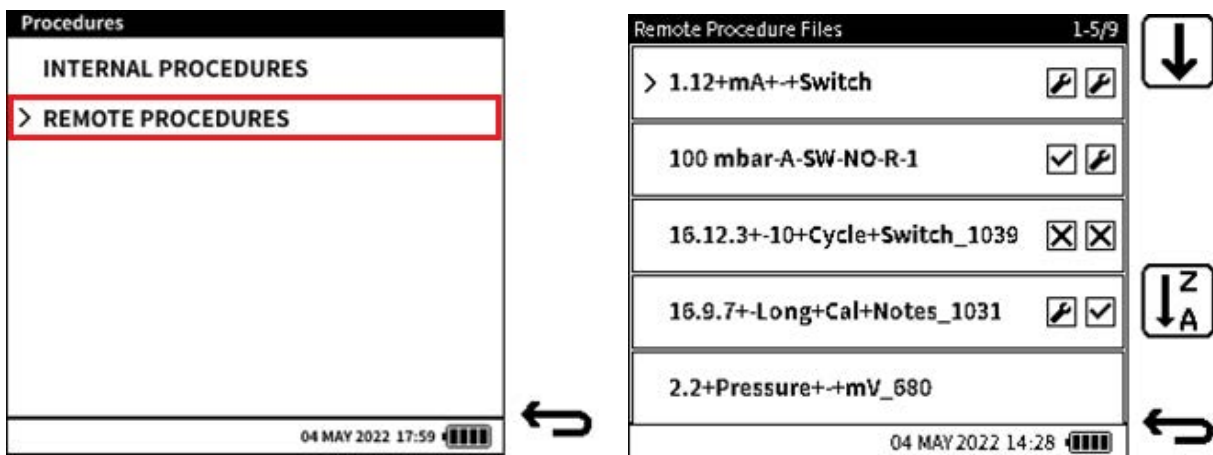

1. On the DPI610E, select **REMOTE PROCEDURES** from the **Procedures** menu.
2. Select the wanted Remote test procedures from the **Remote Procedure Files** screen.

Use the  icon to show the next page of files.

Use the  icon to set the order in which the files are listed.

Tap on the row to open the procedure (or use the **Enter**  button in the Navigation Pad). The DPI610E has two types of remote test procedures available:

- Linear or Proportional Test Procedure.
- Switch Test Procedure.

12.13 Linear or Proportional Test Procedure

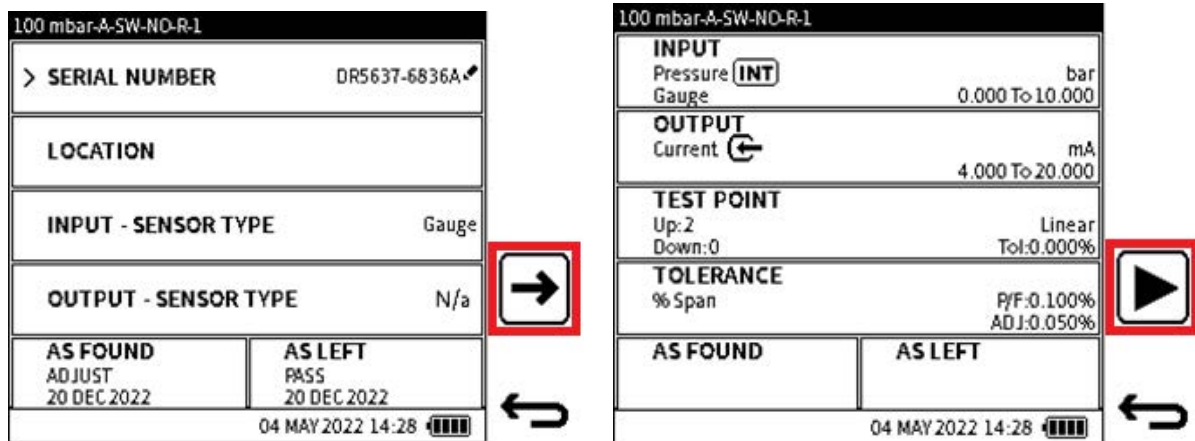

1. When a Proportional test procedure is selected from the **Remote Procedures** menu, the test procedure file data are as shown in the Step 1 figure. If necessary, only the Device Under Test (DUT) serial number information can be changed.

Make sure that the data are correct, then select the **Next**  Softkey to see the test information.

2. Make sure that all the test information is correct, then push the **Play**  Softkey to start the calibration procedure. See Section 12.2.2, “How to Make an Internal Procedure,” on page 172.

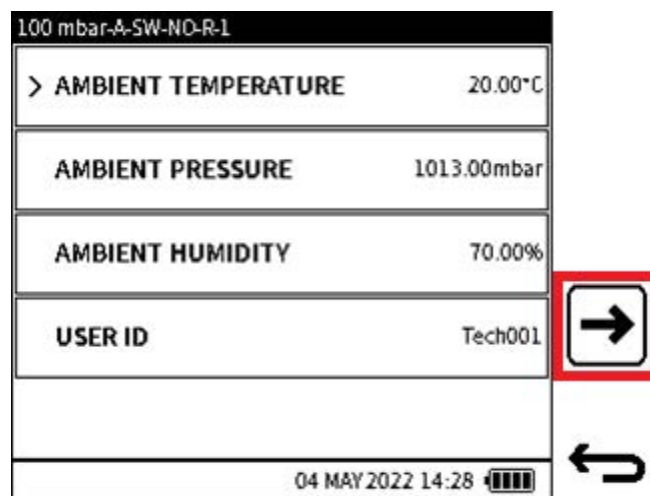

3. Examine and change, if necessary, the environment data and user ID.

Push the **Next**  Softkey to go to the next step.

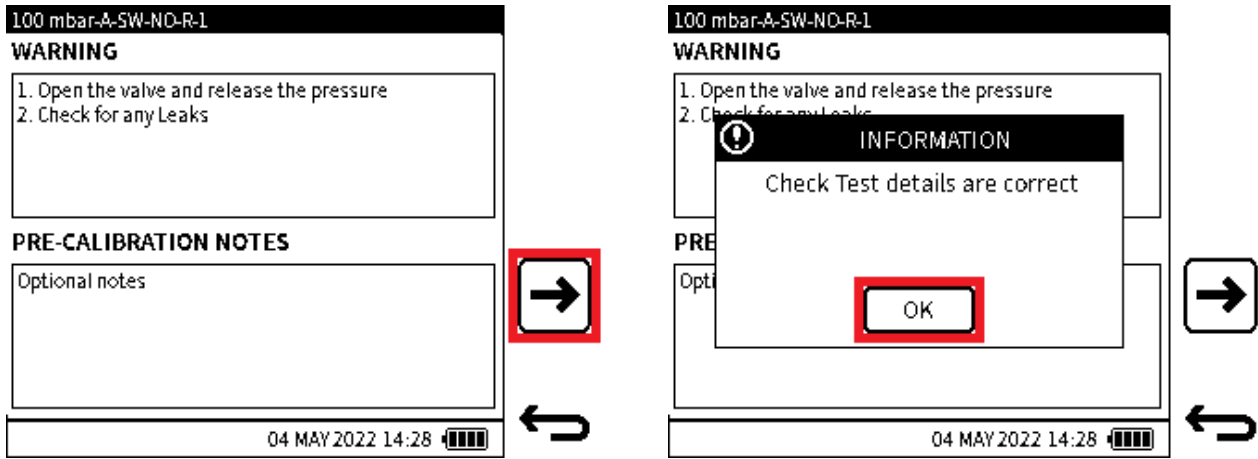



- A screen with **WARNING NOTES** appears and the **PRE-CALIBRATION NOTES** as set in 4Sight2. This screen shows read-only information.

Select the **Next**  Softkey.

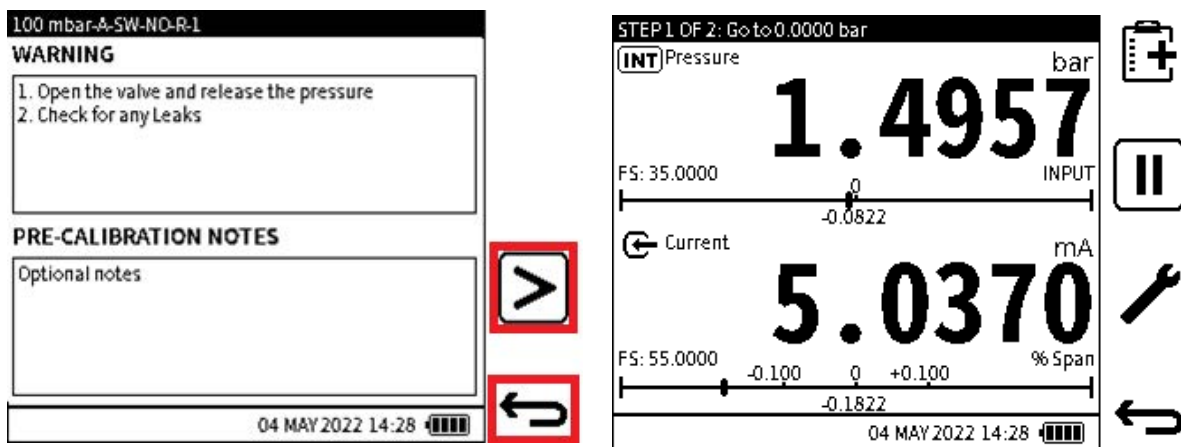
The screen then shows a popup message. Select the **OK** button to accept the test data as correct and close this popup window.



- The available selection is either to go back to the test information by the use of the **Back**  Softkey, or if the test data are satisfactory, select the **Proceed**  Softkey to show the test screen.
- On the test screen, follow the instructions on the top bar, to complete the calibration test procedure. Refer to Section 12.5 on page 186 for an example of how to do a test procedure.
Note: See Section 12.3, “The Documenting Main Screen,” on page 183 for more information about the test screen and Section 12.4, “Documenting Settings,” on page 185 for more information about available settings.

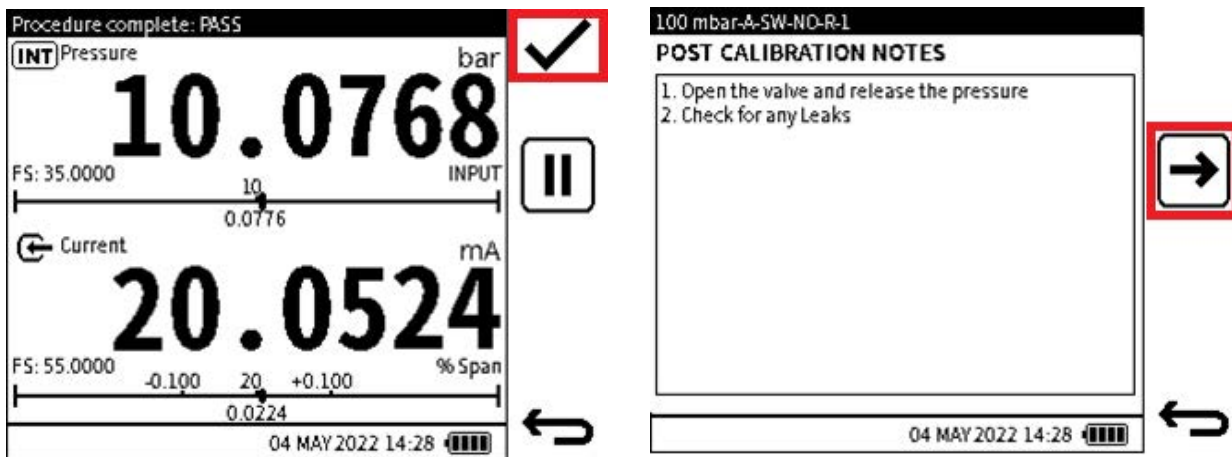

- After the last calibration data point has been recorded, the **Tick** Softkey replaces the **Add Test Point** Softkey.

The title bar will show “Procedure complete” with the test result status. Select the **Tick** Softkey to complete the calibration.

- The POST CALIBRATION screen gives the necessary information to know after the calibration ends.

This information is read-only and set with 4Sight2.

Select the **Next** Softkey to show the **CALIBRATION REMARKS** screen.

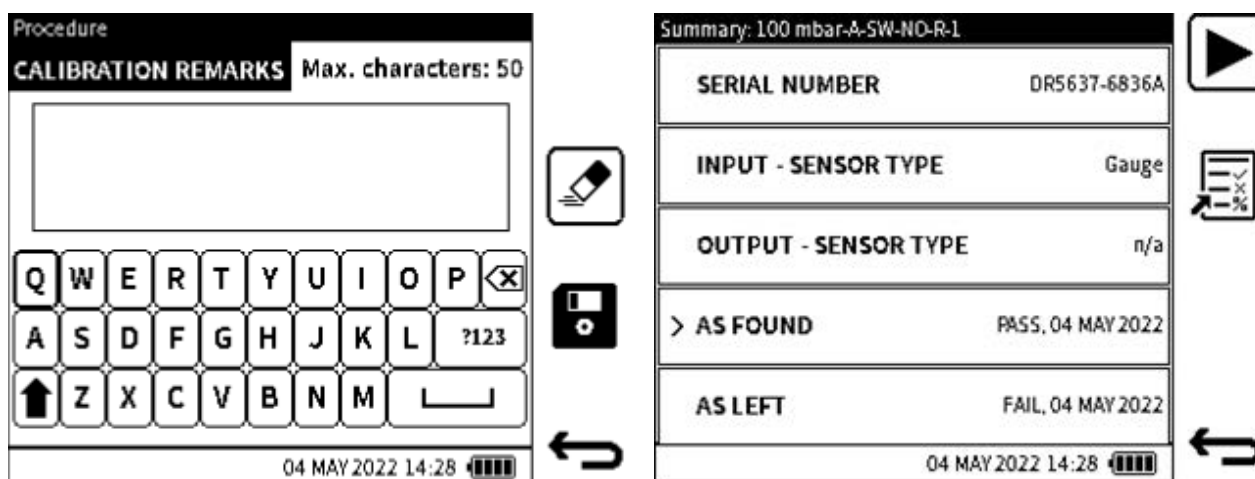

- Enter comments that relate to the calibration procedure completed. This step is optional, and the **CALIBRATION REMARKS** field can be left empty. Maximum number of characters: 50.

Select the **Save** Softkey to save the **CALIBRATION REMARKS** and continue.

- The next screen is the Summary screen.

Note: When a test procedure is done on a new Asset for the first time, there will be no **As-Found** or **As-Left** results.

When no **As-Found** or **As-Left** results are sensed for an asset, the calibration data will be automatically saved as, **As-Found**.

Chapter 12. Documenting

If only an **As-Found** results file is found, then at the end of the test procedure, the results will be automatically saved as **As-Left**.

If both **As-Found** and **As-Left** result files are in the memory when the test procedure is used again, the content of the **As-Left** results file will be replaced.

It is possible on the **Test Procedure SUMMARY** screen, to use the test procedure again.

Push the **Play**  Softkey to do this. The procedure will use the initial test data and device under test (DUT) data.

To stop the use of the screen, use the **Back**  Softkey to go back to the **Remote Procedure** menu.

12.14 Switch Test Procedure

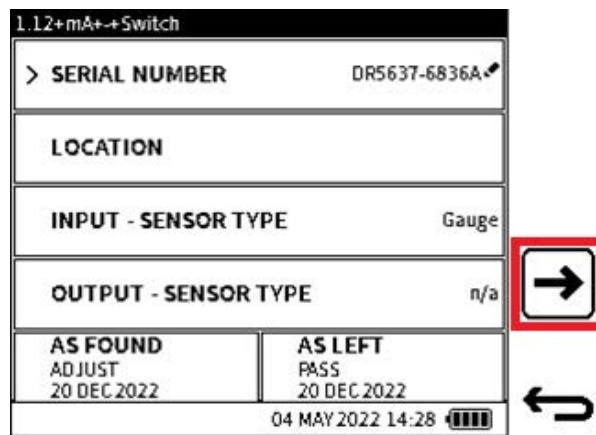

1. When a **Switch Test** procedure is selected from the **Remote Procedures** menu, the screen shows data from the test procedure file. Only the Device Under Test (DUT) **SERIAL NUMBER** data can be changed on this initial screen.

Make sure that the data are correct, then select the **Next**  Softkey to look at the test information.

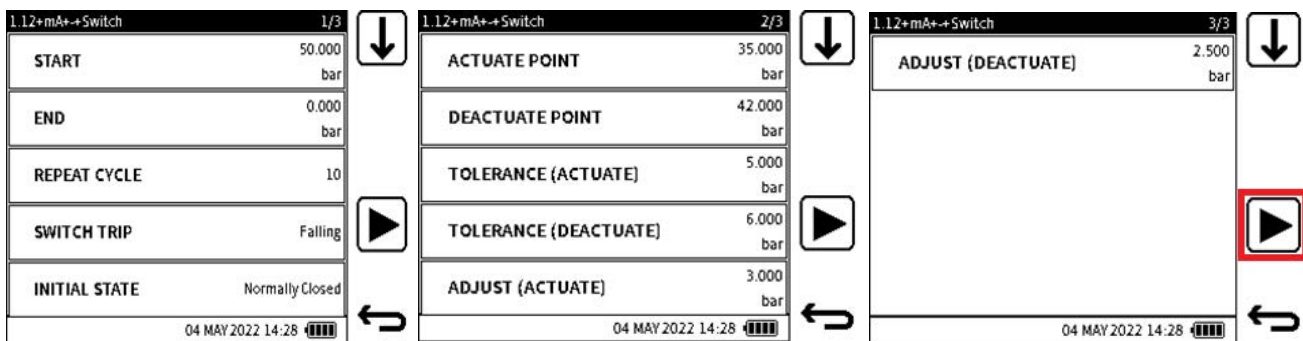

2. The Switch Test information is given by three screen pages that give the following settings as set in 4Sight2:
 - **START** - the start-pressure value for the switch test before the pressure ramp operation.
 - **END** - the end-pressure value of the switch test.
 - **REPEAT CYCLE** - the number of switch test cycles to be completed in the test procedure in a set sequence.

- **SWITCH TRIP** - the direction of pressure to make the pressure switch operate.
- **INITIAL STATE** - the initial mode of the pressure switch (its condition before a change in pressure makes it operate). This is either **Normally Open** or **Normally Closed**.
- **ACTUATE POINT** - the pressure for an actuator or pressure switch DUT to start to operate (actuate).
- **DEACTUATE POINT** - the pressure for an actuator or pressure switch DUT to switch off (de-actuate).
- **TOLERANCE (ACTUATE)** - the maximum pressure deviation for the operation of an actuator or trip pressure switch DUT. If the pressure is in specification (=PASS) or out of specification (=FAIL).
- **TOLERANCE (DEACTUATE)** - the maximum pressure deviation for the de-activation of an actuator or trip pressure switch DUT. If the pressure is in specification (=PASS) or out of specification (=FAIL).
- **ADJUST (ACTUATE)** - the maximum deviation of the actuating or trip point pressure value in the PASS/FAIL tolerance. This shows that the pressure switch DUT is near to out-of-specification limits.
- **ADJUST (DEACTUATE)** - maximum deviation of the de-actuating or reset point pressure value within the PASS/FAIL tolerance. This shows that the pressure switch DUT is near to out-of-specification limits.

Make sure that all the test data is correct, then push the **Play**  Softkey to start the calibration procedure. See Section 12.2.2, “How to Make an Internal Procedure,” on page 172.

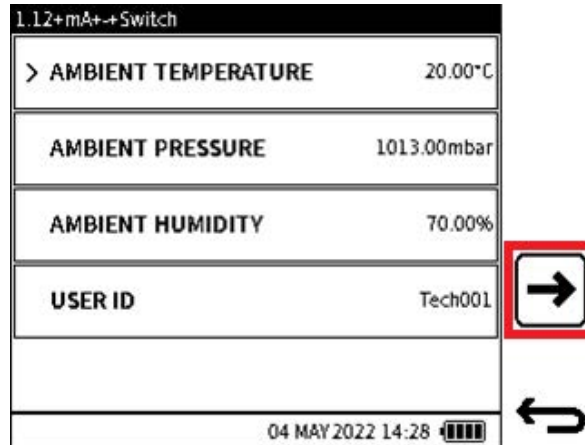

3. Examine and change, if necessary, the environment data and **USER ID**.

Push the **Next**  Softkey to go to the next step.

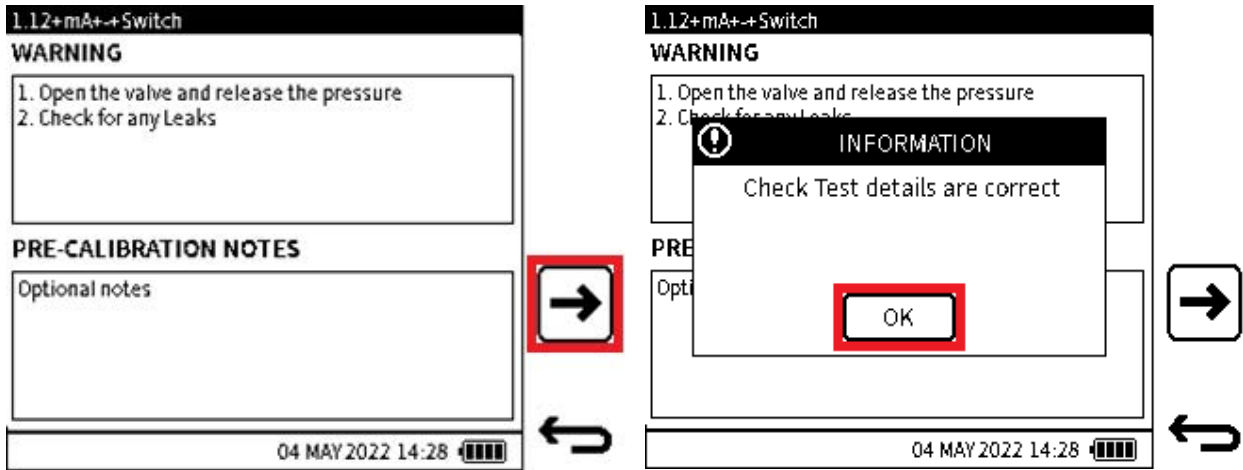



4. This screen shows **WARNING NOTES** and the **PRE-CALIBRATION NOTES** as set in 4Sight2. This screen shows read-only information.

Select the **Next**  Softkey to show the test screen.

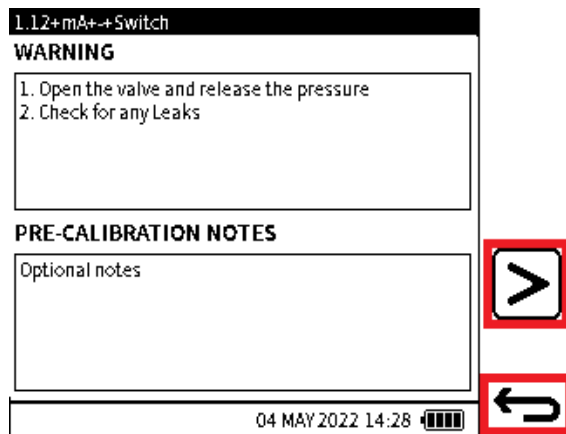
The next screen shows a popup message. Select the **OK** button to tell the system that the Test data are correct and to remove this popup message.



5. Use the **Back**  Softkey to go back to the test information or use the **Proceed**  Softkey to show the test screen.

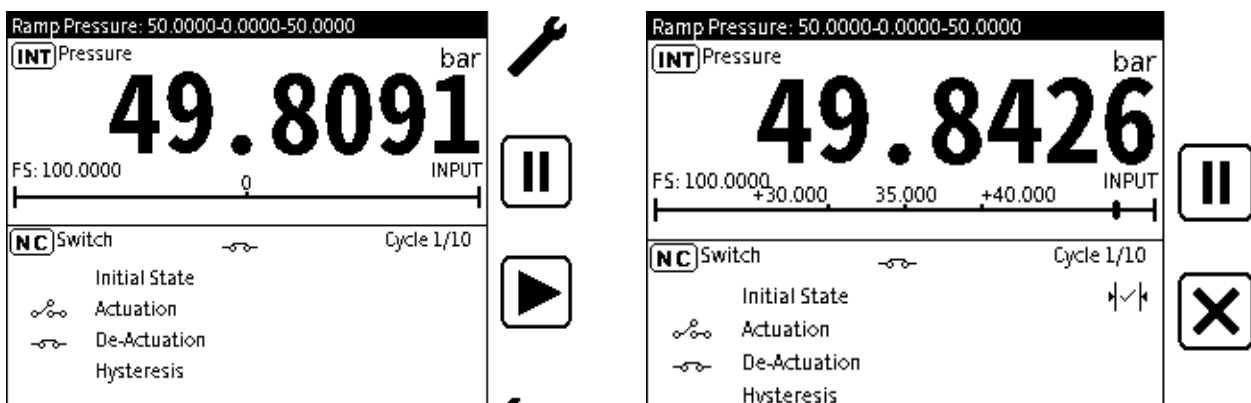

- On the test screen, follow the instructions on the top bar to complete the calibration test procedure. For a Switch Test procedure, the screen will show the Ramp start and end pressure in the top bar.

The top channel shows the Input pressure applied to the switch DUT. The bottom channel shows the switch data.

The mode of the live switch is shown at the top of the switch channel. The switch test cycle mode is shown at the top right corner of the switch channel ("Cycle 1/10"). The switch test results show the following data for each test cycle:

- Actuation pressure value with PASS/FAIL status.
- De-actuation pressure value with PASS/FAIL status.
- Hysteresis value.

Note: See Section 12.3, "The Documenting Main Screen," on page 183 for more information about the test screen and Section 12.4, "Documenting Settings," on page 185 for more information about the other settings available.

To start the Switch Test, make sure that the applied pressure is at the Ramp start value before the selection of the **Play**  Softkey.

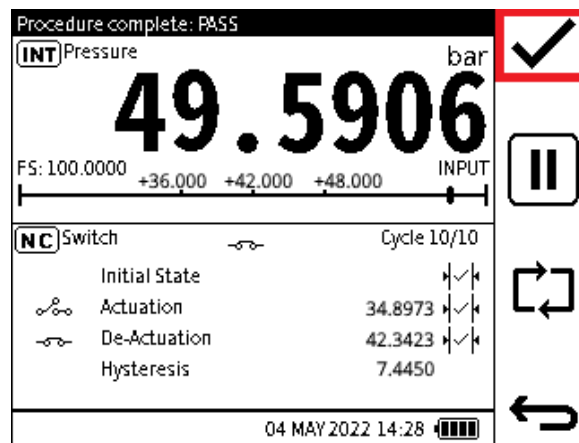

- After the last switch test cycle has been completed, the **Tick** ✓ Softkey will replace the **Add Test Point**  Softkey. The title bar will show Procedure complete with the overall test result status. Select the **Tick** Softkey to fully complete the calibration procedure.

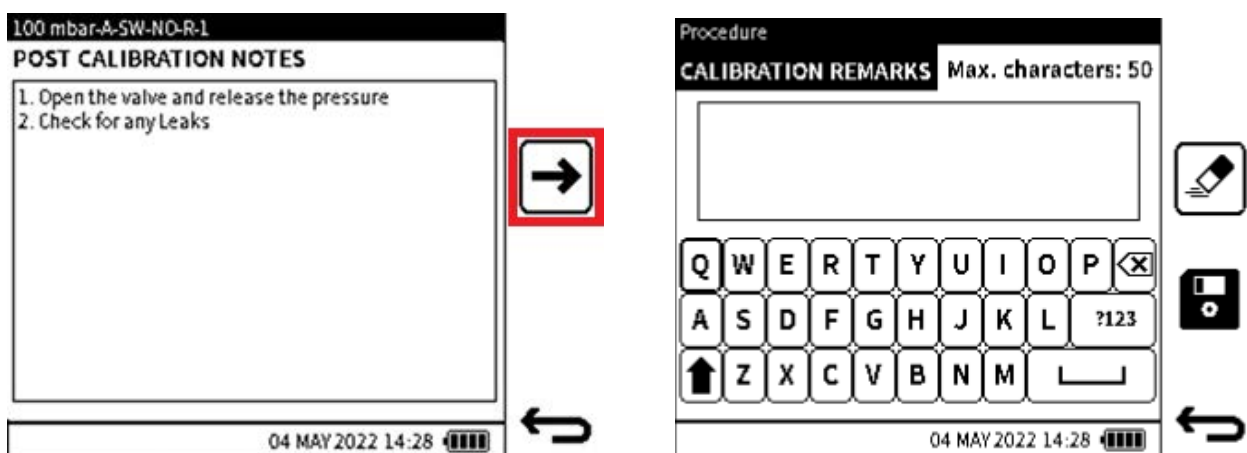

Chapter 12. Documenting

- The **POST CALIBRATION** screen gives necessary information to have, after the calibration has been done. This information is read-only and set by 4Sight2. Push the **Next**  Softkey to go to the next screen.
- Enter into this screen, if wanted, comments that relate to the completed calibration procedure. This step is optional: the **CALIBRATION REMARKS** field can be left empty. Maximum number of characters: 50.

Select the **Save**  Softkey to save the **CALIBRATION REMARKS** and continue.

Summary: 1.12+mA+-+Switch	
SERIAL NUMBER	DR5637-6836A
INPUT - SENSOR TYPE	Gauge
OUTPUT - SENSOR TYPE	n/a
> AS FOUND	ADJUST, 04 MAY 2022
AS LEFT	FAIL, 04 MAY 2022
04 MAY 2022 14:28 	



- The Procedure result **SUMMARY** screen shows data related to the last completed test procedure.

Note: Note: When a test procedure is done on a new Asset for the first time, there will be no **As-Found** or **As-Left** results.

When no **As-Found** or **As-Left** results are found for an asset, the calibration data is automatically saved as, **As-Found**.

If only an **As-Found** results file is found, then at the end of the test procedure, the results are automatically saved as **As-Left**.

If both **As-Found** and **As-Left** result files are in the memory when the test procedure is used again, the content of the **As-Left** results file will be replaced.

It is possible on the **Test Procedure SUMMARY** screen, to use the test procedure again.

Push the **Play**  Softkey to do this. The procedure will use the initial test data and device under test (DUT) data.

To stop the use of the screen, use the **Back**  Softkey to go back to the **Remote Procedure** menu.

12.15 How to Do an Adjustment on the Device Under Test (DUT)

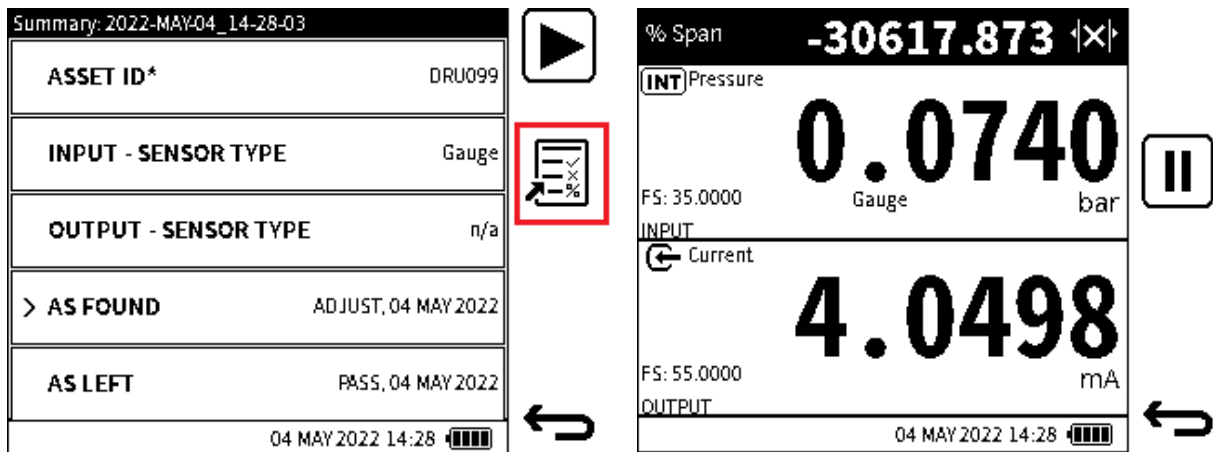



1. An adjustment can be necessary at the end of the test procedure. For example, if the end result of the test procedure is a **Fail**.

It is possible to do an adjustment and examine its effect, by the use of the **Analysis**  Softkey.

2. Make the necessary adjustment to the Device Under Test (DUT). Examine the output signal through its entire calibration range. Do this to make sure it is in the limits before the calibration test procedure is done again.

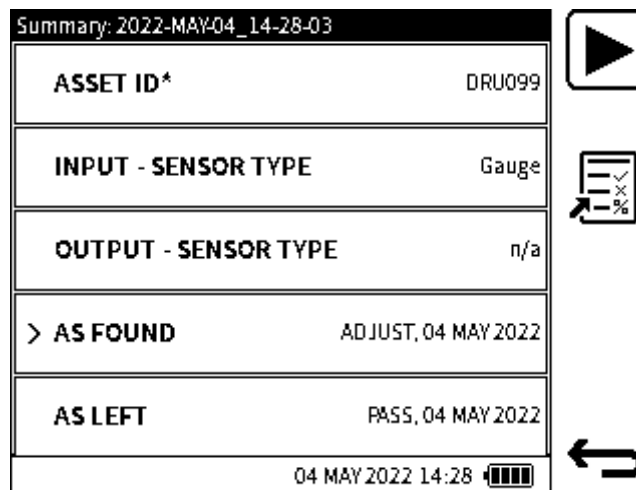
When the adjustment is complete, select the **Back**  Softkey to go back to the **Procedure Summary** screen.



3. The test procedure can now be done again after adjustment. Select the **Play**  Softkey or icon to do this.

12.16 How to View Test Results

Tap on the wanted result row (for example, **As-found** or **As-Left**) to see a screen of results immediately after the test procedure is completed.

Results can also be looked at when the test procedure is selected and also the related test result, for example, **As-Found** or **As-Left**.

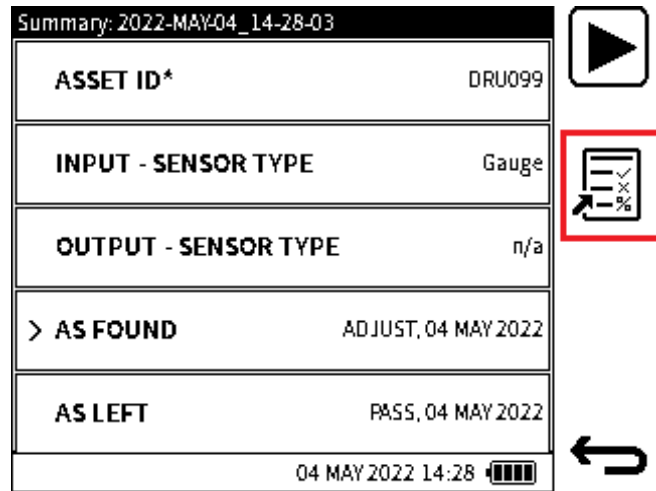

1. An adjustment can be necessary at the end of the test procedure. For example, if the end result of the test procedure is a **Fail**.

It is possible to do an adjustment and examine its effect, by the use of the **Analysis**  Softkey.

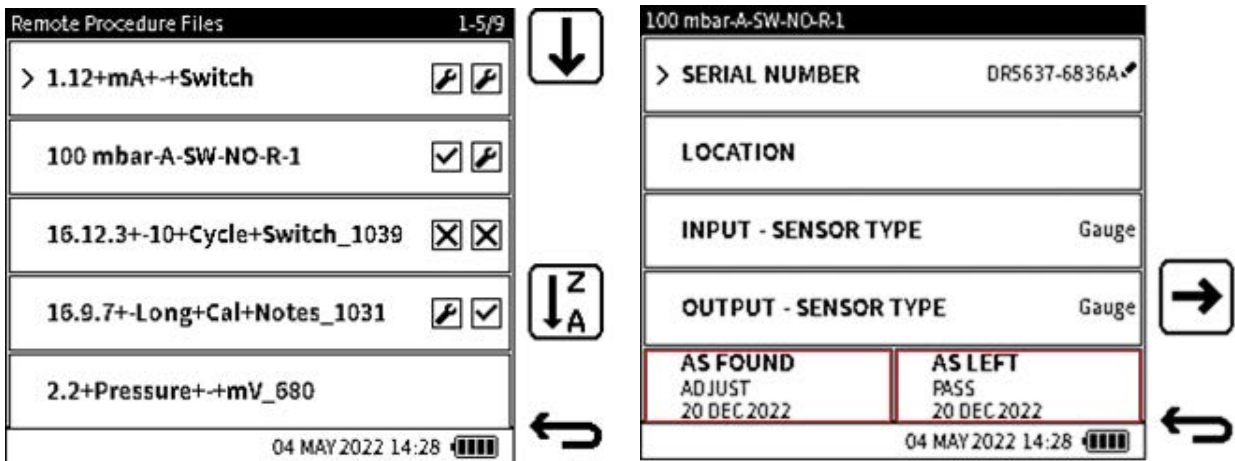

2. Use the  icon to show the next page of files.

Use the  icon to set the order in which the files are shown.

Note: A visual indication of test results is given in the **Remote Procedure Files** menu, next to each procedure file name. If no icons are shown, it means no results are available for that test procedure. The first icon shows the **As-Found** result and the second icon shows the **As-Left** result.

 - FAIL INDICATION

 - ADJUST INDICATION

100 mbar-A-SW-ND-R-1						001-002/002
AS FOUND						ADJUST
04-05-2022, 00:00:00						
mbar, mbar, % Span						
#	Exp. In	Act. In	Act. Out	Error	Pass/Fail	
01	31928.00	25423.00	28520.00	6902.000	ADJUST	
02	24596.00	3737.000	13261.00	10195.00	FAIL	
04 MAY 2022 14:28						



1.12+mA+-+Switch		1/17
AS FOUND		PASS
04-05-2022, 00:00:00		
mbar		
Switch Test Cycle		1
Units		mbar
Test Result		ADJUST
Initial State		ADJUST
Actuate		18087.000000
Actuate Error		31060.000000
Actuate Result		FAIL
Deactuate		9010.000000
Deactuate Error		4757.000000
Deactuate Result		ADJUST
04 MAY 2022 14:28		



3. The calibration test procedure results for Proportional Test Procedure show the following:
 - Test Procedure/Asset ID
 - Result type - As-Found or As-Left
 - Date/Time - the date and time the calibration procedure was completed
 - Input and Output measurement units
 - Error type
 - Test point #
 - Expected (Specified) input for each test point
 - Actual (Recorded) input for each test point.
 - Calculated error or deviation
 - Pass/Fail/Adjust result.

4. The results of calibration test procedure from the Switch Test Procedure, show the following:
 - Test Procedure/Asset ID
 - Result type - As-Found or As-Left
 - Date/Time - the date and time the calibration procedure was completed
 - Switch Test Cycle number
 - Pressure measurement units
 - Initial Switch State (Mode)
 - Actuation and De-actuation Pressure
 - Actuation and De-actuation Error
 - Actuation and De-actuation Result
 - Pass or Fail result for each test cycle.

Note: For Switch Test with multiple switch cycles, use the **Page Down** Softkey to see the test results of each cycle.

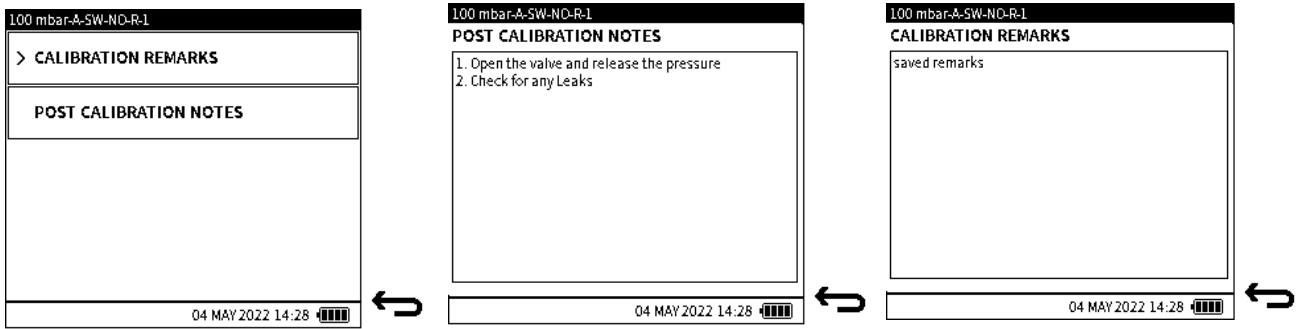

- To see **CALIBRATION REMARKS** or **POST CALIBRATION NOTES** that relate to the test, select the **Clipboard** Softkey from the results screen and select the wanted option.
Use the **Page Down** Softkey and **Back** Softkey to move between screen pages.

12.17 How to Erase Remote Procedure Files

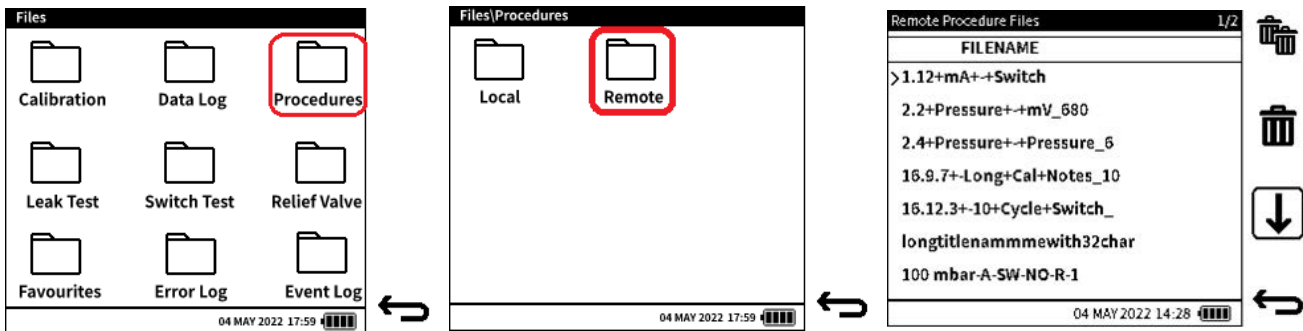

- To erase **Remote Procedure** files, use the **File System** Softkey on the Dashboard. Select the **Procedures** folder and then the **Remote** sub-folder.
- From the list of procedure files, tap on the wanted file to erase and select the **Single Delete** Softkey to erase this file. To erase all files present, select the **Delete All** Softkey.

12.18 Uploading Test Results To 4Sight2

Note: The DPI610E must be in VCP mode and connected to the PC.

To copy test results back to 4Sight2:

From the related Calibration screen in 4Sight2, select the wanted calibration and tap **Receive from Test Equipment**. The success of the copy operation will be shown by the “Success...” text in the Operation Status area.

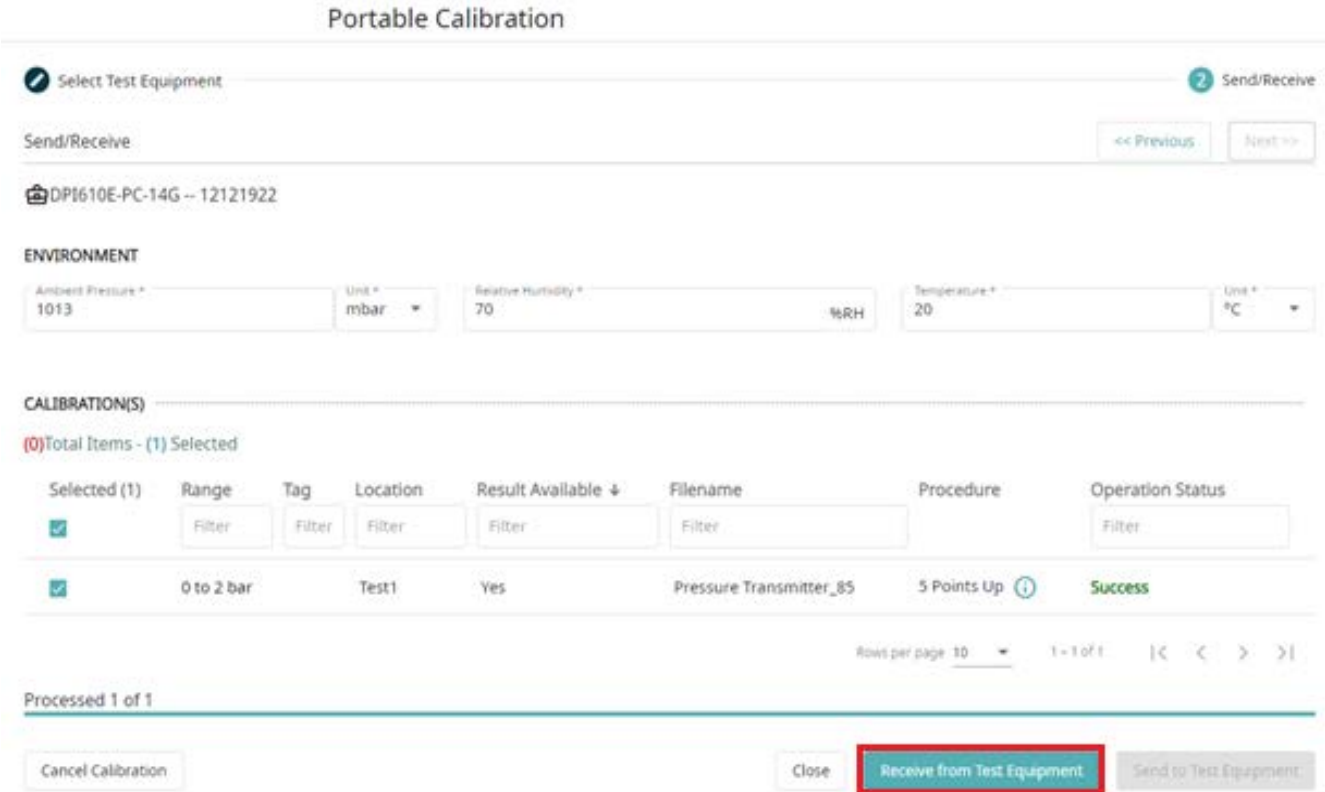

To see the results, tap on the toggle icon in the left-hand section of the screen to change from **Send/Receive** to **Review** mode.

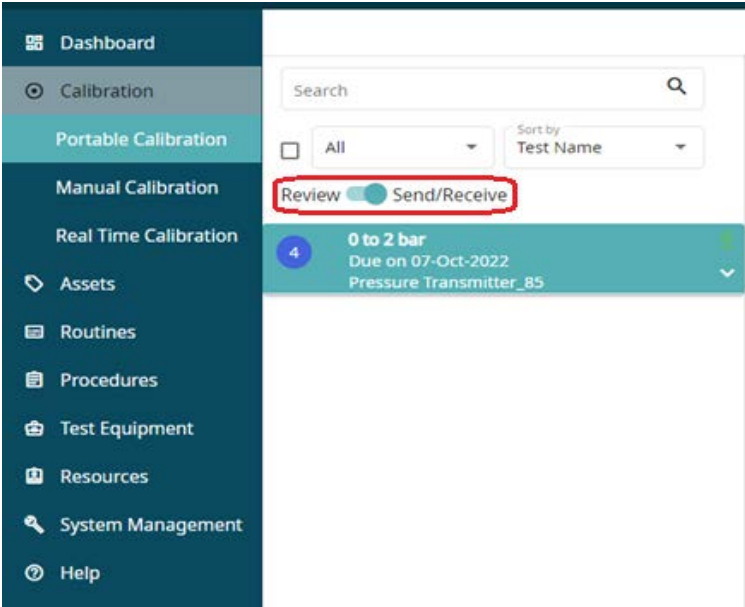

Select the calibration file to show data of the test and its results.

Chapter 12. Documenting

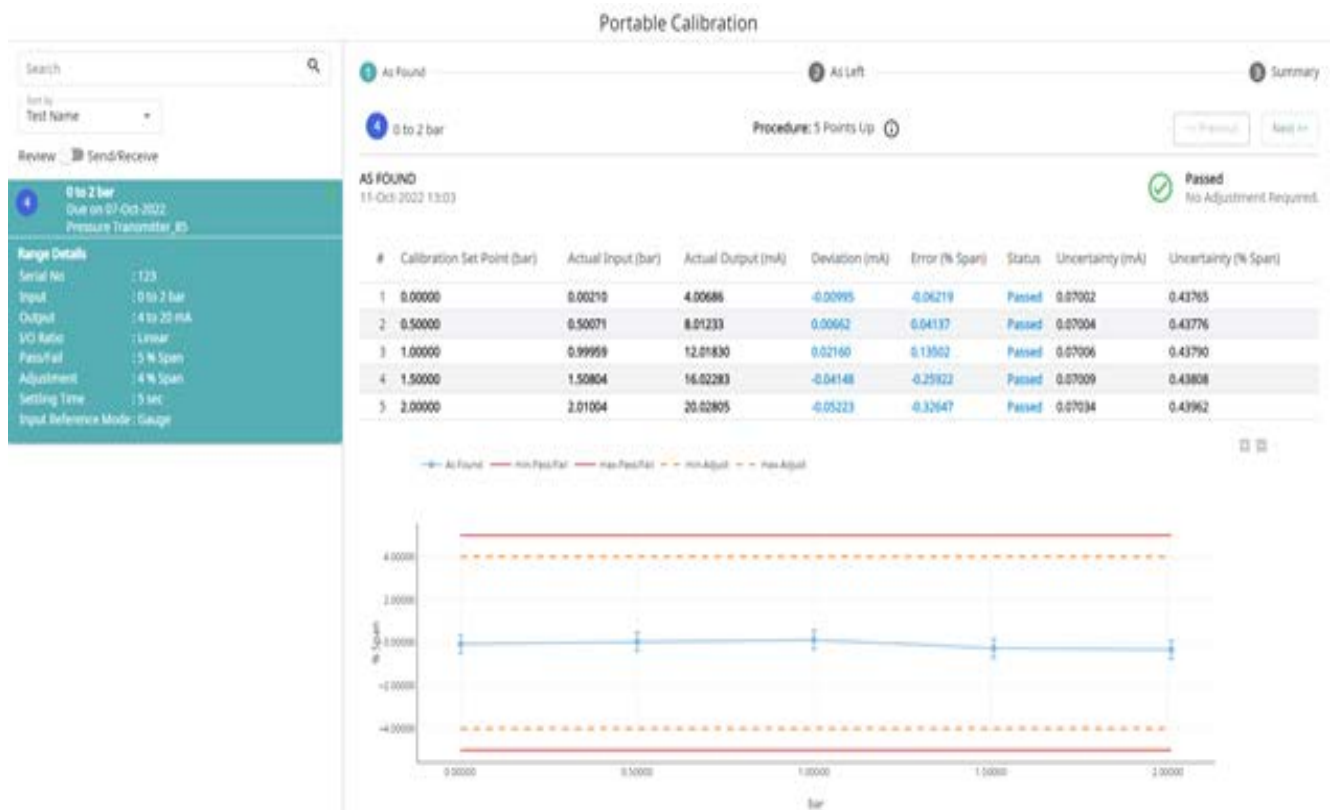

For more information on how to analyze or use test data in 4Sight2, please refer to the 4Sight2 User Manual **123M3138**.

13. HART

13.1 HART® Application

The DPI610E can use the HART® (Highway Addressable Remote Transducer) data transfer protocol. This protocol lets the DPI610E do basic HART operations and set other HART supported devices. The HART bidirectional data transfer technology operates as a master/slave protocol. When the DPI610E connects to a HART device, the DPI610E operates as the master and the HART device as the slave. The DPI610E uses the functions from the Universal and Common Practice commands specified in HART revision 5, 6 and 7.

The HART function is only available on **CH2**. This function uses the current loop signal for the transfer of its data: the DPI610E can give a 24 loop power supply to the HART Device if necessary. The DPI610E can also use a 250 ohm HART resistor: this gives the voltage drop necessary for HART communication.

The DPI610E can be used to move data for HART devices as a:

Primary Master - the DPI610E starts and controls all movement of data. The field device (slave) uses each instruction from the master device to make a change and/or send data back.

Secondary Master - the DPI610E connects to a HART data network. The Secondary Master moves data with the field device between Primary Master messages.

13.1.1 How to Start the HART Application (Method 1)

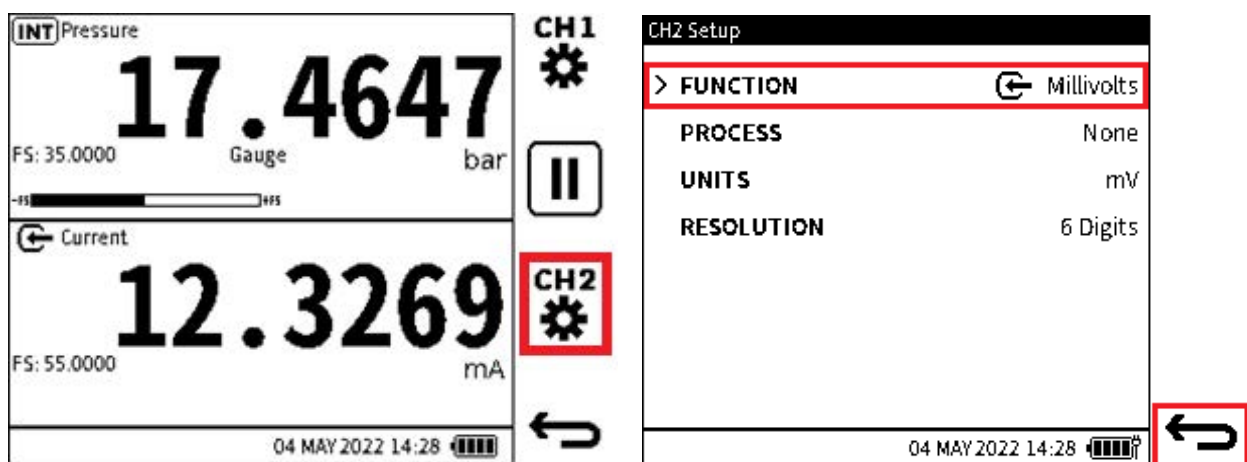



1. From the **Calibrator** screen: select the channel 2 ^{CH2} **Setup** (either tap the screen icon or push the Softkey).

Note: The **HART** function is only available on **CH2**.

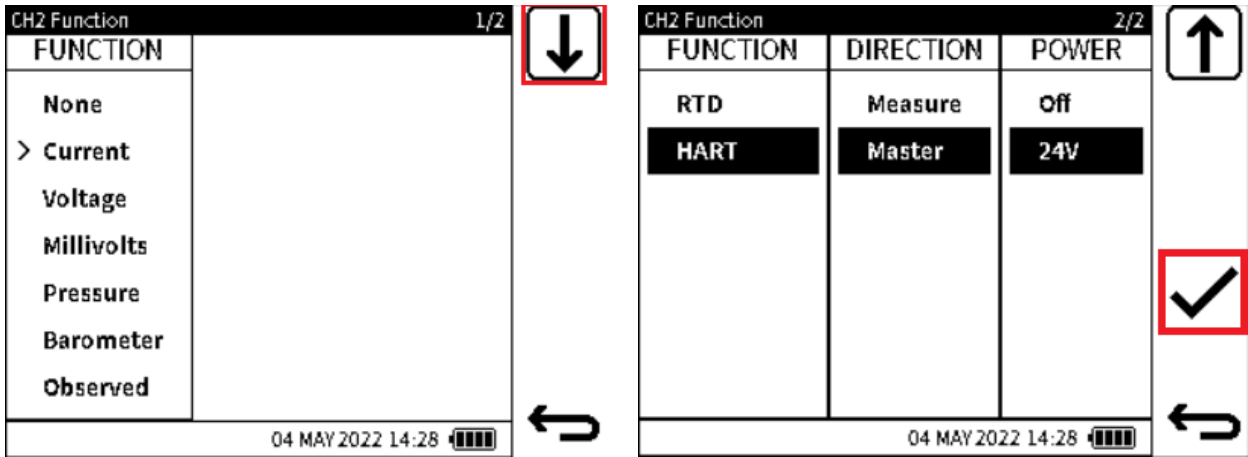
2. Select **FUNCTION** from the **CH2 Setup** screen.



3. Select the **Page Down**  Softkey to see the second page of **CH2** functions.
4. Select **HART** in the **FUNCTION** column.
 Select the wanted **DIRECTION** (**Measure** or **Master**).
 Select the loop **POWER** option (**Off** to use an external power supply or **24V** to use the DPI610E internal power supply).
 Select the **Tick**  icon to make the selection and set the instrument.

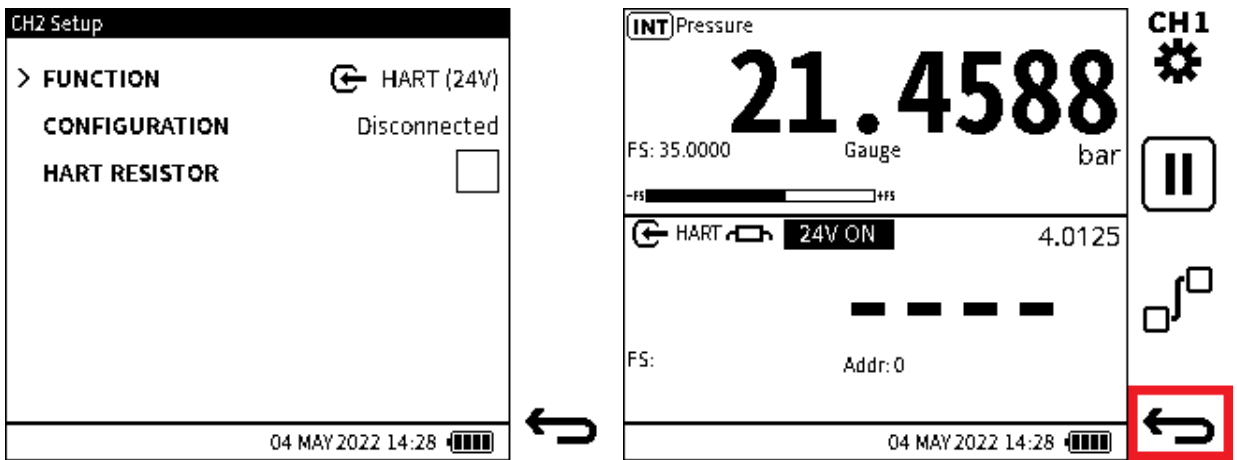

5. The **CH2 Setup** screen shows the **HART** function.
 The **CONFIGURATION** mode is also shown (if a **HART** device is connected or disconnected). See Section 13.2 on page 214 for Configuration information.
 When selected (checkbox ticked), the 250 ohm HART resistor option lets the DPI610E make available the resistor internally.
 If the instrument connects directly to a network, there must be a 250 ohm resistor connected in series with the loop power supply and the **HART** device. Here the **HART** resistor is unavailable in the setup (checkbox must be empty).
Note: the 250 ohm HART resistor is important for data movement with the HART device to occur. It gives sufficient impedance in the signal loop for the HART signal to occur.
6. Select the **Back**  Softkey to go back to the Calibrator screen.

HART is set in CH2.

13.1.2 How to Start the HART Application (Method 2)

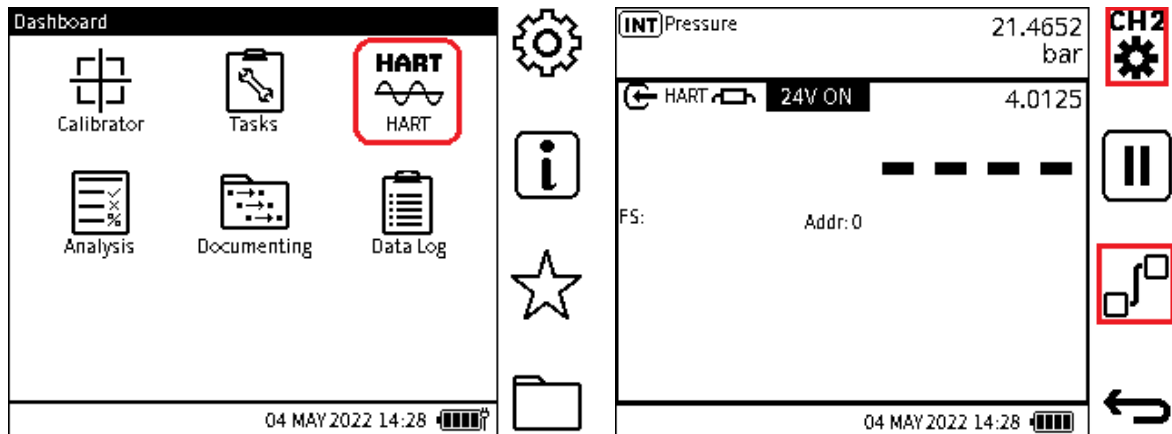

1. Select the **HART** icon on the **Dashboard** screen. Tap on the HART icon or use the keypad to select the icon and the **OK** button to start the application.

This second method is a quicker method to set the channel with HART. But, the HART application will use the default or last saved setup. If different settings are wanted, then use Method 1 to make changes.

2. Tap in the **HART** bottom screen area to maximize the window and show the **CH2** icon. Select the  icon to show the **CH2 Setup** screen.

To set the HART function, use the procedure in Section 13.1.1 on page 211 from step 2 forwards.

Select the **Configuration**  Softkey to start data movement between the instrument and the **HART** device.

13.1.3 HART Device Electrical Connection

The **Help**  button on the DPI610E shows information about the different electrical connections shown. See section 13.1.1 for setting the loop power.

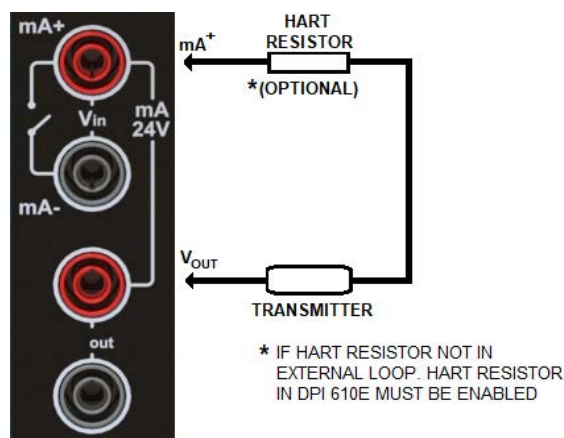

HART with internal 24 V loop power available. This is when the menu selection is: **HART > Measure > 24V**.

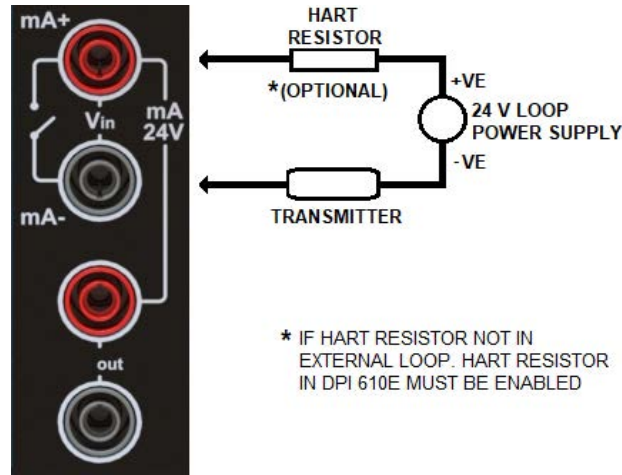

HART with external loop power (internal loop power not available). This is when the menu selection is: **HART > DIRECTION > Measure > Off.**

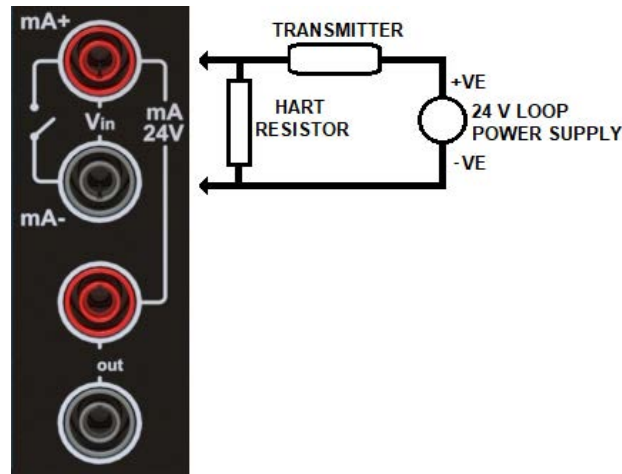

HART when connected to an external current loop. This is when the menu selection is: **HART > DIRECTION > Master.**

13.2 HART Device Configuration

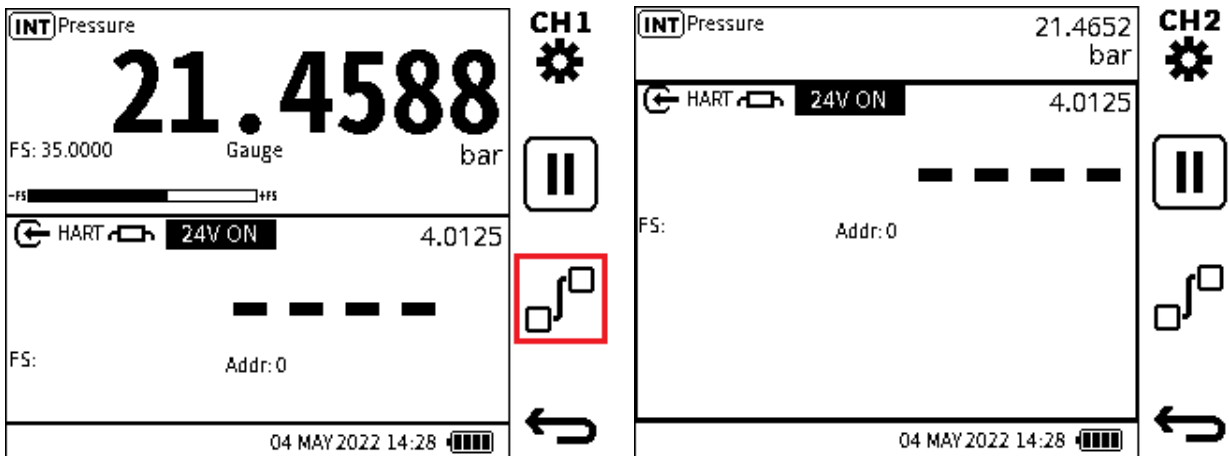

- The measured loop current (Measure mode) or 'secondary reading' of a connected HART device (Master mode), will usually be the current used by the DPI610E. This value is shown as the secondary reading in the **CH2** window.

To start data movement between the instrument and the **HART** device, select the

Configuration  Softkey.

Note: When the **HART** device has no data movement with the DPI610E, the screen will show in the primary reading area a set of dashed lines (-----) that move.

- Another method to get access to the **Configuration** menu is to do it from the **CH2 Setup** screen.

Note: If the **HART** application is in operation, maximize the **CH2** window to get access to the **CH2 Setup** Softkey.

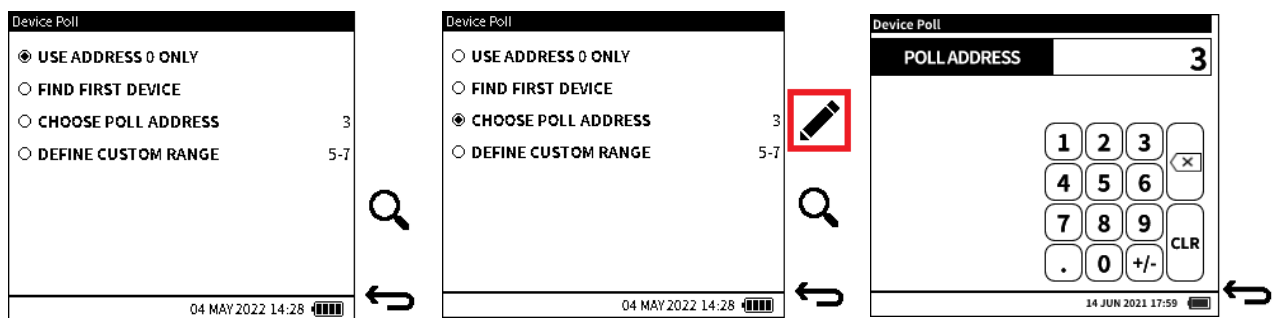



- The connected **HART** device can be given a special Poll Address, only for that device. The setup screen gives selections for the **HART** device. Select one of the following Device Poll methods:

- USE ADDRESS 0 ONLY** - Search for connected devices that have Poll Address 0 only.
- FIND FIRST DEVICE** – Search for the full Poll Address range (0 to 63) and identify the first device found.
- CHOOSE POLL ADDRESS** – Look for one user-specified Poll Address.
- DEFINE CUSTOM RANGE** – Look for a user-specified Poll Address range.

When the **CHOOSE POLL ADDRESS** is selected, the Poll Address number to look for must be entered.

The default is 0.

To change the Address value, select the **Edit**  Softkey and enter the wanted value. Push the **Tick**  Softkey to accept and the **Back**  Softkey to go back to the **Device Poll** screen.

Note: An applicable Poll Address value must be between 0 and 63.

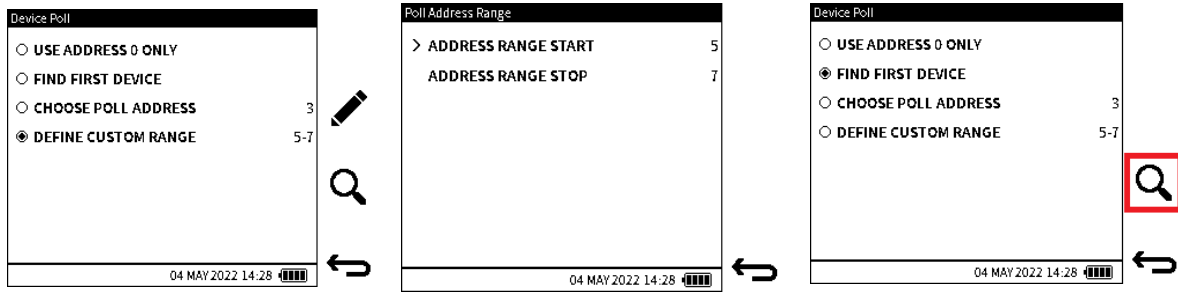

The Poll Address range must be specified when the **DEFINE CUSTOM RANGE** option is selected.

The default value from 0 to 63.

To change the Address range, select the **Edit** Softkey and enter the wanted **START** and **END** value. Push the **Tick** Softkey to accept and the **Back** Softkey to go back to the **Device Poll** menu.

Note: An applicable Poll Address range must be between 0 and 63.

When the wanted Poll method has been set, select the **Search** Softkey to start.

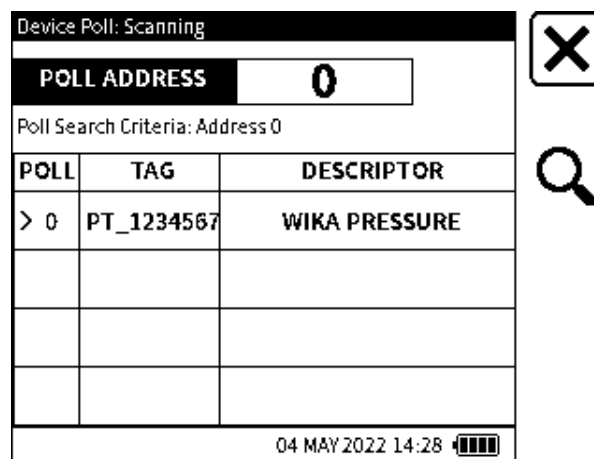

The **Device Poll** screen has the following:

- The Title bar shows the Device Poll status. This is either Scanning or Scan Complete.
- The Poll Address that is to be found.
- Poll Search method or criteria.
- The Search result table, that shows the Poll Address, Tag and Descriptor of the device when successfully found. It can show a maximum of four found devices.

The scan operation can be stopped immediately if necessary, by the use of the **Stop** Softkey.

Select the **Search** Softkey to start the scan again.

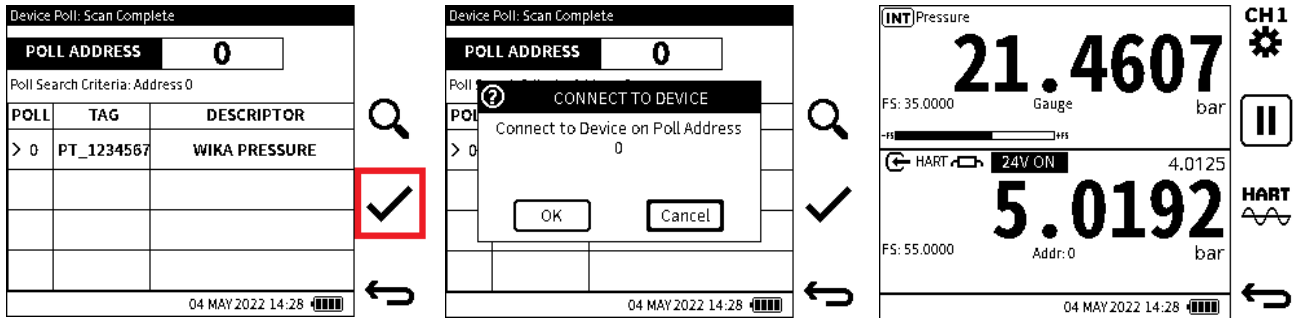

- When the scan is complete or when the scan is immediately stopped, the table will show the **HART** device(s) that have been sensed.

If more than one device is shown, select the wanted device for connection. Tap on the device data or use the Navigation Pad.

Select the **Tick** ✓ Softkey to connect to the selected device.

Select **OK** to connect to the selected device and go back to the **Calibrator** screen. An option is to use the **CANCEL** button to go back to the **Device Poll** setup screen.

The **HART** device is connected, and the Primary reading shows the Primary Variable reading from the **HART** device.

The device Poll Address is shown, together with its full-scale value.

13.3 HART Dashboard

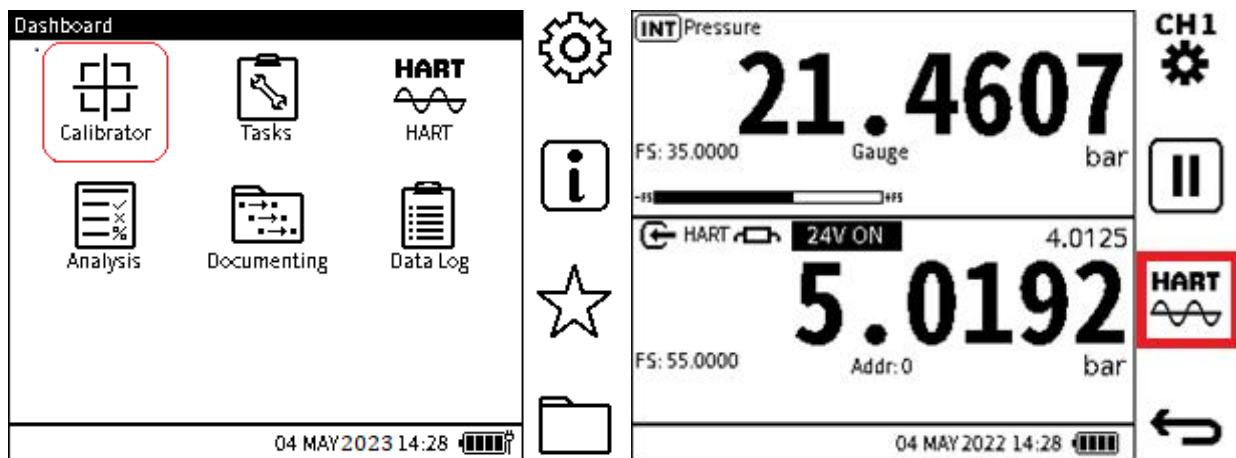

- Select the **Calibrator** icon on the **Dashboard**. The screen will then show the **Calibration** screen: the **HART** icon will replace the **CH2**.

Note: The **HART** device must connect successfully to the DPI610E, for the next screen to show the **HART** Softkey. Refer to the previous section for instructions.

- From the **Calibrator** screen: select the **HART** channel  icon (either tap the screen icon or push the Softkey.)

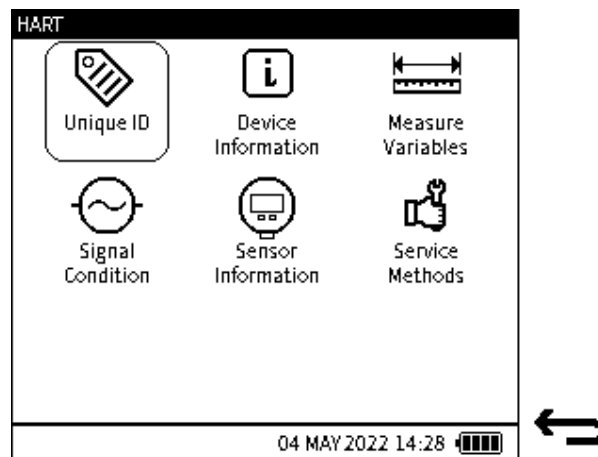

3. The display shows a screen of **HART** options. The next pages show the use of these options.

13.3.1 Unique ID

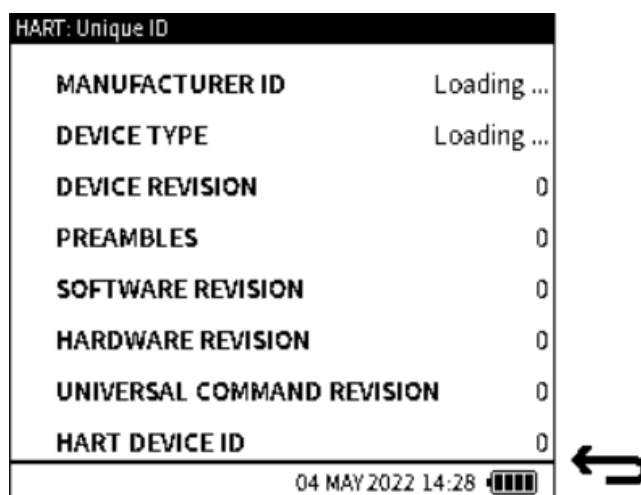

Figure 13-1: Unique ID screen

The **Unique ID** screen gives identity data about the connected **HART** device. This **HART** function gets the long address of the device plus other manufacturer data available and shows it in this screen.

The **PREAMBLES** data relates to the code in a file header: this identifies the start and end of a data packet.

Note: this is a read-only screen.

13.3.2 Device Information



Figure 13-2: Device Information screen

The **HART: Device Information** screen shows data about the device that can be changed. The information options available are shown in the Figure 13-2 above.

To change the device data, select the option and enter the value or text. Select the **Tick ✓** Softkey to make this new change to the device.

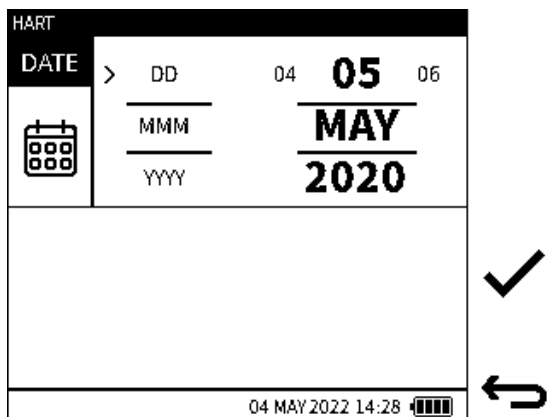
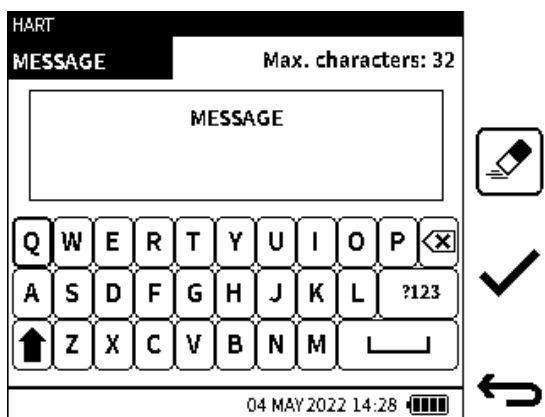
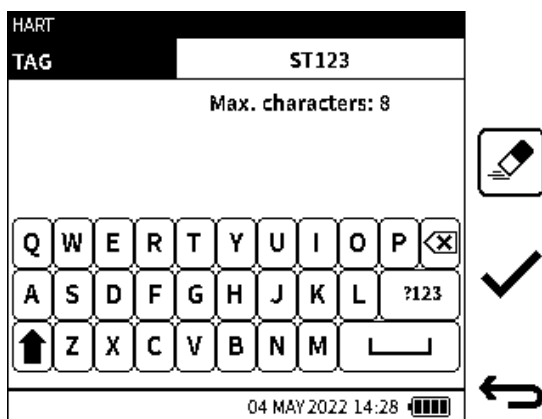

The options include:

- TAG

Chapter 13. HART

- POLL ADDRESS
- DESCRIPTION
- MESSAGE
- DATE
- PREAMBLES

The **PREAMBLES** data relates to the code that identifies the start and end of a data packet.

Note: The Device Information screen options can all be changed, as shown by the small pencil  icon at the end of each option line.

13.3.3 Measure Variables

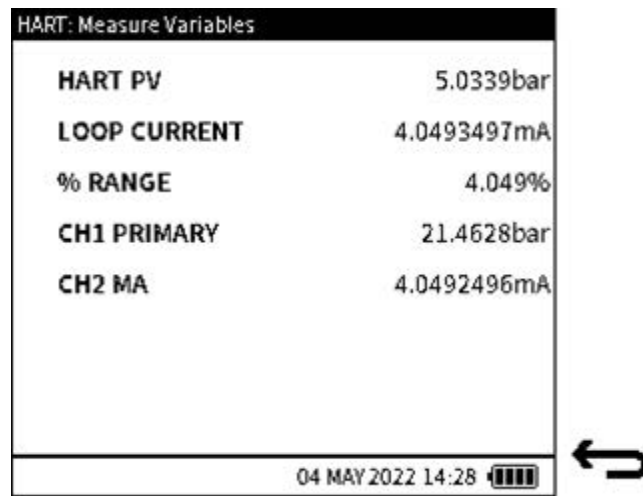

Figure 13-3: Measure Variables screen

This screen shows the following variables:

- **HART PV** - Primary variable
- **Loop Current** - Output by HART device
- **% Range** - Percentage - the real-time PV reading of the PV range
- **CH1 Primary** - Main reading on CH1
- **CH2 MA** - Loop current measured by the DPI610E

13.3.4 Signal Condition

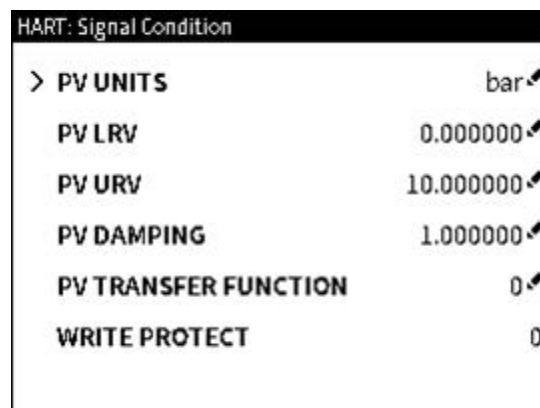

Figure 13-4: Signal Condition screen

This screen shows the following variables:

- **PV Units** - Measurement units of the primary variable
- **PV LRV** - Primary variable Lower Range Value
- **PV URV** - Primary variable Upper Range Value
- **PV Damping** - Primary variable damping value in seconds
- **PV Transfer Function** - Selection code for Primary transfer function
- **Write Protect** - Write protect code

Note: variables with a pen  icon can be changed.

13.3.5 Sensor Information

HART: Sensor Information	
SERIAL NUMBER	5634521
SENSOR UNITS	bar
LRL	0.000000
URL	10.000000
MINIMUM SPAN	0.010000

Figure 13-5: Sensor Information screen

This screen shows the following variables:

- **Serial Number**
- **Sensor Units**
- **LRL (Lower Range Limit)**
- **URL (Upper Range Limit)**
- **Minimum Span**

Note: This is a read-only screen.

13.4 HART Service Methods



Figure 13-6: Service Methods Screen

The Service Methods available on the DPI610E are:

Chapter 13. HART



- **LOOP TEST**
- **D/A OUTPUT TRIM** (see page 223)
- **PRESSURE ZERO TRIM** (see page 226)

13.4.1 LOOP TEST

This method sets the output of the **HART** device to a user-specified analog (current) value. It is useful when a test is done of the integrity of the current loop, to make sure the system operates correctly. The DPI610E Loop test method lets the user force an output current between 4 and 20 mA for the usual transmitter operation. The output current can also be forced between <3.6 mA and >21 mA, to make sure that the failure alarm indication in the device operates correctly and also the A to D Trim. The recorded current output from the HART device is measured by the mA input of the DPI610E calibrator.

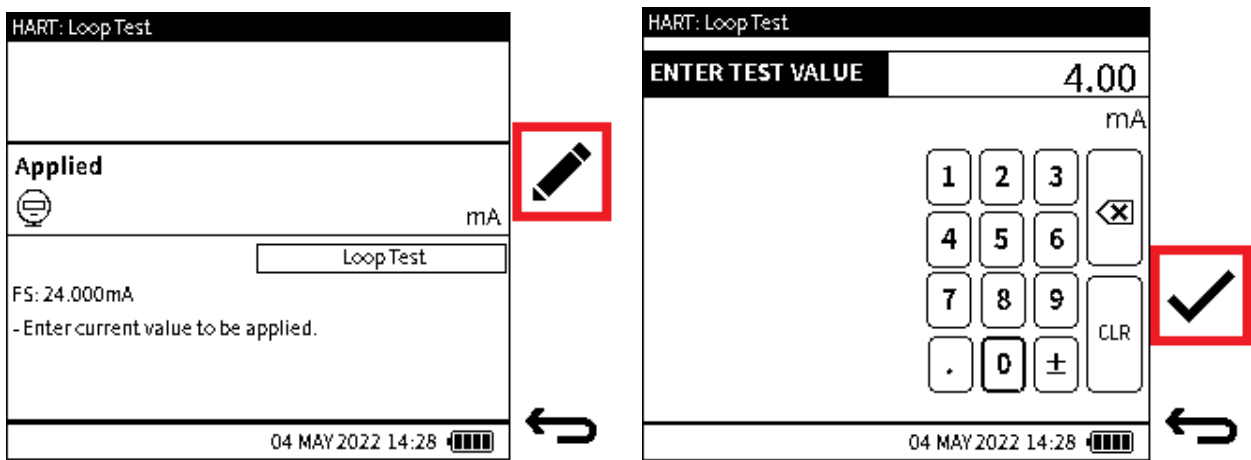

To output a current:

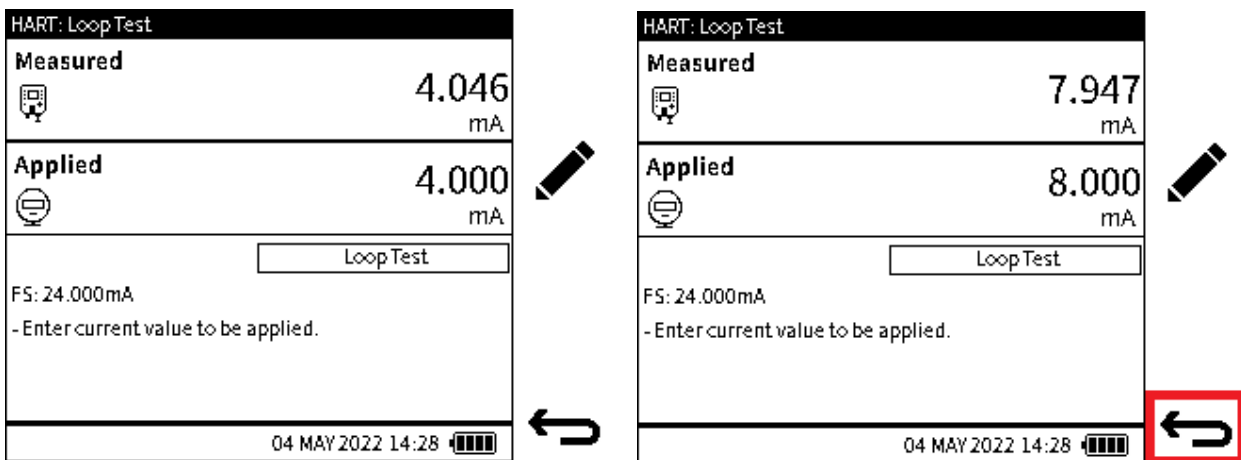

1. Select **LOOP TEST** from the **HART: Service Methods** screen. In the **Loop Test** screen, select the **Edit**  Softkey.
2. Enter the wanted output value and select the **Tick**  Softkey.



3. This screen shows the current measured by the DPI610E as the result of the forced current output from the **HART** device.

Note: The signal measured by the DP610E is shown by the icon , while that measured by the **HART** device is shown by the  icon.

- Do the test again if necessary, with all the wanted current output values and make sure the measured current value is acceptable.

To stop the loop test, select the **Back**  Softkey.

13.4.2 D/A OUTPUT TRIM

The Digital/Analog (D/A) trim will decrease the analog current output for the HART device under test. This is to make the current agree with the mA measured input of the DPI610E calibrator. If necessary, a decrease in value is done at the low value point and/or the high value point: this adjusts the transmitter's digital to analog converter.

To do a D/A trim:

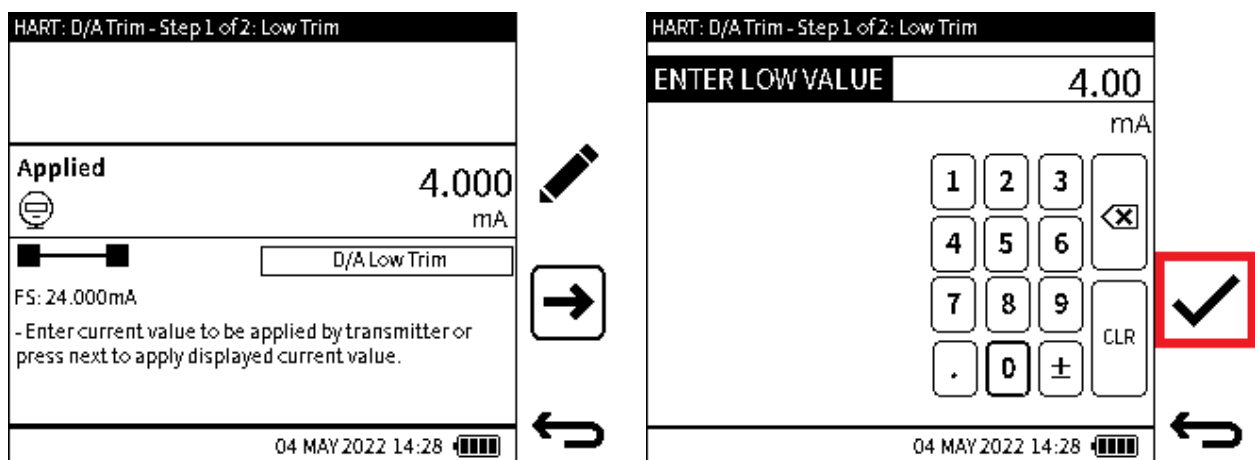

- Select **D/A OUTPUT TRIM** from the **HART: Service Methods** screen (see Figure 13-6 on page 221).

The screen on the left is the first part of the D/A trim procedure. This focuses on the Low (value) adjustment.

The default Low Trim value is 4 mA.



Select the **Edit**  Softkey (Step 2) to change this value if wanted.

If no change is wanted, select the **Next**  Softkey to proceed (Step 3).

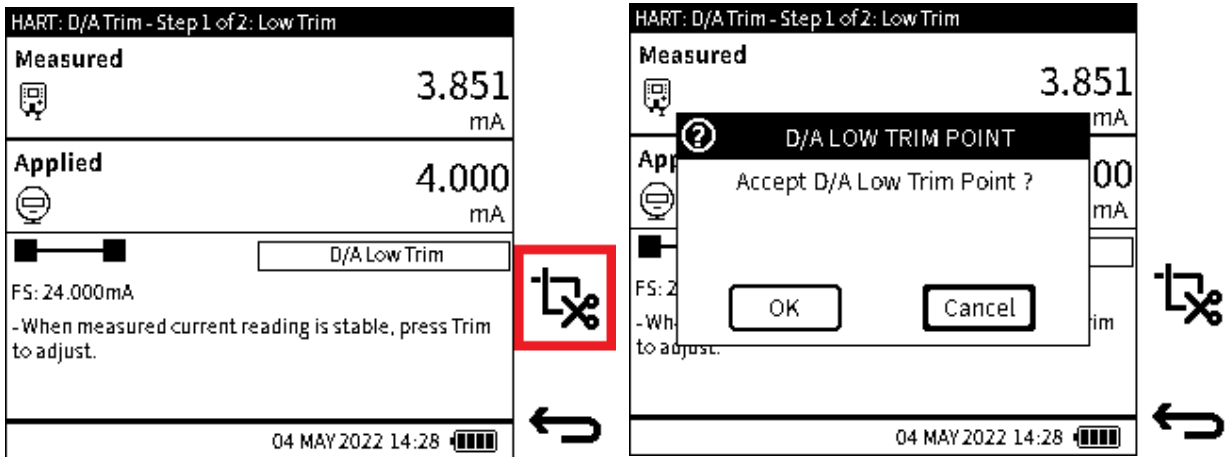
- Enter the wanted Low Trim value and select the **Tick**  Softkey to enter this value.





3. The **Low Trim** value has been applied and the measured value now appears.

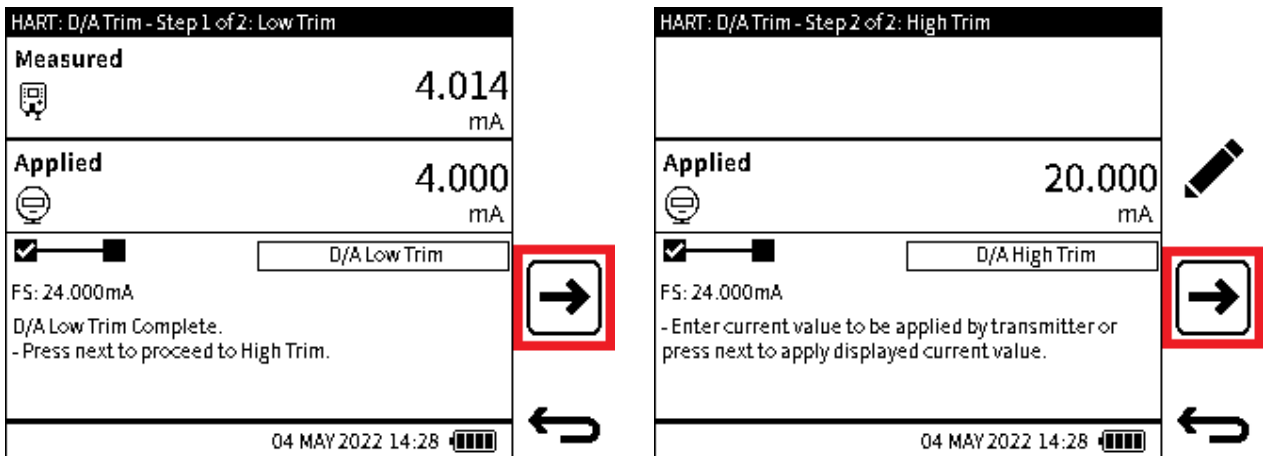

Note: The signal measured by the DPI610E is shown by the icon , while that measured by the HART device is shown by . Make sure that the reading is stable.

To do the trim operation, select the **Trim**  Softkey. Select **OK** in the popup message to accept the Trim. Another option is to select **CANCEL** to go back to the previous step.





4. When the **Low Trim** is complete, select the **Next**  Softkey to go to the **High Trim** procedure or select the **Back**  Softkey to stop.

5. The second part of the D/A trim procedure is for the High (value) trim. The default **High Trim** value is 20 mA.

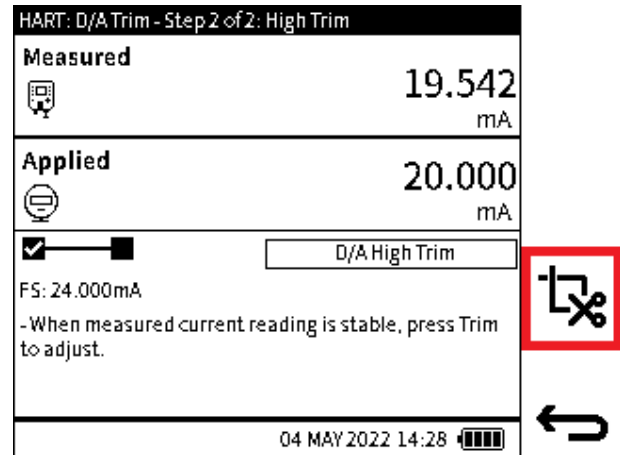
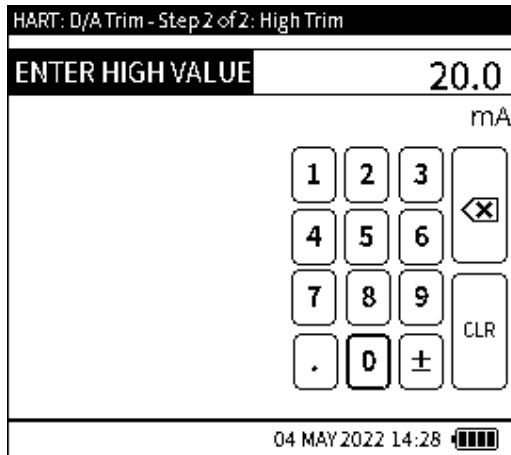
This value can be edited if wanted by the selection of the **Edit**  Softkey (Step 6). If no change is necessary, select the **Next**  Softkey to continue (Step 7).



6. Enter the wanted **High Trim** value and select the **Tick** ✓ Softkey to enter the value.
7. The **High Trim** value has been applied and the screen shows the measured value.

Note: the signal measured by the DPI610E is shown by the icon , while that measured by the HART device is shown by . Make sure that the reading is stable.

To do the trim at this point, select the **Trim**  Softkey.

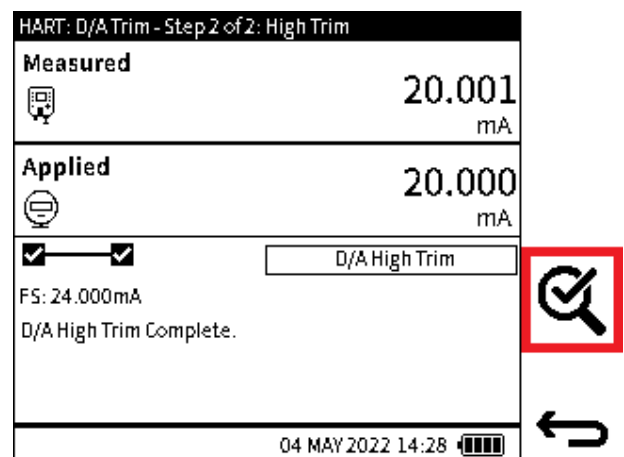
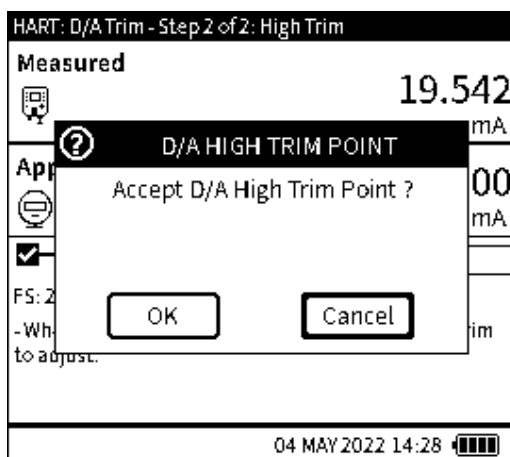

8. Select **OK** in the popup message window to accept the Trim, or select **Cancel** to go back to Step 6.
The **High Trim** is complete. This completes this step of the D/A trim procedure.
The final step of the procedure is to make sure that the D/A trim adjustment is sufficient.
9. Select the **Verification** Softkey to test if the adjustment has been sufficient.

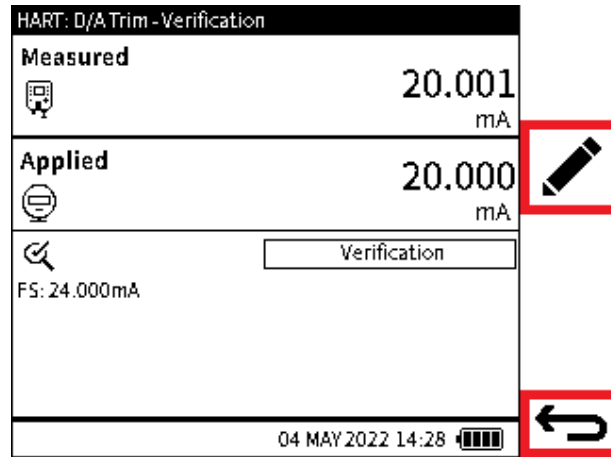

10. In the **Verification** screen, use the **Edit**  Softkey to enter test current output values between 0 and 24 mA and examine the measured values at each point.

To close the Verification screen, use the **Back**  Softkey.

13.4.3 PRESSURE ZERO TRIM

A Zero Trim is a method to cancel out zero-shift that can occur from sensor zero drift or change in installation orientation. It lets the characterization data be adjusted, by the correction of the zero (pressure) value when a “zero” input is applied.

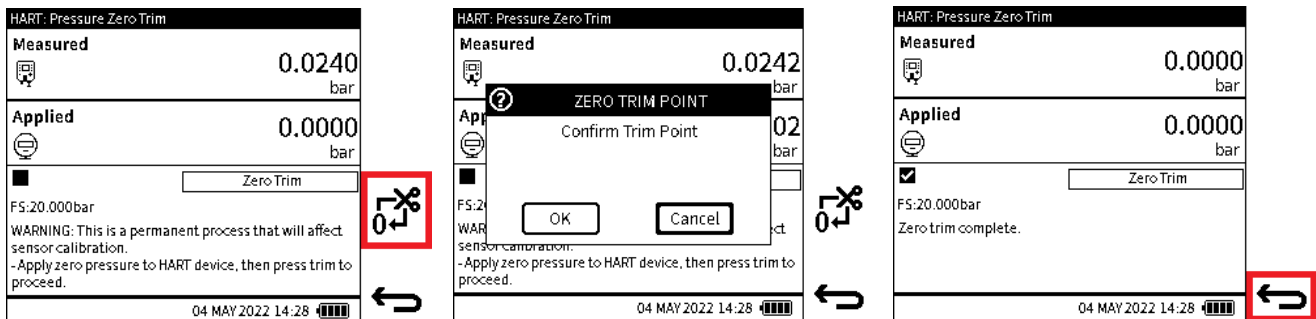

Note: Zero trim must only be used on Gauge or Differential pressure sensors.



1. Select **PRESSURE ZERO TRIM** from the **HART: Service Methods** screen (See Figure 13-6 on page 221).

Make sure the **HART** device correctly connects to the DPI610E.

Use the pump/Volume Adjuster on the instrument or vent the system, to apply 0 pressure. Wait and make sure the reading is stable.

Note: the signal measured by the DPI610E is shown by the icon , and that measured by the HART device is shown by .

Select the **Trim**  Softkey.

2. Select **OK** in the popup message window to accept the Trim, or select **Cancel** to go back to the previous step.

- When the Zero Trim is complete, use the **Back**  Softkey to stop the procedure or do the Trim procedure again if necessary.

13.5 HART Error and Message Codes



Table 13-1: HART Error Codes

Error Code	Description	Error Code	Description
0	Success	23	Sub-device Response Too Long
1	Undefined Error	24-27	Reserved Warning
2	Invalid Selection	28	Multiple Meanings Error
3	Passed Parameter Too Large	32	Device is Busy
4	Passed Parameter Too Large	33	Delayed Response Initiated
5	Too few data bytes received	34	Delayed Response Running
6	Device-specific Command Error	35	Delayed Response Dead
7	In Write Protect Mode	36	Delayed Response Conflict
8-14	Multiple Meaning Warning	37-59	Reserved Error
16	Access Restricted	60	Payload too Long
17	Invalid Device Variable Index	61	No Buffer Available
18	Invalid Unit Code	62	No Alarm/Event Buffers Available
19	Device Variable Index Not Allowed	63	Priority too low
20	Invalid Extended Command Number	64	Command Not Implemented
21	Invalid I/O Card Number	65-72	Multiple Meanings Error
22	Invalid Channel Number	96-111	Reserved Warning

14. Instrument Calibration

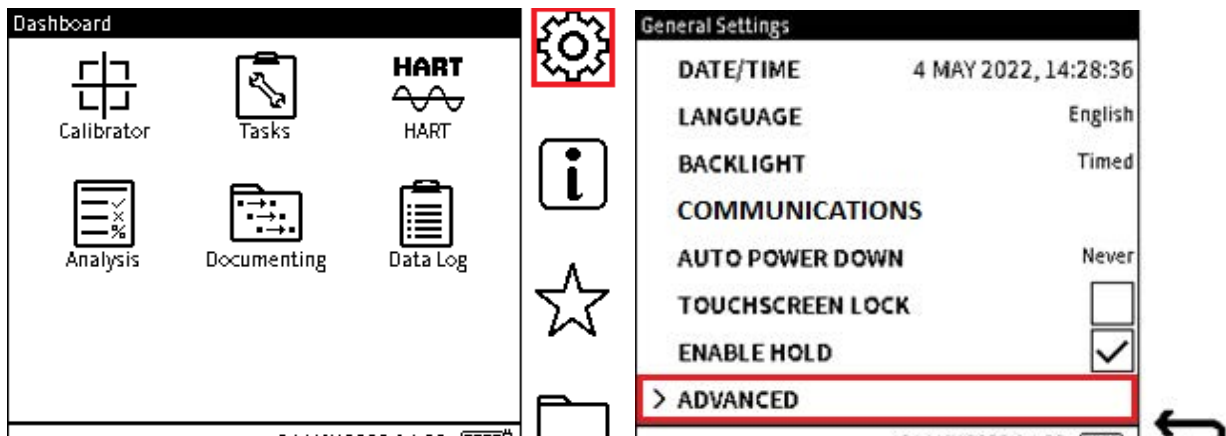
14.1 How to show the Instrument Calibration Screen



1. Select the **Settings** icon  on the Dashboard.
Tap on the icon or push the Softkey on the right of the icon.
2. Select **ADVANCED** at the bottom of the **General Settings** screen.
Tap on **ADVANCED** or use the Navigation Pad to move to bottom row and push the Pad's Enter  key to select.

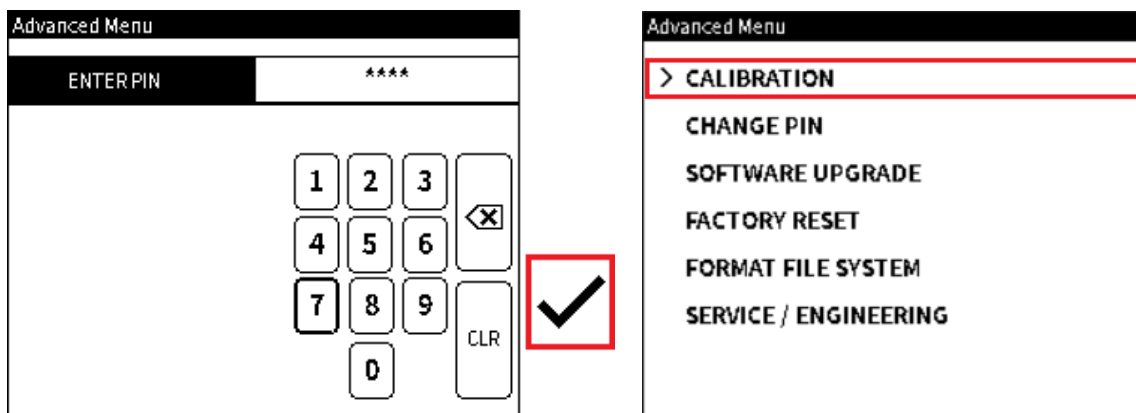

3. Use the on-screen keypad in the **Advanced Menu** screen to enter the PIN number (**4321** is the default value until a custom PIN is selected) and then select the **Tick**  icon.
4. In the **Advanced Menu** screen, select **CALIBRATION**.
Refer to Chapter 5, “Advanced Menu” on page 41, for instructions for how to use the other **Advanced Menu** options.

Chapter 14. Instrument Calibration

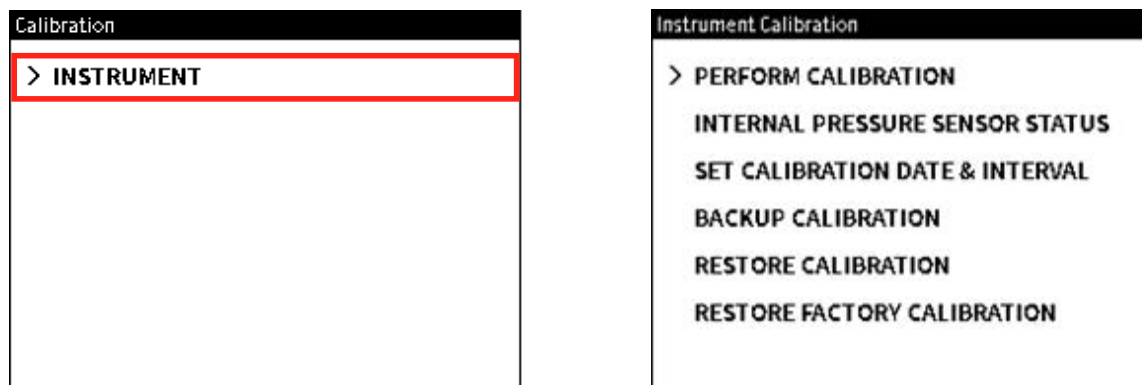

5. Select **INSTRUMENT** in the **Calibration** screen to show the **Instrument Calibration** menu.
6. The different **Instrument Calibration** options become available

14.1.1 The Instrument Calibration screen options

Option	Description
PERFORM CALIBRATION	Calibrate the instrument
INTERNAL PRESSURE SENSOR STATUS	Look at internal pressure sensor details
SET CALIBRATION DATE & INTERVAL	Set instrument date and interval
BACKUP CALIBRATION	Make a copy of the current calibration status
RESTORE CALIBRATION	Apply a previous calibration status to the instrument
RESTORE FACTORY CALIBRATION	Apply the factory (default) calibration status to the instrument

Note: The information in this chapter is for the calibration of Internal and External sensors. To let the DPI610E recognize and use external sensors, refer to Chapter 8, “External Sensors” on page 131.

14.2 HOW TO DO CALIBRATION

The following functions are available in the **Perform Calibration** screen:

Function	Direction	Range
Current	Measure	20 mA
		55 mA
	Source	24 mA
Voltage	Measure	20 V
		30 V
	Source	10 V
Millivolts	Measure	200 mV
		2000 mV
Pressure	Measure	Dependent on sensor fitted
Barometer	Measure	750 to 1150 mbar

Note: To get access to the **Perform Calibration** screen (Figure 14-1), select **PERFORM CALIBRATION** from the **Instrument Calibration** screen.

Note: The **Filter** process option must be **ON** for sensor calibration, see Section 6.4.3 on page 85 for the procedure.

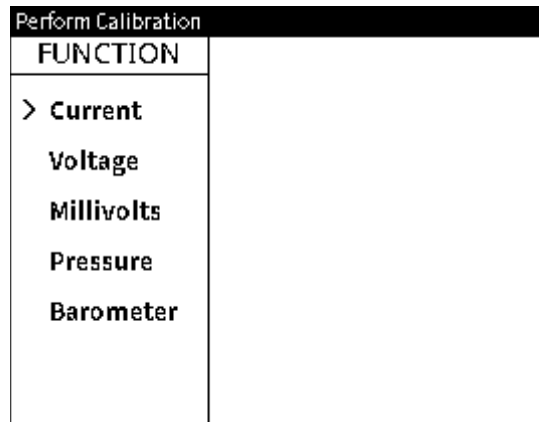
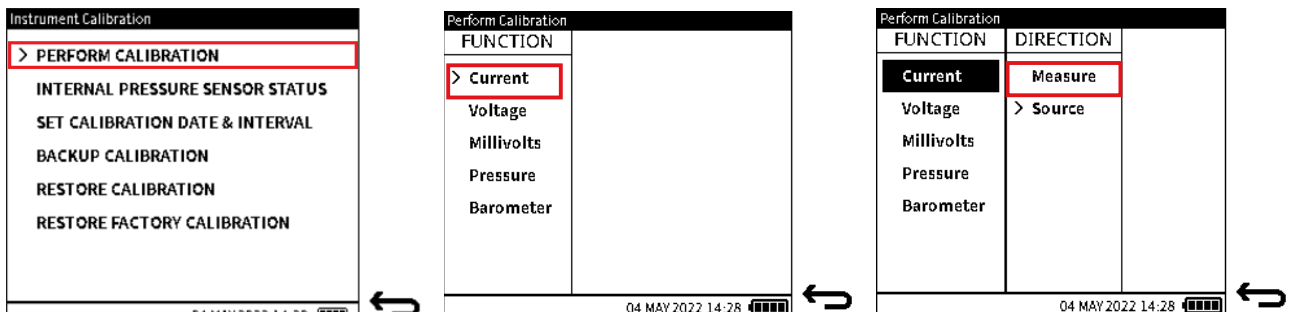

Figure 14-1: Perform Calibration screen

14.2.1 Calibration - Electrical Functions

The procedure to change **Current**, **Voltage** and **Millivolts** options is almost the same for all options. Thus, on the next pages the procedure to change Current variables is the same as for Voltage and Millivolts. The **Pressure** and **Barometer** options use different procedures.

To calibrate an electrical function (Current Measure is used in this example), make sure the electrical connection between the DPI610E and the external calibrated equipment is correct (See Section 6.3.9 on page 65 for Current Measure electrical connection diagram).



1. Select **PERFORM CALIBRATION** from the **Instrument Calibration** menu.
2. Select a **FUNCTION** option (for example, **Current**).
3. Select a **DIRECTION** option if applicable (for example, **Measure**).

Chapter 14. Instrument Calibration

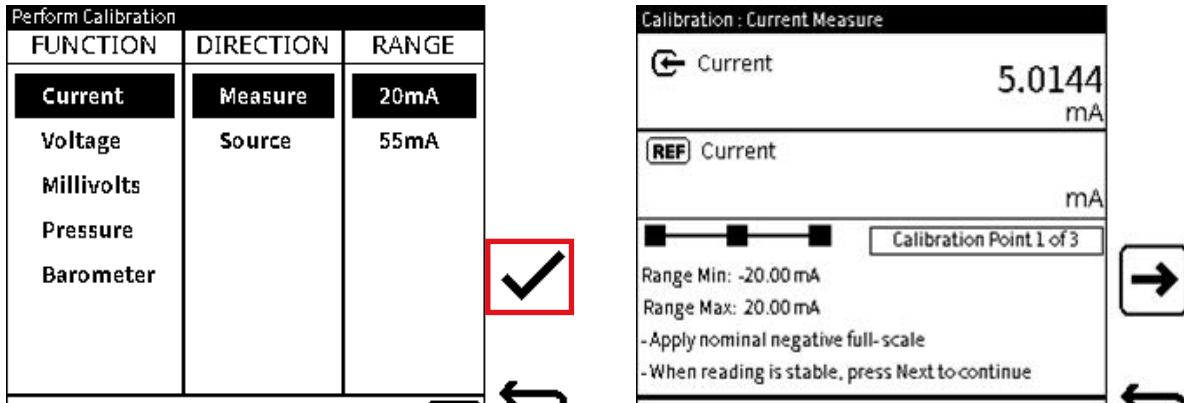

4. Select a **RANGE** option if applicable (for example, 20 mA).

Select ✓ to confirm.

5. The next screen has three areas.

The top two sections give:

- The reference reading from external calibrated equipment.
- The measured (or sourced) reading from the DPI610E.

The bottom section gives the following information:

- Function minimum range (or negative full-scale) value.
- Function maximum range (or positive full-scale) value
- Calibration procedure step status (visual status boxes and text status)
- Instructions for each step of the procedure.

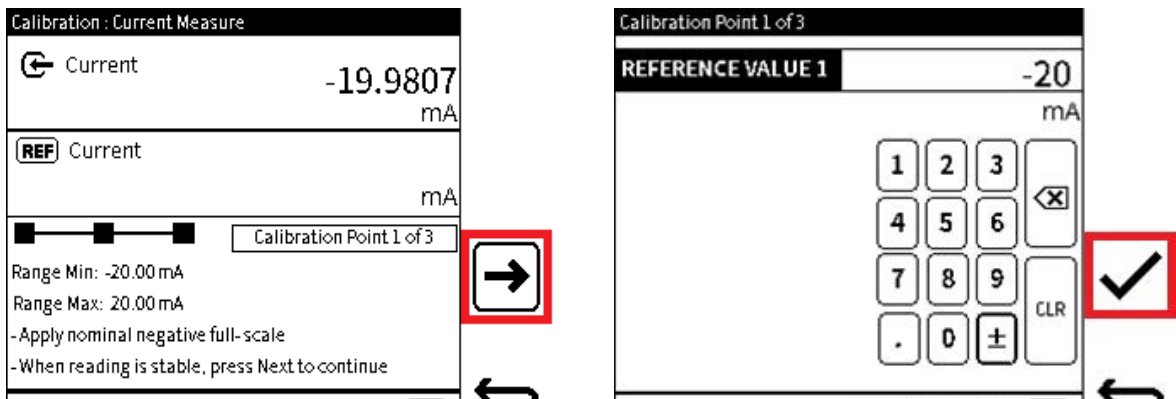

6. The screen will give an instruction to apply a nominal negative full-scale Current (approximately -20 mA) to start the calibration. This is **Calibration point 1**.

When the measured Current reading is stable, select the **Next** → icon to continue.

Note:

- All electrical measure functions must have a 3-point calibration.
- Current Source function must have a 2-point calibration.
- Voltage source function must have a 1-point calibration.

7. Enter the **REFERENCE VALUE 1** value as shown on the external calibrated equipment. Push the **Tick** ✓ Softkey to enter the value and then go back to the **Calibration** screen.

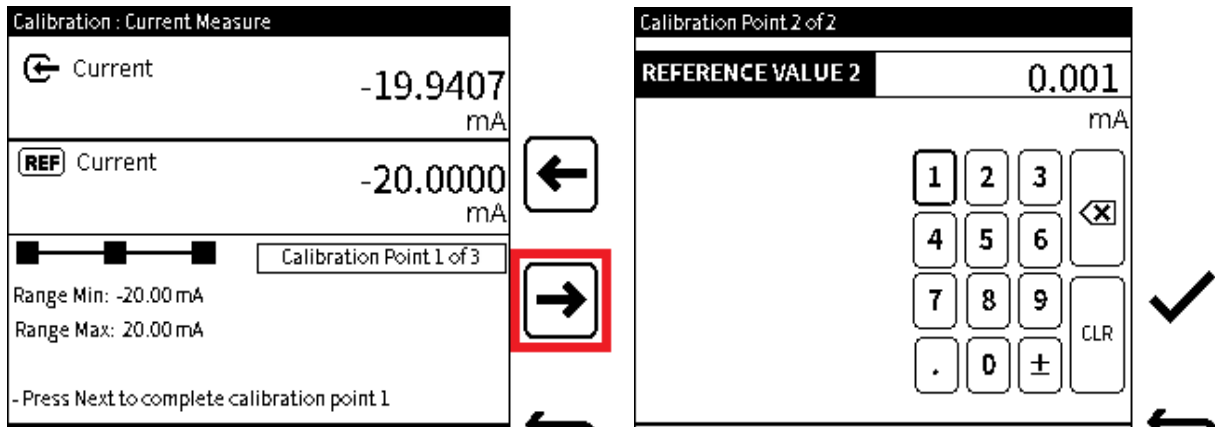

8. Push the **Next** → Softkey to complete **Calibration point 1** and proceed to **Calibration point 2**.
9. Apply Steps 6 to 8, but start by the use of the nominal zero Current (approximately 0 mA) to the DPI610E. This completes Calibration point 2.

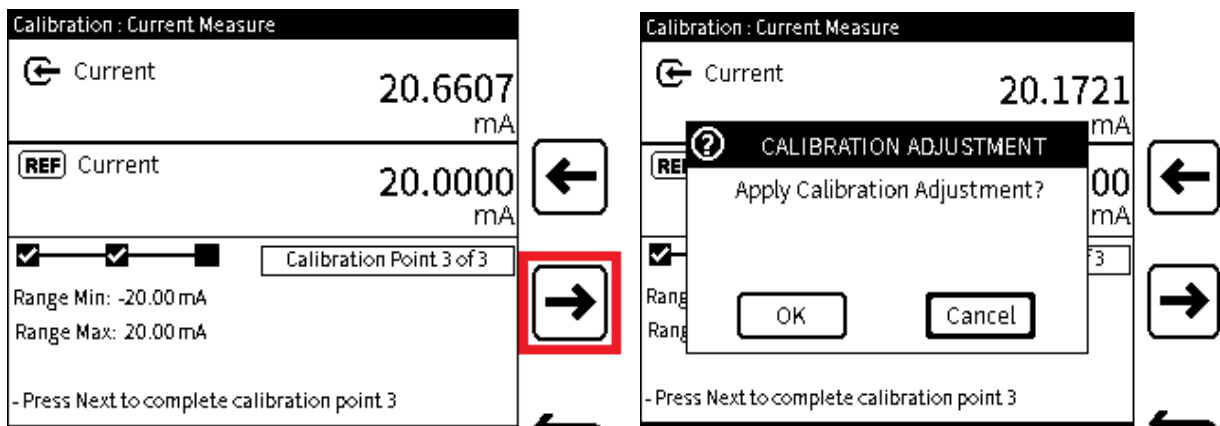

10. Use Steps 6 to 8 again, but start by the application of the positive full-scale Current (approximately 20 mA) to the DPI610E. Push the **Next** → Softkey to complete Calibration point 3.
11. The screen shows a message window for the calibration adjustment to be done. This adjustment uses the same calibration points used in the procedure. Select **OK** to apply the calibration adjustment. If wanted, to stop the procedure, select the **Cancel** button to go back to the **Calibration** screen.

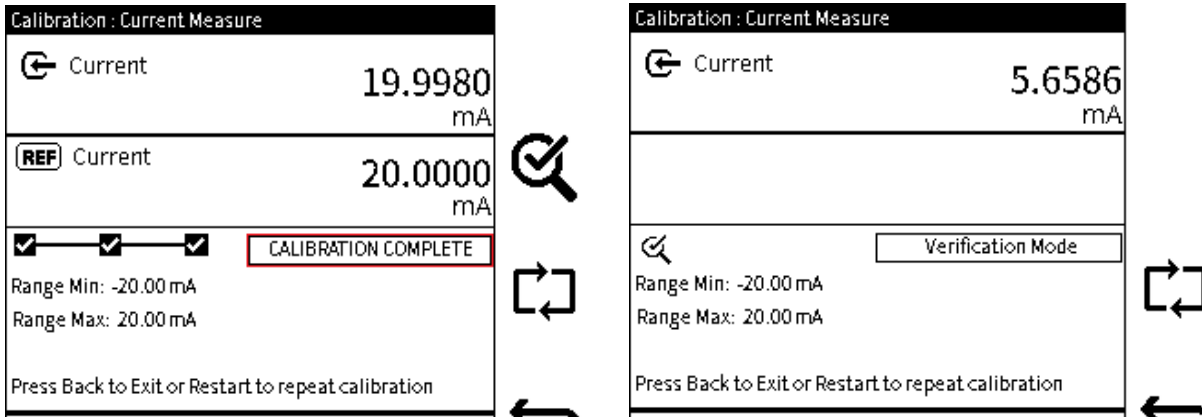

12. If **OK** is selected, the **CALIBRATION COMPLETE** message appears in the status box, to show that the adjustment has been done.

There are three methods available to continue, each with an icon. These are:

VERIFICATION Softkey that shows the Verification screen (see Step 13).

RESTART Softkey that lets the calibration procedure be started again if a new calibration is necessary.

BACK Softkey stops the calibration procedure and go back to the **Perform Calibration** menu screen.

13. The **Verification** mode shows real-time reference and measured (or sourced) values. Here, different values or points in the measured (or sourced) range can be examined to make sure the adjustment is satisfactory.

When verification is complete, select the **Back** icon to stop the calibration procedure. An option is to select the **Restart** Softkey to do the calibration again.

14.2.2 Calibration - Internal Pressure Sensor

To calibrate the internal pressure sensor of the DPI610E, make sure the correct pressure connection is made from the Test Port to the external calibrated pressure source. This sensor calibration must only be done by Service Centers and personnel that have the necessary approval.

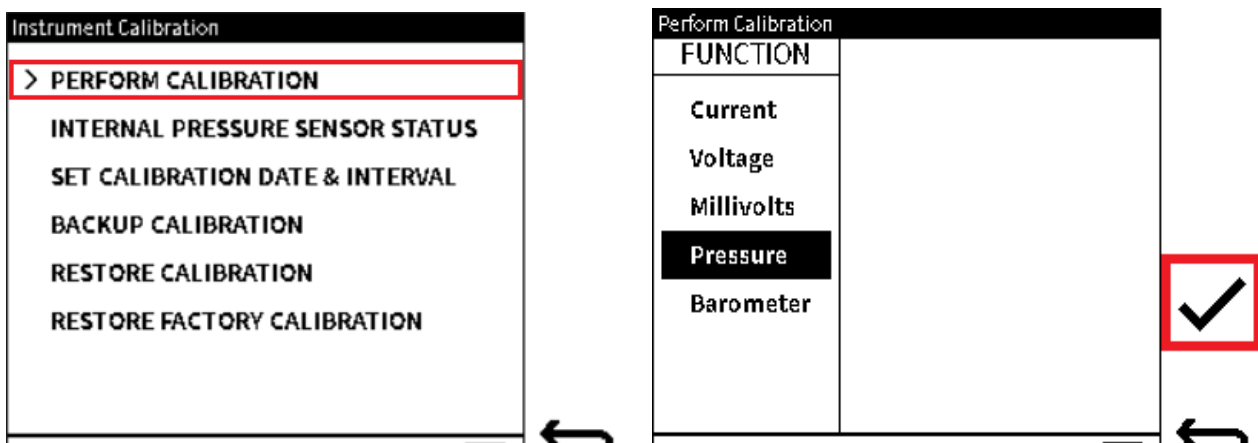

1. Select **PERFORM CALIBRATION** from the **Instrument Calibration** menu.
2. Select **Pressure** function.

Select ✓ to continue.

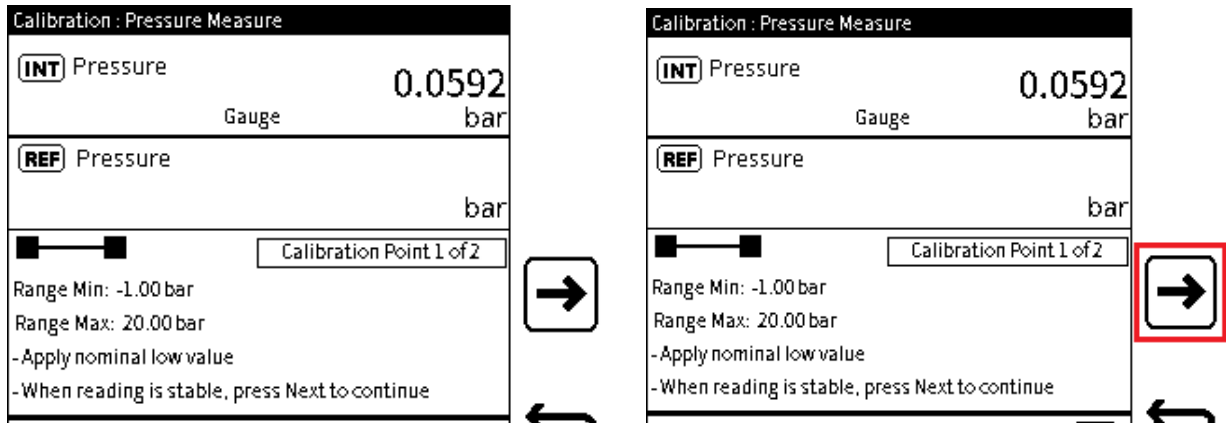

3. This screen has three areas.

The top two sections give:

- The reference reading from external calibrated equipment.
- The measured (or sourced) reading from the DPI610E.

The bottom area gives the following information:

- Function minimum range (or negative full-scale) value.
- Function maximum range (or positive full-scale) value.
- Calibration procedure step status (visual status boxes and text status).
- Instructions for each step of the procedure.

4. To start the calibration, apply nominal negative full-scale or zero pressure as per the shown instruction. This is **Calibration point 1**.

When the measured **Pressure** reading is stable, select the **Next** icon to continue.

Note: Two applicable calibration points are necessary for Pressure sensor calibration.

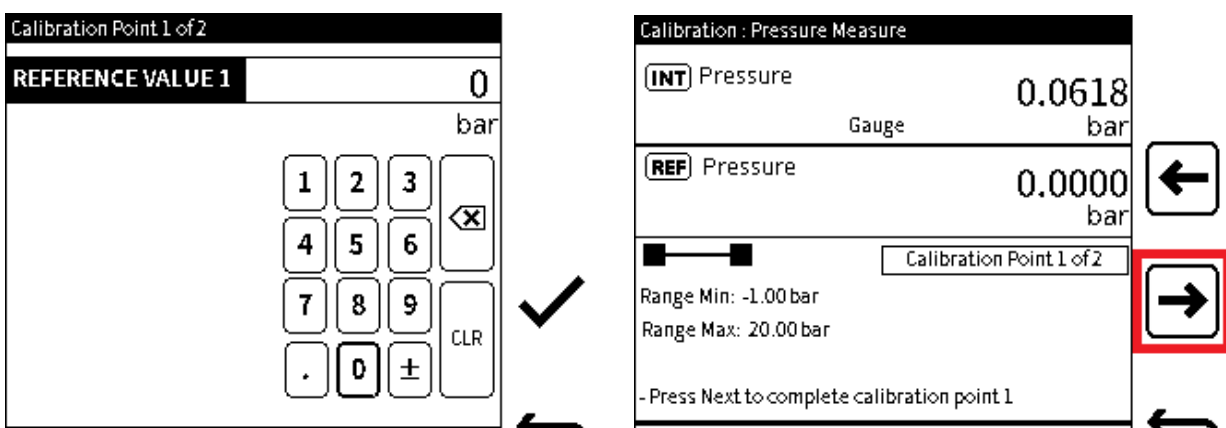

5. Enter **REFERENCE VALUE 1** as shown on the external calibrated equipment. Push the Tick ✓ Softkey to enter the value and go back to the **Calibration** screen.

6. Push the **Next** → Softkey to complete **Calibration point 1** and go to **Calibration point 2**.

Chapter 14. Instrument Calibration

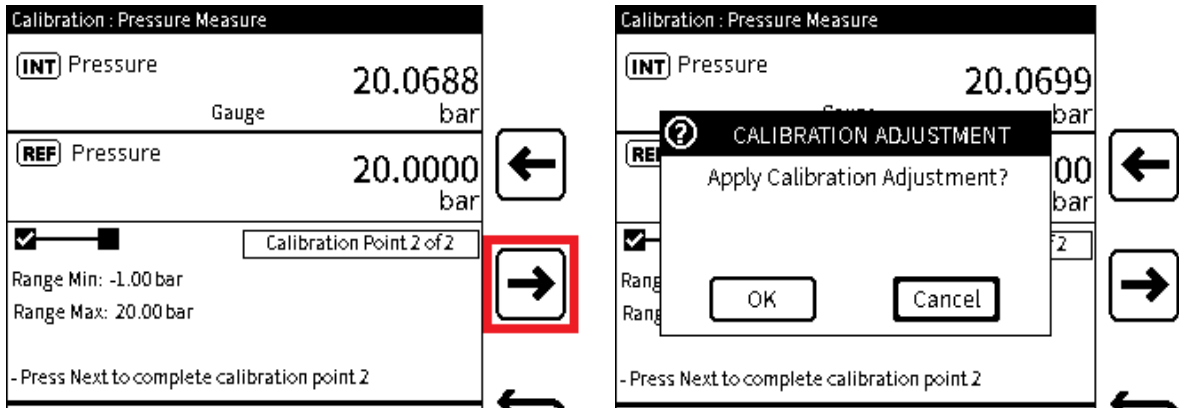

- Apply Steps 4 to 6, but start by the application of the nominal positive full-scale pressure to the DPI610E.

Push the **Next**  Softkey to complete **Calibration point 2** and go to **Calibration point 3**.

- The next screen shows a message window for the calibration adjustment to be done. This adjustment uses the same calibration points used in the procedure.
Select **OK** to apply the calibration adjustment. But, if the procedure is to be stopped, select the **Cancel** button to go back to the **Calibration** screen.

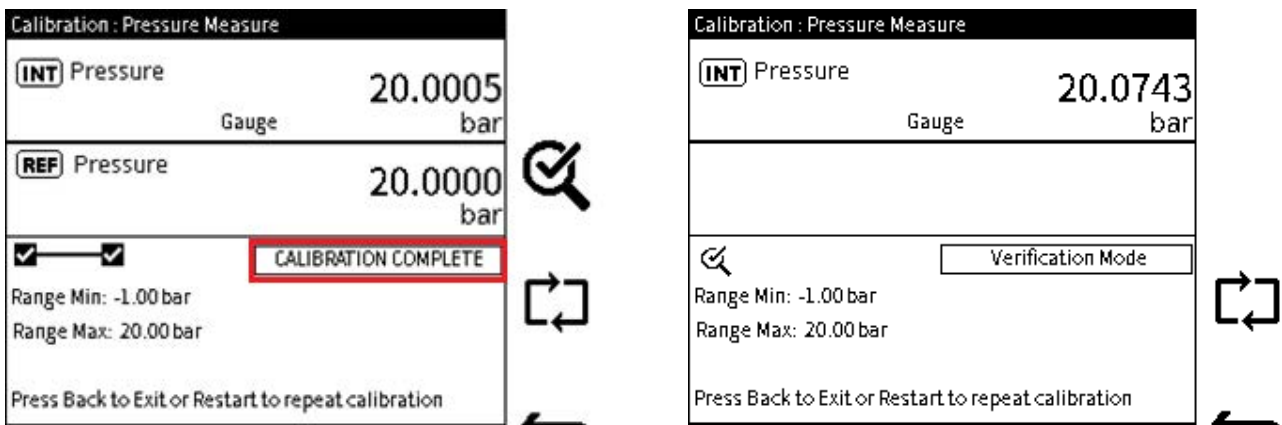

- If **OK** is selected, the **CALIBRATION COMPLETE** message appears in the status box, to show that the adjustment has been done.



There are three methods available to continue, each with an icon. These are:

 **VERIFICATION** Softkey shows the Verification screen (see Step 13).

 **RESTART** Softkey lets the calibration procedure to be done again if a repeat calibration is necessary.

 **BACK** Softkey stops the calibration procedure and then shows the **Perform Calibration** menu screen again.

- The **Verification** mode shows real-time reference and measured (or sourced) values. Here, different values or points in the measured (or sourced) range can be examined to make sure the adjustment is satisfactory.

When verification is complete, select the **Back**  icon to stop the calibration procedure. An option is to select the **Restart**  Softkey to do the calibration again.

14.2.3 Calibration – Internal Barometer

To calibrate the internal barometer sensor of the DPI610, make sure the correct pressure connection is made from the barometer port to the external calibrated pressure source. This sensor calibration must only be done by service centers and personnel that have the necessary approval.

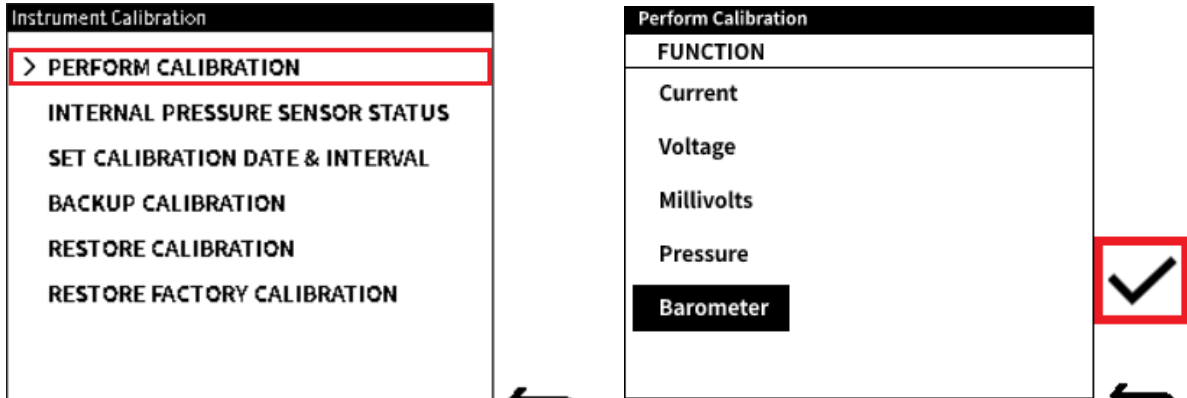

1. Select **PERFORM CALIBRATION** from the **Instrument Calibration** menu.
2. Select **Barometer** function.

Select ✓ to continue.

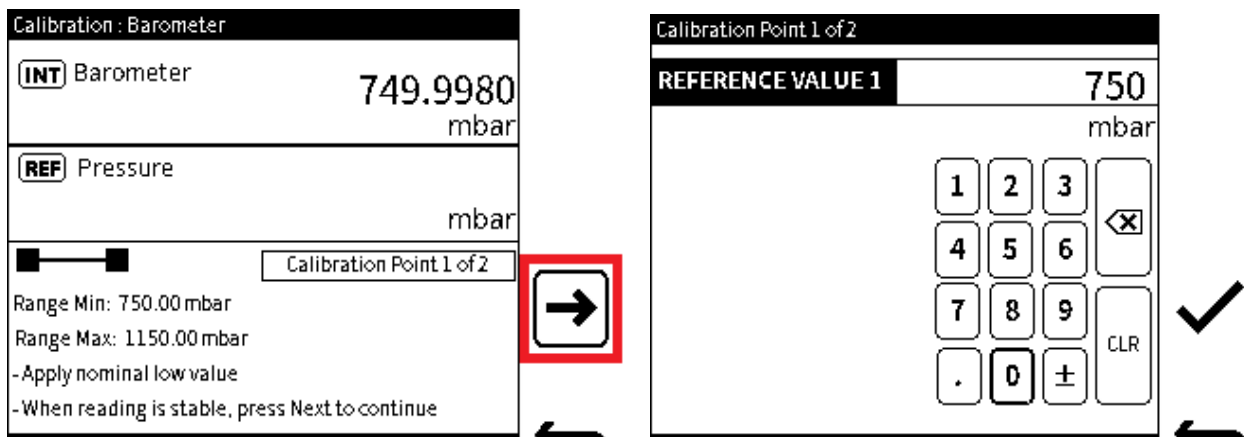

3. The **Calibration - Barometer** screen has three areas.

The top two sections give:

- The reference reading from external calibrated equipment.
- The measured (or sourced) reading from the DPI610E.

The bottom area gives the following information:

- Function minimum range (or negative full-scale) value.
- Function maximum range (or positive full-scale) value.
- Calibration procedure step status (visual status boxes and text status).
- Instructions for each step of the procedure.

To start the calibration, apply nominal negative full-scale or zero pressure as instructed by the screen message. This is **Calibration point 1**.

When the measured Pressure reading is stable, select the **Next** → icon to continue.

Chapter 14. Instrument Calibration

Note: There must be two valid calibration points for the Barometer sensor calibration to occur.

4. Enter **REFERENCE VALUE 1** as shown on the external calibrated equipment. Push the **Tick** ✓ Softkey to enter and then go back to the **Calibration** screen.

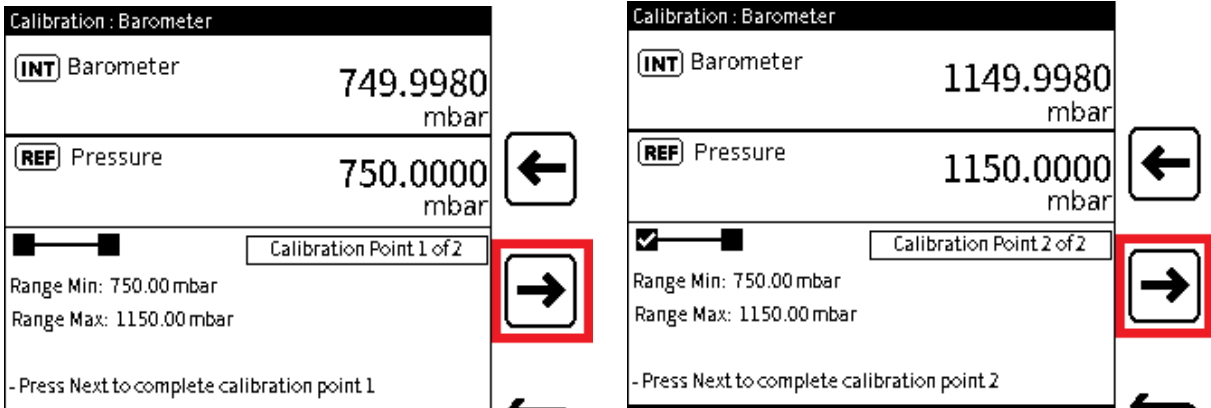

5. Push the **Next** (right arrow) Softkey to complete **Calibration point 1** and continue to **Calibration point 2**.
6. Apply Steps 3 to 5, but start by the application of the nominal positive full-scale pressure to the DPI610E.

When the measured Pressure reading is stable, select the **Next** (right arrow) icon to continue. This completes **Calibration point 2**.

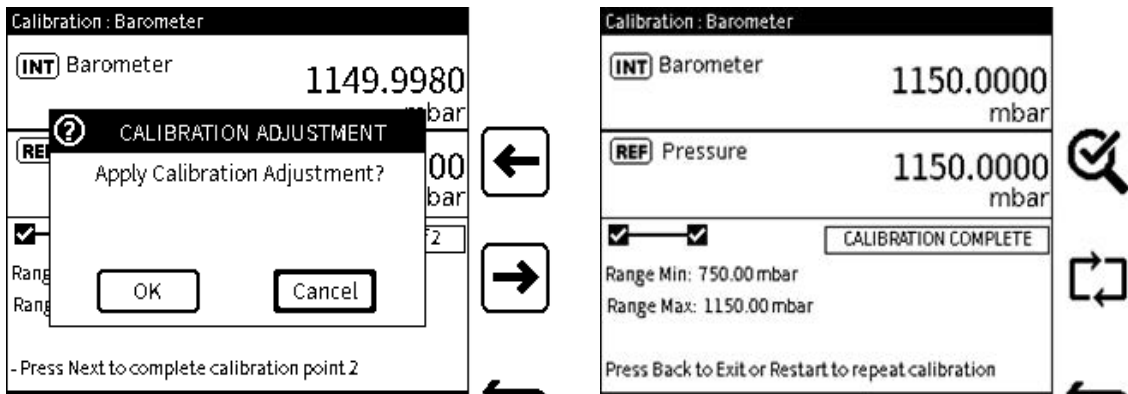

7. After the **Next** (right arrow) icon is selected, the screen shows a message window for the calibration adjustment to be done. This adjustment uses the same calibration points used in the procedure.

Select **OK** to apply the calibration adjustment. But, if the procedure is to be stopped, select the **Cancel** button to go back to the **Calibration** screen.

8. If **OK** is selected, the **CALIBRATION COMPLETE** message will be in the status box, to show that the adjustment has been done.

There are three methods available to continue, each with an icon. These are:

✓ VERIFICATION Softkey shows the Verification screen (see Step 9).

↺ RESTART Softkey lets the calibration procedure to be done again if a repeat calibration is necessary.

INTERNAL PRESSURE SENSOR STATUS

↩ **BACK** Softkey stops the calibration procedure and then shows the **Perform Calibration** menu screen again.

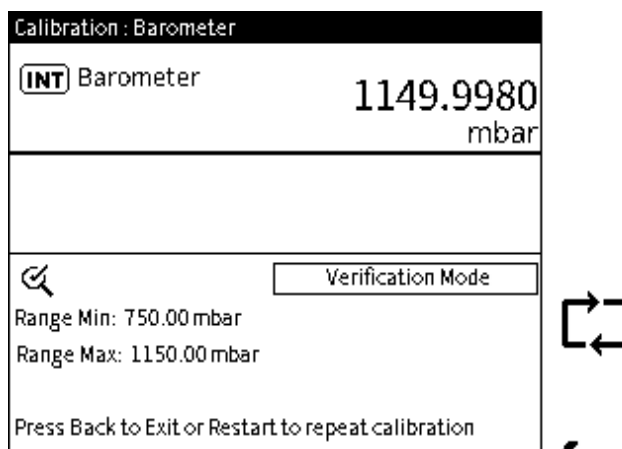

9. The **Verification** mode shows real-time reference and measured (or sourced) values. Here, different values or points in the measured (or sourced) range can be examined, to make sure the adjustment is satisfactory.

When verification is complete, select the **Back** ↩ icon to stop the calibration procedure. An option is to select the **Restart** ↻ Softkey to do the calibration again.

14.3 INTERNAL PRESSURE SENSOR STATUS

The **Internal Pressure Sensor Status** screen (Figure 14-2) gives information about the instrument's internal pressure sensor:

The screenshot shows a screen titled "Internal Pressure Sensor Status". It displays the following information:

SENSOR	DPS500D
SERIAL NUMBER	123456
SENSOR TYPE	Abs
FULL-SCALE	0.000 to 20000.000
UNITS	mbar
LAST CALIBRATION	04 DEC 2021

Figure 14-2: Instrument Status screen

To get access to the **Internal Pressure Sensor Status** screen (Figure 14-2), select **INTERNAL PRESSURE SENSOR STATUS** from the **Instrument Calibration** screen as shown:

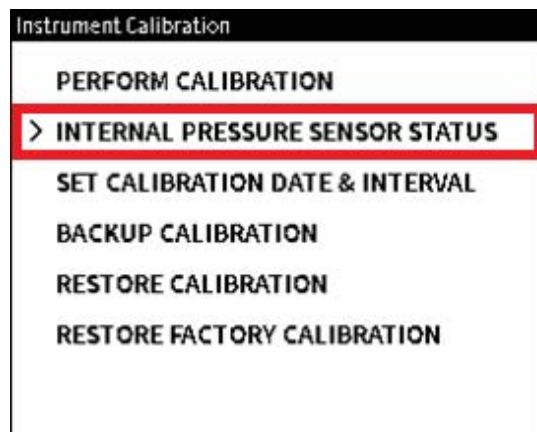

14.4 SET CALIBRATION DATE & INTERVAL

These options are available in the **Instrument Calibration Date & Interval** screen:

Option	Description
LAST CALIBRATION	Set the date of the last calibration of the instrument.
CALIBRATION INTERVAL	Make available user notification. Set the number of days between the last calibration and the next scheduled calibration (default is 365 days).
CALIBRATION DUE	Make available a user notification message. Set a date for the next calibration (default date uses the date of the last calibration and the specified calibration interval).

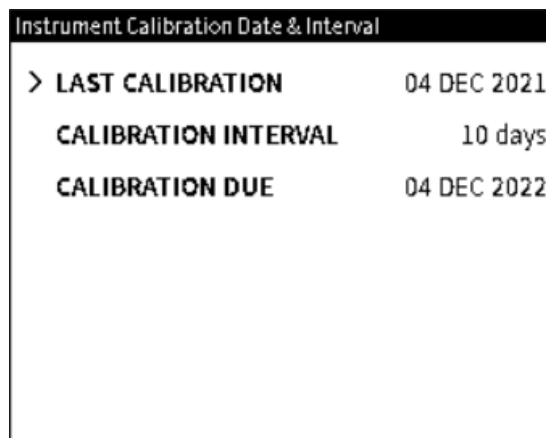
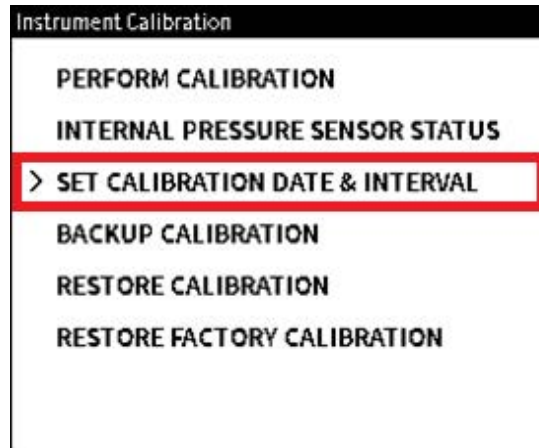
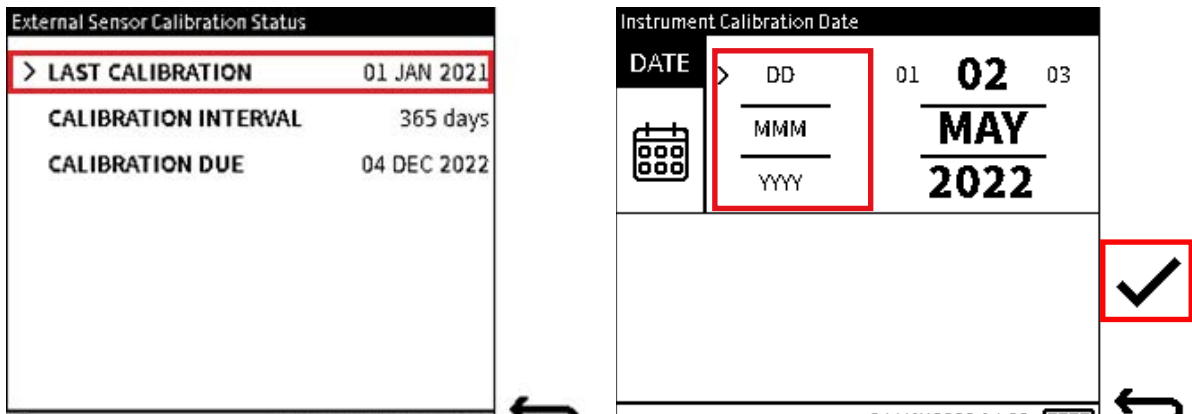

Figure 14-3: Instrument Calibration Date & Interval screen

To get access to the **Instrument Calibration Date & Interval** screen (Figure 14-3), select **SET CALIBRATION DATE & INTERVAL** from the **Instrument Calibration** menu as shown:



14.4.1 How to change the Last Calibration Date



1. Select **LAST CALIBRATION** from the **Instrument Calibration Date & Interval** screen.
2. For the calibration date, select the day, month, and year (see Chapter 1.16.3 on page 16). To change the value, select the row of the variable. Tap the value on the left of the current value to decrease the value and the value on the right to increase the value. Tap either the left or right value again and again to decrease or increase the selected value.

Select ✓ to enter the changes.

14.4.2 How to change the Calibration Interval

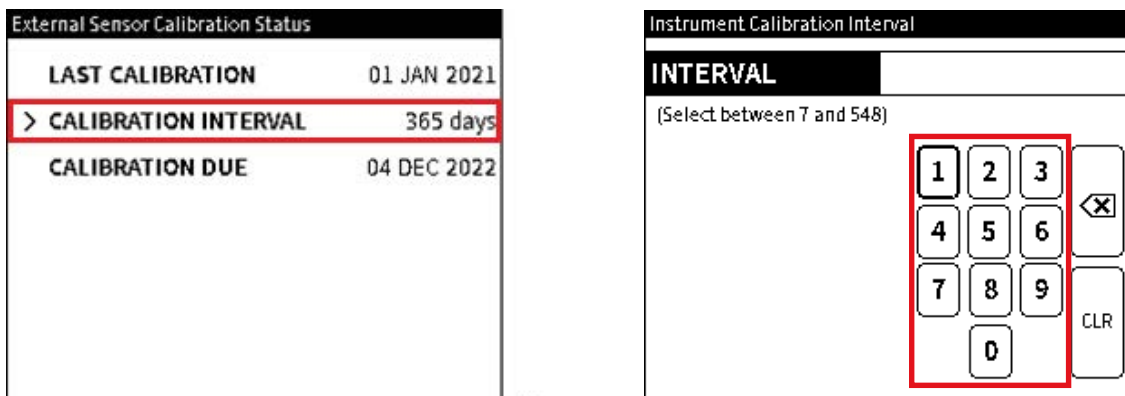

Chapter 14. Instrument Calibration

1. Select **CALIBRATION INTERVAL** from the **Instrument Calibration Date & Interval** screen.
2. Enter a calibration interval between 7 and 548 (days).
Select ✓ to enter the value.

14.4.3 How to change the Calibration Due Date

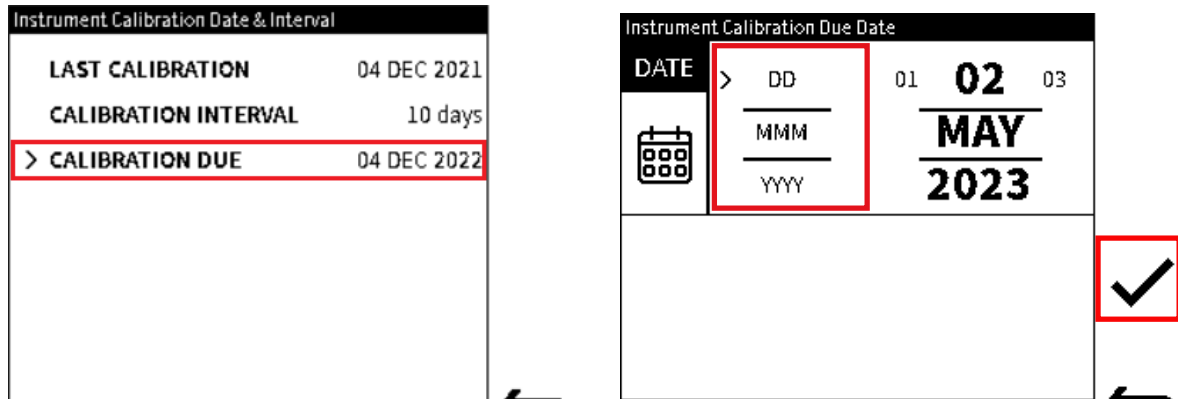

1. Select **CALIBRATION DUE** from the **Instrument Calibration Date & Interval** screen.
2. For the calibration date, select the day, month, and year (see Chapter 1.16.3 on page 16).
To change the value, select the row of the variable. Tap the value on the left of the shown value to decrease the value and the value on the right to increase the value. Tap either the left or right value again and again to decrease or increase the selected value.
Select ✓ to enter the changes.

14.5 BACKUP CALIBRATION

The calibration setup can be saved in the form as a Backup file. If the settings in use become corrupted, it is possible to bring into use the contents of this Backup file.

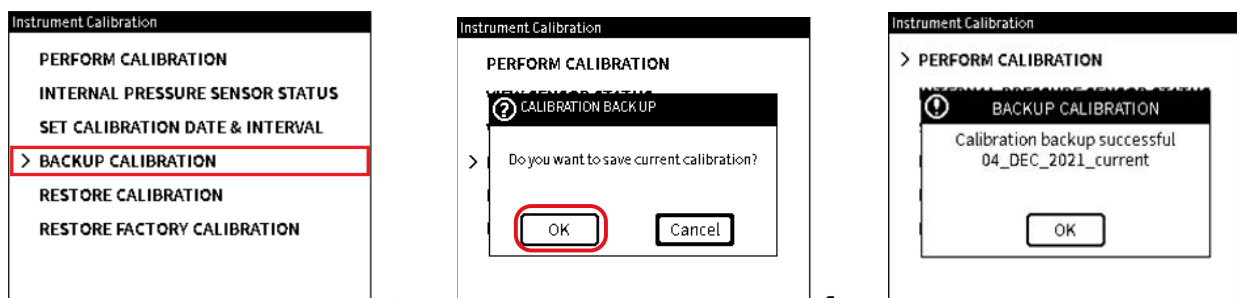

1. Select **BACKUP CALIBRATION** from the **Instrument Calibration Date & Interval** screen.
Note: Only one calibration setup can be saved.
2. Select **OK** to make a backup.
3. Make sure that the screen shows the “**Calibration backup successful**” message. If the screen does not show this message, do steps 1 and 2 again.

14.6 RESTORE CALIBRATION

This function lets the values of a saved calibration setup file replace the calibration settings in use.

Note: To let this calibration restore function to be used, an applicable calibration backup file must be available. See Section 14.5 on page 242 for how to make this file.

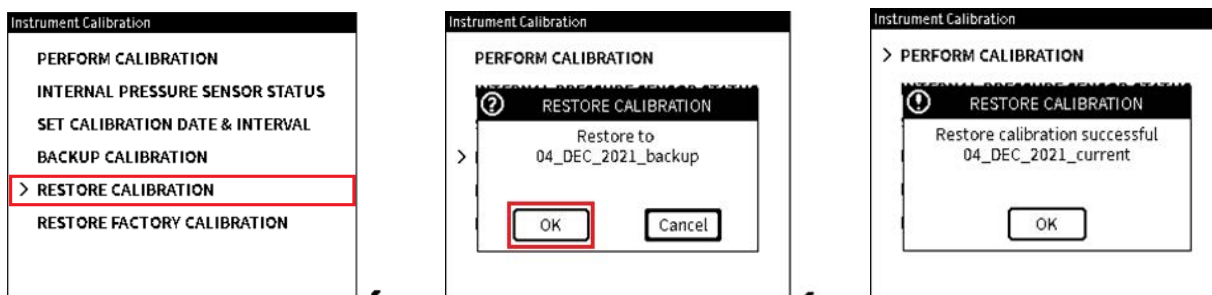

1. Select **RESTORE CALIBRATION** from the **Instrument Calibration** screen.
2. Select **OK** to use the contents of the Restore backup file.
3. Make sure that the screen shows the **CALIBRATION RESTORE** successful message. If the screen does not show this message, do steps 1 and 2 again.

14.7 RESTORE FACTORY CALIBRATION

The instrument has its factory calibration values saved internally before it is delivered. If necessary, these values can be used to put the instrument into a usable condition again. Use the **Restore Factory Calibration** function to do this.

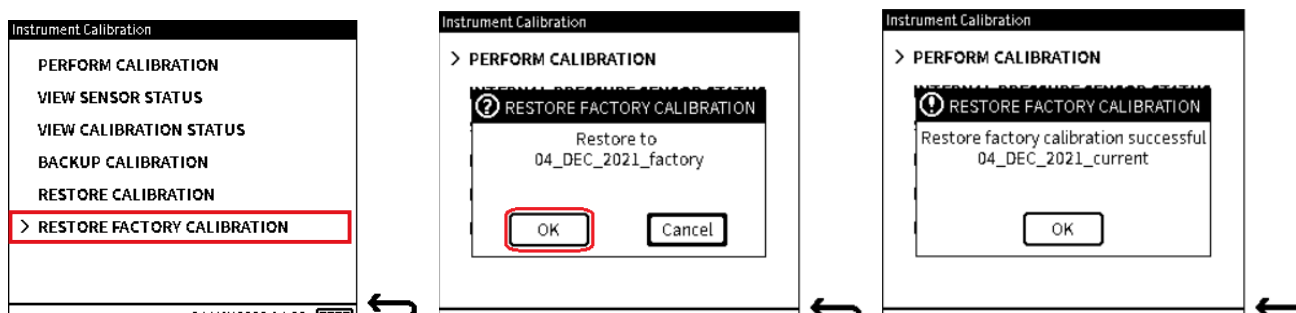

1. Select **RESTORE FACTORY CALIBRATION** from the **Instrument Calibration** screen.
2. The instrument will automatically use the contents of this factory calibration file to replace the settings in use. A popup window will show the name of this backup factory file.
Select **OK** to bring the instrument to its factory condition.
3. Make sure that the screen shows the **FACTORY CALIBRATION RESTORE** successful message.

14.8 EXTERNAL PRESSURE SENSOR CALIBRATION MENU

See Section 14.1 on page 229 for how to get access to the **Calibration** menu from the Dashboard.

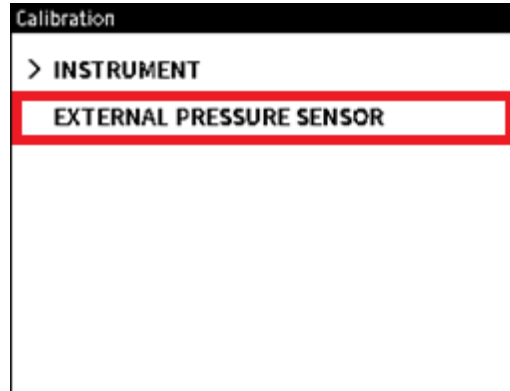

Select **EXTERNAL PRESSURE SENSOR** from the primary **Calibration** screen.

Note: To see the **External Pressure Sensor** option, the **EXT** Pressure function must be already configured in the **Calibrator** menu and the sensor connected successfully. See Section 9, “External Sensors,” on page 131.

14.8.1 PERFORM CALIBRATION

When the DPI610E calibrates the external pressure sensor PM700E, make sure the correct pressure connection is made from the sensor to the external calibrated pressure source. Make sure the supplied sensor cable is used to connect the sensor to the **EXT SENSOR** port on the DPI610E. This sensor calibration must only be done by Service Centers and personnel that have the necessary approval.

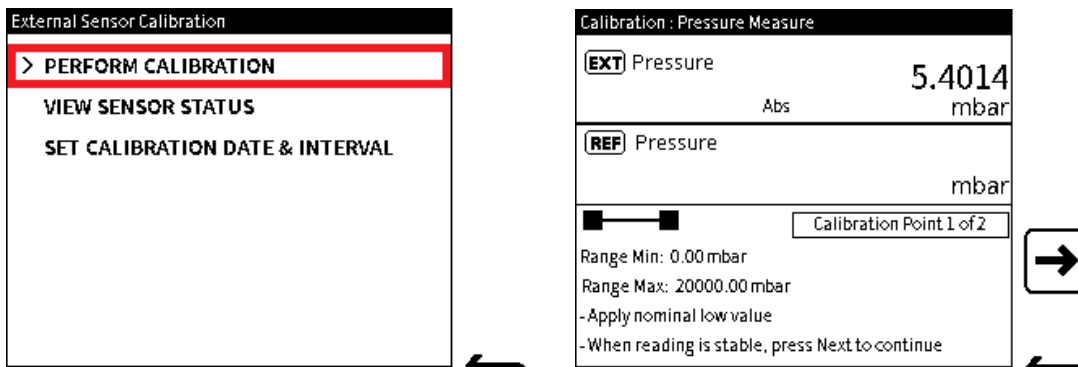

1. Select **PERFORM CALIBRATION** from the **External Sensor Calibration** menu screen.
2. The calibration procedure of the external PM700E sensor is like that of the DPI610 internal pressure sensor. See Section 14.2.2, “Calibration - Internal Pressure Sensor,” on page 234.

EXTERNAL PRESSURE SENSOR CALIBRATION MENU

14.8.2 VIEW EXTERNAL PRESSURE SENSOR STATUS

The **External Pressure Sensor Status** screen (Figure 14-4) gives data about the instrument's external pressure sensor.

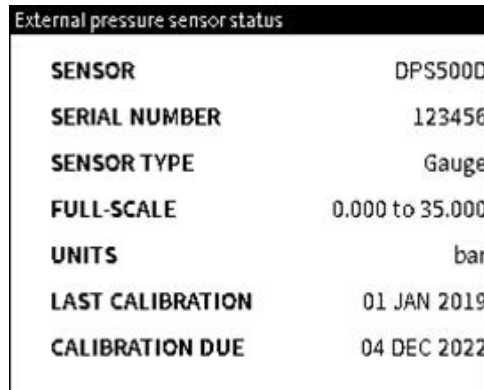

External pressure sensor status	
SENSOR	DPS500D
SERIAL NUMBER	123456
SENSOR TYPE	Gauge
FULL-SCALE	0.000 to 35.000
UNITS	bar
LAST CALIBRATION	01 JAN 2019
CALIBRATION DUE	04 DEC 2022

Figure 14-4: External Pressure Sensor Status

To get access to the **External Pressure Sensor Status** screen, select **VIEW SENSOR STATUS** from the **External Sensor Calibration** screen as shown:

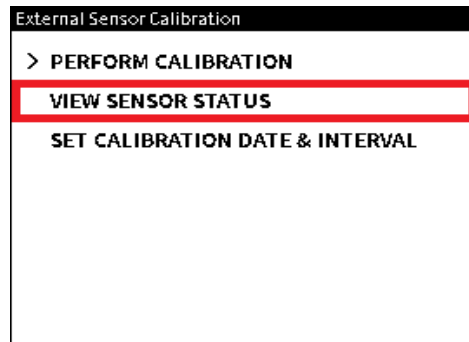

External Sensor Calibration	
>	PERFORM CALIBRATION
	VIEW SENSOR STATUS
	SET CALIBRATION DATE & INTERVAL

14.8.3 SET CALIBRATION DATE & INTERVAL

The **External (Pressure) Sensor Calibration Status (Date & Interval)** screen has these options:

Option	Description
LAST CALIBRATION	Set the date the instrument was last calibrated
CALIBRATION INTERVAL	Make user notification available. Set the number of days between the last calibration and the next scheduled calibration (default is 365 days)
CALIBRATION DUE	Make the user notification available. Set a date for the next calibration. The date that is automatically used, is calculated by the use of the last calibration date and the specified calibration interval.

External Sensor Calibration Status	
LAST CALIBRATION	01 JAN 2021
> CALIBRATION INTERVAL	365 days
CALIBRATION DUE	04 DEC 2022

Figure 14-5: External Sensor Calibration Date & Interval Screen

To get access to the **SET CALIBRATION DATE & INTERVAL** screen, select **SET CALIBRATION DATE & INTERVAL** screen from the **External Sensor Calibration** screen as shown:

External Sensor Calibration	
PERFORM CALIBRATION	
VIEW SENSOR STATUS	
> SET CALIBRATION DATE & INTERVAL	

14.8.3.1 How to Change the LAST CALIBRATION Date

External Sensor Calibration Status	
> LAST CALIBRATION	04 MAY 2022
CALIBRATION INTERVAL	202 days
CALIBRATION DUE	04 DEC 2022

Date of Calibration	
DATE	> DD 31 01 02
	MMM JAN
	YYYY 2021



1. Select **LAST CALIBRATION** from the **External Sensor Calibration Status** screen.
2. For the calibration date, select the day, month, and year (see Section 1.16.3, “Set Date, Time and Language,” on page 16).

To change the value, select the row of the variable. Tap the value on the left of the shown value to decrease the value and the value on the right to increase the value. Tap either the left or right value again and again to decrease or increase the selected value.

EXTERNAL RTD SENSOR CALIBRATION MENU

Select ✓ to enter the changes.

14.8.3.2 How to change the CALIBRATION INTERVAL

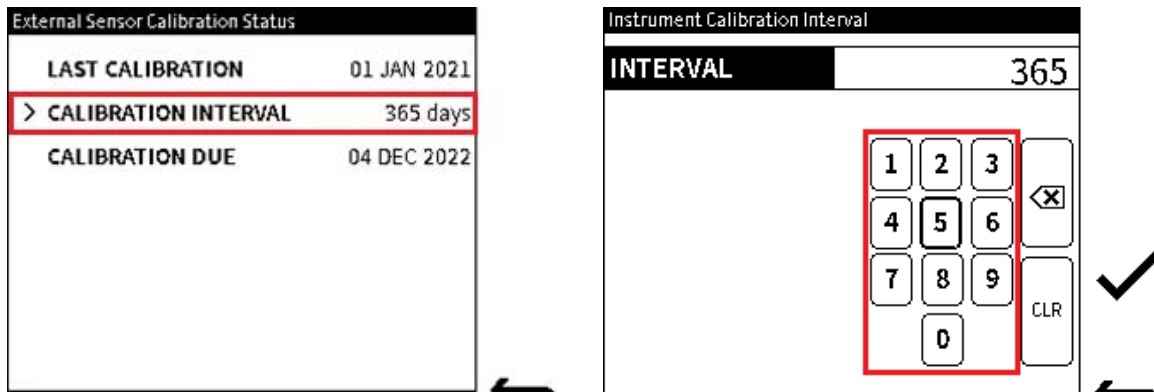

1. Select **CALIBRATION INTERVAL** from the **External Pressure Sensor Status** screen.
2. Enter a calibration interval between 7 and 548 (days).

Select ✓ to enter the value.

14.8.3.3 How to change the CALIBRATION DUE Date

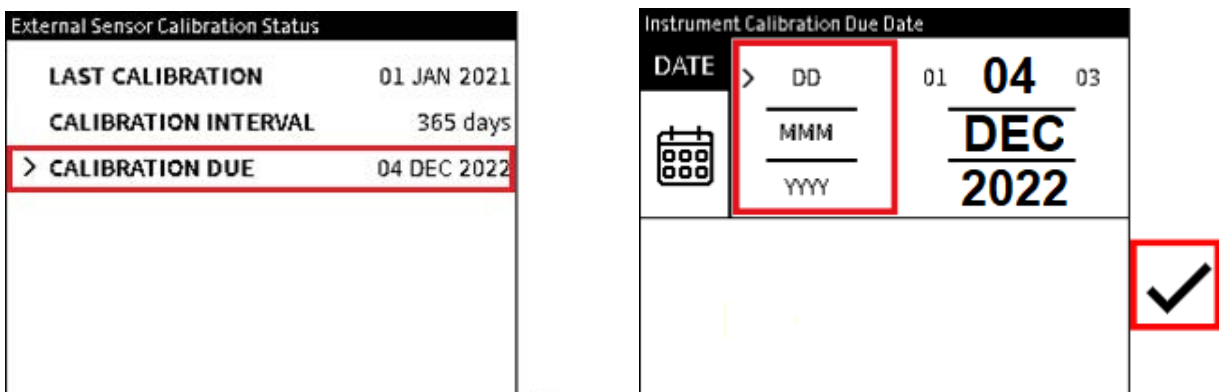

1. Select **CALIBRATION DUE** from the **Instrument Calibration Date & Interval** screen.
2. For the calibration date, select the day, month, and year (see Section 1.16.3, "Set Date, Time and Language," on page 16).

To change the value, select the row of the variable. Tap the value on the left of the shown value to decrease the value and the value on the right to increase the value. Tap either the left or right value again and again to decrease or increase the selected value.

Select ✓ to enter the changes.

14.9 EXTERNAL RTD SENSOR CALIBRATION MENU

Refer to Section 9 on page 131 for how to set the DPI610E to recognize and use an external RTD sensor. This is necessary to make the DPI610E user interface show the calibration options for the RTD sensor.

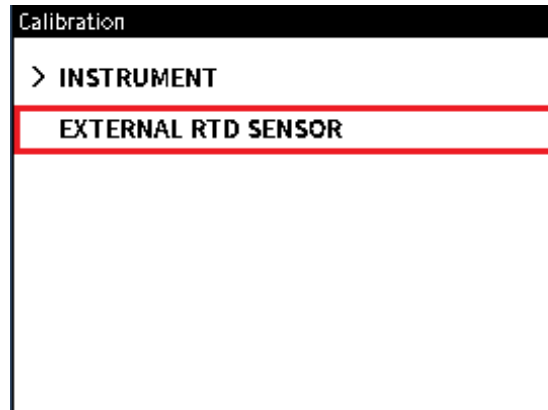

Select **EXTERNAL RTD SENSOR** from the primary **Calibration** menu.

Note: To see the **External RTD Sensor** option, the RTD function must be already set in the Calibrator menu and the sensor connected successfully. Use the cross-reference given at the top of this page for instructions.

14.9.1 HOW TO DO CALIBRATION

When the DPI610E calibrates an external pressure sensor, make sure the correct connection is made between the RTD & RTD-Interface and the external calibrated resistance/temperature source. Make sure the supplied sensor cable is used to connect the RTD-Interface to the **EXT SENSOR** port on the DPI610E. This sensor calibration must only be done by service centers and personnel that have the necessary approval. Use the instructions in Section 9 on page 131 for the calibration procedure.

To get access to the **External Sensor Calibration (RTD)** screen, use this procedure:

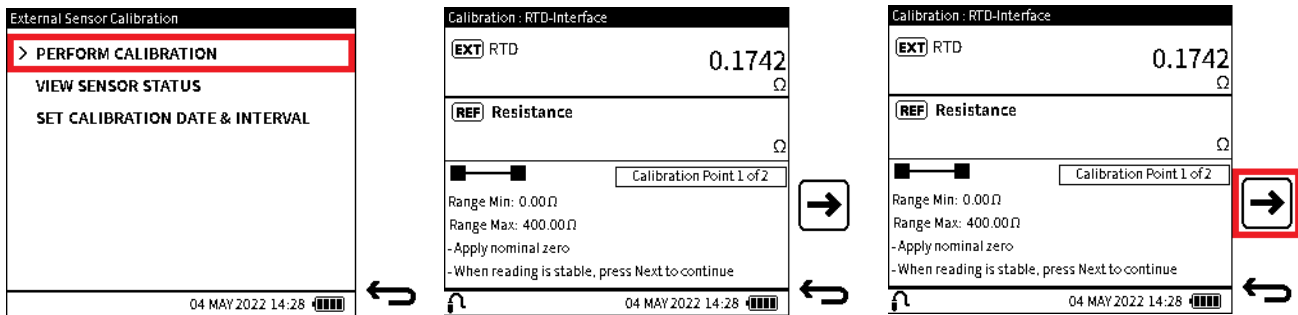

1. Select **PERFORM CALIBRATION** from the **External Sensor Calibration** screen.

The next screen has three areas. The top two areas give:

 - The reference reading from external calibrated equipment.
 - The measured (or sourced) reading from the DPI610E.

The bottom area gives the following information:



 - Function minimum range (or negative full-scale) value.
 - Function maximum range (or positive full-scale) value.
 - Calibration procedure step status (visual status boxes and text status).
 - User instructions for each step of the procedure.
2. A screen message will give an instruction to start the calibration. Apply nominal negative full-scale or zero pressure. This is **Calibration point 1**.

EXTERNAL RTD SENSOR CALIBRATION MENU

When the measured temperature or resistance reading is stable, select the **Next**  icon to continue.

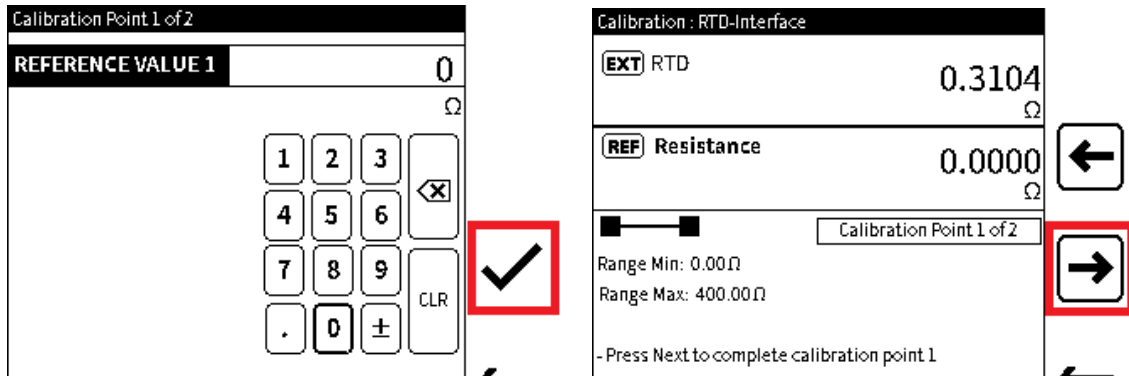
Note: It is necessary that two applicable calibration points be used for RTD sensor calibration.



3. Enter the **REFERENCE VALUE 1** as shown on the external calibrated equipment. Push the **Tick**  Softkey to enter the value and go back to the **Calibration** screen.
4. Push the **Next**  Softkey to complete **Calibration Point 1** and go to **Calibration Point 2**.

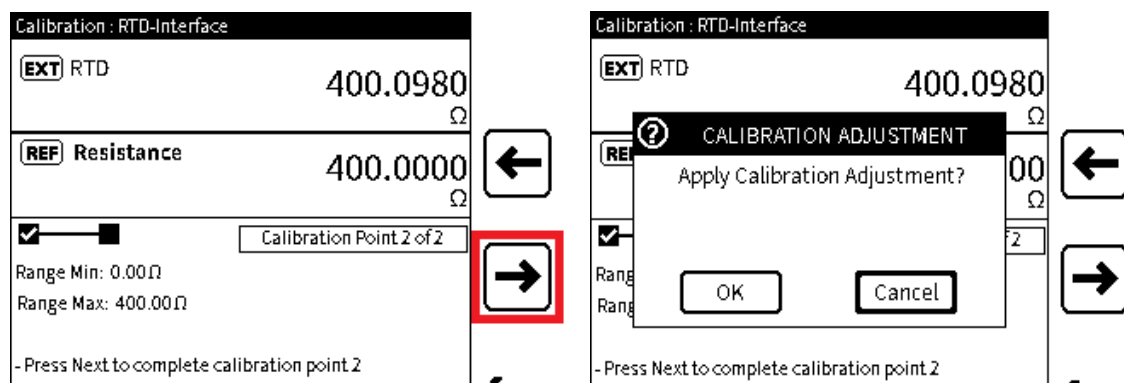

5. Apply the nominal positive full-scale resistance or temperature value to the DPI610E and then do Steps 2 to 4 again. This completes **Calibration Point 2**.

Push the **Next**  Softkey to show the next screen.

6. After the **Next**  icon is selected, the screen shows a message window for the calibration adjustment to be done. This adjustment uses the same calibration points used in the procedure.

Select **OK** to do the calibration adjustment. If the procedure is to be stopped, select the **Cancel** button to go back to the **Calibration** screen.

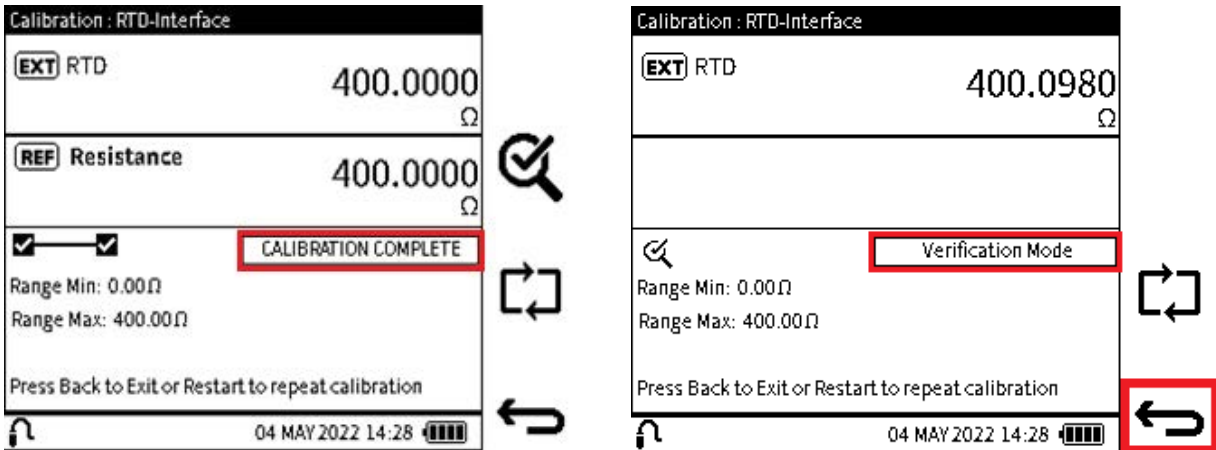

7. If **OK** is selected, the screen shows the **CALIBRATION COMPLETE** message in the status box when the adjustment has been done.

There are three available methods to continue, each has an icon. These are:

VERIFICATION Softkey goes to the **Verification** screen (see Step 8).

RESTART Softkey lets the calibration procedure to be used again if another calibration is necessary.

BACK Softkey closes the calibration procedure and goes back to the **Perform Calibration** menu screen.

8. The verification mode shows real-time reference and measured (or sourced) values.

Here, different values or points in the measured (or sourced) range can be examined, to make sure that the adjustment is satisfactory.

When verification is complete, select the **Back** icon to close the calibration procedure.

Select the **Restart** Softkey to do the calibration again if necessary.

14.9.2 SET CALIBRATION DATE & INTERVAL

The **External (RTD) Sensor Calibration Status** screen has these options:

Option	Description
LAST CALIBRATION	Set the date the instrument was last calibrated.
CALIBRATION INTERVAL	Make available user notification messages. Set the number of days between the last calibration and the next scheduled calibration (default is 365 days).
CALIBRATION DUE	Make available user notification message. Set a date for the next calibration (default date uses the date of the last calibration plus the specified calibration interval). This is Read Only - this variable cannot be changed on this screen.

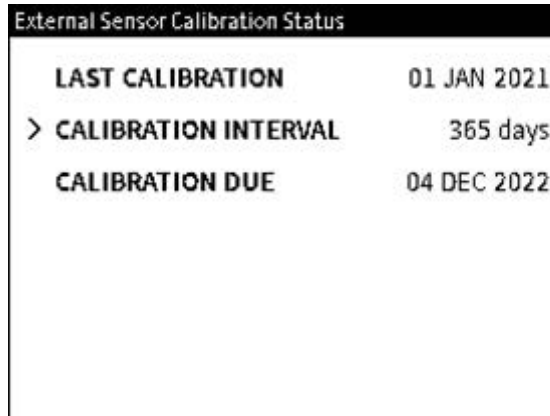

External Sensor Calibration Status

LAST CALIBRATION	01 JAN 2021
> CALIBRATION INTERVAL	365 days
CALIBRATION DUE	04 DEC 2022

Figure 14-6: External Sensor Calibration (Date & Interval) Status Screen

To get access to the **External RTD Calibration Date & Interval** screen, select **SET CALIBRATION DATE & INTERVAL** from the **External Sensor Calibration** screen as shown.

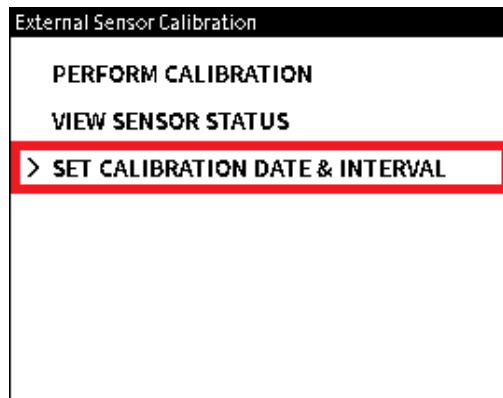

External Sensor Calibration

PERFORM CALIBRATION
VIEW SENSOR STATUS
> SET CALIBRATION DATE & INTERVAL

14.9.2.1 How to Change the Last Calibration Date

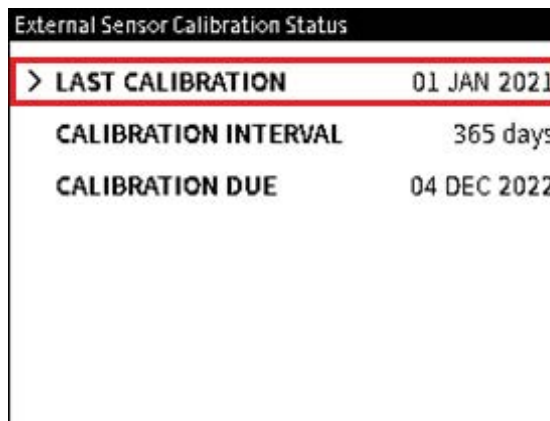

External Sensor Calibration Status

> LAST CALIBRATION	01 JAN 2021
CALIBRATION INTERVAL	365 days
CALIBRATION DUE	04 DEC 2022

1. Select **LAST CALIBRATION** from the **Instrument Calibration Date & Interval** screen.
2. Select the day, month, and year (see Section 1.16.3 on page 16).
To change the value, select the row of the variable. Tap the value on the left of the current value to decrease the value and the value on the right to increase the value. Tap either the left or right value again and again to decrease or increase the selected value.

Select ✓ to confirm the changes.

Chapter 14. Instrument Calibration

14.9.2.2 How to Change the Calibration Interval

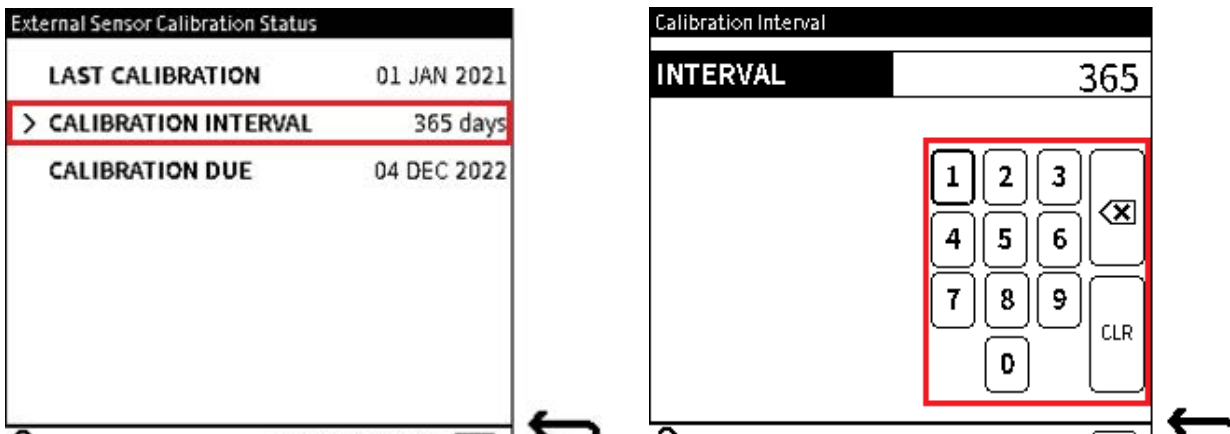

1. Select **CALIBRATION INTERVAL** from the **External Sensor Calibration Status** screen.
2. Enter a calibration interval between 7 and 548 (days).
Select ✓ to enter the value.

14.9.2.3 How to Change the Calibration Due Date

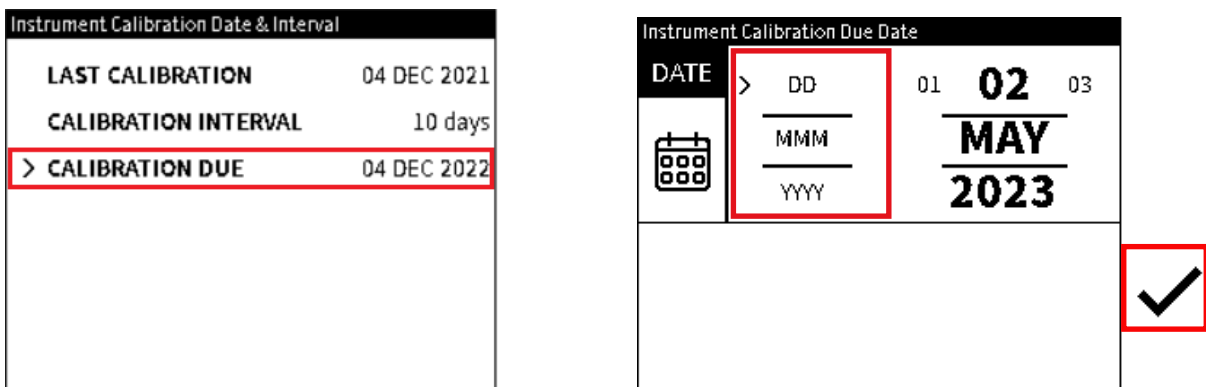

1. Select **CALIBRATION DUE** from the **Instrument Calibration Date & Interval** screen.
2. Select the day, month, and year (see Section 1.16.3 on page 16).
To change the value, select the row of the variable. Tap the value on the left of the current value to decrease the value and the value on the right to increase the value. Repeat pressing of either left or right value decreases or increases the selected current value.
Select ✓ to confirm the changes.
Tap either the left or right value again and again to decrease or increase the selected value.
Select ✓ to confirm the changes.

15. Files System

The **Files** system menu gives access to all user files in the internal memory of the DPI610E. The Dashboard screen gives access to this function which shows the structure of folders that organize the files.

15.1 How to Get to the Files System Menu

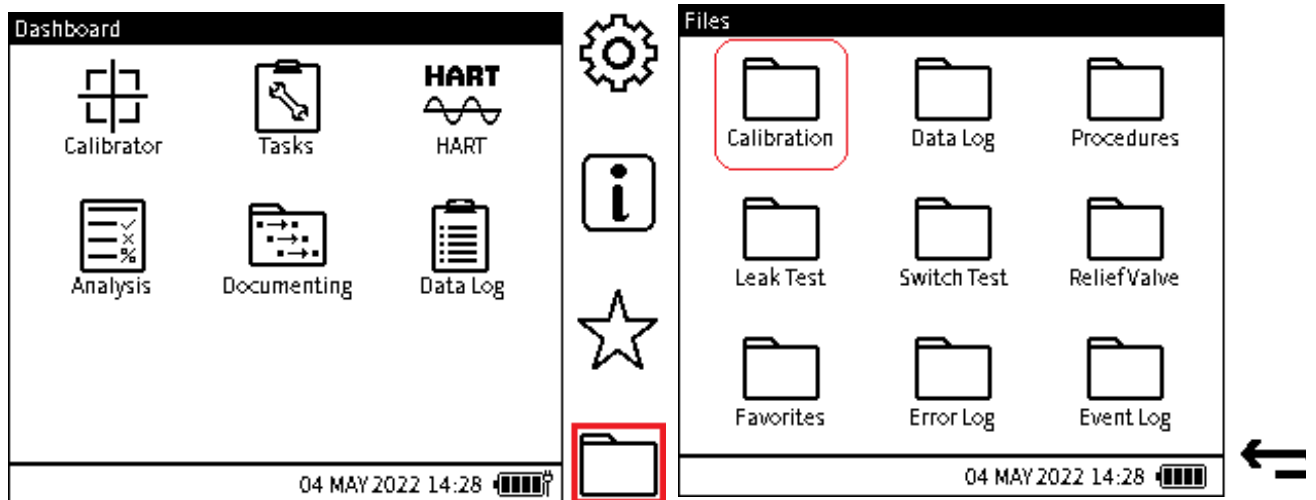

1. Select the **Files** Softkey from the Dashboard.
2. Select the wanted folder from the **Files** menu. In this example, the Calibration folder is selected.

15.1.1 The Files System Screen Options

Option	Description
Calibration	Export / Look at instrument calibration files
Data Log	Look at / Open / Delete data log files
Procedures	Look at / Delete test procedures, assets, and results files
Leak Test	Look at saved leak test result files
Switch Test	Look at saved switch test result files
Relief Valve	Look at saved relief valve test result files
Favorites	Look at a task or channel setup saved as a Favorite
Error Log	Export / Look at error log files
Event Log	Export / Look at event log files

15.2 Calibration

When the **Calibration** folder is selected, calibration files that were exported in the past will also be in the list.

If no export has been done before, select the **Export**  Softkey to take the calibration files stored on the unit and export them. There are three types of calibration files:

- **Factory Calibration** – this is the default calibration done on the instrument in the factory before it is sent. Its values saved in permanent storage and cannot be changed or removed by the user.

Chapter 15. Files System

- **Current Calibration** – the instrument uses this calibration data. If the instrument is new and has not been used, the Current calibration will be the Factory calibration. After calibration adjustment has been done on the instrument, this new data will replace the factory calibration data as the new Current calibration. New calibrations will replace this user calibration data.
- **Backup Calibration** – if the **Backup** calibration function is used (See Section 14.5 on page 242), a copy of the Current Calibration data is saved as a Backup data file.

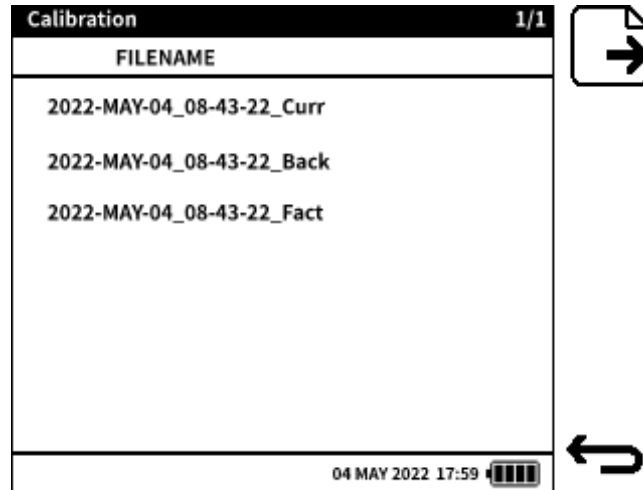



Figure 15-1: Calibration Files screen

15.3 Data Log

Select the **Data Log** folder, to show a list of log files saved in the memory of the instrument. The log files are found and their contents shown by this menu.

Erase unwanted log files by the use of either the **Single Delete**  Softkey for single files, or the **Delete All**  Softkey for all log files.

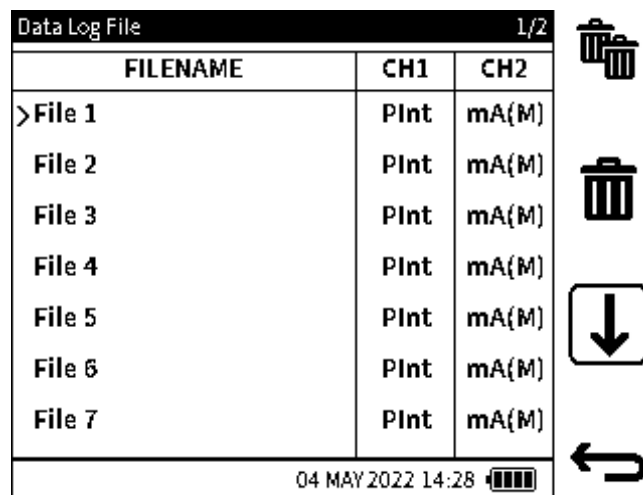

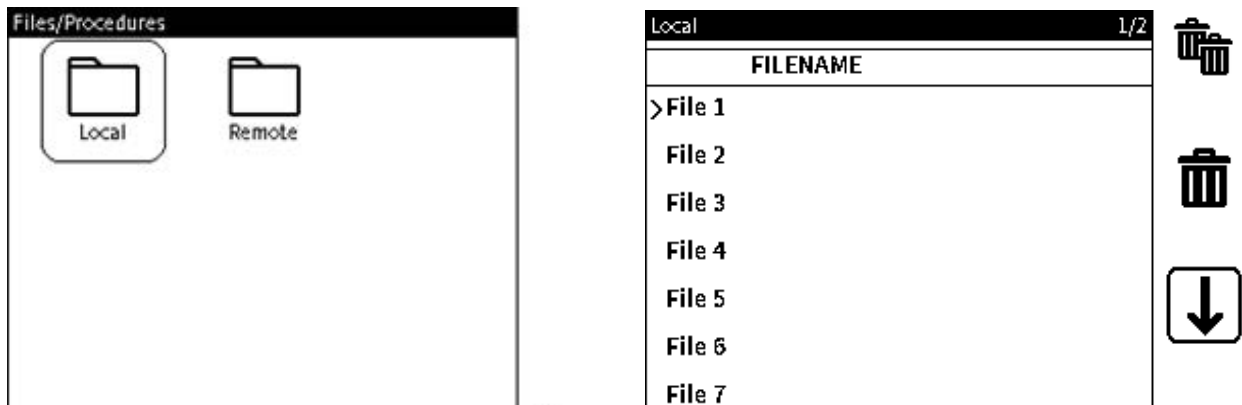

Figure 15-2: Data Log files screen

15.4 Procedures



The **Procedures** option gives a list of available test procedures made and saved on the instrument by the **Documenting** function (see Chapter 12 on page 171). To look at the list of available internal procedures, select the **Local (Procedures)** sub-folder. Select the **Remote** sub-folder to look at a list of 4Sight2 procedures in memory.

Note: Only the list of files can be looked at in the **Files** application. Use the **Single Delete**  Softkey to erase individual files or the **Delete All**  Softkey to erase all files in the sub-folder:



15.5 Leak Test

The **Leak Test Results** folder shows a list of saved result-files from completed leak tests. These files are read-only: open the file on a PC to look at test result data.

Use either the **Single Delete**  Softkey (to erase individual files) or the **Delete All**  Softkey (to erase all files in the sub-folder).

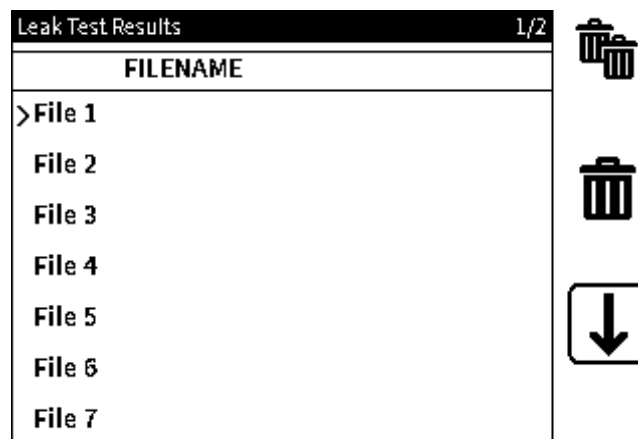



Figure 15-3: Leak Test Results Screen

15.6 Switch Test

The **Switch Test Results** folder shows a list of saved result files from completed switch tests. These files are read-only: open the file on a PC to look at test result data.

Use either the **Single Delete**  Softkey (to erase individual files) or the **Delete All**  Softkey (to erase all files in the sub-folder).

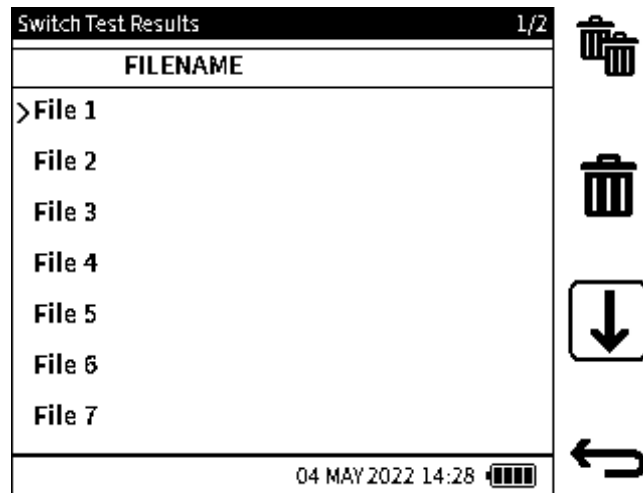



Figure 15-4: Switch Test files screen

15.7 Relief Valve

The **Relief Valve Results** folder shows a list of saved result-files from completed Relief Valve tests. These files are read-only: open the file on a PC to look at test result data.

Use either the **Single Delete**  Softkey (to erase individual files) or the **Delete All**  Softkey (to erase all files in the sub-folder).

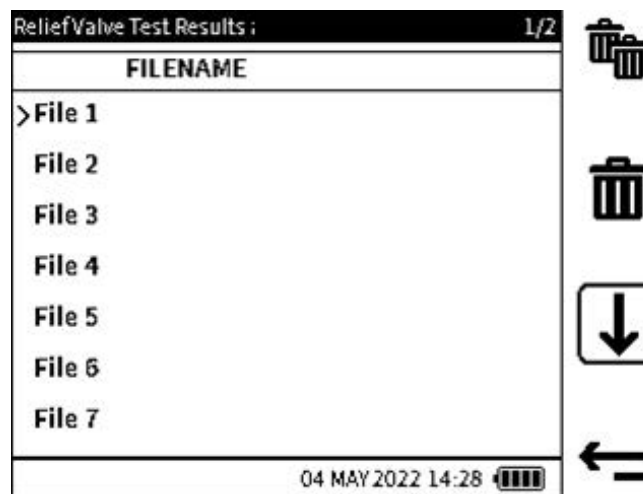

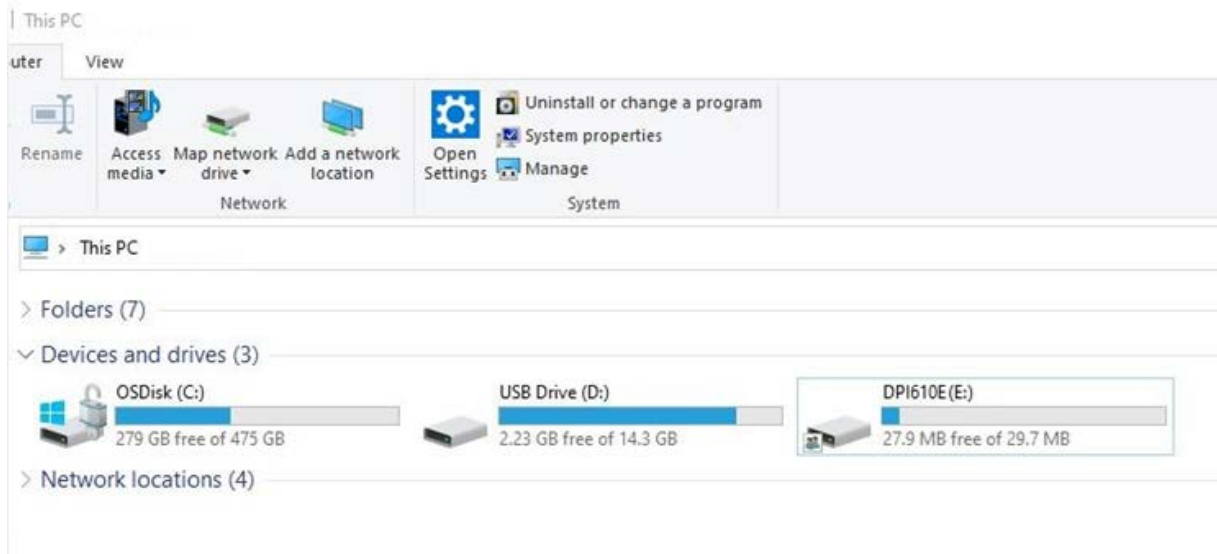

Figure 15-5: Switch Test files screen

15.8 How to View the File System on a PC

To access the contents of the internal memory of the DPI610E: first connect the DPI610E, by the use of the supplied micro-USB cable, to the USB port of the PC. A compatible mini-USB cable can be used if the supplied micro-USB cable is not available. From the device Dashboard, select the **Settings**  Softkey, then select **USB**: change the USB setting to 'Storage' if not set. This lets the DPI610E device be available as a mass storage drive, identified as 'DPI610E' in File Explorer on the PC.



Use the folder structure to find the location of files. The **HART** folder is different, because its folder and contents can only be found and looked at from a PC.

It is possible to make copies of files in the device memory and move them to a different file location on the PC. Files can also be erased, to increase storage capacity on the device.

Double-tap on the DPI610E drive and select the wanted **File System** folder from the root directory.

The screenshot shows the contents of the 'DPI610E (E:)' drive. The navigation pane shows 'This PC > DPI610E (E:)'.

Name	Date modified	Type	Size
Calibration		File folder	
DataLog		File folder	
DocData		File folder	
ErrorLog		File folder	
EventLog		File folder	
Favorites		File folder	
HART		File folder	
LeakTest		File folder	
SwitchTest		File folder	
DK0492.raw	01/02/2022 11:29	RAW File	1,642 KB

15.9 Favorites, Error Log and Event Log

Refer to Chapter 17, “Favorites Menu,” on page 265 for information about how to use the **Favorites** function.

Refer to Section 16.8 on page 261 for information about how to use the **Error Log** function.

Refer to Section 16.9 on page 262 for information about how to use the **Event Log** function.

16. Status Menu

16.1 Status Menu Options

The **Status** (Information) menu is a read-only menu that gives important information about the DPI610E instrument. Use the Dashboard to select this menu, which has these options:

Table 16-1: Status Menu Options

Option	Description
SOFTWARE BUILD	View the software build installed on the instrument
CALIBRATION	View the Calibration information (instrument and external sensors)
BATTERY	View the battery status
MEMORY	View the internal memory status
SENSOR	View the Sensor information (instrument and external sensors)
ERROR LOG	Export (and look at) error log files
EVENT LOG	Export (and look at) event log files

16.2 How to Show the Status Menu Screen

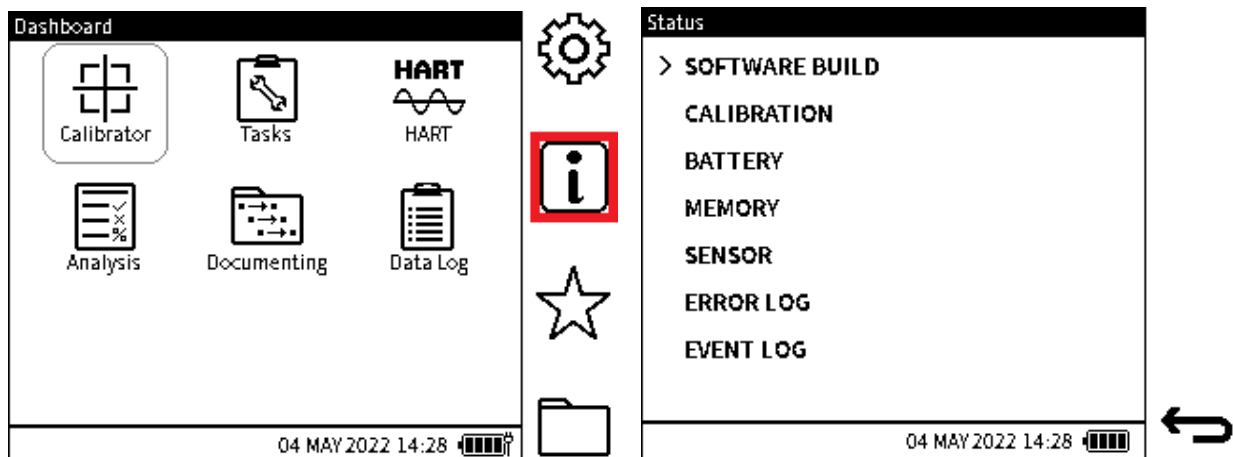

1. Select the **Status** (Information) Softkey from the Dashboard.
2. The screen shows **Status** menu options. To select the row that has the wanted option, tap on the row or use the Navigation Pad.

16.3 SOFTWARE BUILD

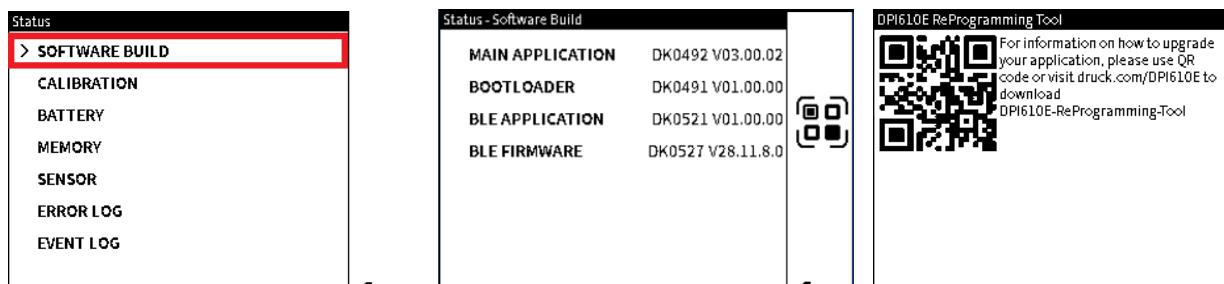

1. In the **Status** menu screen select the **SOFTWARE BUILD** row, to show the **Status - SOFTWARE BUILD** screen.

Chapter 16. Status Menu

- 2. The **Status - SOFTWARE BUILD** screen shows the **MAIN APPLICATION** (DK492) and the **BOOTLOADER** (DK491) build version information.

BLE APPLICATION and **BLE FIRMWARE** relate to BLUETOOTH in the device.

In addition, a QR  Softkey is available which when selected, goes to the information screen for the programming tool. This screen gives the URL and QR code. This code takes the user to where the software programming tool can be downloaded, with instructions on how to use it to do software upgrades.

16.4 CALIBRATION

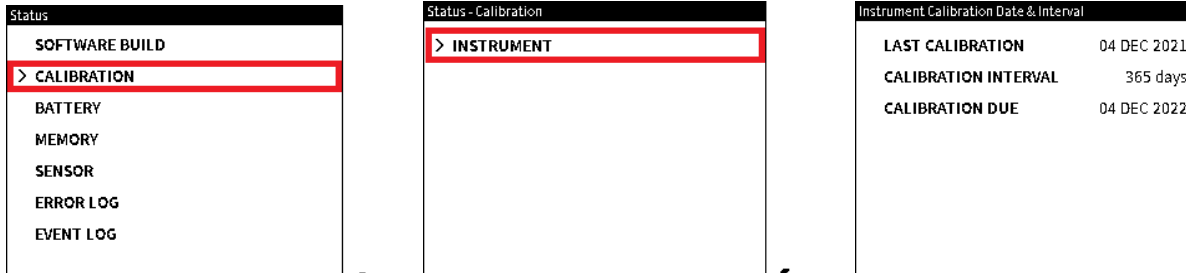

- 1. In the **Status** menu screen select the **CALIBRATION** row, to show the **Status - Calibration** screen.
- 2. The **Status - Calibration** screen shows the **INSTRUMENT** (or sensor) option.
Note: For the **EXTERNAL PRESSURE SENSOR** option to be available in this screen, the **EXT pressure** must be set in the **Calibrator** menu. (See Section 9.1.6 on page 133) or **EXTERNAL RTD** function (see Section 9.2.4 on page 139).
- 3. To look at the instrument (or sensor) data. Select the **Back**  Softkey to go back to the **Status - Calibration** menu.

16.5 BATTERY

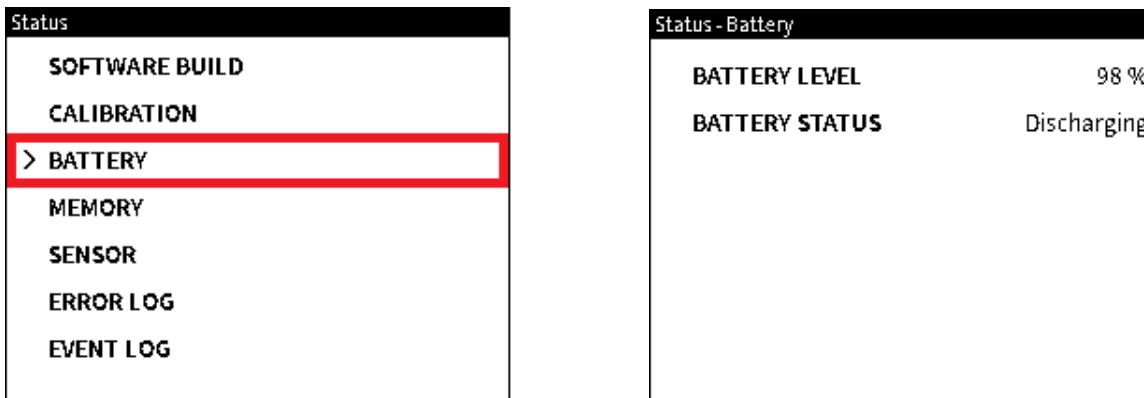

- 1. In the **Status** menu screen select the **BATTERY** row, to show the **Status - Battery** screen.
- 2. The **Status - Battery** screen shows the instrument battery level and if the battery gives power (discharging) or receives power (being charged).

16.6 MEMORY

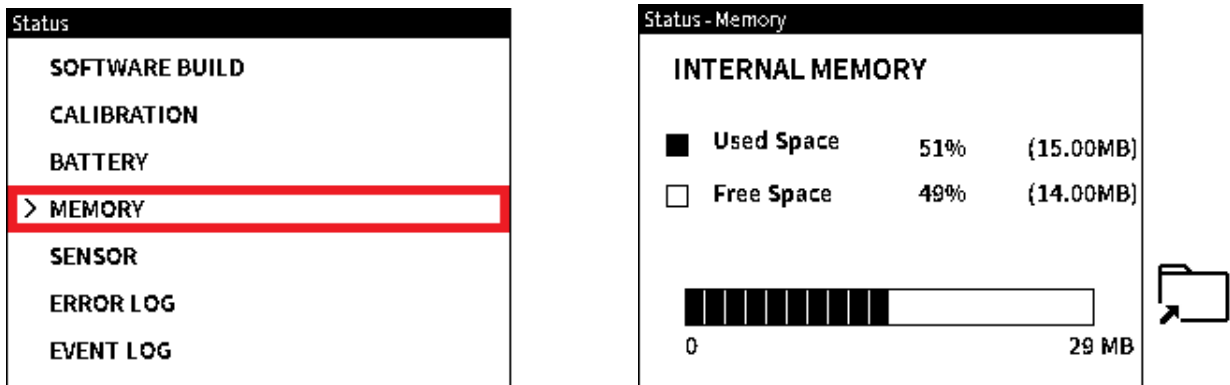

1. In the **Status** menu screen select the **MEMORY** row, to show the **Status - Memory** screen. The **Status - Memory** screen shows the free and used space in the instrument's internal memory.
2. Tap on the **Status Memory**  icon to get access to instrument memory. It can be necessary to make more memory available for a new file.

16.7 SENSOR

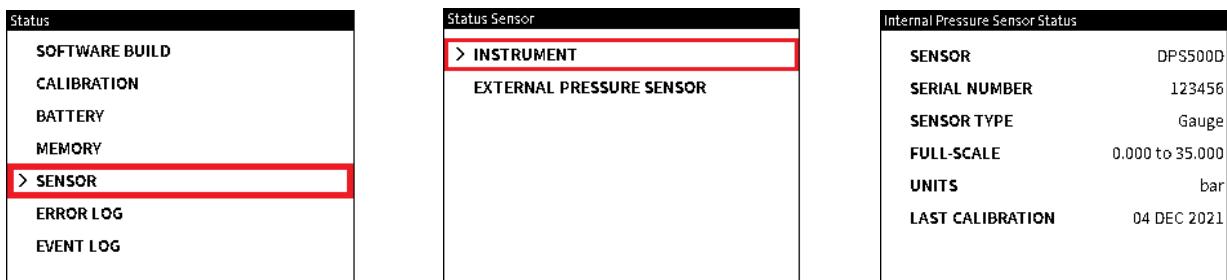

1. In the **Status** menu screen select the **SENSOR** row to show the **Status - Sensor** screen.
2. The display shows the **Status - Sensor** screen because the instrument has been set to use an external sensor (see Section 9.1.6 on page 133.)

Note: For the **EXTERNAL SENSOR** option to be available in this screen, the **EXT pressure** or **RTD** function must be set in the **Calibrator** menu and the sensor successfully connected: refer to Chapter 9 on page 131 for information.

3. View the sensor details.

Select the **Back**  Softkey to go back to the **Status - Sensor** screen.

16.8 ERROR LOG

The DPI610E makes a data record of information when it has operational software or firmware problems.

Note: Each time the **ERROR LOG** is selected, an export of the currently logged errors is automatically created as a CSV file. The **Error Log** screen shows this export file but this file can only be opened if moved and looked at from a PC: (refer to Section 10.6.1 on page 161 for how to find and read these files).

16.8.1 How to Export and View Exported Error Log Files

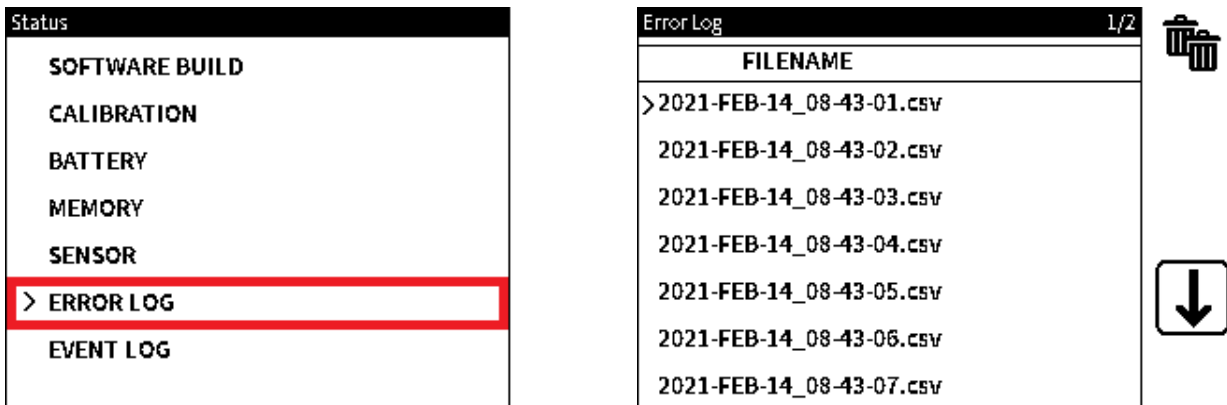

1. Select the **ERROR LOG** from the **Status** menu screen.
Note: The screen will show a “Please Wait” popup message while the log file is made. It can take up to 1 minute to complete.
2. Look at the list of **ERROR LOG** files.
To erase all files in the list, tap (or push the related Softkey) the **Multiple trashcan (Delete All)**  icon. The screen shows a message window with the text, “Delete all files?”. Select **OK** or **Cancel**.

Tap the down  icon to show one more page of available files.

Tap the **Back**  icon to go back to the **Status** screen.

16.9 EVENT LOG

The DPI610E records information about important events that occur on the instrument while in operation. These events can include errors and warnings.

Note: Each time the **EVENT LOG** is selected, an export of the logged system events is automatically made as a CSV file. The **Event Log** screen shows this export file but this file can only be opened if moved and looked at from a PC: (refer to Section 10.6.1 on page 161 for how to find and read these files).

16.9.1 How to Export and View Exported Event Log Files

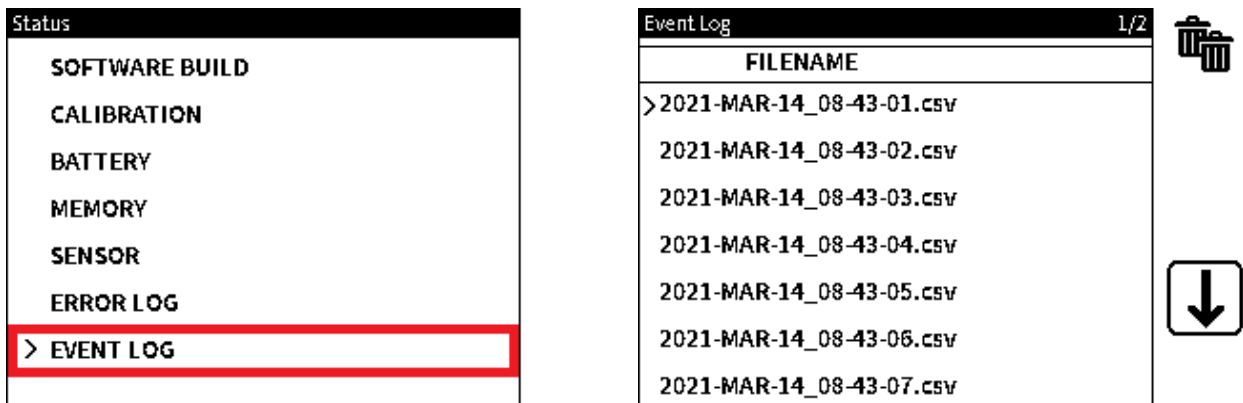

1. Select the **EVENT LOG** from the **Status** menu screen.
Note: The screen shows a ‘Please Wait’ popup message while the log file is made. It can take up to 1 minute to complete.

2. Look at the list of **Event Log** files.

To erase all files in the list, tap (or push the related Softkey) the **Multiple trashcan (Delete all)**  icon. The screen shows a message window with the text, "Delete all files?". Select **OK** or **Cancel**.

Tap the down  icon to show one more page of available files.

Tap the **Back**  icon to go back to the **Status** screen.

17. Favorites Menu

17.1 Favorites Menu Options

A task in operation or a channel setup can be saved as a Favorite. This includes all channel setup parameters, such as measurement units, Process options, digit resolution and other related setups.

This saved setup can be selected to automatically load and set the Calibrator task. Up to 10 Favorite setups can be saved.

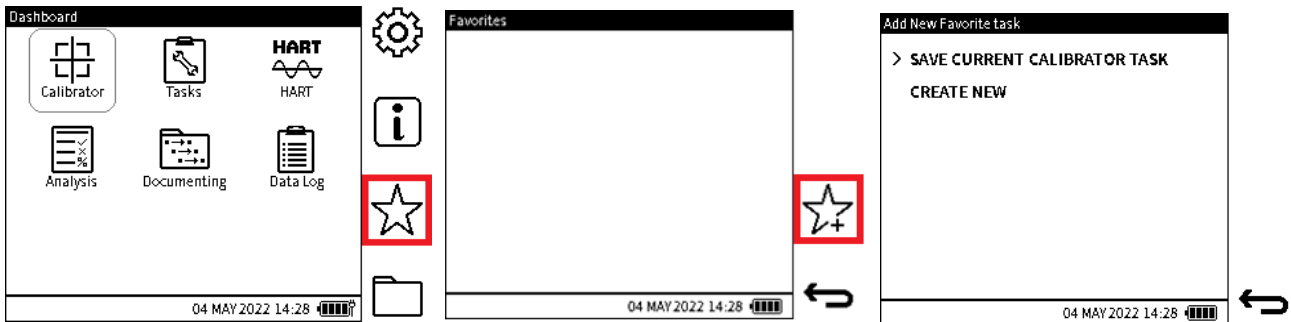

1. Select the **Favorites** icon or Softkey from the Dashboard.
2. The display shows the **Favorites** screen.

The list on this screen will be empty if no Favorites are available.

Select the **Add New** ☆ Softkey to show the **Add New Favorite task** screen.

3. There are two methods available to save a Favorite setup:
 - **SAVE CURRENT CALIBRATOR TASK**. See Section 17.1.1 on page 265.
 - **CREATE NEW** to save a new setup. See Section 17.1.2 on page 266.

Tap on a row to select the method.

17.1.1 Save Current Calibrator Task

To save the current Calibrator task and all its settings as a Favorite, first make sure the wanted setup has been made in the Calibrator application.

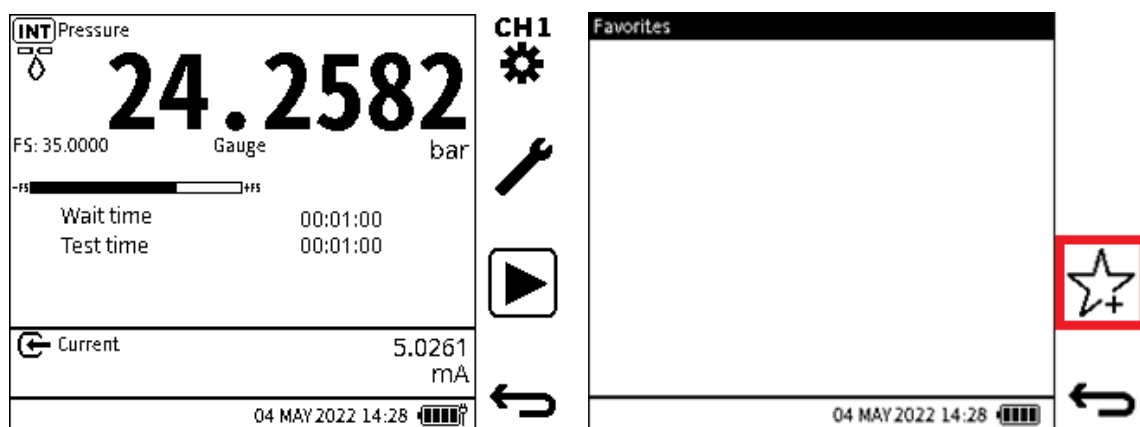

1. This example screen relates to a Calibrator task for a Leak Test and Current Measure.

Select the **Back** ↩ icon on this screen to show the Dashboard screen.

Chapter 17. Favorites Menu

Select the **Favorites** ☆ Softkey from the Dashboard. (For this screen image see Step 1 in Section 17.1 on page 265).

2. Select the **Add New** ☆ Softkey in the **Favorites** screen.

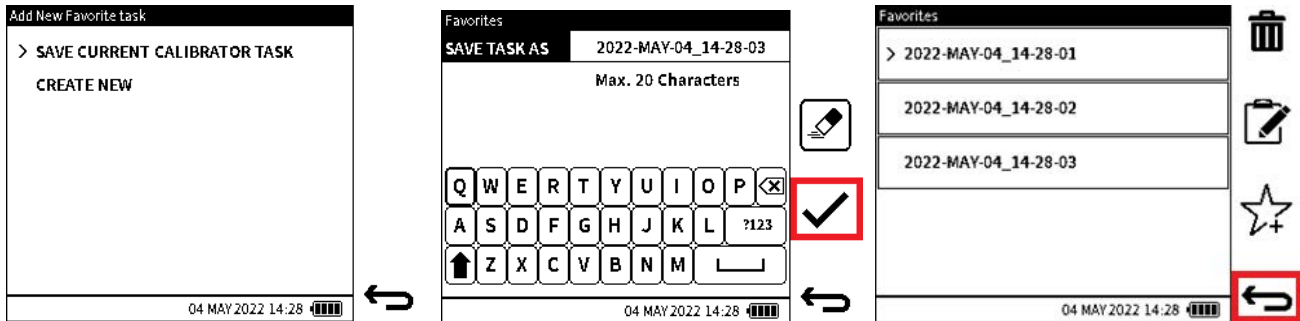

3. Select the **SAVE CURRENT CALIBRATOR TASK** option in the **Add New Favorite task** screen.
4. Enter a new file name into the **SAVE TASK AS** field or accept the default file name that uses the current date. Maximum characters = 20. To save the setup select the **Tick** ✓ Softkey.
5. The **Favorites** screen shows the new setup file in a list.

17.1.2 Save New Configuration as Favorite

This option lets a manual setup of the individual channels be done in the **Favorites** menu.

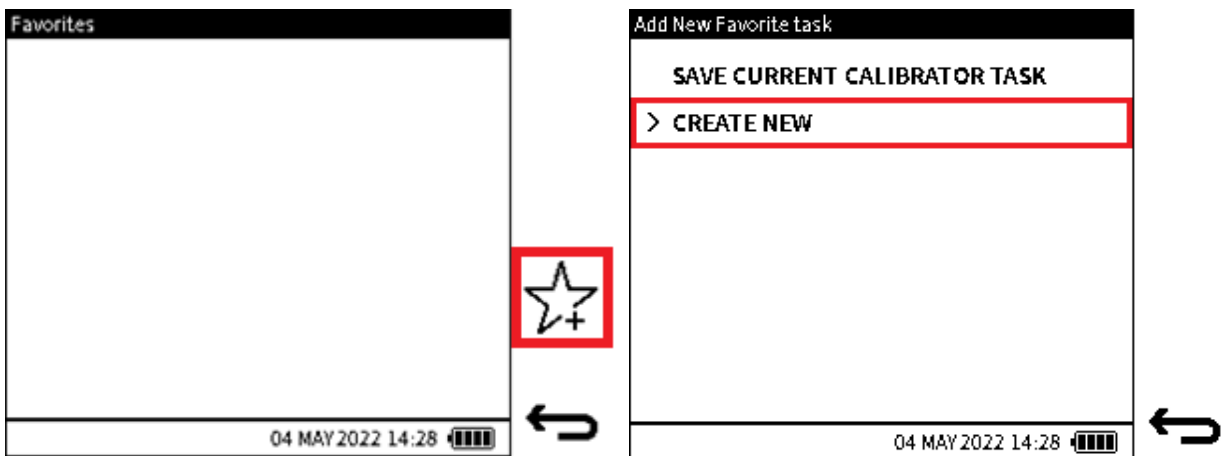



1. Select the **Favorites** ☆ Softkey from the Dashboard. (For this screen image see Step 1 in Section 17.1 on page 265).

Select the **Add New** ☆ Softkey from the **Favorites** screen.

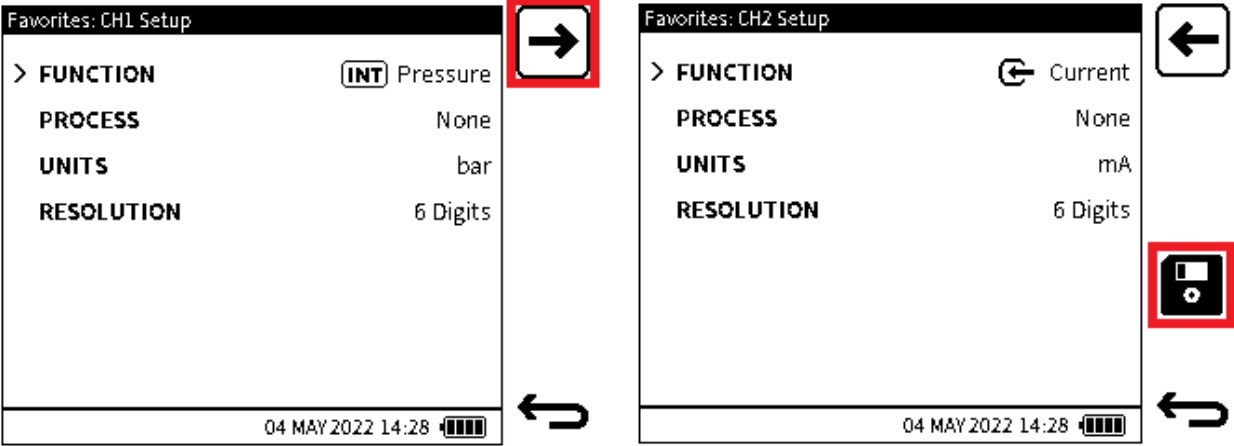
2. Select the **CREATE NEW** option.



- 3. The **Favorites CH1 Setup** screen will be in the setup in use. Select any of the setup parameters to change. When the setup is complete, select the **Next**  Softkey to move to the **Favorites CH2 Setup** screen.
- 4. Change any of the setup parameters in the **Favorites CH2 Setup** screen, if necessary, and then select the **Save**  Softkey.

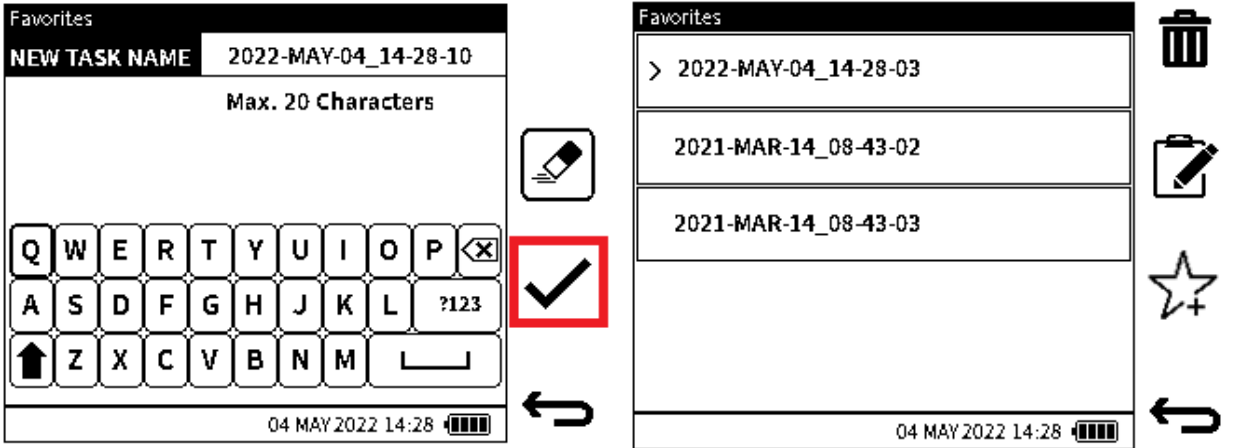

- 5. Enter the new file name into the **NEW TASK NAME** field **Favorites** screen (or accept the default file name that uses the date). Maximum characters = 20. Select the **Tick**  Softkey to save the setup.
- 6. The **Favorites** screen shows the new setup file in its list.



17.2 To Load a Favorites Setup

From the **Favorites** menu, go to the wanted saved **Favorites** file: tap the filename to select the file or use the Up/Down button on the Navigation Pad. Tap again to load the setup or push the **Enter**  button if using the Navigation Pad.

17.3 Edit an Existing Favorite File

From the **Favorites** menu, go to the wanted saved **Favorites** file: tap the file name to select the file or use the Up/Down button on the Navigation Pad.

Chapter 17. Favorites Menu

Select the **Edit** Softkey  and make changes to the **Favorites** file setup. When the change is done, select the **Save**  Softkey to save the changes made.

17.4 Delete Favorite Files

From the **Favorites** menu, go to the wanted **Favorites** file: tap on the file name to select the file or use the Up/Down button on the Navigation Pad. Select the **Delete**  Softkey to erase the file.

17.5 Transferring Favorite Files

A PC can access the **Favorite** setup files through the USB cable connection. They will be in the **Favorites** folder in the root directory of the DPI610E. Use the Windows **Copy** command to move a copy of a file to another folder. These setup files can then be moved into another DPI610E instrument and used in that instrument.

Note: Care must be taken in the movement of these files: make sure the DPI610E share the same supported functionality. For example, do not try to move a setup file that uses the Barometer function, from a pneumatic DPI610E variant, to a hydraulic type which cannot use the Barometer function.

17.6 How to get access to Favorite Files through the File System

Saved **Favorites** setup files can be looked at in the File System menu by the selection of the **File System**  Softkey from the Dashboard and the selection of the **Favorites** folder. Refer to Section 15.8 on page 256 for more information.

18. General Specification

Go to our website for the Datasheet that gives the technical specifications for all types of the DPI610E:

www.druck.com

18.1 Maximum Leak Rates

18.1.1 Pneumatic Version

Pressure (barg)	Leak Rate (mbar/min)	Leak Rate (%Full Scale)	Test Wait Time (minutes)
35	17.5	0.05	2
20	10	0.05	2
10	5	0.05	2
7	3.5	0.05	2
3.5	1.75	0.05	2
2	1	0.05	4
1	1	0.10	5
0.35	0.35	0.10	5

Test Time = 1 minute

18.1.2 Hydraulic Version

Pressure (barg)	Leak Rate (mbar/min)	Leak Rate (%Full Scale)	Test Wait Time (minutes)*
1000	500	0.05	5
700	350	0.05	5
350	175	0.05	5
200	100	0.05	5
135	68	0.05	5
100	50	0.05	5
70	35	0.05	5

Test Time = 1 minute

Note: The hydraulic leak test depends on the unit being correctly primed to remove the air from the system (Refer to Chapter 2). Compressing trapped air gives adiabatic effects which seem like (but are not) leaks, as the pressure drops on cooling.

*Recommended wait time is 5 minutes. Longer or shorter wait times will affect the leak rates.

18.2 Open Source Software Licenses

Two files are available with the software installation:

1568-notices-report-08_08_2022_17_04.txt covers DK0491 DPI610E Bootloader.

1563-notices-report-08_08_2022_16_01.txt covers DK0492 DPI610E Main Application.

19. Manufacturer

19.1 Contact details

Druck Limited
2 Fir Tree Lane
Groby
Leicester
LE6 0FH
United Kingdom

Tel: +44 (0)116 231 7100
www.Druck.com

Appendix A. COMPLIANCE STATEMENTS

A.1 FCC (USA)

A.1.1 Federal Communication Commission Interference Statement

This equipment has been tested and found to comply with the limits for a Class B digital device, pursuant to Part 15 of the FCC Rules. These limits are designed to provide reasonable protection against harmful interference in a residential installation. This equipment generates, uses, and can radiate radio frequency energy and, if not installed and used in accordance with the instructions, may cause harmful interference to radio communications.

However, there is no guarantee that interference will not occur in an installation. If this equipment does cause harmful interference to radio or television reception, which can be determined by turning the equipment off and on, the user is encouraged to try to correct the interference by one of the following measures:

- Reorient or relocate the receiving antenna.
- Increase the separation between the equipment and receiver.
- Connect the equipment into an outlet on a circuit different from that to which the receiver is connected.
- Connect the equipment into an outlet on a circuit different from that to which the receiver is connected.

FCC Caution: Any changes or modifications not expressly approved by the party responsible for compliance could void the user's authority to operate this equipment.

This device complies with Part 15 of the FCC Rules. Operation is subject to the following two conditions:

1. This device may not cause harmful interference; and,
2. This device must accept any interference received, including interference that may cause undesired operation.

A.1.2 FCC Radiation Exposure Statement

This product complies with the US portable RF exposure limit set forth for an uncontrolled environment and is safe for intended operation as described in this manual. Further RF exposure reduction can be achieved if the product is kept as far as possible from the user body or is set to a lower output power if such function is available.

This transmitter must not be co-located or operated in conjunction with any other antenna or transmitter.

A.2 CANADA

A.2.1 ISED Canada Statement

This device complies with Industry Canada's license-exempt RSSs. Operation is subject to the following two conditions:

1. This device may not cause interference; and
2. This device must accept any interference, including interference that may cause undesired operation of the device.

Le présent appareil est conforme aux CNR d'Industrie Canada applicables aux appareils radio exempts de licence. L'exploitation est autorisée aux deux conditions suivantes:

1. l'appareil ne doit pas produire de brouillage;

Appendix A. COMPLIANCE STATEMENTS

2. l'utilisateur de l'appareil doit accepter tout brouillage radioélectrique subi, même si le brouillage est susceptible d'en compromettre le fonctionnement.

A.2.2 Radiation Exposure Statement

The product complies with the Canada portable RF exposure limit set forth for an uncontrolled environment and are safe for intended operation as described in this manual. The minimum separation distance for portable use is limited to 15mm assuming use of antenna with 2 dBi of gain. The further RF exposure reduction can be achieved if the product can be kept as far as possible from the user body or set the device to lower output power if such function is available.

A.2.3 Déclaration d'exposition aux radiations

Le produit est conforme aux limites d'exposition pour les appareils portables RF pour les Etats-Unis et le Canada établies pour un environnement non contrôlé. La distance de séparation minimale pour l'utilisation portative est limitée à 15mm en supposant l'utilisation de l'antenne avec 2 dBi de gain. Le produit est sûr pour un fonctionnement tel que décrit dans ce manuel. La réduction aux expositions RF peut être augmentée si l'appareil peut être conservé aussi loin que possible du corps de l'utilisateur ou que le dispositif est réglé sur la puissance de sortie la plus faible si une telle fonction est disponible.

Office Locations



<https://druck.com/contact>

Services and Support Locations



<https://druck.com/service>