

# Series 20/20S/20H/20HS Pilots

Instruction Manual (Rev.E)

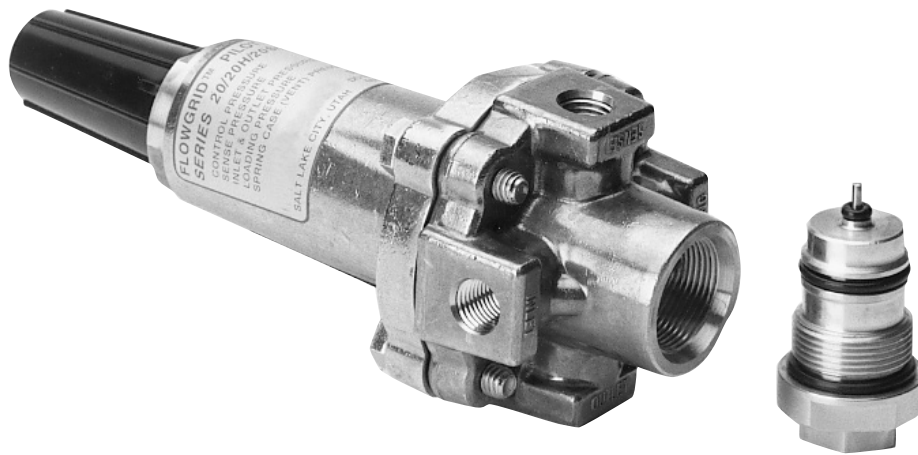

**THESE INSTRUCTIONS PROVIDE THE CUSTOMER/OPERATOR WITH IMPORTANT PROJECT-SPECIFIC REFERENCE INFORMATION IN ADDITION TO THE CUSTOMER/OPERATOR'S NORMAL OPERATION AND MAINTENANCE PROCEDURES. SINCE OPERATION AND MAINTENANCE PHILOSOPHIES VARY, BAKER HUGHES COMPANY (AND ITS SUBSIDIARIES AND AFFILIATES) DOES NOT ATTEMPT TO DICTATE SPECIFIC PROCEDURES, BUT TO PROVIDE BASIC LIMITATIONS AND REQUIREMENTS CREATED BY THE TYPE OF EQUIPMENT PROVIDED.**

**THESE INSTRUCTIONS ASSUME THAT OPERATORS ALREADY HAVE A GENERAL UNDERSTANDING OF THE REQUIREMENTS FOR SAFE OPERATION OF MECHANICAL AND ELECTRICAL EQUIPMENT IN POTENTIALLY HAZARDOUS ENVIRONMENTS. THEREFORE, THESE INSTRUCTIONS SHOULD BE INTERPRETED AND APPLIED IN CONJUNCTION WITH THE SAFETY RULES AND REGULATIONS APPLICABLE AT THE SITE AND THE PARTICULAR REQUIREMENTS FOR OPERATION OF OTHER EQUIPMENT AT THE SITE.**

**THESE INSTRUCTIONS DO NOT PURPORT TO COVER ALL DETAILS OR VARIATIONS IN EQUIPMENT NOR TO PROVIDE FOR EVERY POSSIBLE CONTINGENCY TO BE MET IN CONNECTION WITH INSTALLATION, OPERATION OR MAINTENANCE. SHOULD FURTHER INFORMATION BE DESIRED OR SHOULD PARTICULAR PROBLEMS ARISE WHICH ARE NOT COVERED SUFFICIENTLY FOR THE CUSTOMER/OPERATOR'S PURPOSES THE MATTER SHOULD BE REFERRED TO BAKER HUGHES.**

**THE RIGHTS, OBLIGATIONS AND LIABILITIES OF BAKER HUGHES AND THE CUSTOMER/OPERATOR ARE STRICTLY LIMITED TO THOSE EXPRESSLY PROVIDED IN THE CONTRACT RELATING TO THE SUPPLY OF THE EQUIPMENT. NO ADDITIONAL REPRESENTATIONS OR WARRANTIES BY BAKER HUGHES REGARDING THE EQUIPMENT OR ITS USE ARE GIVEN OR IMPLIED BY THE ISSUE OF THESE INSTRUCTIONS.**

**THESE INSTRUCTIONS ARE FURNISHED TO THE CUSTOMER/OPERATOR SOLELY TO ASSIST IN THE INSTALLATION, TESTING, OPERATION, AND/OR MAINTENANCE OF THE EQUIPMENT DESCRIBED. THIS DOCUMENT SHALL NOT BE REPRODUCED IN WHOLE OR IN PART WITHOUT THE WRITTEN APPROVAL OF BAKER HUGHES.**

# Scope

This manual provides installation, operation and maintenance instructions for the Mooney Series 20/20S/20H/20HS Pilots. The manual is divided into the following sections:

## Table of Contents

Product Description .....	1
Materials of Construction .....	2
Specifications .....	2-3
Pilot Markings .....	3
Nameplate Information.....	3
Piping Schematics.....	4
Installation.....	5
Maintenance.....	6

## Product Description

The **Mooney™** Series 20 Pilot is a reversible pressure control regulator designed for use on Mooney **Flowgrid™** and **FlowMax™** valves. It can be used for pressure reducing (PRV), backpressure (BPV or Relief), and differential pressure applications. The Series 20 Pilot is designed for both gas and liquid applications.

**Series 20** - Brass construction with 3 to 450 psi (0.20 bar - 31 bar) control pressure range.

**Series 20H** - High pressure brass construction with a 200 to 900 psi (14 bar - 62 bar) control pressure range.

**Series 20S** - Stainless steel construction with a 3 to 450 (0.20 bar - 31 bar) control pressure range.

**Series 20HS** - High pressure, stainless steel construction with a 200 to 900 psi (14 bar - 62 bar) control pressure range.

The parts in all constructions are interchangeable. The high pressure constructions (Series 20H and 20HS) differ from the Series 20 and 20S with the addition of a diaphragm spacer assembly that reduces the effective area of the diaphragm and increases the spring range of the black and green springs.

## General Description

(Refer to Figure 1)

**Spring Housing (1):** The Pilot Spring Housing is provided with a 1/4 inch NPT vent connection which may be piped to a safe area or pressure loaded for remote control of the pressure setting. The Spring Housing may also be pressurized for use in differential pressure control or remote control applications. The Main Spring may be changed by simply removing the Closing Cap (1A).

**Body Insert Assembly (2):** A removable Body Insert Assembly (cartridge), at the bottom of the Pilot Body, contains the inner valve mechanism. The inner valve is reversible so that the Main Spring will either open the valve (Pressure Reducing mode) or close the valve (Back Pressure or Relief mode). The cartridge may be replaced with a spare unit for fast trouble shooting or repair. The Body Insert Assembly is also field repairable.

**Inlet and Loading Ports (3):** The INLET port is common with the LOADING port through an internal passage in the pilot. A Restrictor is normally connected directly to the INLET port when used with a Mooney Flowgrid or unloading type regulator. The LOADING port is used to connect and mount the pilot to the loading chamber of the Flowgrid valve to be operated.

**Sensing Port (4):** The Series 20 Pilot has separate SENSE and OUTLET connections. The SENSE connection is “static” which means that there is no flow in the sensing line and the true pipeline pressure is measured at the diaphragm.

**Outlet Port (5):** The OUTLET port must be connected to the valve outlet or outlet pressure system. The OUTLET port is also used to connect and mount the pilot to the loading chamber of the Mooney FlowMax valve to be operated. Separate SENSE and OUTLET ports make piping easier and facilitates piping working monitor and standby monitor systems using a variety of piping and control schemes.

**Diaphragm Spacer Assembly (6):** The addition of this assembly converts the Series 20 & 20S Pilot into the high pressure Series 20H & 20HS. It reduces the pilot diaphragm area and increases the spring range of the black and green springs.

**Note:** *The pilot is designed for use with an external restrictor (refer to Principle of Operation Section of this manual). The restrictor may be a needle valve or rotary scratch valve such as the Type 24 Mooney Restrictor and would normally be installed in the pilot Inlet connection (3).*

Materials of Construction Series 20 and 20S	
Body & Spring Housing	Forged Brass or Stainless Steel
Body Insert & Closing Cap	Brass or Stainless Steel
Orifice	Stainless Steel or Delrin
Plug & Stem	Nitrile Stainless Steel
Diaphragm	Nitrile/Nylon or Viton/Nylon
O-Rings	Nitrile or Viton

Table 1

Materials of Construction Series 20H & 20HS	
Body & Spring Housing	Forged Brass or Stainless Steel
Body Insert & Closing Cap	Brass or Stainless Steel
Diaphragm Spacer Assembly	Stainless Steel
Orifice	Stainless Steel or Delrin <sup>(1)</sup>
Plug & Stem	Nitrile/Stainless Steel/Viton/ Stainless Steel/Stainless Steel
Diaphragm	Nitrile/Nylon or Viton/Nylon
O-Rings	Nitrile or Viton

Table 2

<sup>(1)</sup> Delrin Orifice primarily used in High Pressure BPV applications only.

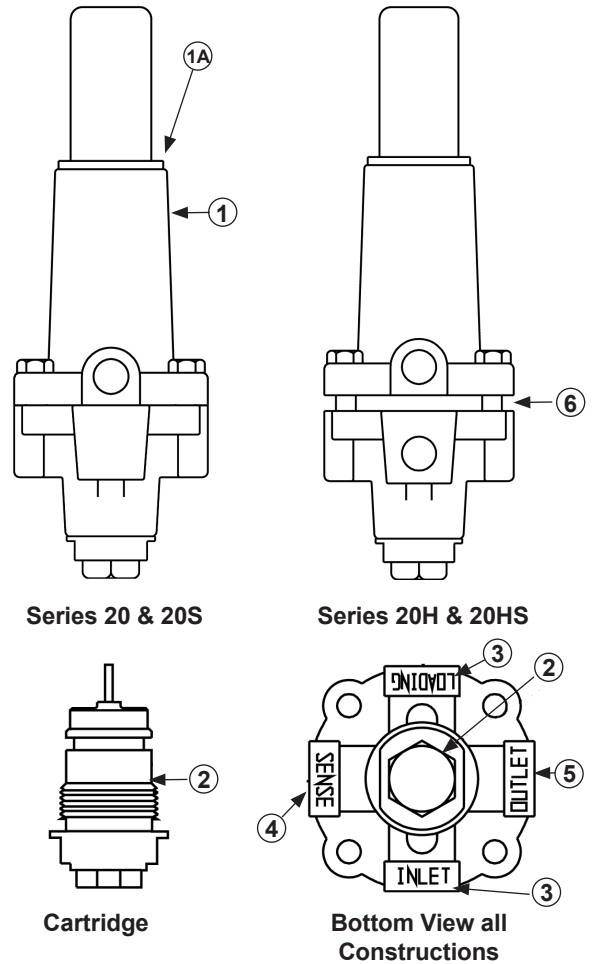

Figure 1

Specifications All Series 20 Pilots	
Control Application	Pressure Reducing (PRV) & Back Pressure (BPV)
Orifice Size	0.15 in (3.81 mm)
Connections	1/4 in NPTF
Temperature	Working -20°F to 150°F (-6.7 °C to 65.7°C) Emergency -40°F to 200°F (-40°C to 93.3°C)
Maximum Inlet Pressure	1500 psig (100 bar)
Maximum Loading Pressure	1500 psig (100 bar)
Maximum Outlet Pressure	1500 psig (100 bar)
Maximum Emergency Sensing Pressure	1000 psig (70 bar)
Maximum SpringHousing Pressure	1000 psig (70 bar)
Set Pressure Range	3-900 psig (0.2 - 62 bar) <sup>(2)</sup>

Table 3

<sup>(2)</sup> Refer to Table 4 for specific spring ranges.

Specifications			
Series	Spring Range	Color	Part Number
20 & 20S	3 - 12 psi (0.2 - 0.8 bar)	Red	040-014-01
	10 - 40 psi (0.7 - 2.7 bar)	Plated	040-011-01
	25 - 90 psi (1.7 - 6.2 bar)	Blue	040-012-01
	60 - 200 psi (4 - 14 bar)	Purple	040-008-01
	100 - 260 psi (7 - 18 bar)	Black <sup>(3)</sup>	040-009-01
	200 - 450 psi (14 - 31 bar)	Green <sup>(3)</sup>	040-020-01
20H & 20HS	200 - 520 psi (14 - 36 bar)	Black <sup>(3)</sup>	040-009-01
	400 - 900 psi (27 - 62 bar)	Green <sup>(3)</sup>	040-020-01

Table 4

<sup>(3)</sup> Spacer on Adjustment Screw Required

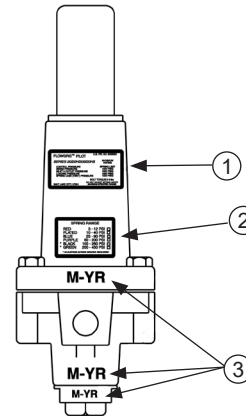

Figure 2

## Pilot Markings

(Refer to Figure 2)

1. Location of the Pilot nameplate.
2. Location of spring range nameplate. The factory marks the nameplate to indicate which spring is installed at manufacture date. If the spring is changed make sure to note it on the nameplate.
3. The month and year the pilot is manufactured is noted on the Spring Case, Body, and Body Insert of the pilot.

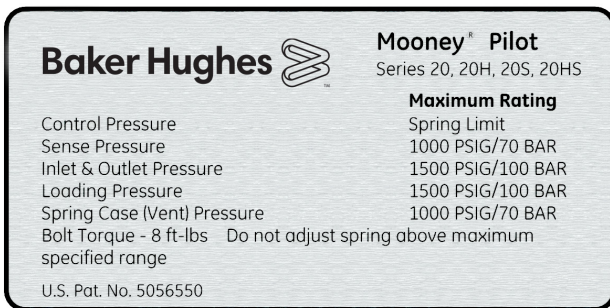

Figure 3

Nameplate for Series 20, 20H, 20S, & 20HS Mooney Pilots

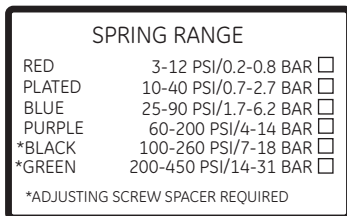

Figure 4

Spring Range Nameplate for Series 20 & 20S Mooney Pilots

Item	Definition
<b>Mooney Pilot</b>	Trademarked name of pilot.
<b>Series</b>	Model number of pilot.
<b>Control Pressure</b>	The control pressure is limited to the spring range of the spring on the pilot(Refer to Fig. 4 for Series 20 & 20S pilots)
<b>Sense Pressure</b>	Maximum allowable pressure in sense
<b>Inlet &amp; Outlet Pressure</b>	Maximum allowable pressure (psig) to the Inlet and Outlet ports.
<b>Loading Pressure</b>	Maximum allowable pressure (psig) to the Loading port.
<b>Spring Case (Vent) Pressure</b>	Maximum allowable pressure (psig) to the Spring Case (Vent) port.
<b>Bolt Torque</b>	Recommended bolt torque for spring case in foot pounds.
<b>Red, Plated, Blue, Purple, Black and Green</b>	Each spring is color coded to indicate the control pressure range
<b>Adjusting Screw Spacer</b>	The black and green springs require a spacer on the adjusting screw to avoid over compression.



Figure 5

Spring Range Nameplate for Series 20H & 20HS Mooney Pilots

# Series 20 Pilot – Piping Schematics - Unloading and Loading Type Valves

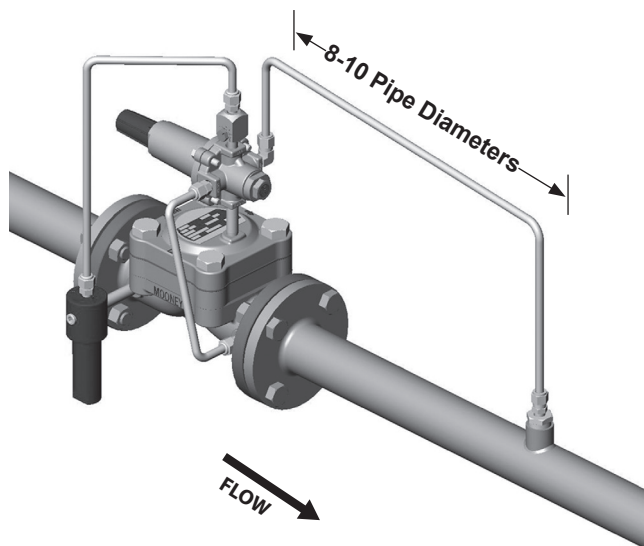

Figure 6

Unloading Type Valve (Pressure Reducing Valve)

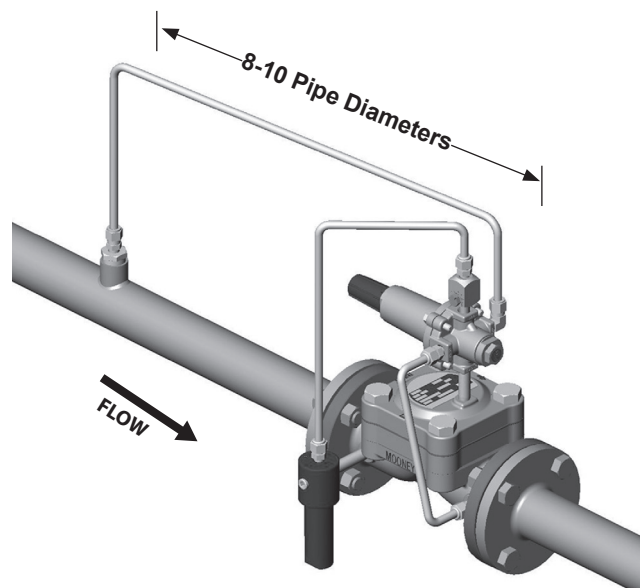

Figure 7

Unloading Type Valve (Back Pressure Valve)

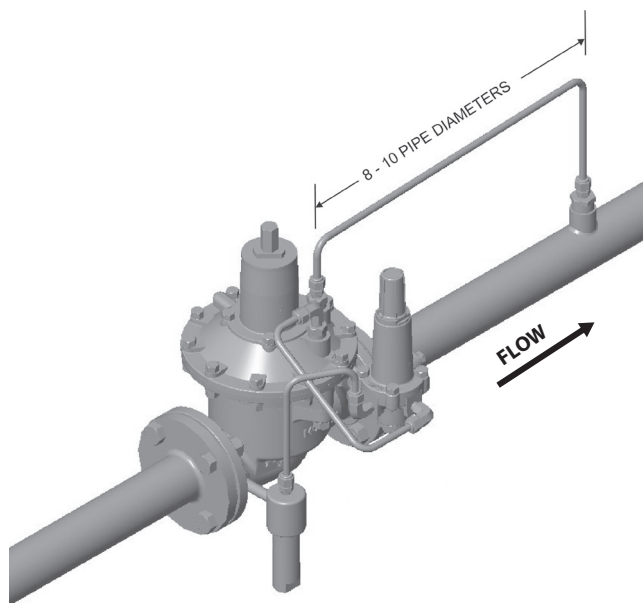

Figure 8

Loading Type Valve (Pressure Reducing Valve)

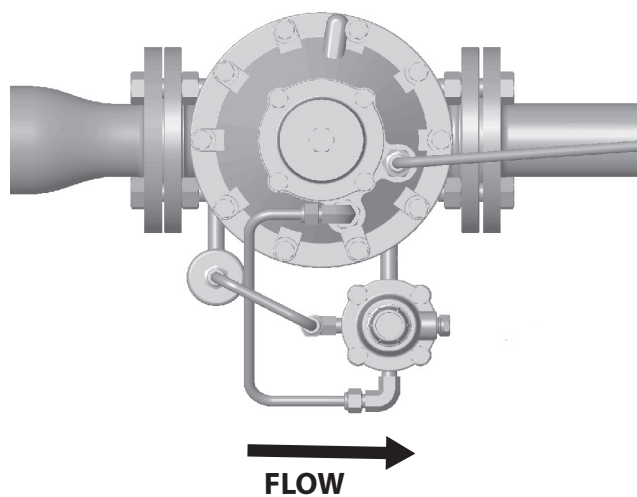

Figure 9

Typical Top View



## Series 20 Pilot – Unloading and Loading Type Valve Installation

### **WARNING**

Personal injury, equipment damage, leakage or explosion of accumulated gas or bursting of pressure containing parts may result if this valve/ regulator is overpressured or is installed where service conditions could exceed the limits given in the specification of this manual or on the nameplate, or where conditions exceed any ratings of the adjacent piping or piping connections. Verify the limitations of valve, pilot and pipeline to ensure no device is overpressured. To avoid such injury or damage, provide pressure relieving or pressure limiting devices (as required by the U.S. code of Federal Regulations, by the National Fire Codes of the National Fire Protection Association, or by other applicable codes) to prevent service conditions from exceeding those limits. Additionally, physical damage to the regulator, pilot, or tubing can cause personal injury and/or property damage due to explosion of accumulated gas. To avoid injury and damage, install the valve in a safe location.

### **WARNING**

Gas regulators installed in confined or enclosed spaces should be provided with adequate ventilation to prevent the possibility of gas buildup or accumulation from leaks and venting. Leaks or vented gas may accumulate causing personal injury, death, or property damage. Pilot spring cases and the regulator enclosure should be vented to a safe area away from air intakes, or any hazardous location. The vent lines and stacks must be protected against condensation and plugging.

**Note:** For Series 20 pilots, lubricate the adjusting screw with a light, nitrile rubber compatible grease such as Lubriplate #105, or equivalent, at first opportunity, and thereafter, annually and during any interim maintenance.

For Series 20 or 20H pilots (brass), inspect the closing cap for thread wear by verifying the torque required to modify the set point is less than 6 ft-lbs (8.14 Nm) and inspect for metal particles on the adjusting screw or on the closing cap threads. This should be completed at the first opportunity, and thereafter, annually and during any interim maintenance.

The Series 20 pilot with Purple, Black, or White with a Green Stripe have higher tendency to wear due to higher spring pressure. Spring range (color) is indicated on the spring range label located on the pilot.

If it is determined that closing cap thread wear has occurred, it is recommended that the cap and adjusting screw be replaced with a Closing Cap Assembly. For Closing Cap Assembly retro-fit kits, contact your local sales representative for ordering information.

1. **PERSONNEL:** Installation of the Series 20 Pilot on the Flowgrid Valve or any other manufacture's valve should be made by qualified personnel familiar with high-pressure piping and Pilot-operated Regulators.
  2. **PRIOR INSPECTION:** Inspect the Pilot for any damage that might have occurred in shipping.
  3. **CONTROL ACTION:** Inspect to make sure the Body Insert Assembly (Cartridge) is in the correct operational mode. Remove the Body Insert Assembly and measure the stem extension from the Body Insert. (Refer to the Maintenance section of this manual - Figure 18 & Figure 20, page 10.)
    - Pressure Reducing Mode (PRV): the stem extends 0.32 inches (8.12 mm).
    - Back Pressure Mode (BPV): the stem extends 0.45 inches (11.43 mm).If incorrect, follow the Body Insert Assembly disassembly and assembly instructions in the Maintenance section of this manual.
  4. **ORIENTATION:** The Series 20 Pilot may be installed in any position - the best position being one that provides easiest access for pilot adjustment and valve maintenance.
  5. **PILOT MOUNTING:** Apply pipe dope (thread lubricant/sealing compound) to a short (1-1/2 inch long) 1/4 inch NPT Schedule 80 seamless pipe nipple. For a Mooney Flowgrid the pilot is mounted by connecting the pilot LOADING port to the Mooney Flowgrid spring case loading port. For a Mooney FlowMax the pilot is mounted by connecting the pilot OUTLET port to the Mooney FlowMax actuator loading port. When mounting the Mooney Flowgrid valve it is best if the pilot OUTLET connection is on the same side as the 1/4-inch NPT connections on the valve body. (Refer to the Piping Schematics Page 6).
- Note:** To avoid galling when stainless steel to stainless steel connections are made, use a lubricant (such as NEVER SEEZ® by Bostik). For best results Lightly lubricate the female threads. Mixing the lubricant with pipe dope is also acceptable. When tightening do not exceed more than 1/4 turn past the point the threads start to bind.
6. **RESTRICTOR:** Mount a rotary scratch type restricting valve (such as the Type 24 Restrictor) to the Inlet port on the Mooney Pilot. (Refer to Piping Schematics Page 6)
  7. **PILOT SUPPLY LINES:** Run a 3/8-inch tubing or 1/4-inch pipe supply line from the upstream piping or from the valve body connection on the inlet side of the valve to the pilot restrictor. The pilot supply connection should have a full and clean opening.
  8. **A FILTER** in the pilot supply line is recommended to remove dirt and other particulates that could affect the restrictor or variable orifice in the pilot. Refer to the Type 30 Filter I/O/M manual for installation instructions.

**Note: A shutoff valve is not required in the supply to the pilot, but if one is installed it should be a full opening type.**

9. **PILOT DISCHARGE UNLOADING TYPE VALVES ONLY:** Run 3/8 inch tubing or 1/4 inch pipe from the pilot OUTLET port to the downstream piping or to the connection provided on the outlet of the Mooney Flowgrid valve as shown in the Piping Schematics Section (Page 6).

Standby monitor note: To ensure full capacity of a standby Monitor regulator station, it is important that the pilot discharge of the upstream regulator be connected downstream of the station if the minimum pressure drop (across the entire station) is below 60 psig (4.14 bar).

10. **PILOT GAS HEATERS (OPTIONAL):** Pilot supply gas can be heated to prevent the formation of ice or hydrates in the pilot system. Pilot supply gas heaters should be connected after the pilot filter (if one is used).

11. **CONTROL LINES:** Control lines should be run from the SENSE Port of the Mooney Flowgrid or FlowMax Pilot mounted on the valve to a point 8 to 10 pipe diameters away from the valve or any other device in the pipeline that can cause turbulence (refer to Piping Schematics).

Use Table 5 as a guide for the ideal tubing to use. Reduce as necessary to connect to the pilot.

**Note: The control line connection should be 8-10 pipe diameters away from areas of turbulence (such as valves, reducers, and elbows) and should have a full opening into the pipe, free from burrs, drill peels, and weld slag. Shutoff valves are not required in the control line(s), but if installed, they should be of the full opening type. The control line connection should be in a section of pipe where the gas velocity is less than 100 ft/s (30m/s) for stability.**

12. **VENT VALVES AND GAUGE CONNECTIONS:** Troubleshooting recommendation. To aid in maintenance and troubleshooting, shut off and vent valves should be installed in tubing connections, and should be of the full open or ball style.

Pilot Regulator with:	2 - 5 psi (0.14 - 0.34 bar)	Greater than 5 psi (0.35 bar)
Static Sense Line (No Flow) <sup>1</sup>	1/2" Tubing	3/8" Tubing
Sense Linewith Flow <sup>2</sup>	1/2" Pipe	1/2" Tubing

**Table 5**

1. The Mooney Series 20 Pilot has a static sense line.
2. The Sense line of the Mooney FlowMax Actuator has flow.

## Maintenance

Pilot parts are subject to normal wear and must be inspected and replaced as necessary. The frequency of inspection and replacement of parts depends on severity of service conditions and/or the requirements of local, state, and federal regulations. Be certain that the name plates are updated to accurately indicate any field changes in equipment, materials, service conditions, or pressure settings.

**! WARNING**

**Before disassembly make sure the regulator and pilot have been isolated from the process by closing block valves on the inlet and outlet sides of the regulator. Safely release pressure and process fluid from the regulator body and pilot system. Failure to properly complete these steps may result in personal injury and property damage.**

1. After depressurizing the pilot and main valve unscrew and remove Body Insert Assembly.
2. Remove the Stem O-ring from the pilot body using a suitable tool and being careful not to scratch the O-ring Groove.



**Figure 10**

**A paper clip easily extracts the O-Ring out of the pilot body**

**Note: A spare Body Insert Assembly may be installed and the regulator returned to service if time is a factor. Make sure the Stem O-Ring is in place in the Pilot Body before installing the new Body Insert Assembly or, if removed, slip a new O-Ring over the Stem of the Body Insert Assembly prior to installing it in the Pilot Body.**

### Pilot Disassembly - All Series 20 pilots

1. Remove the Bottom Cap from the Body Insert and remove the internal parts. The Orifice Assembly can be easily pushed out of the Body Insert using a heavy paper clip or 0.045" (1.14mm) diameter wire. See Figure 11.

**Note: Do not scratch or damage the O-Ring sealing surface of the Body Insert.**

2. Inspect all parts for wear or damage. Replace as necessary.



3. Pilot Diaphragm: Release all Main Spring tension by unscrewing Adjusting Screw. Remove Closing Cap, Spring Follower, and Main Spring. Remove Spring Housing Cap Screws and remove Diaphragm Assembly. Disassemble Diaphragm Assembly and inspect Diaphragm. Replace if necessary.



**Figure 11**  
The orifice can be pushed out of the Body Insert (Cartridge) using a paper clip

## Pilot Assembly - Series 20 & 20S

(Refer to Page 10 for the Series 20H & 20 HS Assembly Instructions)

1. Diaphragm Assembly: Install the Pilot Diaphragm with convex side toward Diaphragm Plate and Main Spring (Refer to Figure 12). Tighten nut on the Diaphragm Retainer to approximately 5 to 6 ft-lbs (6.78 - 8.14 n-m) torque.

**Note: Overtightening will distort the Pilot Diaphragm.**

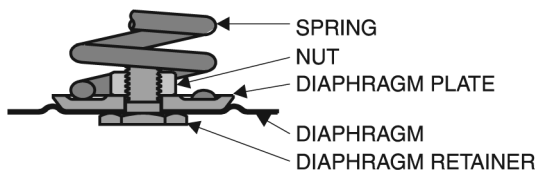

**Figure 12**

### Diaphragm Assembly for the Flowgrid Series 20 & 20S Pilot

2. Place Diaphragm Assembly in the pilot body with the diaphragm touching the grooved sealing surface of the pilot body. (Refer to Figure 13)



**Figure 13**  
Placing Diaphragm Assembly on Pilot Body

3. Place Spring Housing on Pilot Body with vent connection in desired position. It is recommended that the vent connection face down when the pilot is mounted on the regulator so that condensation will drain away instead of accumulating and possibly freezing.

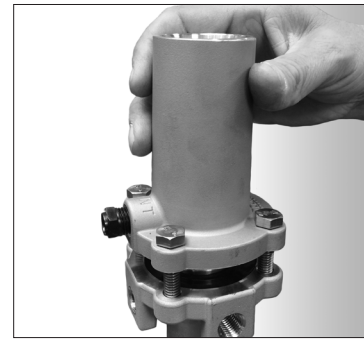

**Figure 14**  
Placing the Spring Housing on the Pilot Body

4. Install Spring Housing Cap Screws. Use cap screws supplied and tighten evenly to 8 ft-lbs (10.85 Nm) torque.
5. Install Spring and Spring Follower. Lubricate Spring Follower with a Petroleum Oil Grease such as Lubriplate No. 1051.
6. To avoid galling of adjusting screw, apply a small amount of lubricant (such as NEVER SEEZ® by Bostik) to the adjusting screw thread.

Lubricate with Petroleum Oil Grease such as LUBRIPLATE No. 105®



**Figure 15**  
Installing the Spring with lubricated Spring Follower

- 6A. **PILOTS WITH THE RED, PLATED, BLUE, AND PURPLE SPRINGS:** Install Closing Cap with Adjusting Screw and Sealing Nut and O-Ring.



**Figure 16**  
Installing the closing cap assembly for Pilot with the Red, Plated, Blue, and Purple Springs

6B. **PILOTS WITH BLACK AND GREEN SPRING:** Install Closing Cap with Adjusting Screw, Spacer, Sealing Nut, and O-Ring. The spacer prevents the Black and Green springs from being over compressed.



**Figure 17**

Installing the closing cap assembly with spacer (to prevent spring over compression) for Pilots with the Black and Green Springs

**Body Insert (Cartridge) Assembly - All Pilots  
Pressure Reducing (PRV) Mode**

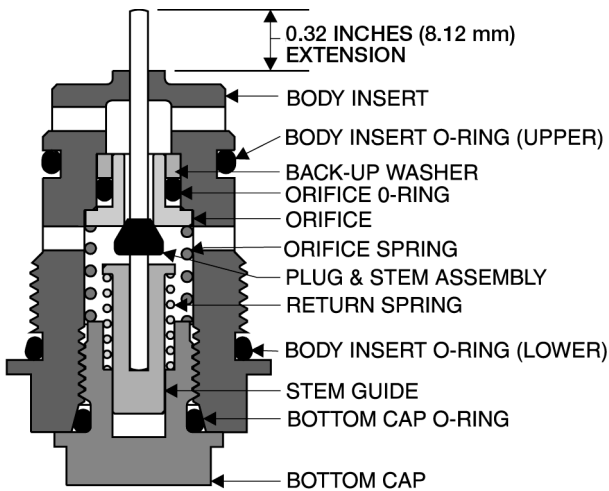

**Figure 18**

7A. Refer to Figure 18 & 19. Stack the following parts on the Bottom Cap in the order shown in the drawing:

- Return Spring
- Stem Guide
- Orifice Spring
- Plug and Stem
- Orifice
- Orifice O-Ring
- Back-up Washer

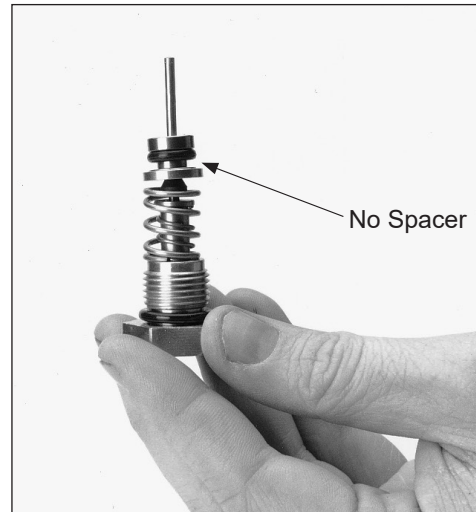

**Figure 19**

Stack the Return Spring, Stem Guide, Orifice Spring, Plug and Stem, Orifice, Orifice O-Ring, and Back-up Washer on the Bottom Cap

**Back Pressure or Relief (BPV) Mode**

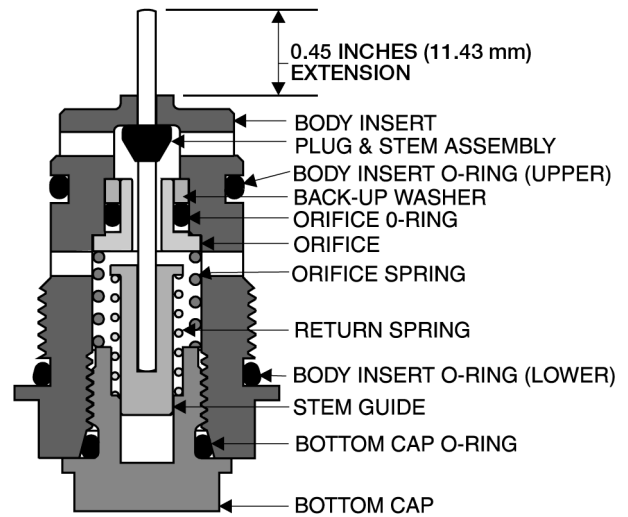

**Figure 20**

7B. Refer to Figure 20 & 21. Stack the following parts on the Bottom Cap in the order shown in the drawing:

- Return Spring
- Stem Guide
- Orifice Spring
- Orifice
- Orifice O-Ring
- Back-up Washer
- Plug and Stem

**Note:** The plug on the Stem will be ABOVE the Orifice Assembly for a Back Pressure or Relief Mode (Refer to Figure 20).

The plug will be BELOW the Orifice for the Pressure Reducing Mode (Refer to Figure 18).

The Orifice has a seating surface on both ends. The flange end of the Orifice must sit on the Orifice Spring.



**Figure 21**

**In the back pressure mode the Plug and Stem assembly is inverted**

8. Lubricate both Body Insert O-Rings with Parker O-Lube<sup>1</sup> (or equivalent Petroleum based Lubricant) and install on Body Insert (Cartridge).
9. Body Insert Assembly: Lift Bottom Cap complete with valve mechanism assembly and insert into Body Insert. The Orifice Spring should snap the Orifice into place as the Bottom Cap is screwed into place. Check the assembly by pushing the Stem against a hard surface to make sure it moves freely and returns to the extended position.

Measure the stem extension. (See Figure 18 & Figure 20)

Pressure Reducing mode: 0.32 inches (8.12 mm)

Back Pressure or Relief mode: 0.45 inches (11.43 mm)



**Figure 22**

**Insert the assembly into the Body Insert - the orifice should “snap” into place**

10. Lubricate Stem O-Ring with Parker Super-O-Lube® (or equivalent Silicon Lubricant) and slip over Stem.
11. Insert Body Insert into Pilot Body and screw into place snugly.

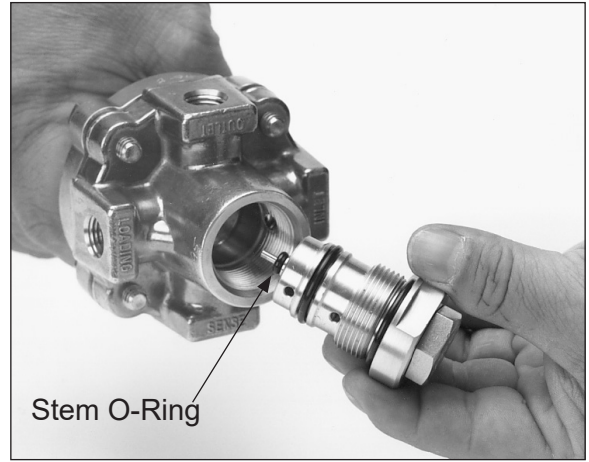

**Figure 23**

**Insert Body Insert (Cartridge) with lubricated Stem O-Ring into the Pilot Body**

**Note: Over tightening an O-Ring Joint will not improve the seal. Screw in until metal parts make contact and snug slightly.**

12. Pilot Assembly is now complete.

## Pilot Assembly - Series 20H & 20HS

**Note: The high pressure constructions (Series 20H & 20HS) differs from the Series 20 & 20S with the addition of a diaphragm spacer assembly that limits the effective area of the diaphragm and doubles the spring range of the black and green springs.**

1. Diaphragm Assembly: Install the Pilot Diaphragm with convex side toward Diaphragm Plate and Main Spring (Refer to Figure 24). Tighten nut on the Diaphragm Retainer to approximately 5 to 6 ft-lbs (6.78 - 8.14 n-m) torque.

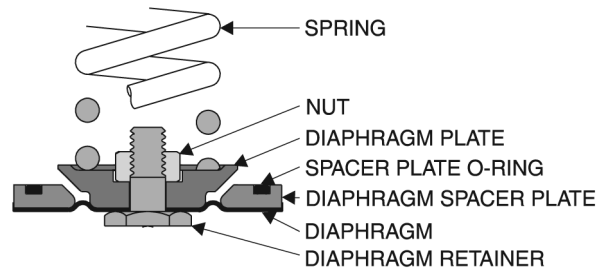

**Figure 24**

**Insert Body Insert (Cartridge) with lubricated Stem O-Ring into the Pilot Body**

**Note: Over tightening will distort the Pilot Diaphragm.**

2. Place Diaphragm Assembly in the pilot body with the diaphragm touching the grooved sealing surface of the pilot body and the O-Ring facing up. (Refer to Figure 24 & Figure 25).



**Figure 25**

**Placing high pressure Diaphragm Assembly on Pilot Body**

3. Place Spring Housing on Pilot Body with vent connection in desired position. The recommended position is with the vent connection facing down when the pilot is mounted on the regulator so that condensation will drain away instead of accumulating and possibly freezing. (Refer to Figure 14).
4. Install Spring Housing Cap Screws. Use Cap Screws supplied and tighten evenly to 8 ft-lbs torque.
5. Install Spring and Spring Follower.  
**Note: The Mooney Series 20H & 20HS use only the Black and Green Springs.**
6. Follow assembly directions for Series 20 & 20S Pilot for steps 6B through 10. Note the exception to Step 7 for the Series 20H & 20HS below.
7. The Series 20H and 20HS Pilots in back pressure mode require a Delrin orifice and all stainless steel plug and stem in the Body Insert (Cartridge). Assemble the orifice assembly the same way you would the Back Pressure Body Insert (Cartridge) with the stainless steel orifice and nitrile plug and stem assembly. (Refer to Figure 20 & Figure 26).

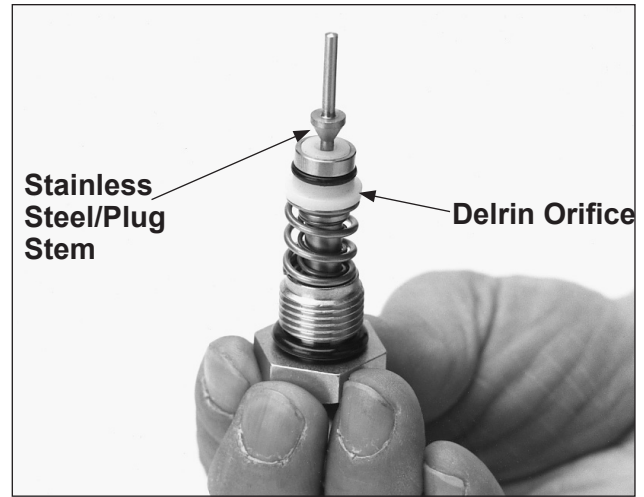

**Figure 26**

**The Series 20H & 20HS use a Delrin Orifice and Stainless Steel Plug/Stem assembly in the Back Pressure mode. The white Delrin material distinguishes itself from the standard stainless steel orifice.**

## Notes

# Notes



## Notes

# Find the nearest local Channel Partner in your area:

[valves.bakerhughes.com/contact-us](https://valves.bakerhughes.com/contact-us)

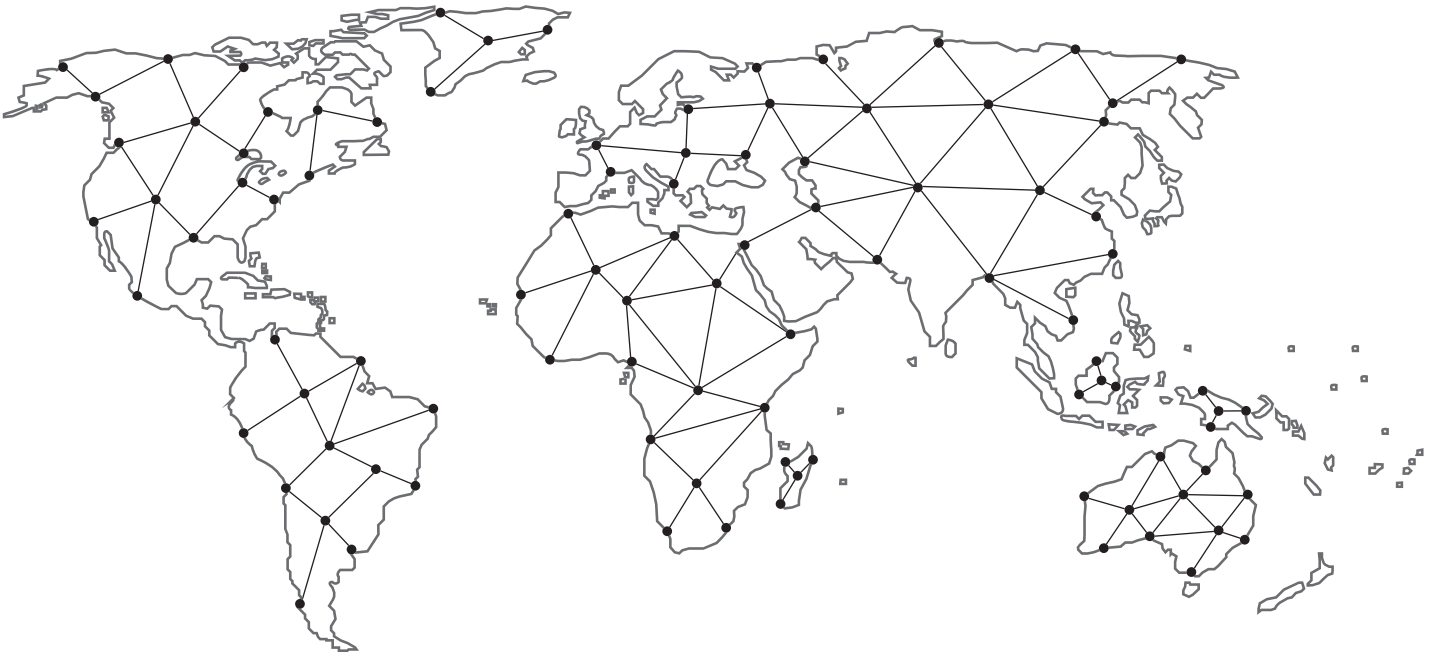

## Tech Field Support & Warranty:

Phone: +1-866-827-5378

[valvesupport@bakerhughes.com](mailto:valvesupport@bakerhughes.com)

[valves.bakerhughes.com](https://valves.bakerhughes.com)

Copyright 2023 Baker Hughes Company. All rights reserved. Baker Hughes provides this information on an "as is" basis for general information purposes. Baker Hughes does not make any representation as to the accuracy or completeness of the information and makes no warranties of any kind, specific, implied or oral, to the fullest extent permissible by law, including those of merchantability and fitness for a particular purpose or use. Baker Hughes hereby disclaims any and all liability for any direct, indirect, consequential or special damages, claims for lost profits, or third party claims arising from the use of the information, whether a claim is asserted in contract, tort, or otherwise. Baker Hughes reserves the right to make changes in specifications and features shown herein, or discontinue the product described at any time without notice or obligation. Contact your Baker Hughes representative for the most current information. The Baker Hughes logo and Mooney are trademarks of Baker Hughes Company. Other company names and product names used in this document are the registered trademarks or trademarks of their respective owners.

**Baker Hughes** 