

# PACE

## Pressure Automated Calibration Equipment SCPI Remote Communications Manual





# Introduction

This technical manual provides SCPI protocol instructions for the remote control of the PACE Series indicators and controllers.

## Safety

- The manufacturer has designed this product to be safe when operated using the procedures detailed in this manual. Do not use this product for any other purpose than that stated.
- This publication contains operating and safety instructions that must be followed to make sure of safe operation and to maintain the equipment in a safe condition. The safety instructions are either warnings or cautions issued to protect the user and the equipment from injury or damage.
- Use qualified<sup>1</sup> programming technicians and good engineering practice for all procedures in this publication.

## Pressure

Do not apply pressure greater than the maximum safe working pressure to the PACE Series.

## Maintenance

The PACE Series must be maintained using the manufacturer's procedures and should be carried out by authorized service agents or the manufacturer's service departments.

## Technical Advice

For technical advice contact the manufacturer or subsidiary.

## Associated Documents

A beginners Guide To SCPI by Barry Eppler, Published by Addison-Wesley Publishing Company Inc. for Hewlett Packard (ISBN 0-201-56350-9)

## Abbreviations

The following abbreviations are used in this manual; abbreviations are the same in the singular and plural.

Abbreviation	Description
a	Absolute
ALT	Altitude
ASCII	American Standard Code for Information Interchange
CAS	Calibrated Airspeed
e.g.	For example
ft	Foot
g	Gauge
GPIB	General Purpose Interface Bus
IDOS	Intelligent Digital Output Sensor (Druck product)
i.e.	That is

---

1. A programming technician must have the necessary specialist knowledge of programming, technical knowledge and documentation to carry out the required work on the PACE Series.

<b>Abbreviation</b>	<b>Description</b>
IEEE 488	Institute of Electrical and Electronic Engineers standard 488 (for programmable devices with a digital interface)
kg	kilogram
kts	knots
m	Metre
mA	Milliampere
max	Maximum
mbar	Millibar
min	Minute or minimum
mm	Millimetre
mV	Millivolts
MWP	Maximum Working Pressure
No	Number
PACE	Pressure Automated Calibration Equipment
PDCR	Pressure transducer
PED	Pressure Equipment Directive
PTX	Pressure transmitter
ROC	Rate of Climb
RS 232	Serial communications standard
Rt CAS	Rate of Calibrated Airspeed
Rt MACH	Rate of MACH
Rx	Receive data
SCPI	Standard Commands for Programmable Instruments
Tx	Transmit data
UUT	Unit Under Test
+ve	Positive
-ve	Negative
°C	Degrees Celsius
°F	Degrees Fahrenheit

## Pressure Measurement Units

The following units are used in this manual:

<b>Abbreviation</b>	<b>Description</b>
ATM	Atmosphere
BAR	bar
CMH2O	Centimetres of water at 20°C
CMHG	Centimetres of mercury

Abbreviation	Description
FTH2O	Feet of water at 20°C
FTH2O4	Feet of water at 4°C
HPA	Hecto Pascals
INH2O	Inches of water at 20°C
INH2O4	Inches of water at 4°C
INH2O60	Inches of water at 60°F
INHG	Inches of mercury
KG/CM2	Kilogrammes per square centimetre
KG/M2	Kilogrammes per square metre
KPA	Kilo Pascals
LB/FT2	Pounds per square foot
MH2O	Metres of water
MHG	Metres of mercury
MMH2O	Millimetres of water
MMHG	Millimetres of mercury
MPA	Mega Pascals
PA	Pascals
PSI	Pounds per square inch
TORR	Torr
MBAR	Millibar

## Code Definitions

The following codes are used in this manual:

Abbreviation	Description
ABOR	Abort
ADDR	Address
AVER	Average
ALT	Altitude
AMPL	Amplitude
ATOD	Analog to Digital
BAR	Barometer
BRID	Bridge
CAL	Calibration
CAT	Catalogue
CDIS	Cdisable (calibration disable)
CEN	Cenable (calibration enable)
CLS	Clear

<b>Abbreviation</b>	<b>Description</b>
COMM	Communicate
COMP	Compensate
COND	Condition
CONF	Configuration
CONT	Controller
CONV	Convert
CORR	Correction
COUN	Count
DEF	Define
DIAG	Diagnostic
DIOD	Diode
DISP	Display
EAV	Error in error queue
EFF	Effort
ENAB	Enable
EOI	End of input
ERR	Error
ESB	Summary bit from standard event
ESE	Event status enable
ESR	Event status register
EVEN	Event
FILT	Filter
FREQ	Frequency
FULL	Fullscale
GTL	Go to local
HEAD	Head
IDN	Identification
IMM	Immediate
INL	In limit
INP	Input
INST	Instrument
ISOL	Isolation
LEV	Level
LIM	Limit
LLO	Local lock out
LOG	Logical
LPAS	Low pass (filter)

<b>Abbreviation</b>	<b>Description</b>
MAV	Message available in output queue
MEAS	Measure
MSS	Summary bit after SRQ
NEGC	Negative Calibration
OFFS	Offset
OPC	Operational condition
OPER	Operation
OPT	Option
OSB	Summary bit from standard operations status register
OVER	Overshoot
OUTP	Output
PAR	Parity
PASS	Password
PERC	Percent
POIN	Points
PRES	Preset
PRES	Pressure
QUE	Queue
QUES	Questionable
RANG	Range
REF	Reference
RES	Resolution
RES	RESet
SAMP	Sample
SENS	Sense
SEPT	Set-point
SER	Serial
SOUR	Source
SPE	Speed
SRE	Service request enable
SRQ	Service request
STAR	Start
STB	Status register query
STAT	State
SYST	System
TIM	Time to set-point
UNIT	Unit of pressure

<b>Abbreviation</b>	<b>Description</b>
VAL	Value
VALV	Valve
VERS	Version
VOL	Volume



# Contents

1.	Introduction	1
1.1	General	1
1.2	System Model	1
1.3	Remote/Local Operation	1
2.	Command Structure	3
2.1	Notation	3
2.2	Message Terminators	3
2.2.1	Colon	3
2.2.2	Semicolon	3
2.2.3	Commas	3
2.3	Program Headers	4
2.3.1	Common Command and Query Headers	4
2.3.2	Instrument Control Command and Query Headers	4
2.3.3	Queries	5
2.4	SCPI Data Types	5
2.4.1	Decimal Data	5
2.4.2	Integer Data	5
2.4.3	Enumerated Character Data	6
2.4.4	Boolean Data	6
2.4.5	String Data	6
3.	Status System	7
3.1	Condition Register	7
3.1.1	Event Register	7
3.1.2	Enable Register	7
3.2	Output Queue	9
3.3	Standard Event Group	9
3.4	Operation Status Group	10
3.4.1	Vent Complete	10
3.4.2	Range Change Complete	10
3.4.3	In-Limits Reached	10
3.4.4	Zero Complete	10
3.4.5	Range Compare Alarm (PACE1000 only)	10
3.4.6	Auto Zero Started	11
3.4.7	Fill Timed Out	11
3.4.8	Switch Contacts Changed State	11
3.5	Status Byte Group	11
3.5.1	RS 232 Specific	12
3.5.2	IEEE 488 Specific	12
3.6	Instrument Errors	13
4.	Command and Query Summary	15
4.1	Command Structure	15
4.2	Command and Query Details	15
4.3	Dual Module Instruments	16
4.4	Commands	16
	CALibration	17

:CAL:PRES:POIN	19
:CAL:PRES:ACC	20
:CAL:PRES:ABOR	21
:CAL:PRES:VAL	22
:CAL:PRES:ZERO:VALV	24
:CAL:PRES:ZERO:REF	26
:CAL:PRES:ZERO:AUTO	27
:CAL:PRES:ZERO:TIME	28
:CAL:PRES:ZERO:TIME:STAT	29
DISPlay	31
:DISP:WIND	31
INPut	32
:INP:LOG	32
:INP:LOG:STAT	33
INSTrument	34
:INST:CAT:ALL	34
:INST:CAT	35
:INST:CONT:LIM	36
:INST:CONT:SENS	38
:INST:CONT:SENS:CALD	39
:INST:CONT:SENS:FULL	41
:INST:CONT:SENS:NEGC	42
:INST:CONT:SENS:SN	44
:INST:DISP	45
:INST:LIM	46
:INST:MAC	48
:INST:SENS	49
:INST:SENS:CALD	50
:INST:SENS:FULL	52
:INST:SENS:NEGC	54
:INST:SENS:READ	56
:INST:SENS:SN	57
:INST:SENS:ZERO	58
:INST:SN	59
:INST:TASK	61
:INST:TASK:AERO	62
:INST:TASK:LKT	63
:INST:TASK:SWT	65
:INST:UNIT	68
:INST:VERS	71
OUTPut	73
:OUTP:ISOL:STAT	73
:OUTP:LOG	74
:OUTP:LOG:LEV	76
:OUTP:MODE	78
:OUTP:STAT	79
SENSe	80
:SENS:AER	80
:SENS:ALT	81
:SENS:ALT:INL	82
:SENS:ALT:INL:TIME	83
:SENS:ALT:RANG	84
:SENS:ALT:SLEW	85

:SENS:AIRF:QFE	86
:SENS:AIRF:QFF	87
:SENS:AIRF:QNH	88
:SENS:MACH	89
:SENS:MACH:INL	90
:SENS:MACH:INL:TIME	91
:SENS:MACH:RANG	92
:SENS:MACH:SLEW	93
:SENS:PRES	94
:SENS:PRES:AVER	95
:SENS:PRES:AVER:RES	96
:SENS:PRES:AVER:TIME	97
:SENS:PRES:CONT	98
:SENS:PRES:INL	99
:SENS:PRES:INL:TIME	100
:SENS:PRES:SLEW	101
:SENS:PRES:BAR	102
:SENS:PRES:RANG	103
:SENS:PRES:RES	104
:SENS:PRES:CORR:HEAD	105
:SENS:PRES:CORR:HEAD:STAT	106
:SENS:PRES:CORR:OFFS	107
:SENS:PRES:CORR:OFFS:STAT	108
:SENS:PRES:CORR:VOL	109
:SENS:PRES:FILT:LPAS:BAND	110
:SENS:PRES:FILT:LPAS:FREQ	111
:SENS:PRES:FILT:LPAS:STAT	112
:SENS:PRES:MAX	113
:SENS:PRES:MAX:RES	114
:SENS:PRES:MIN	115
:SENS:PRES:MIN:RES	116
:SENS:PRES:PERC	117
:SENS:PRES:PERC:SPAN	118
:SENS:PRES:PERC:STAT	119
:SENS:PRES:PSE	120
:SENS:PRES:REF	121
:SENS:SPE	122
:SENS:SPE:INL	123
:SENS:SPE:INL:TIME	124
:SENS:SPE:RANG	125
:SENS:SPE:SLEW	126
SOURce	127
:SOUR:ALT	127
:SOUR:MACH:REF	128
:SOUR:MACH:REF:MODE	129
:SOUR:MACH:REF:VAL	130
:SOUR:MACH:LEV:IMM:AMPL	131
:SOUR:PRES:COMP	132
:SOUR:PRES:EFF	133
:SOUR:PRES:INL	134
:SOUR:PRES:INL:TIME	135
:SOUR:PRES:LEV:IMM:AMPL	136
:SOUR:PRES:LEV:IMM:AMPL:VENT	137

:SOUR:PRES:LEV:IMM:AMPL:VENT:RATE	139
:SOUR:PRES:LEV:IMM:AMPL:VENT:UNIT	140
:SOUR:PRES:RANG	141
:SOUR:PRES:RANG:LOW	142
:SOUR:PRES:SLEW	143
:SOUR:PRES:SLEW:MODE	145
:SOUR:PRES:SLEW:OVER:STAT	146
:SOUR:SPE:LEV:IMM:AMPL	147
:SOUR:SPE:SLEW	148
STATus	149
:STAT:OPER:COND	149
:STAT:OPER:ENAB	150
:STAT:OPER:EVEN	151
:STAT:OPER:PRES:COND	152
:STAT:OPER:PRES:ENAB	153
:STAT:OPER:PRES:EVEN	154
:STAT:PRES	156
:STAT:QUES:COND	157
:STAT:QUES:ENAB	158
:STAT:QUES:EVEN	159
SYSTem	160
:SYST:COMM:USB	160
:SYST:ERR	161
:SYST:DATE	162
:SYST:SET	163
:SYST:TIME	164
:SYST:COMM:SER:CONT:RTS	165
:SYST:COMM:SER:CONT:XONX	166
:SYST:COMM:SER:BAUD	167
:SYST:COMM:SER:TYPE:PAR	168
:SYST:COMM:GPIB:SELF:ADDR	169
:SYST:AREA	170
:SYST:PASS:CDIS	171
:SYST:PASS:CEN	172
:SYST:PASS:CEN:STAT	173
:SYST:VERS	174
UNIT	175
:UNIT:ALT	175
:UNIT:CONV	176
:UNIT:PRES	177
:UNIT:PRES:DEF	178
:UNIT:SPE	180
4.5 Common Commands	180
*CLS	181
*ESE	182
*ESR	183
*IDN?	184
*OPC	185
*SRE	186
*STB?	187
*TST?	188
*WAI	189
4.6 Instrument Control Commands	189

:GTL	190
:LLO	191
:LOC	192
:REM	193
:SRQ	194
:SRQ:ENAB	195
:SYN	196

<b>5. Errors</b>	<b>197</b>
5.1 Error Numbers	197



# Figures

Figure		Page
1-1	System Model	1
3-1	Status System	8





# Tables

<b>Table</b>		<b>Page</b>
2-1	Supported Multipliers	5
2-2	Binary, Octal and Hexadecimal Formats	6
3-1	Standard Event Register	9
3-2	Operation Status Register	10
3-3	Status Byte Register	12
4-1	Command Subsystem	15
5-1	Errors -100 to -199	197
5-2	Errors -200 to -299	198
5-3	Errors -300 to -399	198
5-4	Errors +201 to +212	198



# 1. Introduction

## 1.1 General

The IEEE 488 and RS 232 interfaces of the PACE Series provide remote control of the instrument from a suitable computer or controller. The SCPI protocol enables any instrument with a SCPI facility to be controlled using the same commands. The PACE Series use the full SCPI command set and the defined SCPI syntax.

The following sections describe and define each instrument command used by the PACE Series. The commands for the aeronautical option and the sensor calibration module option are described and defined in separate sections. Each section contains a quick reference structure of the relevant commands.

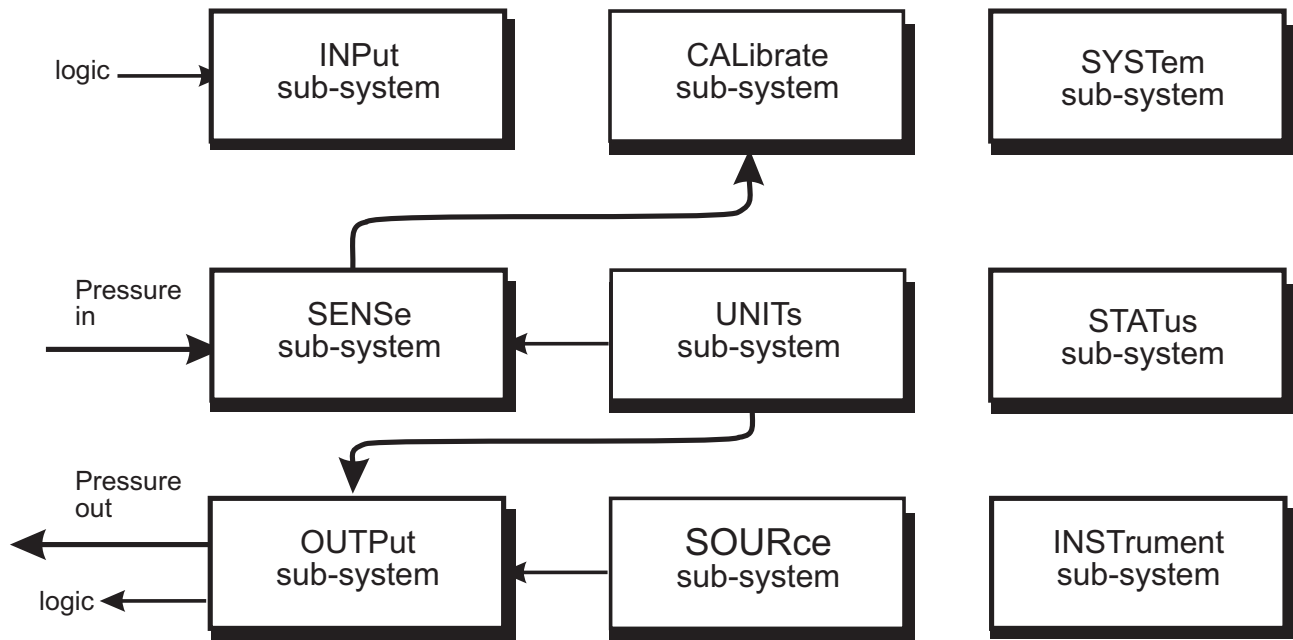

Figure 1-1: System Model

## 1.2 System Model

SCPI starts with a high-level block diagram of the measurement functions of the instrument. Each functional block is broken down into smaller block diagrams. SCPI contains a hierarchy of commands called a subsystem that maps directly to the hierarchy of the block diagram.

## 1.3 Remote/Local Operation

Most commands received over the SCPI interface automatically puts the PACE Series into remote control mode and disables the front panel touch-screen. Sending the LOC command returns the PACE Series to local control mode and enables the front panel touch-screen.



## 2. Command Structure

This section describes the structure of the commands and data sent and received by a PACE Series Controller/Calibrator.

### 2.1 Notation

All SCPI commands are based on a hierarchical tree structure consisting of key words and parameters. Associated commands are grouped together under a common node in the hierarchy.

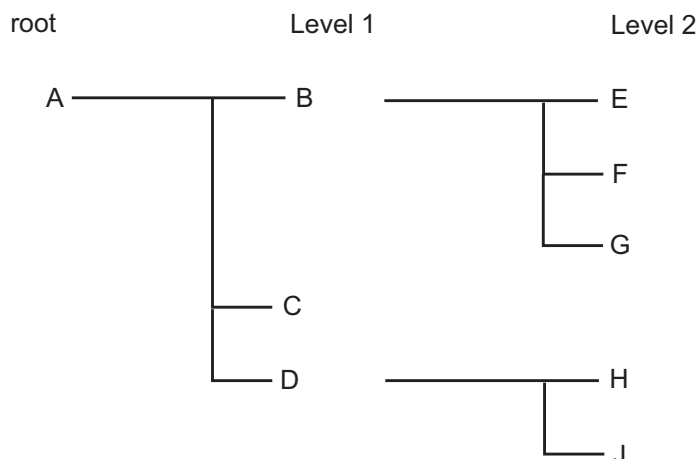

In the command tree the command A is the root command. A tree pointer is used to decode the SCPI commands. At power-up the pointer goes to the root command.

### 2.2 Message Terminators

All SCPI commands are terminated by line feed i.e., either <newline> (ASCII character, decimal 10), EOI for IEEE. After receiving a termination character the tree pointer returns to the root command.

#### 2.2.1 Colon

A colon moves the current path down one level in the command tree, (e.g., the colon in SOURCE:PRESSURE specifies PRESSURE the is one level below SOURCE). When the colon is the first character of the command, it specifies that the next command is a root level command (e.g., :SOURCE specifies that SOURCE is a root level command).

#### 2.2.2 Semicolon

A semicolon separates two commands in the same message without changing the tree pointer. e.g., with reference to the tree:

```
:A:B:E;F;G
```

This equivalent to sending three messages:

```
:A:B:E
```

```
:A:B:F
```

```
:A:B:G
```

#### 2.2.3 Commas

If a command requires more than one parameter, separate adjacent parameters by using a comma. A comma does not affect the tree pointer.

```
(e.g.): SYSTEM:TIME 10,25,30
```

To execute a command the full path to the command must be specified:

## Chapter 2. Command Structure

---

(e.g.): `OUTPut:STATe ON`

This turns the pressure controller on.

**Note:** There must be a space between the command words and the parameter. In the above example there is a space between: `STATe` and `ON`.

SCPI commands are not case sensitive and may have a short form.

(e.g.): `OUTP` is the short form of `OUTPUT`.

Some nodes can be the default node and these key words are optional when programming the command. The instrument processes the command, with the same effect, with or without the option node. In this manual [] enclose [default notes].

(e.g.): `SOURce[:PRESsure][:LEVel][:IMMediate][:AMPLitude] 5.0`

can be sent as

`:SOURce:PRESsure:LEVel 5.0`

or

`:SOURce 5.0`

This sets the set-point to 5.0

### 2.3 Program Headers

Program headers are keywords that identify a command, instruments accept both upper and lower case characters in a program header. There are two types of program header, common command headers and instrument control headers; each header can be a command or a query.

#### 2.3.1 Common Command and Query Headers

The common command and query program header syntax, specified in IEEE 488.2, are defined as follows:

Command

`*<PROGRAM MNEMONIC>`

Query

`*<PROGRAM MNEMONIC>?`

#### 2.3.2 Instrument Control Command and Query Headers

The instrument control command and query program header syntax controls and extracts data from the instrument as follows:

Command

`:<MNEMONIC>`

`:<MNEMONIC> <PARAMETER>`

Query

`:<MNEMONIC>?`

Instrument command headers can have a numeric suffix to identify each of several cases of the same header; the numeric suffix applies to both the long and short forms. All commands headers without a numeric suffix assume the value 1.

e.g.,

`:OUTPut:LOGic1?`

is the same as

`:OUTPut:LOGic:?`

### 2.3.3 Queries

A query is a program header with an attached question mark character (?). On receiving a query, the current settings are loaded in the output buffer. A query does not affect the operation or set-up of the instrument.

When the parameter of a command contains enumerated character data, both long form and short form are recognized. A query causes the return of data in the short form.

Querying numeric parameters causes the resulting data to be returned in the units selected by the instrument unless specified otherwise.

## 2.4 SCPI Data Types

A variety of data types can be sent to the instrument as parameters or sent out from the instrument as response data.

### 2.4.1 Decimal Data

All normal decimal expressions are accepted including optional signs, decimal point and scientific notation.

**Note:** This includes floating point data.

The following are valid:

- 123
- 45.67
- 2.6
- 4.6e-10
- .76

A suffix multiplier can be added to the numeric value.

:SOUR 100 m

would set the programmable output to 0.1 units (100m units).

The multipliers supported are:

**Table 2-1: Supported Multipliers**

Mnemonic	Multiplier
A	1e-18
G	1e+9
K	1e+3
M	1e-3
T	1e+12

If a real value is sent to the instrument when an integer is expected, it will be rounded to an integer.

### 2.4.2 Integer Data

Integer data are whole numbers (containing no decimal places). A query of an integer value returns numbers containing no decimal places.

## Chapter 2. Command Structure

---

**Note:** Integer values can be specified in binary, octal or hexadecimal formats using the suffix letters (upper or lower case) B, Q and H respectively.

**Table 2-2: Binary, Octal and Hexadecimal Formats**

Format	Description
#B1010	Binary representation of 10
#Q71	Octal representation of 57
#HFA <sup>a</sup>	Hexadecimal representation of 250

a. Hexadecimal digits A-F can be in upper or lower case.

### 2.4.3 Enumerated Character Data

Enumerated characters are used for data that has a finite number of values; enumerated parameters use mnemonics to represent each valid setting.

The mnemonics have long and short forms just like command mnemonics.

The following example selects the maximum rate mode:

```
:SOURce:PRESSure:SLEW:MODE MAXimum
```

A query of an enumerated parameter always returns the short form data in upper case.

Example:

```
:SOURce:PRESSure:SLEW:MODE?
```

Queries rate mode, reply:

```
:SOUR:PRES:SLEW:MODE MAX
```

### 2.4.4 Boolean Data

Boolean data can only be one of two conditions; the numbers 1 and 0. Boolean can be “on” or “off”, queries return 1 or 0.

Example:

```
:OUTPut:STATe 1
```

A query of boolean data always returns 1 or 0.

### 2.4.5 String Data

String data can only contain ASCII characters in the range of decimal 32 to 127. A string must start with a double “quote” (ASCII 34) or a single `quote` (ASCII 39) and end with the same character.

**Note:** Characters in a string in either double “quote” or single `quote` are case sensitive.

Example: 1:

```
:SOURCe[:PRESSure]:RANGe '2.00barg'
```

Example: 2:

```
:SOURCe[:PRESSure]:RANGe "2.00barg"
```

Selects the 2 bar g range.

A query of a string parameter always returns the string in double “quotes”.



## 3. Status System

The status reporting system informs the external controller that an event has occurred. This information is in the form of a service request (SRQ) using IEEE 488 or an SRQ message using RS 232.

The PACE Series uses status reporting as defined in IEEE 488.2 with the implementation of status registers.

The OPERATION status registers have been implemented to comply with the SCPI protocol. These are registers where the individual bits are summary bits of the status of the instrument. Since the SCPI protocol does not include pressure instruments, bit 10 of both these registers are used as a pressure summary bit. This pressure summary bit is expanded to two, 16 bit registers (Bit 15 is not used and is always zero).

The only bit implemented in the Operation status register is bit 10 (summary of the pressure operation status).

A summary bit is the final output of a data structure, it is a single bit that shows the status of one or more related events in the instrument. The basic structure of a summary bit:

- Condition register
- Event register
- Enable register
- Logical ANDing of the Event and Enable registers
- Summary bit that summarizes the result using OR logic

### 3.1 Condition Register

This register shows the current status of the device. The condition register is constantly updated - the bits in the register are set or reset showing the current condition.

#### 3.1.1 Event Register

The event register shows an event that occurs in the condition register (a condition bit goes from low to high). This condition change is stored and only reset when the event register is read or the \*CLS command sent.

#### 3.1.2 Enable Register

This register allows the results of the event register to pass through to the next cascaded register and enables the user to select the event that should generate the final SRQ event.

The status system implemented in the instrument is shown in the following diagram:

# Chapter 3. Status System

**Note:** Initial values of registers are 0, with the queues empty.

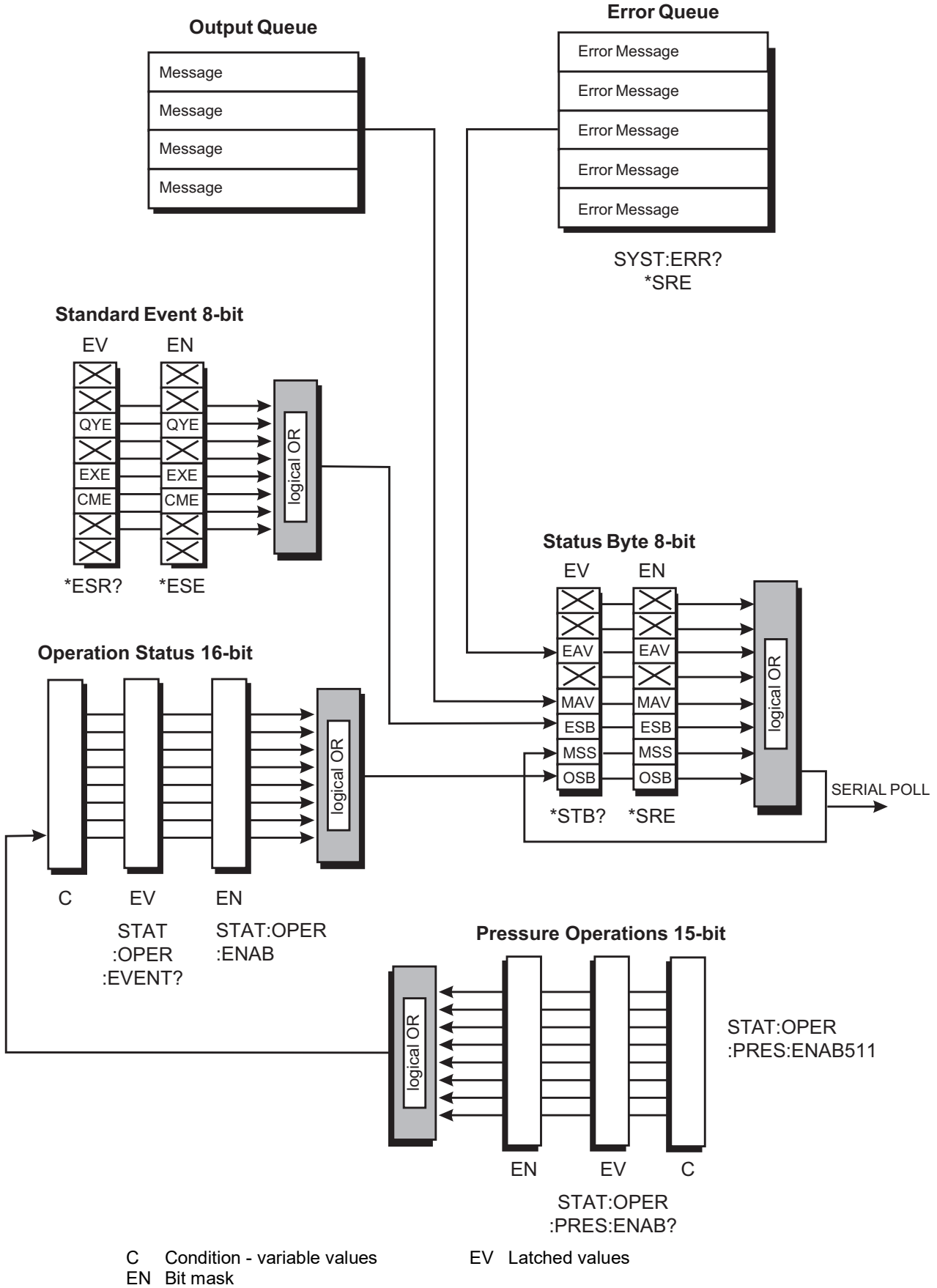

**Figure 3-1: Status System**

## 3.2 Output Queue

The output queue is a text readable data queue that is read through the IEEE 488 talk command. The queue is cleared by reading all elements in it or by the \*CLS command.

Every time a query has been successfully completed, the response, in a text readable format is placed at the end of the output queue. If the MAV bit in the "Status Byte" was previously cleared it will be set. The output queue can contain up to 256 characters. If there is not enough space in the output queue for a new message, the error -350, "Queue overflow" will be placed into the error queue and the most recent output message will be lost.

## 3.3 Standard Event Group

The standard event group are 8 bit registers that are read by the IEEE 488 standard commands. The event register is cleared by reading it; the event and enable registers are cleared by the \*CLS command.

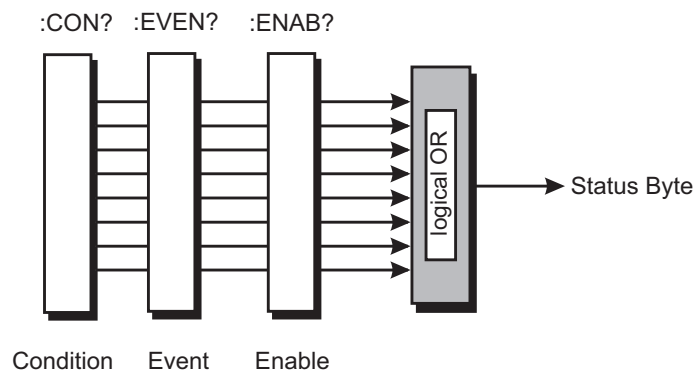

Bits within the standard event condition register are set by system errors and events. In addition to setting the status bits, a text message will be placed in the error queue. The ESB bit in the status byte sets if the associated bit in the event enable register is set. The enable register may be set through the \*ESE command so that selected standard events cause the ESB bit to be set. The system events that set each bit are as follows:

**Table 3-1: Standard Event Register**

Bit	Name	Description	Meaning/data
0	OPC	Not used	Reserved - returns 0
1	RQC	Not used	Reserved - returns 0
2	QYE	-400 to -499	Query errors
3	DDE	Not used	Reserved - returns 0
4	EXE	-200 to -299	Execution errors
5	CME	-100 to -199	Command errors
6	URQ	Not used	Reserved - returns 0
7	PON	Not used	Reserved - returns 0

### 3.4 Operation Status Group

The operation status group are 16 bit registers that are read by the STAT:OPER:PRES commands. The event register is cleared by reading it; the event and enable registers are cleared by the \*CLS command.

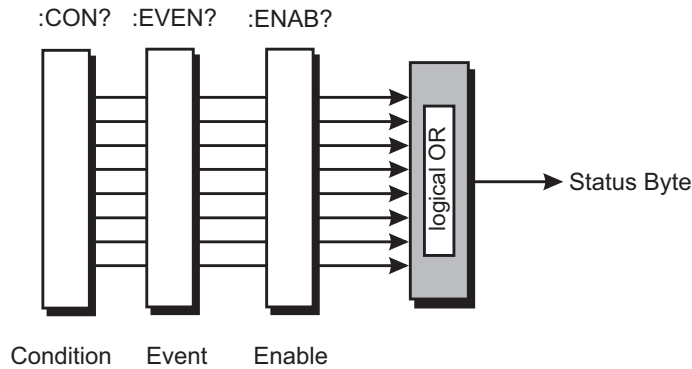

When a standard operation condition occurs an appropriate bit is set in the condition register (this clears when the condition no longer exists). The bit is then latched in the event register. If the associated bit in the enable register is set, the OPR bit in the status byte sets. The enable register may be set through the STAT:OPER:PRES:ENAB command so that only selected standard operation events cause the OPR bit to set.

Problems can occur with some IEEE 488 controllers reading 16 bit unsigned numbers. All registers in this group do not use bit 15. The enable bit cannot be set and when read returns 0. The condition register is defined as follows:

#### 3.4.1 Vent Complete

This signal occurs when the controller has been requested to vent and the vent has completed or timed out.

#### 3.4.2 Range Change Complete

This signal occurs when the controller has been requested to perform a range change and the range change is complete.

#### 3.4.3 In-Limits Reached

This signal is set every time the controlled pressure is within the specified limits. The signal is only generated if the pressure has been within limits for a user defined wait time period.

#### 3.4.4 Zero Complete

This signal is generated when a manual or timed zero is complete. If the zero times out then this signal is also generated.

#### 3.4.5 Range Compare Alarm (PACE1000 only)

This signal is generated when the range compare alarm is triggered during the range compare process.

**Table 3-2: Operation Status Register**

Bit (1)	Data (2)	Bit (3)	Data (4)
0	Vent complete	1	Range change complete
2	In-limits reached	3	Zero complete
4	Auto-zero started	5	Fill time, timed-out
6	Reserved - returns 0	7	Range compare alarm

**Table 3-2: Operation Status Register**

Bit (1)	Data (2)	Bit (3)	Data (4)
8	Switch contacts changed state	9	Reserved - returns 0
10	Reserved - returns 0	11	Reserved - returns 0
12	Reserved - returns 0	13	Reserved - returns 0
14	Reserved - returns 0	15	Reserved - returns 0

**3.4.6 Auto Zero Started**

When the controller is in the auto zero mode this signal indicates that the auto zero process has started. The zero complete signal indicates that the zero process has finished.

**3.4.7 Fill Timed Out**

Fill time out is not supported by PACE5000 or PACE6000. Refer instead to the 'INLimits' query.

**3.4.8 Switch Contacts Changed State**

Every time the switch contacts used for performing a switch test change state this bit is set.

**3.5 Status Byte Group**

The status byte group are 8 bit registers that are read by the IEEE 488 standard commands. The event register is cleared by reading it; the event and enable registers are cleared by the \*CLS command.

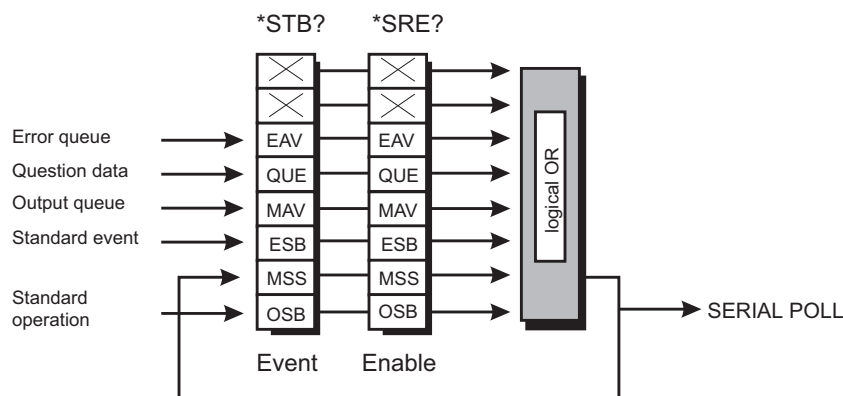

Bits within the status byte are a summary of other data structures in the status system. These bits will become set if other parts of the status system indicates that they should do so (i.e., a message in the output queue or error queue or, a condition and enable set in a register pair).

If the associated bit in the status enable register is set, a serial poll is generated and bit 6 is set. The enable register may be set through the \*SRE command so that only selected status bits cause a serial poll.

**Note:** Bit 6 of the enable register is always set to 0.

There are some small differences between \*STB? and serial polling. Either method can be used to read the state of bits 0-5 and bit 7. The reading method is different for bit 6 when using \*STB? and serial poll. In general, use serial polling inside interrupt service routines, not \*STB?

Bit 2 - EAV sets when there is an error in the error queue. The :SYST:ERR? command has to be sent to retrieve the error. The error queue buffers a maximum of five errors. When no more errors are available the message "No Error" is returned.

Bit 4 - MAV sets when there is a message available in the output queue.

Bit 5 - ESB sets when a standard event has occurred in the Standard Event Register.

## Chapter 3. Status System

---

Bit 6 - MSS sets when an SRQ is generated - SRQ sets when both the Status byte and the Service Request Enable register are at logic 1 (AND function).

### 3.5.1 RS 232 Specific

A service request (SRQ) produces the message:

:SRQ <value>

where:

<value> = the contents of the status summary byte.

The status system data structure sets each bit as follows:

**Table 3-3: Status Byte Register**

Bit	Name	Description
0	-	Reserved - returns 0
1	-	Reserved - returns 0
2	EAV	Error in error queue
3	-	Reserved - returns 0
4	MAV	Messages available in output queue
5	ESB	Summary bit from standard event
6	MSS	Summary bit after service request - SRQ
7	OSB	Summary bit from standard operations status

Example commands using the Status Byte and Status Byte Enable registers:

**\*SRE 16** Generate an SRQ interrupt when messages are available.

**\*SRE?** Find out what events are enabled to generate SRQ interrupts.

**\*STB?** Read and clear the Status Byte Enable register.

### 3.5.2 IEEE 488 Specific

Bit 7 - OSB sets when the pressure operations register bit 10 changes state. The operations register is a 16 bit register only using bit 10. This bit is a summary of the pressure operations register.

#### 3.5.2.1 Status Reporting Register Structure

To set-up the status reporting system.

1. All status registers should be cleared by the command:  
\*CLS
2. The Pressure Operations Event register has to be set to enable the Pressure Operations Condition Register to send all the events to be reported; use the command:  
:STAT:OPER:PRES:ENAB 511  
The enabled events may also be read by the query:  
:STAT:OPER:PRES:ENAB?
3. The Operation Status Event register must then be enabled to read bit 10 by the command:  
:STAT:OPER:ENAB 1024  
The enabled events may also be read by the query:  
:STAT:OPER:ENAB?

4. The status request to enable the SRQ must then be set.

To enable only the Operation Status register (OSB) send the command:

\*SRE 128

To enable the Operation Status register (OSB) and the Error Queue (EAV) send the command:

\*SRE 132

This register may also be read by the query:

\*SRE?

An event occurring generates an SRQ, the Status Byte should be queried to find the source of the event.

If bit 2 of the Status Byte Register is set the error queue can be read by the query:

:SYST:ERR?

Keep issuing this query until there are no more errors in the error queue. At this point, bit 2 of the Status Byte Register clears.

If bit 7 of the Status Byte Register is set the Pressure Operations event register can be read by the query:

:STAT:OPER:PRES?

returning the bits of events that have occurred. Reading this register clears it and the associated status bit (bit 7).

At any time the instantaneous status of the pressure system can be read by the query:

:STAT:OPER:PRES:COND?

### 3.6 Instrument Errors

Any instrument error that occurs, either programming errors or execution errors, is stored in an error queue which is separate from the main output queue. The errors can be read by issuing the following command query:

:SYST:ERR?

The error queue can hold up to five errors. Each time the error queue is queried the instrument responds with the next stored error in the queue. The response consists of an error number followed by a string describing the error. When the error queue is empty the instrument responds with:

:SYST:ERR 0, No error

Querying the error queue clears the storage location in the error buffer. If more than five errors occur, before being queried, the 'Queue overflow;Error queue overflow' message is placed into the error queue. All subsequent errors are lost until the error queue is cleared.





## 4. Command and Query Summary

The following lists of all the SCPI commands and queries that apply to the instrument.

### 4.1 Command Structure

Some of the commands in the following summary are enabled at specific times and conditions, most can be enabled at any time. The command structure divides into subsystems as follows:

**Table 4-1: Command Subsystem**

Command	Description
:CALibration	Calibration commands
:INPut	Switch input of the control module
:INSTrument	Instrument specific commands
:OUTPut	Controls the output pressure and logical outputs
:SENSe	Directs the instrument to measure selected parameters
:SOURce	The commands that control the pressure outputs
:STATus	Instrument state
:SYSTem	Errors and SCPI version
:UNIT	Sets the units for the instrument
Common SCPI Commands	Three letter commands, prefixed by '*'
Instrument Control Commands	Three letter commands, prefixed by ':'

### 4.2 Command and Query Details

This section describes each command in detail including parameters passed to it and response data returned. The general short form command is shown at the top of each page.

The following information is then given:

Applicability	A list of instruments that accepts and responds to the command or query.
<b>Command Syntax</b>	The upper case represents the short form command.
Parameter	Type: DECIMAL, INTEGER, ENUMERATED CHARACTER, BOOLEAN or STRING.
Short form	The short alternative for the command to be effective.
Function	Basic function of the command.
Default	The default value or the maximum and minimum values where appropriate.
<b>Query Syntax</b>	The upper case represents the short form command.
Parameter	Type: DECIMAL, INTEGER, ENUMERATED CHARACTER, BOOLEAN or STRING.
Short form	The short alternative for the command to be effective.
Function	Basic function of the command.
Response	Data returned by the instrument following the query command.
<b>Description</b>	Details of the command and query with any conditions of use and any related commands.

## Chapter 4. Command and Query Summary

---

**Note:** Many of the command descriptions contain an example code: sent (Tx) to the instrument and the data received (Rx) from the instrument.

### 4.3 Dual Module Instruments

Sending and receiving to a module must include either number 1 or 2 after the first part of the command or query. Without the module number, a dual module instrument defaults to module 1.

Long form example:

Tx> :SOURce2:PRESSure:EFFort?

Rx> :SOUR2:PRES:EFF -0.2342882

Short form example:

Tx> :SOUR2:PRES:EFF?

Rx> :SOUR2:PRES:EFF -0.2342882

### 4.4 Commands

## CALibration

The CALibration subsystem enables the calibration of the pressure transducers, zero valve open/close/status, pressure zero function and the timed zero function. A pressure range that is not displayed or is displayed can be calibrated. Refer to the user manual for further details. An example calibration process sample is shown below:

Tx	Rx	Remarks
:Inst:Cat1:All?	:INST:CAT:ALL "3.50barg","10.00barg","1.00bar g","BAROMETER","4.50bara"	Queries the catalogue of sensors fitted.
:SYST:ERR?	:SYST:ERR 0, No error	Queries the error queue, no errors.
:SOUR1:PRES:RANG?	:SOUR:PRES:RANG "4.50bara"	Queries for the currently selected displayed range.
:SENS1:PRES:RANG?	:SENS:PRES:RANG "3.50barg"	Queries for the currently selected SCPI range.
:SENS1:PRES?	:SENS:PRES -0.0004259	Pressure reading from the currently selected SCPI range ("3.50barg").
:SENS1:PRES:RANG "BAROMETER"	None	Selects the Barometer as the currently selected SCPI range for calibration.
:SENS1:PRES:RANG?	:SENS:PRES:RANG "BAROMETER"	Confirms the Barometer range is selected.
:SENS1:PRES?	:SENS:PRES 1005.7201013	Confirms the correct range is selected by reading the Barometer pressure output.
:SYST:ERR?	:SYST:ERR 0, No error	Queries the error queue, no errors.
:SYST:PASS:CEN:STAT?	:SYST:PASS:CEN:STAT 0	Queries for calibration mode status, calibration mode is disabled.
:SYST:PASS:CEN 2317100	None	Enables calibration mode.
:SYST:PASS:CEN:STAT?	:SYST:PASS:CEN:STAT 1	Confirms calibration mode is enabled.
:SENS1:PRES?	:SENS:PRES 1150.0000	Apply the calibration pressure and check the applied pressure is stable.
:CAL1:PRES:VAL1 1150.0000	None	Sends the 1 <sup>st</sup> calibration pressure of 1150.0000mbar.
:CAL1:PRES:VAL1?	:CAL:PRES:VAL 1150.0000000	Confirms the first calibration point pressure is received.
:SYST:ERR?	:SYST:ERR 0, No error	Queries the error queue, no errors.
:SENS1:PRES?	:SENS:PRES 750.0000	Apply the calibration pressure and check the applied pressure is stable.
:CAL1:PRES:VAL2 750.0000	None	Sends the 2 <sup>nd</sup> calibration pressure of 750.0000mbar.
:CAL1:PRES:VAL2?	:CAL:PRES:VAL 750.0000000	Confirms the 2 <sup>nd</sup> calibration point pressure is received.
:SYST:ERR?	:SYST:ERR 0, No error	Queries the error queue, no errors.

## Chapter 4. Command and Query Summary

---

<b>Tx</b>	<b>Rx</b>	<b>Remarks</b>
:CAL1:PRES:ACC 1	None	Accepts and implements the calibration.
:SYST:PASS:CEN:STAT?	:SYST:PASS:CEN:STAT 0	Calibration mode disabled.
:SYST:ERR?	:SYST:ERR 0, No error	Queries the error queue, no errors.

# :CAL:PRES:POIN

Applicability PACE1000, PACE5000, PACE6000

## Command Syntax

n/a

Parameter:

Short form:

Function:

Defaults:

## Query Syntax

### :CAL[x]:PRES:POIN?

where x = 1 = module 1 or x = 2 = module 2 (if x is blank the default is module 1).

Normal form: :CAL[x]:PRES:POIN?

Short form: :CAL[x]:POIN?

Function: Gets the number of calibration points

Response:

## Description

Valid only when calibration is enabled, this queries the number of calibration points. To enable calibration mode use the “:SYST:PASS:CED” command. To disable calibration mode use the “:SYST:PASS:CDIS” command. To query the current status of calibration mode use the “:SYST[x]:PASS:CEN:STAT?”. To check for systems errors use the “:SYST:ERR?” query.

x	Tx	Rx	Remarks
1	:CAL[x]:PRES:POIN?	:CAL1:PRES:POIN 3	
2	:CAL[x]2:PRES:POIN?	:CAL2:PRES:POIN 3	
	:SYST:ERR?	:SYST:ERR 0, No error	No errors, error queue empty.
	:SYST:ERR?	:SYST:ERR -203,"Access error; Incorrect password"	Calibration mode not enabled.

# **:CAL:PRES:ACC**

Applicability PACE1000, PACE5000, PACE6000

### **Command Syntax**

**:CALibration[x]:[PRESsure]:ACCept<space>[y]**

where x = 1 = module 1 or x = 2 = module 2 (if x is blank the default is module 1).

Parameter: y = Integer = 1 = accept, 0 = reject

Normal form :CAL[x]:PRES:ACC [y]

Short form: :CAL[x]:ACC [y]

Function: Accepts a calibration and exits calibration mode

Defaults: no default value

### **Query Syntax**

**n/a**

Short form:

Function:

Response:

### **Description**

Valid only when calibration is enabled, this command accepts the calibration after entry of the calibration values and measured pressure readings are now adjusted within a few seconds as the new calibration is implemented.

Gauge sensors normally require entry of three calibration values whereas absolute sensors normally require entry of only two calibration values.

To query calibration mode status, enable calibration mode and disable calibration mode refer to commands “:SYST:PASS:CEN:STAT”, “:SYST:PASS:CED” and “:SYST:PASS:CDIS”.

---

## **:CAL:PRES:ABOR**

Applicability            PACE1000, PACE5000, PACE6000

### **Command Syntax**

#### **:CALibration[x]:[PRESsure]:ABORt**

where x = 1 = module 1 or x = 2 = module 2 (if x is blank the default is module 1).

Parameter:            None  
Normal form            :CAL[x]:PRES:ABOR  
Short form:            :CAL[x]:ABOR  
Function:              Aborts calibration values  
Defaults:              no default value

### **Query Syntax**

**n/a**

Short form:  
Function:  
Response:

### **Description**

Aborts the current calibration and exits calibration mode. To query calibration mode status, enable calibration mode and disable calibration mode refer to commands:

“:SYST:PASS:CDIS”, “:SYST:PASS:CED” and “:SYST:PASS:CEN:STAT:”.

# :CAL:PRES:VAL

Applicability PACE1000, PACE5000, PACE6000

### Command Syntax

**:CALibration[x]:[PRESsure]:VALue[y]<space><value>**

where x = 1 = module 1 or x = 2 = module 2 (if x is blank the default is module 1) and y is the calibration data point.

Parameter: <decimal>

Normal form :CAL[x]:PRES:VAL[y] value

Short form: :CAL[x]:VAL[y] value

Function: Enables calibration value to be entered at each calibration point.

Defaults:

### Query Syntax

**:CAL[x]:PRES:VAL[y]?**

where x = 1 = module 1 or x = 2 = module 2 (if x is blank the default is module 1) and y is the calibration data point.

Normal form :CAL[x]:PRES:VAL[y]?

Short form: :CAL[x]:VAL[y]?

Function: Queries calibration point y value of module x.

Response: Returns pressure value for VALue[y] of module [x].

### Description

Valid only when calibration is enabled. This command enables a calibration value to be entered during the calibration process. The query gets the calibration value.

### Example:

Tx	Rx	Remarks
:CAL1:PRES:VAL1 -955.0000	None	1 <sup>st</sup> Calibration point and value.
:CAL1:PRES:VAL1?	:CAL:PRES:VAL -955.0000000	Confirms the value was entered correctly.
:CAL1:PRES:VAL2 -5.0000	None	2 <sup>nd</sup> Calibration point and value.
:CAL1:PRES:VAL2?	:CAL:PRES:VAL2-5.0000000	Confirms the value was entered correctly.
:CAL1:PRES:VAL3 245	None	3 <sup>rd</sup> Calibration point and value.
:CAL1:PRES:VAL3?	:CAL:PRES:VAL3 245.0000000	Incorrect value entered for calibration point 3.



Tx	Rx	Remarks
:CAL1:PRES:VAL3 2495.0000	None	Correct value entered for calibration point 3.
:CAL1:PRES:VAL3?	:CAL:PRES:VAL3 2495.0000000	Correct value entered for calibration point 3 validated.
:CAL1:PRES:ACC 1	None	Calibration accepted.

If a calibration point is entered incorrectly it can be re-entered assuming the correct applied pressure is still present. Once the calibration is accepted the point values entered adjust the calibration of the range selected for calibration.

Gauge sensors normally require entry of three calibration points whereas absolute sensors normally require entry of only two calibration points.

To query calibration mode status, enable calibration mode and disable calibration mode refer to commands “:SYST:PASS:CDIS”, “:SYST:PASS:CED” and “:SYST:PASS:CEN:STAT:”.

## :CAL:PRES:ZERO:VALV



**CAUTION** Opening the zero valve with high pressure in the system can cause the equipment to malfunction. Reduce the system pressure to zero gauge and make sure the controller is OFF before opening the zero valve.

Applicability            PACE5000, PACE6000

### Command Syntax

**:CALibration[x]:[PREssure]:ZERO:VALVe[STATe]**

where x = 1 = module 1 or x = 2 = module 2 (if x is blank the default is module 1)

- Parameter:            <boolean> 1 = open, 0 = close
- Normal form            :CAL[x]:PRES:ZERO:VALV <parameter>
- Short form:            :CAL[x]:ZERO:VALV <parameter>
- Function:              Opens and closes zero valve.
- Defaults:              0

### Query Syntax

**:CAL[x]:PRES:ZERO:VALV:STAT?**

where x = 1 = module 1 or x = 2 = module 2 (if x is blank the default is module 1)

- Normal form            :CAL[x]:PRES:ZERO:VALV:STAT?
- Short form:            :CAL[x]:ZERO:VALV?
- Function:              Queries state of valve.
- Response:             1 - valve is open  
                             0 - valve is close

### Description

This command is used to open and close the zero valve in each control module. The query gets the state of the zero valve, open or closed.

### Examples:

Module 1	Module 2	Function
TX> :CAL1:PRES:ZERO:VALV 1	:CAL2:PRES:ZERO:VALV 1	Opens the zero valve.
TX> :CAL1:PRES:ZERO:VALV:STAT 1	:CAL2:PRES:ZERO:VALV:STAT 1	Opens the zero valve.
Either of above two commands OPEN the module zero valve.		
TX> :CAL:PRES:ZERO:VALV:STAT?	:CAL2:PRES:ZERO:VALV:STAT?	Queries the current state of the valve.
RX> :CAL:PRES:ZERO:VALV:STAT 1	:CAL2:PRES:ZERO:VALV:STAT 1	Query reply = zero valve open.
TX> :CAL1:PRES:ZERO:VALV 0	:CAL2:PRES:ZERO:VALV 0	Closes the zero valve.
TX> :CAL1:PRES:ZERO:VALV:STAT 0	:CAL2:PRES:ZERO:VALV:STAT 0	Closes the zero valve.

Module 1	Module 2	Function
Either of above two commands CLOSE the module zero valve.		
TX> :CAL:PRES:ZERO:VALV:STAT?	:CAL2:PRES:ZERO:VALV:STAT?	Queries the current state of the valve.
RX> :CAL:PRES:ZERO:VALV:STAT 0	:CAL2:PRES:ZERO:VALV:STAT 0	Query reply = zero valve closed.

# **:CAL:PRES:ZERO:REF**

Applicability PACE5000, PACE6000

### **Command Syntax**

#### **:CALibration[x]:PRESsure:ZERO:REFerence**

where x = 1 = module 1 or x = 2 = module 2 (if x is blank the default is module 1)

Normal form :CAL[x]:PRES:ZERO:REF

Function: Pressure zeroing the reference sensor.

### **Query Syntax**

#### **:CALibration[x]:PRESsure:ZERO:REFerence?**

where x = 1 = module 1 or x = 2 = module 2 (if x is blank the default is module 1)

Normal form :CAL[x]:PRES:ZERO:REF?

Function: Query progress of the zeroing of the reference sensor.

### **Description**

This command starts or aborts the reference sensor zero process. The progress of the zero can be monitored by using the query.

### **Examples:**

TX> :CAL:PRES:ZERO:REF?	Queries the reference sensor zero status
RX> :CAL:PRES:ZERO:REF 0	Reference sensor zero status is complete or not in progress
TX> :CAL:PRES:ZERO:REF 1	Initiates reference sensor zero process
TX> :CAL:PRES:ZERO:REF?	Queries the reference sensor zero status
RX> :CAL:PRES:ZERO:REF 1	Reference sensor zero process is in progress

## :CAL:PRES:ZERO:AUTO

Applicability PACE1000, PACE5000, PACE6000

### Command Syntax

**:CALibration[x]:[PRESsure]:ZERO:AUTO<space><parameter>**

where x = 1 = module 1 or x = 2 = module 2 (if x is blank the default is module 1)

Parameter: <boolean>

0 - deactivates a zero process

1 - activates a zero process

Normal form :CAL[x]:PRES:ZERO:AUTO <parameter>

Short form: :CAL[x]:ZERO:AUTO <parameter>

Function: Automatic pressure zeroing

Defaults: 0

### Query Syntax

**:CAL[x]:PRES:ZERO:AUTO?**

where x = 1 = module 1 or x = 2 = module 2 (if x is blank the default is module 1)

Normal form :CAL[x]:PRES:ZERO:AUTO?

Short form: :CAL[x]:ZERO:AUTO?

Function: Query progress of zero

Response: 0 - Zero complete or not in progress.

1 - Zero in progress.

### Description

This command starts or aborts a zero process. The progress of the zero can be monitored by using the query.

### Examples:

TX> :CAL1:PRES:ZERO:AUTO?	Queries the zero status
RX> :CAL:PRES:ZERO:AUTO 0	Zero status is complete or not in progress
TX> :CAL:PRES:ZERO:AUTO 1	Initiates an auto-zero process
TX> :CAL1:PRES:ZERO:AUTO?	Queries the zero status
RX> :CAL:PRES:ZERO:AUTO 1	An auto-zero process is in progress

# :CAL:PRES:ZERO:TIME

Applicability PACE5000, PACE6000

### Command Syntax

**:CALibration[x]:[PRESsure]:ZERO:TIME<space><parameter>**

where x = 1 = module 1 or x = 2 = module 2 (if x is blank the default is module 1)

Parameter: Numeric, time value in hours.

Normal form :CAL[x]:PRES:ZERO:TIME <parameter>

Short form: :CAL[x]:ZERO:TIME <parameter>

Function: Sets time period in hours between zero events.

Defaults: -

### Query Syntax

**:CAL[x]:PRES:ZERO:TIME?**

where x = 1 = module 1 or x = 2 = module 2 (if x is blank the default is module 1)

Normal form :CAL[x]:PRES:ZERO:TIME?

Short form: :CAL[x]:ZERO:TIME?

Function: Queries timed zero.

Response: Integer number in hours.

### Description

This command sets the time interval between timed zeroing. Queries the current setting and sends a new setting in hours. If the current setting is less than 1hour the query returns 0. Only available in basic task.

### Examples:

Tx	Rx	Remarks
:CAL:ZERO:TIME?	:CAL:PRES:ZERO:TIME 0	Queries Module 1 zero time interval = 0
:CAL:ZERO:TIME 3	None	Sets module 1 zero time interval to 3 hours.
:CAL:ZERO:TIME?	:CAL:PRES:ZERO:TIME 3	Queries Module 1 zero time interval = 3
:CAL2:ZERO:TIME?	:CAL:PRES:ZERO:TIME 0	Queries Module 2 zero time interval = 0
:CAL2:ZERO:TIME 2	None	Sets module 2 zero time interval to 2 hours.
:CAL2:ZERO:TIME?	:CAL:PRES:ZERO:TIME 2	Queries Module 2 zero time interval = 2

## :CAL:PRES:ZERO:TIME:STAT

Applicability PACE5000, PACE6000

### Command Syntax

**:CALibration[x]:[PRESsure]:ZERO:TIME:STATe<space><parameter>**

where x = 1 = module 1 or x = 2 = module 2 (if x is blank the default is module 1)

Parameter: <<boolean>>

Normal form :CAL[x]:PRES:ZERO:TIME:STAT 1

Short form: :CAL[x]:ZERO:TIME:STAT 1

Function: Sets timed zero on/off.

Defaults: 0  
(0 - sets timed zero to OFF)  
(1 - sets timed zero to ON)

### Query Syntax

**:CALibration[x]:[PRESsure]:ZERO:TIME:STATe?**

where x = 1 = module 1 or x = 2 = module 2 (if x is blank the default is module 1)

Normal form :CAL[x]:PRES:ZERO:TIME:STAT?

Short form: :CAL[x]:ZERO:TIME:STAT?

Function: Queries the status of the timed zero ON or OFF.

### Description

This command sets the time period for zero on or off. This query gets the status of the timedzero (on or off)

### Examples:

Tx	Rx	Remarks
:CAL:PRES:ZERO:TIME:STAT?	:CAL:PRES:ZERO:TIME:STAT 0	Queries Module 1 timed zero status.
:CAL:PRES:ZERO:TIME:STAT 1	None	Activates module 1 timed zero mode.
:CAL1:PRES:ZERO:TIME:STAT?	:CAL:PRES:ZERO:TIME:STAT 1	Queries Module 1 timed zero status.
:CAL1:PRES:ZERO:TIME:STAT 0	None	Deactivates module 1 timed zero mode.
:CAL:PRES:ZERO:TIME:STAT?	:CAL:PRES:ZERO:TIME:STAT 0	Queries Module 1 timed zero status.
:CAL2:PRES:ZERO:TIME:STAT?	:CAL2:PRES:ZERO:TIME:STAT 0	Queries Module 2 timed zero status.
:CAL2:PRES:ZERO:TIME:STAT 1	None	Activates module 2 timed zero mode.

## Chapter 4. Command and Query Summary

---

<b>Tx</b>	<b>Rx</b>	<b>Remarks</b>
:CAL2:PRES:ZERO:TIME:STAT?	:CAL2:PRES:ZERO:TIME:STAT 1	Queries Module 2 timed zero status.
:CAL2:PRES:ZERO:TIME:STAT 0	None	Deactivates module 2 timed zero mode.
:CAL2:PRES:ZERO:TIME:STAT?	:CAL2:PRES:ZERO:TIME:STAT 0	Queries Module 2 timed zero status.

---



---

## DISPlay

The DISPlay subsystem shows the state of the display window.

### :DISP:WIND

Applicability      PACE1000

#### Command Syntax

**n/a**

Parameter:

Short form:

Function:

Defaults:

#### Query Syntax

### :DISP[x]:WIND?

where: x is the window index 1 to 3. Index 1 is the top window, index 2 is the middle status area window and index 3 is the lower function area window.

Short form:            :DISP[x]:WIND?

Function:              Asks for window for an allocated range

Response:              DISP 1, 2 or 3 and the value in the selected units.

#### Description

This query returns the measured reading from the selected display window.

#### Examples:

TX> :DISP1:WIND?

RX> :DISP:WIND "979.44"

TX> :DISP2:WIND?

RX> :DISP2:WIND "993.55"

# INPut

The INPut subsystem shows the state of the logical inputs.

## :INP:LOG

Applicability PACE1000, PACE5000, PACE6000

### Command Syntax

n/a

Parameter:

Short form:

Function:

Defaults:

### Query Syntax

#### :INPut[x]:LOGic?

where: x (module) = 1 or 2 (default - 1),

Short form: :INP:LOG?

Function: Asks for state of switch input within the controller module.

Response: first parameter - 0 = OFF, 1 = ON  
second parameter - measured pressure at the time of switching (snapshot in current pressure units).

### Description

This query returns the state of the switch input within the module and the pressure at time of switching operations.

### Example:

```
TX> :INP:LOG?
```

```
RX> :INP:LOG 0, 0.8321209
```

Current logic OFF, pressure was 0.8321209 in current pressure units when the module was switched to OFF condition.

---

## :INP:LOG:STAT

Applicability PACE1000, PACE5000, PACE6000  
**Note:** Only applies to the PACE1000 when the VFC option is fitted.

### Command Syntax

n/a

Parameter:

Short form:

Function:

Defaults:

### Query Syntax

**:INPut[x]:LOGic:STATe?**

where: x (module) = 1 or 2 (default - 1),

Short form: :INP:LOG:STAT?

Function: Asks for state of switch input.

Response: 0 = OFF, 1 = ON

### Description

This query returns the state of the switch input.

# INSTrument

The INSTrument subsystem gets information about the configuration of the instrument.

## :INST:CAT:ALL

Applicability      PACE1000, PACE5000, PACE6000

### Command Syntax

n/a

Parameter:

Short form:

Function:

Defaults:

### Query Syntax

## :INSTrument:CATalog[x]:[ALL]?

where: x (module) = 1 or 2 (default - 1)

Short form:      :INST:CAT[x]:ALL?

Function:      Query all ranges fitted, including source sensor ranges.

Response:      A list of comma separated strings  
of ranges fitted.

### Description

This query returns all the ranges fitted to the instrument. The reply is a comma separated list of strings representing each range.

### Example:

A dual module instrument with a 7.00 barg module and a 3.50 barg module. Both have a barometric option fitted.

```
TX> :INST:CAT1:ALL?
```

```
RX> :INST:CAT:ALL "3.50barg","10.00barg","1.00barg","BAROMETER","4.50bara"
```

```
TX> :INST:CAT2:ALL?
```

```
RX> :INST:CAT2:ALL "2.00barg","3.50barg","1.00barg","BAROMETER","3.00bara"
```

## :INST:CAT

Applicability PACE1000, PACE5000, PACE6000

### Command Syntax

n/a

Parameter:

Short form:

Function:

Defaults:

### Query Syntax

#### :INSTrument:CATalog[x]?

where: x (module) = 1 or 2 (default - 1)

Short form: :INST:CAT[x]?

Function: Query all ranges fitted, does not including source sensor ranges.

Response: A list of comma separated strings of ranges fitted.

### Description

This query returns all measure ranges fitted to the instrument. The reply is a comma separated list of strings representing each range.

### Example:

A dual module instrument with a 7.00 barg module and a 3.50 barg module. Both have a barometric option fitted.

```
TX> :INST:CAT1?
```

```
RX> :INST:CAT: "7.00barg","BAROMETER","8.00bara"
```

```
TX> :INST:CAT2?
```

```
RX> :INST:CAT2: "3.50barg","BAROMETER","4.50bara"
```

## :INST:CONT:LIM

Applicability PACE6000

### Command Syntax

n/a

Parameter:

Short form:

Function:

### Query Syntax

#### :INSTrument:CONTroller[x]:LIMits[y]?

Use the CONT index(x) to determine which control module 1 (or blank) or 2. Both :INST:CONT and :INST:CONT1 will address control module 1, whilst :INST:CONT2 addresses only control module 2.

Use the LIM index(y) to determine which sensor as below.

Short form: :INST:CONT:LIM?

Function: Queries the upper and lower full-scale limits of the fitted sensor ranges.

The index number x is used to index the control module.

The index number y is used to index into the list of available ranges.

Response: A string representing the range, a number representing the upper full-scale and a number representing the lower full-scale.

### Description

This query returns a string representing the range, a number representing the upper full-scale and lower full-scale.

x	y	PACE6000 Sensor
1 or blank	1	Module 1: control sensor
1 or blank	2	Module 1: source pressure +ve
1 or blank	3	Module 1: source pressure -ve
1 or blank	4	Module 1: barometric range (optional)
1 or blank	5	Module 1: CM3 reference sensor (if fitted)
1 or blank	6	Module 1: external IDOS sensor
1 or blank	7	Module 1: Pseudo Range based on the control sensor range
2	1	Module 2: control sensor
2	2	Module 2: source pressure +ve
2	3	Module 2: source pressure -ve
2	4	Module 2: barometric range (optional)

x	y	PACE6000 Sensor
2	5	Module 2: CM3 reference sensor (if fitted)
2	6	Module 2: external IDOS sensor
2	7	Module 2: Pseudo Range based on the control sensor range

**Example:**

A dual module instrument, both modules with the barometric option fitted.

```

TX> :INST:CONT:LIM?
RX> :INST:CONT:LIM "7.00barg", 7350.000000, -1100.000000
TX> :INST:CONT:LIM1?
RX> :INST:CONT:LIM "7.00barg", 7350.000000, -1100.000000
TX> :INST:CONT:LIM2?
RX> :INST:CONT:LIM2 "20.00barg", 21000.000000, -1100.000000
TX> :INST:CONT:LIM3?
RX> :INST:CONT:LIM3 "2.00barg", 2100.000000, -1100.000000
TX> :INST:CONT:LIM4?
RX> :INST:CONT:LIM4 "BAROMETER", 1207.500000, 825.000000
TX> :INST:CONT2:LIM5?
RX> :INST:CONT2:LIM5 "2.00bara", 2000.000000, 0.0
TX> :INST:CONT:LIM7?
RX> :INST:CONT:LIM7 "8.00bara", 8400.000000, 0.0

```

# :INST:CONT:SENS

Applicability PACE6000

### Command Syntax

n/a

Parameter:

Short form:

Function:

### Query Syntax

**:INSTrument:CONTroller[x]:SENSe[y]?**

Short form: :INST? or INST:CONT?

Use the CONT index(x) to determine which control module 1 (or blank) or 2. Both :INST:CONT and :INST:CONT1 will address control module 1, whilst :INST:CONT2 addresses only control module 2.

Use the SENS index(y) to determine which sensor as below.

### Description

This command returns the transducer range.

y	PACE6000 Sensor
1 or blank	Control sensor full-scale
2	+ve port source pressure sensor full-scale
3	-ve port vacuum pressure sensor full-scale
4	Barometer if fitted
5	Reference sensor range if fitted
6	External IDOS sensor
7	Pseudo absolute range

### Example:

TX> :INST:CONT1:SENS2?

RX> :INST:CONT1:SENS2 "7.00barg" 1<sup>st</sup> control module source pressure sensor

TX> :INST:CONT2:SENS4?

RX> :INST:CONT2:SENS4 "BAROMETER" 2<sup>nd</sup> control module barometric sensor

Refer to command :INST:SENS to address PACE5000 and PACE1000.



# :INST:CONT:SENS:CALD

Applicability PACE6000

## Command Syntax

n/a

Parameter:

Short form:

Function:

## Query Syntax

**:INSTrument:CONTroller:SENSor[x]:CALD[y]?**

where x (sensor number) = 1, 2...10 (default -1) y = 1, 2, 3...10 (y times last calibration date)

Short form: :INST:CONT:SENS:CALD?

Function: Queries sensor calibration dates in the form yyyy, mm, dd.

Response: Returns sensor [x] with [y] calibration date:

where:

x is the sensor number, x= 1, 2...10

is the y<sup>th</sup> calibration date for sensor x.

y = 1, 2, 3...10 calibration dates stored for each sensor.

## Description

This query returns the following:

x	PACE6000
1	Module 1: control sensor
2	Module 1: source pressure +ve
3	Module 1: source pressure -ve
4	Module 1: barometric sensor (optional)
5	Module 2: control sensor
6	Module 2: source pressure +ve
7	Module 2: source pressure -ve
8	Module 2: barometric sensor (optional)
9	Module 1: reference sensor
10	Module 2: reference sensor

## Example

TX> :INST:CONT:SENS5:CALD1?

RX> :INST:CONT:SENS5:CALD 2019, 11, 21

TX> :INST:CONT:SENS5:CALD2?

RX> :INST:CONT:SENS5:CALD2 2019, 11, 17

## Chapter 4. Command and Query Summary

---

This shows that the module 2 control sensor was last calibrated on 21<sup>st</sup> November 2019 and the previous calibration was on 17<sup>th</sup> November 2019.

**Note:** The default date is 01/01/2000, which means no previous calibration date is available or if the expected sensor matching that parameter is not fitted.

Check the indexes of the :INST:CONT:SENS:CALD command.

A pseudo-range does not return a calibration date.

# :INST:CONT:SENS:FULL

Applicability PACE6000

## Command Syntax

n/a

Parameter:

Short form:

Function:

## Query Syntax

### :INSTrument:CONTroller[x]:SENSor[y]:FULLscale?

Use the CONT index(x) to determine which control module 1 (or blank) or 2. Both :INST:CONT and :INST:CONT1 will address control module 1, whilst :INST:CONT2 addresses only control module 2.

where: y = 1, 2...7 is the sensor number. It defaults to 1.

Short form: :INST:CONT:SENS[y]:FULL?

Function: Queries sensor full-scale value.

Response: Returns the full-scale value of the selected sensor.

## Description

This query returns the full-scale value of the selected sensor.

x	y	PACE6000 Sensor
1 or blank	1	Module 1: control sensor
1 or blank	2	Module 1: source pressure +ve
1 or blank	3	Module 1: source pressure -ve
1 or blank	4	Module 1: barometric range (optional)
1 or blank	5	Module 1: CM3 reference sensor (if fitted)
1 or blank	6	Module 1: external IDOS sensor
1 or blank	7	Module 1: Pseudo Range based on the control sensor range
2	1	Module 2: control sensor
2	2	Module 2: source pressure +ve
2	3	Module 2: source pressure -ve
2	4	Module 2: barometric range (optional)
2	5	Module 2: CM3 reference sensor (if fitted)
2	6	Module 2: external IDOS sensor
2	7	Module 2: Pseudo Range based on the control sensor range

# :INST:CONT:SENS:NEGC

Applicability PACE6000

### Command Syntax

n/a

Parameter:

Short form:

Function:

### Query Syntax

#### :INSTrument:CONTroller[x]:SENSor[y]:NEGCa?

Use the CONT index(x) to determine which control module 1 (or blank) or 2. Both :INST:CONT and :INST:CONT1 will address control module 1, whilst :INST:CONT2 addresses only control module 2.

where y (sensor number) = 1, 2...5 (default -1)

Short form: :INST:CONT:SENS:NEGC?

Function: Queries sensor negative calibration.

Response: <boolean>

0 - negative calibration not supported

1 - negative calibration supported.

### Description

This command query returns sensor negative calibration supported or not supported. Used in DPI515 emulation; for PACE6000 this query always returns '1'.

x	y	PACE6000 Sensor
1 or blank	1	Module 1: control sensor
1 or blank	2	Module 1: source pressure +ve
1 or blank	3	Module 1: source pressure -ve
1 or blank	4	Module 1: barometric range (optional)
1 or blank	5	Module 1: CM3 reference sensor (if fitted)
2	1	Module 2: control sensor
2	2	Module 2: source pressure +ve
2	3	Module 2: source pressure -ve
2	4	Module 2: barometric range (optional)
2	5	Module 2: CM3 reference sensor (if fitted)

### Examples:

TX> :INST:CONT1:SENS:NEGC?

RX> :INST:CONT1:SENS:NEGC 1

Default - module 1 control sensor NEGcal.

TX> :INST:CONT1:SENS1:NEGC?

RX> :INST:CONT1:SENS:NEGC 1

Returns module 1 control sensor NEGcal.

TX> :INST:CONT1:SENS2:NEGC?

RX> :INST:CONT1:SENS2:NEGC 1

Returns module 1 +ve source sensor NEGcal.

TX> :INST:CONT1:SENS3:NEGC?

RX> :INST:CONT1:SENS3:NEGC 1

Returns module 1 –ve source sensor NEGcal.

TX> :INST:CONT1:SENS4:NEGC?

RX> :INST:CONT1:SENS4:NEGC 1

Returns module 1 barometric sensor NEGcal.

TX> :INST:CONT2:SENS1:NEGC?

RX> :INST:CONT2:SENS1:NEGC 1

Returns module 2 control sensor NEGcal.

TX> :INST:CONT2:SENS2:NEGC?

RX> :INST:CONT2:SENS2:NEGC 1

Returns module 2 +ve source sensor NEGcal.

TX> :INST:CONT2:SENS3:NEGC?

RX> :INST:CONT2:SENS3:NEGC 1

Returns module 2 –ve source sensor NEGcal.

TX> :INST:CONT2:SENS4:NEGC?

RX> :INST:CONT2:SENS4:NEGC 1

Returns module 2 barometric sensor NEGcal.

# :INST:CONT:SENS:SN

Applicability PACE6000

### Command Syntax

n/a

Parameter:

Short form:

Function:

### Query Syntax

#### :INSTrument:CONTroller[x]:SENSor[y]:Serial Number?

Use the CONT index(x) to determine which control module 1 (or blank) or 2. Both :INST:CONT and :INST:CONT1 will address control module 1, whilst :INST:CONT2 addresses only control module 2.

where y (sensor number) = 1, 2...6 (default -1)

Short form: :INST:CONT:SENS:SN?

Function: Queries the sensor serial number.

Response: Gets the serial number of selected sensor [y].

where y is the sensor number designated in the table below.

### Description

This query gets the serial number of selected sensor.

x	y	PACE6000 Sensor
1 or blank	1	Module 1: control sensor
1 or blank	2	Module 1: source pressure +ve
1 or blank	3	Module 1: source pressure -ve
1 or blank	4	Module 1: barometric range (optional)
1 or blank	5	Module 1: CM3 reference sensor (if fitted)
1 or blank	6	Module 1: external IDOS sensor
2	1	Module 2: control sensor
2	2	Module 2: source pressure +ve
2	3	Module 2: source pressure -ve
2	4	Module 2: barometric range (optional)
2	5	Module 2: CM3 reference sensor (if fitted)
2	6	Module 2: external IDOS sensor

## :INST:DISP

Applicability PACE6000

### Command Syntax

#### :INSTrument:DISPlay

Parameter: Enumerated character single or dual

Short form: :INST:DISP

Function: Sets the single or dual display mode.

### Query Syntax

#### :INSTrument:DISPlay?

Short form: :INST:DISP?

Function: Queries the display setting - single or dual.

Response: Enumerated character single or dual

### Description

This command sets the single or dual display mode. The query returns display setting single or dual display mode.

### Example:

```
TX> :INST:DISP?           ask display mode
RX> :INST:DISP SING       in single mode
TX> :INST:DISP DUAL       change to dual display mode
TX> :INST:DISP?           ask display mode
RX> :INST:DISP DUAL       in dual display mode
TX> :INST:DISP SINGLE     change to single display mode
TX> :INST:DISP?           ask display mode
RX> :INST:DISP SING       change to single display mode
```

In the single display mode:

```
TX> :INST:CAT?
RX> :INST:CAT "7.00barg","BAROMETER","8.00bara","3.50barg","4.50bara"
TX> :INST:CAT2?
RX> :INST:CAT2 "7.00barg","BAROMETER","8.00bara","3.50barg","4.50bara"
```

# :INST:LIM

Applicability PACE1000, PACE5000

### Command Syntax

n/a

Parameter:

Short form:

Function:

### Query Syntax

**:INSTrument:[LIMits][x]?**

where: x (sensor number) = 1, 2...10 (default - 1).

Short form: :INST?

Function: Queries the upper and lower full-scale limits of the fitted sensor ranges.  
The index number x is used to index into the list of available ranges.

Response: A string representing the range, a number representing the upper full-scale and a number representing the lower full-scale.

### Description

This query returns a string representing the range, a number representing the upper full-scale and lower full-scale.

x	PACE1000 Sensor	PACE5000 Sensor
1	Internal sensor number 1	Module 1: control sensor
2	Internal sensor number 2	Module 1: source pressure +ve
3	Internal sensor number 3	Module 1: source pressure -ve
4	External IDOS sensor number 1	Module 1: barometric sensor (optional)
5	External IDOS sensor number 2	Module 1: reference sensor (if fitted)
6	External IDOS sensor number 3	
7	Pseudo absolute sensor 1	
8	Pseudo absolute sensor 2	
9	Pseudo gauge sensor 1	
10	Pseudo gauge sensor 2	

### Example:

```
TX> :INST:LIM?
```

```
RX> :INST:LIM "7.00barg", 7350.0000000, -1100.0000000
```

```
TX> :INST:LIM1?
```

```
RX> :INST:LIM "7.00barg", 7350.0000000, -1100.0000000
```

```
TX> :INST:LIM2?
```



RX> :INST:LIM2 "20.00barg", 21000.0000000, -1100.0000000

TX> :INST:LIM3?

RX> :INST:LIM3 "2.00barg", 2100.0000000, -1100.0000000

**Note:** For PACE1000, the parameters in the above table are valid if the user has not modified the default COMMS RANGE table.

If there is no sensor stored in the COMMS RANGE table slot, “:INST:LIM "0.00bar", 0.0, 0.0” may be returned.

### **:INST:MAC**

Applicability PACE1000, PACE5000, PACE6000

#### **Command Syntax**

**n/a**

Parameter:

Short form:

Function:

#### **Query Syntax**

**:INSTrument:MACaddress?**

Short form: :INST:MAC?

Function: Queries the MAC internet address.

Response: Address string

#### **Description**

This command returns the Media Access Control (MAC) address string.

#### **Example:**

TX> :INST:MAC?

RX> :INST:MAC "00-D0-1C-0B-1B-1A"

## :INST:SENS

Applicability      PACE1000, PACE5000

### Command Syntax

n/a

Parameter:

Short form:

Function:

### Query Syntax

#### :INST:SENSor?

Short form:            :INST:SENS?

Function:              Queries the transducer range (sensor).

Response:              Returns sensor range.

### Description

This command returns the transducer range. Only module 1 on a PACE6000 can be addressed when using this command, for PACE6000 module 1 and module 2 addressing refer to the command. :INST:CONT:SENS

### Example:

```
TX> :INST:SENS?
```

```
RX> :INST:SENS "7.00barg"
```

```
TX> :INST:SENS1?
```

```
RX> :INST:SENS "7.00barg"
```

```
TX> :INST:SENS2?
```

```
RX> :INST:SENS2 "20.00barg"
```

```
TX> :INST:SENS3?
```

```
RX> :INST:SENS3 "2.00barg"
```

```
TX> :INST:SENS4?
```

```
RX> :INST:SENS4 "BAROMETER"
```

```
TX> :INST:SENS5?
```

```
RX> :INST:SENS5 "3.50barg"
```

```
TX> :INST:SENS6?
```

```
RX> :INST:SENS6 "20.00barg"
```

```
TX> :INST:SENS7?
```

```
RX> :INST:SENS7 "10.00barg"
```

```
TX> :INST:SENS8?
```

```
RX> :INST:SENS8 "BAROMETER"
```

# :INST:SENS:CALD

Applicability PACE1000, PACE5000

### Command Syntax

n/a

Parameter:

Short form:

Function:

### Query Syntax

#### :INSTrument:SENSor[x]:CALD[y]?

where x (sensor number) = 1, 2...10 (default -1) y = 1, 2, 3...10 (y times last calibration date)

Short form: :INST:SENS:CALD?

Function: Queries sensor calibration dates in the form yyyy, mm, dd.

Response: Returns sensor [x] with [y] calibration date:

where:

x is the sensor number, x = 1, 2...8

y is the y<sup>th</sup> calibration date for sensor x.

y = 1, 2, 3...10 calibration dates stored for each sensor.

### Description

This query returns the following:

x	PACE1000 Sensor	PACE5000 Sensor
1 or blank	Internal sensor number 1	Module 1: control sensor
2	Internal sensor number 2	Module 1: source pressure +ve
3	Internal sensor number 3	Module 1: source pressure -ve
4	External IDOS sensor number 1	Module 1: barometric sensor (optional)
5	External IDOS sensor number 2	Module 1: reference sensor (if fitted)
6	External IDOS sensor number 3	
7	Pseudo absolute sensor 1	
8	Pseudo absolute sensor 2	
9	Pseudo gauge sensor 1	
10	Pseudo gauge sensor 2	

### Example

```
TX> :INST:SENS5:CALD1?
```

```
RX> :INST:SENS5:CALD 2019, 11, 21
```

```
TX> :INST:SENS5:CALD2?
```

```
RX> :INST:SENS5:CALD2 2019, 11, 17
```

This shows that the external IDOS sensor number 2 was last calibrated on 21<sup>st</sup> November 2019 and the previous calibration was on 17<sup>th</sup> November 2019.

**Note:** For PACE1000, the default date is 01/01/2000 which means no previous calibration date is available. However, the response may be displayed as -1,-1,-1 if the user has modified the default COMMS RANGE table.

If there is no sensor stored in the COMMS RANGE table slot, an error of -1, -1, -1 is returned.

A pseudo-range does not return a calibration date.

# :INST:SENS:FULL

Applicability PACE1000 and PACE5000

### Command Syntax

n/a

Parameter:

Short form:

Function:

### Query Syntax

#### :INSTrument:SENSor[x]:FULLscale?

where: x = 1, 2...10 is the sensor number. It defaults to 1.

Short form: :INST:SENS[x]:FULL?

Function: Queries sensor full-scale value.

Response: Returns the full-scale value of the selected sensor.

### Description

This query returns the following:

x	PACE1000 Sensor	PACE5000 Sensor
1	Internal sensor number 1	Module 1: control sensor
2	Internal sensor number 2	Module 1: source pressure +ve
3	Internal sensor number 3	Module 1: source pressure -ve
4	External IDOS sensor number 1	Module 1: barometric sensor (optional)
5	External IDOS sensor number 2	Module 1: reference sensor (if fitted)
6	External IDOS sensor number 3	
7	Pseudo absolute sensor 1	
8	Pseudo absolute sensor 2	
9	Pseudo gauge sensor 1	
10	Pseudo gauge sensor 2	

### Example:

```
TX> :INST:SENS:FULL?
```

```
RX> :INST:SENS:FULL 7.0000000
```

Default - module 1 control sensor full-scale.

```
TX> :INST:SENS1:FULL?
```

```
RX> :INST:SENS:FULL 7.0000000
```

Returns module 1 control sensor full-scale.

```
TX> :INST:SENS2:FULL?
```

```
RX> :INST:SENS2:FULL 20.0000000
```

Returns module 1 +ve source sensor full-scale.

TX> :INST:SENS3:FULL?

RX> :INST:SENS3:FULL 2.0000000

Returns module 1 –ve source sensor full-scale.

TX> :INST:SENS4:FULL?

RX> :INST:SENS4:FULL 1.1500000

Returns module 1 barometric sensor full-scale.

# :INST:SENS:NEGC

Applicability PACE1000, PACE5000

### Command Syntax

n/a

Parameter:

Short form:

Function:

### Query Syntax

**:INSTrument:SENSor[x]:NEGCa?**

where: x = 1, 2...8 is the sensor number. It defaults to 1.

Short form: :INST:SENS:NEGC?

Function: Queries sensor negative calibration.

Response: <boolean>

0 - negative calibration not supported

1 - negative calibration supported.

### Description

This command query returns sensor negative calibration supported or not supported. Used in DPI515 emulation; for PACE5000 this query always returns '1'.

x	PACE5000 Sensor	PACE1000 Sensor
1	Module 1: control sensor	Internal sensor 1
2	Module 1: source pressure +ve	Internal sensor 2
3	Module 1: source pressure -ve	Internal sensor 3
4	Module 1: barometric range (optional)	External IDOS-1
5	Module 1: reference sensor (if fitted)	External IDOS-2
6		External IDOS-3

### Examples:

TX> :INST:SENS:NEGC?

RX> :INST:SENS:NEGC 1

Default - module 1 control sensor NEGcal.

TX> :INST:SENS1:NEGC?

RX> :INST:SENS:NEGC 1

Returns module 1 control sensor NEGcal.

TX> :INST:SENS2:NEGC?

RX> :INST:SENS2:NEGC 1

Returns module 1 +ve source sensor NEGcal.

TX> :INST:SENS3:NEGC?



RX> :INST:SENS3:NEGC 1

Returns module 1 –ve source sensor NEGcal.

TX> :INST:SENS4:NEGC?

RX> :INST:SENS4:NEGC 1

Returns module 1 barometric sensor NEGcal.

# :INST:SENS:READ

Applicability PACE1000

### Command Syntax

n/a

Parameter:

Short form:

Function:

### Query Syntax

**:INSTrument:SENSor[x]:READing?**

Short form: :INST:SENS:READ?

Function: Queries sensor reading.

Response: Gets reading of selected sensor [x].  
where x is the sensor number.  
x = 1, 2...8

### Description

This query gets the filtered reading followed by the instantaneous reading from the selected sensor.

**Note:** INST:SENS:READ command will always return the sensor reading in mbar regardless of the units set via SCPI or locally.

## :INST:SENS:SN

Applicability PACE1000, PACE5000

### Command Syntax

n/a

Parameter:

Short form:

Function:

### Query Syntax

#### :INSTrument:SENSor[x]:Serial Number?

Short form: :INST:SENS:SN?

Function: Queries the sensor serial number.

Response: Gets the serial number of selected sensor [x].

where x is the sensor number designated in the table below.

### Description

This query gets the serial number of selected sensor.

To query the serial number of the PACE1000, PACE1000 internal analogue option or VFC option refer to the command INST:SN

For PACE6000 module 2, refer to query :INST:CONT:SENS:SN

x	PACE1000 Sensor	PACE5000 Sensor
1	Internal sensor number 1	Module 1: control sensor
2	Internal sensor number 2	Module 1: source pressure +ve
3	Internal sensor number 3	Module 1: source pressure -ve
4	External IDOS sensor number 1	Module 1: barometric sensor (optional)
5	External IDOS sensor number 2	Module 1: reference sensor (if fitted)
6	External IDOS sensor number 3	Module 1: external IDOS sensor
7	Pseudo absolute sensor 1 <sup>a</sup>	
8	Pseudo absolute sensor 2 <sup>a</sup>	
9	Pseudo gauge sensor 1 <sup>a</sup>	
10	Pseudo gauge sensor 2 <sup>a</sup>	

- a. Returns the serial number of the main sensor allocated to create a pseudo range (not the barometric sensor).

# :INST:SENS:ZERO

Applicability: PACE1000

### Command Syntax

#### INSTrument:SENSor[x]:ZERO

where: x = 1, 2...8 is the sensor number. It defaults to 1.

Parameter: <integer> 1, 2...8

Short form: :INST:SENS[x]:ZERO

Function: Performs a zero on the selected sensor specified in the sensor index.

### Query Syntax

#### :INSTrument:SENSor[x]:ZERO?

where: x = 1, 2...8 is the sensor number. It defaults to 1.

Short form: :INST:SENS[x]:ZERO?

Function: Queries sensor zero condition.

Response: Gets zero condition [y] of selected sensor [x].  
where x is the sensor number.  
x = 1, 2...8

### Description

The command selects a sensor and performs a zero. The query gets the zero condition after a zero has been performed on the selected sensor.

y	Zero Condition
0	Zero ok
1	Zero in progress
2	Zero timed out
3	Zero outside limits
4	Zero aborted

### Example:

```
TX> :INST:SENS2:ZERO           Zeros sensor 2
TX> :INST:SENS2:ZERO?         Queries sensor 2 status
RX> :INST:SENS2:ZERO 1       Sensor 2 zero in progress
```

## :INST:SN

Applicability: PACE1000, PACE5000, PACE6000

### Command Syntax

n/a

Parameter:

Short form:

Function:

### Query Syntax

#### :INSTrument:SN[x]?

where: x = 1, 2...7 is the hardware serial number. If x is blank, then x defaults to 1.

Short form: :INST:SN[x]?

Function: Used to query the serial numbers of the instrument hardware and options.

Response: Integers representing serial numbers.

### Description

This query returns the serial numbers of the hardware installed.

x	Description
1 or blank	PACE1000, PACE5000 or PACE6000
2	Control module 1 <sup>a</sup>
3	Control module 2 <sup>a</sup>
4	Analogue Output 1 <sup>b</sup>
5	Analogue Output 2 <sup>b</sup>
6	VFC 1 <sup>b</sup>
7	VFC 2 <sup>b</sup>

a. Not applicable to PACE indicators.

b. Option must be fitted.

**Note:** Depending on future instrument development, additional numbers may be included.

### Example:

TX> :INST:SN?

RX> :INST:SN 68795

TX> :INST:SN1?

RX> :INST:SN 68795

TX> :INST:SN2?

RX> :INST:SN2 2803347

TX> :INST:SN3?

RX> :INST:SN3 65795

## Chapter 4. Command and Query Summary

---

TX> :INST:SN4?

RX> :INST:SN4 68884

TX> :INST:SN5?

RX> :INST:SN5 0

TX> :INST:SN6?

RX> :INST:SN6 88704

TX> :INST:SN7?

RX> :INST:SN7 0

In this example, 'RX> :INST:SN5 0' and 'RX> :INST:SN7 0' mean the 2<sup>nd</sup> Analogue Output and 2<sup>nd</sup> VFC board are not installed. To query the serial number of PACE1000 sensors refer to the command INST:SENS:SN.

## :INST:TASK

Applicability: PACE1000, PACE5000, PACE6000

### Command Syntax

#### :INSTrument:TASK

Parameter: Enumerated

Short form: :INST:TASK

Function: Sets the task

### Query Syntax

#### :INSTrument:TASK?

Short form: :INST:TASK?

Function: Used to query the task set.

Response: Enumerated character representing task.

### Description

This command sets the task and the query returns the task setting.

Task	PACE1000	PACE5000	PACE6000
AERONAUTICAL	✓		
AIRFIELD	✓		
AIRSPEEDLEAK	✓		
ALTLEAK	✓		
BAROGRAPH	✓		
BASIC	✓	✓	✓
BURSTTEST		✓	✓
DIVIDER		✓	✓
LEAKTEST	✓	✓	✓
PRESET		✓	✓
SWITCHTEST		✓	✓
TESTPROGRAM		✓	✓

# **:INST:TASK:AERO**

Applicability: PACE1000, PACE6000

### **Command Syntax**

**:INSTrument:TASK:AERO:[RANGe]**

Parameter:

Short form: :INST:TASK:AERO

Function: Sets the aeronautical ranges: pressure, altitude, speed and MACH.

### **Query Syntax**

**:INSTrument:TASK:AERO:[RANGe]?**

Short form: :INST:TASK:AERO?

Function: Used to query the task set.

Response: Integers representing task numbers.

### **Description**

The command sets the aeronautical ranges: pressure, altitude, speed and MACH. This query returns the aeronautical range setting.



## :INST:TASK:LKT

Applicability: PACE5000, PACE6000

### Command Syntax

#### :INSTrument:TASK[x]:LeaKT

where x = 1 = module 1 or x = 2 = module 2 (if x is blank the default is module 1).

Parameter: See table below

Short form: :INST:TASK:LKT

Function: Sets the task

### Query Syntax

#### :INSTrument:TASK[x]:LeaKT

where x = 1 = module 1 or x = 2 = module 2 (if x is blank the default is module 1).

Short form: :INST:TASK:LKT

Queries: See table below

Function: Used to query the task set.

Response: Enumerated character representing task.

### Description

This command configures the task and the query returns the task setting.

**Note:** Thermal stabilization time is not available on PACE6000 prior to DK0388 V02.01.18 and PACE5000 prior to DK0367 V03.02.09.

### Example:

Tx	Rx	Description
:INST:TASK1:LKT:TPR1?	:INST:TASK:LKT:TPR 0.0	Queries Module 1 Test Pressure 1
:INST:TASK1:LKT:TPR1 -50		Sets Module 1 Test Pressure 1 value = -50
:INST:TASK1:LKT:TPR2?	:INST:TASK1:LKT:TPR2 4.0000000	Queries Module 1 Test Pressure 2
:INST:TASK1:LKT:TPR2 70		Sets Module 1 Test Pressure 2 value = 70
:INST:TASK1:LKT:TPEN?	:INST:TASK:LKT:TPEN 0.0	Queries Module 1 End Pressure
:INST:TASK1:LKT:TPEN 1.0		Sets End Pressure value = 1.0
:INST:TASK1:LKT:CONT?	:INST:TASK:LKT:CONT 0, 5, 0	Queries Control dwell time (hh,mm,ss)
:INST:TASK1:LKT:CONT 0,4,0		Sets module 1 Control dwell time
:INST:TASK1:LKT:THER?	:INST:TASK:LKT:THER 0, 2, 0	Queries module 1 the thermal stabilization time
:INST:TASK1:LKT:THER 0,1,0		Sets module 1 thermal stabilization time
:INST:TASK1:LKT:MEAS?	:INST:TASK:LKT:MEAS 0, 5, 0	Queries module 1 Measure dwell time
:INST:TASK1:LKT:MEAS 0,2,0		Sets module Measure dwell time
:INST:TASK1:LKT:UNIT?	:INST:TASK:LKT:UNIT 0	Queries module 1 Leak rate = per second

## Chapter 4. Command and Query Summary

<b>Tx</b>	<b>Rx</b>	<b>Description</b>
:INST:TASK1:LKT:UNIT 1		Sets leak rate = per minute
:INST:TASK1:LKT:STAR?	:INST:TASK:LKT:STAR 0	Queries module 1 leak task status, not in progress
:INST:TASK1:LKT:STAR 1		Starts module 1 leak task
:INST:TASK1:LKT:STAR?	:INST:TASK:LKT:STAR 1	Query leak test task status, in progress
:INST:TASK1:LKT:RES1?	:INST:TASK:LKT:RES - 0.0015256	Queries module 1 Test Pressure 1 result
:INST:TASK1:LKT:RES2?	:INST:TASK:LKT:RES2 0.0025400	Queries module 1 Test Pressure 2 result
:INST:TASK:LKT:TIME?	:INST:TASK:LKT:TIME 1, 0, 0, 0, 0	Queries the leak test active timings :INST:TASK:LKT:TIME x, i, hh, mm, ss Where: x=0(stopped), 1=(running) i=0, no timer running i=1, control dwell active time (TP1) i=2, thermal stability active time (TP1) i=3, measure dwell active time (TP1) i=4, control dwell active time(TP2) i=5, thermal stability active time (TP2) i=6, measure dwell active time (TP2)

## :INST:TASK:SWT

Applicability: PACE5000, PACE6000

### Command Syntax

#### :INSTrument:TASK[x]:SWT

where x = 1 = module 1 or x = 2 = module 2 (if x is blank the default is module 1).

Parameter: See table below.  
 Short form: See table below.  
 Function: Sets the task settings.  
 Default: -

### Query Syntax

#### :INSTrument:TASK[x]:SWT

where x = 1 = module 1 or x = 2 = module 2 (if x is blank the default is module 1).

Short form: See table below.  
 Queries: See table below.  
 Function: Used to query the task settings.  
 Response: Enumerated character representing task.

### Description

This command sets the task and the query returns the task setting.

### Example:

Tx	Rx	Description
:INST:TASK:SWT:STAR?	:INST:TASK:SWT:STAR 0	Queries the Start/Stop status of the test
:INST:TASK:SWT:STAR 1		Starts the switch test
:INST:TASK1:SWT:STRT:SETP?	:INST:TASK:SWT:STRT:SETP 0.0	Queries Module 1 Start Set-point
:INST:TASK1:SWT:STRT:SETP 0.0		Sets Module 1 Start Set-point 1 value = 0.0
:INST:TASK1:SWT:STRT:SLEW?	:INST:TASK:SWT:TEST:SLEW 120	Queries Module 1 Start Slew rate in Punits/(s or m)
:INST:TASK1:SWT:STRT:SLEW 12		Sets Module 1 Start Slew rate in Punits/(s or m)
:INST:TASK1:SWT:STRT:DWEL?	:INST:TASK:SWT:STRT:DWEL 0.0.5	Queries Module 1 Start Dwell rate (hh.mm.ss) 5s
:INST:TASK1:SWT:STRT:DWEL 0.1.0		Sets Module 1 Dwell time (hh,mm,ss)
:INST:TASK1:SWT:STRT:DEB?	:INST:TASK:SWT:STRT:DEB 50	Queries Module 1 Start Debounce time (xx ms)
:INST:TASK1:SWT:STRT:DEB 60		Sets Module 1 Start Debounce time (60 ms)

## Chapter 4. Command and Query Summary

<b>Tx</b>	<b>Rx</b>	<b>Description</b>
:INST:TASK1:SWT:TEST:SETP1?	:INST:TASK:SWT:TEST:SETP 0.00	Queries Module 1 Test Set-point 1
:INST:TASK1:SWT:TEST:SETP1 10.1		Sets Module 1 Test Set-point 1
:INST:TASK1:SWT:TEST:SETP2?	:INST:TASK:SWT:TEST:SETP2 0.0	Queries Module 1 Test Set-point 2
:INST:TASK1:SWT:TEST:SETP2 20.5		Sets Module 1 Test Set-point 2
:INST:TASK1:SWT:TEST:SLEW?	:INST:TASK:SWT:TEST:SLEW 100.0	Queries Module 1 Test Slew rate in Punits/(s or m)
:INST:TASK1:SWT:TEST:SLEW 200.0		Sets Module 1 Test Slew rate in Punits/(s or m)
:INST:TASK1:SWT:TEST:DWEL?	:INST:TASK:SWT:TEST:DWEL 0.0.0	Queries Module 1 Test Dwell time (hh.mm.ss)
:INST:TASK1:SWT:TEST:DWEL 0.0.6		Sets Module 1 Test Dwell time (hh.mm.ss) 6s
:INST:TASK1:SWT:TEST:REP?	:INST:TASK:SWT:TEST:REP 1	Queries Module 1 Test Repeat cycles (Integer)
:INST:TASK1:SWT:TEST:REP 2		Sets Module 1 Test Repeat cycles = 2 (Integer)
:INST:TASK1:SWT:TEST:REV?	:INST:TASK:SWT:TEST:REV 0	Queries Module 1 Test Auto Reverse (boolean) = off
:INST:TASK1:SWT:TEST:REV 1		Sets Module 1 Test Auto Reverse (boolean) = on
:INST:TASK1:SWT:END:SETP?	:INST:TASK:SWT:END:SETP 0.0	Queries Module 1 End Set-point in Punits
:INST:TASK1:SWT:END:SETP 5		Sets Module 1 End Set-point in Punits
:INST:TASK1:SWT:END:CONT?	:INST:TASK:SWT:END:CONT 0	Queries Module 1 End Controller state = Measure mode
:INST:TASK1:SWT:END:CONT 1		Sets Module 1 End Controller state = Control mode
:INST:TASK1:SWT:END:COND?	:INST:TASK:SWT:END:COND 0	Queries Module 1 End Condition = Normal
:INST:TASK1:SWT:END:COND 1		Sets Module 1 End Condition = Alarm
:INST:TASK:SWT:RES:OPEN:AVG?	INST:TASK:SWT:RES:OPEN:AVG 814.0	Queries the average Open Pressure from the results of the Switch Test
:INST:TASK:SWT:RES:OPEN:MIN?	INST:TASK:SWT:RES:OPEN:MIN 842.0	Queries the minimum Open Pressure from the results of the Switch Test
:INST:TASK:SWT:RES:OPEN:MAX?	INST:TASK:SWT:RES:OPEN:MAX 938.0	Queries the maximum Open Pressure from the results of the Switch Test

Tx	Rx	Description
:INST:TASK:SWT:RES:CLOS:AVG?	INST:TASK:SWT:RES:CLOS:AVG 1545.0	Queries the average Close Pressure from the results of the Switch Test
:INST:TASK:SWT:RES:CLOS:MIN?	INST:TASK:SWT:RES:CLOS:MIN 1447.0	Queries the minimum Close Pressure from the results of the Switch Test
:INST:TASK:SWT:RES:CLOS:MAX?	INST:TASK:SWT:RES:CLOS:MAX 1643.0	Queries the maximum Close Pressure from the results of the Switch Test

# :INST:UNIT

Applicability: PACE1000, PACE5000, PACE6000

### Command Syntax

n/a

Parameter:

Short form:

### Query Syntax

#### :INST:UNIT?

where: x = 1, 2...32 is the unit number. It defaults to 1.

Short form: :INST:UNIT?

Function: Used to query the units of measurement available. This does not query the current unit in use (refer to the 'UNIT' family of commands/queries).

Response: Enumerated character string.

### Description

This command sets the units of measurement available to the instrument.

### Examples:

TX> :INST:UNIT1?

RX> :INST:UNIT MBAR

TX> :INST:UNIT2?

RX> :INST:UNIT2 BAR

TX> :INST:UNIT3?

RX> :INST:UNIT3 PA

TX> :INST:UNIT4?

RX> :INST:UNIT4 HPA

TX> :INST:UNIT5?

RX> :INST:UNIT5 KPA

TX> :INST:UNIT6?

RX> :INST:UNIT6 MPA

TX> :INST:UNIT7?

RX> :INST:UNIT7 MMHG

TX> :INST:UNIT8?

RX> :INST:UNIT8 CMHG

TX> :INST:UNIT9?

RX> :INST:UNIT9 MHG

TX> :INST:UNIT10?

RX> :INST:UNIT10 INHG

TX> :INST:UNIT11?

---

```
RX> :INST:UNIT11 KG/CM2
TX> :INST:UNIT12?
RX> :INST:UNIT12 KG/M2
TX> :INST:UNIT13?
RX> :INST:UNIT13 MMH2O_4
TX> :INST:UNIT14?
RX> :INST:UNIT14 CMH2O_4
TX> :INST:UNIT15?
RX> :INST:UNIT15 MH2O_4
TX> :INST:UNIT16?
RX> :INST:UNIT16 MMH2O_20
TX> :INST:UNIT17?
RX> :INST:UNIT17 CMH2O_20
TX> :INST:UNIT18?
RX> :INST:UNIT18 MH2O_20
TX> :INST:UNIT19?
RX> :INST:UNIT19 TORR
TX> :INST:UNIT20?
RX> :INST:UNIT20 ATM
TX> :INST:UNIT21?
RX> :INST:UNIT21 PSI
TX> :INST:UNIT22?
RX> :INST:UNIT22 LB/FT2
TX> :INST:UNIT23?
RX> :INST:UNIT23 INH2O_4
TX> :INST:UNIT24?
RX> :INST:UNIT24 INH2O_20
TX> :INST:UNIT25?
RX> :INST:UNIT25 INH2O_60
TX> :INST:UNIT26?
RX> :INST:UNIT26 FTH2O_4
TX> :INST:UNIT27?
RX> :INST:UNIT27 FTH2O_20
TX> :INST:UNIT28?
RX> :INST:UNIT28 FTH2O_60
TX> :INST:UNIT29?
RX> :INST:UNIT29 USER1
TX> :INST:UNIT30?
RX> :INST:UNIT30 USER2
TX> :INST:UNIT31?
RX> :INST:UNIT31 USER3
```

## Chapter 4. Command and Query Summary

---

TX> :INST:UNIT32?

RX> :INST:UNIT32 USER4



# :INST:VERS

Applicability: PACE1000, PACE5000, PACE6000

## Command Syntax

n/a

Parameter:

Short form:

Function:

## Query Syntax

### :INSTrument:VERSion[x]?

where: x = 1, 2...15 is the software version. It defaults to 1.

Short form: :INST:VERS[x]?

Function: Queries the software versions of the instrument and options.

Response: Returns strings representing the software version:

## Description

x	Software Item
1	Instrument main code
2	Instrument OS build
3	Instrument boot ROM
4	Controller 1 main code
5	Controller 1 Boot code
6	Controller 2 main code
7	Controller 2 Boot code
8	Analogue output board 1 main code
9	Analogue output board 1 boot code
10	Analogue output board 2 main code
11	Analogue output board 2 boot code
12	VFC board 1 main code
13	VFC board 1 boot code
14	VFC board 2 main code
15	VFC board 2 boot code

## Examples:

TX> :Inst:Vers?

RX> :INST:VERS "00.01.09"

TX> :Inst:Vers1?

## Chapter 4. Command and Query Summary

---

RX> :INST:VERS "00.01.09"

TX> :Inst:Vers2?

RX> :INST:VERS2 "01.06.16"

TX> :Inst:Vers3?

RX> :INST:VERS3 "01.01.04"

TX> :Inst:Vers4?

RX> :INST:VERS4 "02.00.29"

TX> :Inst:Vers5?

RX> :INST:VERS5 "01.00.00"

TX> :Inst:Vers6?

RX> :INST:VERS6 "02.00.29"

TX> :Inst:Vers7?

RX> :INST:VERS7 "01.00.00"

TX> :Inst:Vers8?

RX> :INST:VERS8 "00.01.53"

TX> :Inst:Vers9?

RX> :INST:VERS9 "00.00.40"

TX> :Inst:Vers10?

RX> :INST:VERS10 ""

TX> :Inst:Vers11?

RX> :INST:VERS11 ""

TX> :Inst:Vers12?

RX> :INST:VERS12 "00.01.53"

TX> :Inst:Vers13?

RX> :INST:VERS13 "00.00.40"

TX> :Inst:Vers14?

RX> :INST:VERS14 ""

TX> :Inst:Vers15?

RX> :INST:VERS15 ""

**Note:** An empty return string means that the option is not installed.

# OUTPut

The OUTPut subsystem turns the pressure controller on/off and controls the state of the logical outputs.

## :OUTP:ISOL:STAT



**CAUTION** Opening a module output isolation valve with high pressure in the external system can cause PACE to malfunction. Equalize the external system pressure to zero gauge, or use other means to identify the external system pressure, before opening the isolation valve.

Applicability: PACE5000, PACE6000

### Command Syntax

#### :OUTPut[x]:ISOLation:STATe

where x = 1 = module 1 or x = 2 = module 2 (if x is blank the default is module 1)

Parameter: <boolean>  
 0 OFF - turn isolation valve of the module [x] OFF  
 1 ON - turn isolation valve of the module [x] ON

Short form: :OUTP:ISOL

Function: Turns isolation valve ON and OFF

### Query Syntax

#### :OUTPut[x]:ISOLation:STATe?

where x = 1 = module 1 or x = 2 = module 2 (if x is blank the default is module 1)

Short form: :OUTP:ISOL?

Function: Asks for isolation valve ON/OFF status.

Response: 0 - isolation valve OFF (Closed/Isolated)  
 1 - isolation valve ON (Open/Non-isolated)

### Description

The output port isolation valve of module 1 or module 2 can be queried and switched on and off.

### Example:

Module 1	Module 2	Remarks
TX> :OUTP1:ISOL:STAT 1	:OUTP2:ISOL:STAT 1	Opens the output port isolation valve
TX> :OUTP1:ISOL:STAT?	:OUTP2:ISOL:STAT?	Queries the current state of the valve
RX> :OUTP:ISOL:STAT 1	:OUTP2:ISOL:STAT 1	Query reply = valve open
TX> :OUTP1:ISOL:STAT 0	:OUTP2:ISOL:STAT 0	Closes the output port isolation valve
TX> :OUTP1:ISOL:STAT?	:OUTP2:ISOL:STAT?	Queries the current state of the valve
RX> :OUTP:ISOL:STAT 0	:OUTP2:ISOL:STAT 0	Query reply = valve closed

# :OUTP:LOG

Applicability: PACE1000, PACE5000

### Command Syntax

**:OUTPut[x]:LOGic[y]<space><parameter>**

where: x = VFC 1 or VFC 2 (default = 1) and y = VFC relay 1, VFC relay 2 or VFC relay 3 represents the relay number (default = 1)

Parameter: <boolean>  
0 - turn relay [y] OFF  
1 - turn relay [y] ON

Form: :OUTP[x]:LOG[y]

Function: Turns relay ON and OFF

Default: VFC 1 of Relay 1

### Query Syntax

**:OUTPut[x]:LOGic[y]?**

where: x = VFC 1 or VFC 2 (default = 1) and y = VFC relay 1, VFC relay 2 or VFC relay 3 represents the relay number (default = 1).

Form: :OUTP[x]:LOG[y]?

Function: Asks for relay ON/OFF status.

Response: 0 - relay OFF  
1 - relay ON

### Description

The VFC option must be installed and each VFC relay must be set to 'communications' through the front panel measure setup, VFC setup display screen. Alternatively check under Instrument status, Volt-free contact status. If the volt-free contact option is installed but the relay not set to 'communications' a system error query will return ":SYST:ERR -240,"Hardware error;Incorrect VFC setup".

The three relays can be queried and switched on and off. Omitting [x] or [y], the default of 1 is used so this will address VFC 1 Relay 1.

### Example:

Tx	Rx	Remarks
:OUTP1:LOG1?	:OUTP:LOG 0	Query VFC1/R1 Contact NC = Closed, NO = Open
:OUTP1:LOG1 1	None	Set VFC1/R1 contact
:OUTP1:LOG1?	:OUTP:LOG 1	Query VFC1/R1 Contact NC = Open, NO = Closed
:OUTP1:LOG2?	:OUTP:LOG2 0	Query VFC1/R2 Contact NC = Closed, NO = Open
:OUTP1:LOG2 1	None	Set VFC1/R2 contact
:OUTP1:LOG2?	:OUTP:LOG2 1	Query VFC1/R2 Contact NC = Open, NO = Closed

Tx	Rx	Remarks
:OUTP1:LOG2 0	None	Set VFC1/R2 contact
:OUTP1:LOG2?	:OUTP:LOG2 0	Query VFC1/R2 Contact NC = Closed, NO = Open
:OUTP1:LOG3?	:OUTP:LOG3 0	Query VFC1/R3 Contact NC = Closed, NO = Open

# :OUTP:LOG:LEV

Applicability: PACE6000

### Command Syntax

**:OUTPut[x]:LOGic[y]:LEVel<space><parameter>**

where: x = VFC 1 or VFC 2 (default = 1) and y = VFC relay 1, VFC relay 2 or VFC relay 3  
represents the relay number (default = 1)

Parameter: <boolean>  
0 - turn relay [y] OFF  
1 - turn relay [y] ON

Form: :OUTP[x]:LOG[y]:LEV

Function: Turns relay ON and OFF

Default: VFC 1 of Relay 1

### Query Syntax

**:OUTPut[x]:LOGic[y]:LEVel?**

where: x = VFC 1 or VFC 2 (default = 1) and y = VFC relay 1, VFC relay 2 or VFC relay 3  
represents the relay number (default = 1).

Form: :OUTP[x]:LOG[y]:LEV?

Function: Asks for relay ON/OFF status.

Response: 0 - relay OFF  
1 - relay ON

### Description

The VFC option must be installed and each VFC relay must be set to 'communications' through the front panel measure setup, VFC setup display screen. Alternatively check under Instrument status, Volt-free contact status. If the volt-free contact option is installed but the relay not set to 'communications' a system error query will return ":SYST:ERR -240,"Hardware error;Incorrect VFC setup".

The three relays can be queried and switched on and off. Omitting [x] or [y], the default of 1 is used so this will address VFC 1 Relay 1.

### Example:

Tx	Rx	Remarks
:OUTP1:LOG1:LEV?	:OUTP:LOG:LEV 0	Query VFC1/R1 Contact NC = Closed, NO = Open
:OUTP1:LOG1:LEV 1	None	Set VFC1/R1 contact
:OUTP1:LOG1:LEV?	:OUTP:LOG:LEV 1	Query VFC1/R1 Contact NC = Open, NO = Closed
:OUTP1:LOG2:LEV?	:OUTP:LOG2:LEV 0	Query VFC1/R2 Contact NC = Closed, NO = Open
:OUTP1:LOG2:LEV 1	None	Set VFC1/R2 contact
:OUTP1:LOG2:LEV?	:OUTP:LOG2:LEV 1	Query VFC1/R2 Contact NC = Open, NO = Closed

Tx	Rx	Remarks
:OUTP1:LOG2 0	None	Set VFC1/R2 contact
:OUTP1:LOG2?	:OUTP:LOG2 0	Query VFC1/R2 Contact NC = Closed, NO = Open
:OUTP1:LOG3?	:OUTP:LOG3 0	Query VFC1/R3 Contact NC = Closed, NO = Open

# :OUTP:MODE

Applicability: PACE5000, PACE6000

### Command Syntax

**:OUTPut[x]:MODE <enumerated>**

where: x (module) = 1 or 2 (default - 1)

Parameter: <enumerated> ACTive or PASSive or GAUGe

Short form: :OUTP[x]:MODE

Function: Sets control mode

Default: ACTive

### Query Syntax

**:OUTPut[x]:MODE?**

where: x (module) = 1 or 2 (default - 1)

Short form: :OUTP[x]:MODE?

Function: Asks for state of the controller control mode setting.

Response: ACTive or PASSive or GAUGe

### Description

Queries or sets the pressure controller control mode: Active or Passive or Gauge.

### Examples:

Tx	Rx	Remark
:OUTP1:MODE?	:OUTP:MODE ACT	Module 1 = Active control mode
:OUTP1:MODE GAUG		
:OUTP1:MODE?	:OUTP:MODE GAUG	Module 1 = Gauge control mode
:OUTP1:MODE PASS		
:OUTP1:MODE?	:OUTP:MODE PASS	Module 1 = Passive control mode
:OUTP1:MODE ACT		
:OUTP1:MODE?	:OUTP:MODE ACT	Module 1 = Active control mode
:OUTP2:MODE?	:OUTP2:MODE ACT	Module 2 = Active control mode
:OUTP2:MODE GAUG		
:OUTP2:MODE?	:OUTP2:MODE GAUG	Module 2 = Gauge control mode
:OUTP2:MODE PASS		
:OUTP2:MODE?	:OUTP2:MODE PASS	Module 2 = Passive control mode
:OUTP2:MODE ACT		
:OUTP2:MODE?	:OUTP2:MODE ACT	Module 2 = Active control mode



## :OUTP:STAT

Applicability: PACE5000, PACE6000

### Command Syntax

#### :OUTPut[x]:STATe <Boolean>

where: x (module) = 1 or 2 (default - 1)

Parameter: <boolean>  
0 - turn controller off  
1 - turns controller on

Short form: :OUTP

Function: Turn the pressure controller on/off

Default: 0

### Query Syntax

#### :OUTPut:STATe?

where: x (module) = 1 or 2 (default - 1)

Short form: :OUTP?

Function: Asks for state of pressure controller

Response: 0 - controller off

### Description

Sets or queries the state of the pressure controller.

### Example:

```
TX> :OUTP:STAT?
```

```
RX> :OUTP:STAT 0
```

The module 1 controller currently turned off.

To turn the module 1 controller off:

```
TX> :OUTP:STAT OFF
```

To turn the module 1 controller on:

```
TX> :OUTP:STAT ON
```

```
TX> :OUTP:STAT?
```

```
RX> :OUTP:STAT 1
```

# SENSe

The SENSe subsystem selects, configures and queries the measurement functions of the instrument.

## :SENS:AER

Applicability: PACE1000

### Command Syntax

n/a

Parameter:

Short form:

Function:

Default:

### Query Syntax

**:SENSe:AERonautical?**

Short form: :SENS:AER?

Function: This query reads the aeronautical sensor.

Response: This returns the Static pressure (Ps), Impact or Differential pressure (Qc) and Total pressure (Pt) values.

### Description

Queries the Ps, Qc and Pt reading for the aeronautical sensor in the selected aeronautical units.

**Note:** If the instrument is not in aeronautical mode it returns an error: -221, "Settings conflict".

---

## :SENS:ALT

Applicability: PACE1000, PACE6000

### Command Syntax

n/a

Parameter:

Short form:

Function:

### Query Syntax

#### **SENSe:ALTitude?**

Short form: :SENS:ALT?

Function: This query reads the aeronautical sensor.

Response: A decimal, altitude reading in the current aeronautical units.

### Description

Queries the altitude reading for the aeronautical sensor in the selected aeronautical units.

**Note:** If the instrument is not in aeronautical mode it returns an error: -221, "Settings conflict".

### **:SENS:ALT:INL**

Applicability: PACE6000

#### **Command Syntax**

**:SENSe[x][:ALTitude]:INLimits <decimal>**

where x = 1 or 2 is the module number (default - 1)

Parameter: <decimal> in-limits value as % full-scale

Short form: :SENS:INL <decimal>

Function: The instrument has an in-limits indicator. This can generate a service request when the pressure is within limits for a set time period.

Default: 0.01% full-scale  
(Minimum: 0% full-scale)  
(Maximum: 100% full-scale)

#### **Query Syntax**

**:SENSe[x][:ALTitude]:INLimits?**

where x = 1 or 2 is the module number (default - 1)

Short form: :SENS:INL?

Function: Query in-limits value

Response: Decimal representing in-limits value as % full-scale.

#### **Description**

Sets the in-limits value.

**Note:** If the instrument is not in aeronautical mode it returns an error: -221. Settings conflict.

---

## :SENS:ALT:INL:TIME

Applicability: PACE6000

### Command Syntax

**:SENSe[x][:ALTitude]:INLimits:TIME <decimal>**

where x = 1 or 2 is the module number (default - 1)

Parameter: <integer> in-limits time in seconds

Short form: :SENS:INL:TIME <decimal>

Function: Sets the time that the pressure has to be within limits before generating a service request.

Default: 2 seconds  
(Minimum: 2 seconds)  
(Maximum: 999 seconds)

### Query Syntax

**:SENSe[x][:ALTitude]:INLimits:TIME?**

where x = 1 or 2 is the module number (default - 1)

Short form: :SENS:INL:TIME?

Function: Query in-limits timers.

Response: Number representing in-limits time in seconds.

### Description

Sets the in-limits timer value.

**Note:** If the instrument is not in aeronautical mode it returns an error: -221. Settings conflict.

### **:SENS:ALT:RANG**

Applicability: PACE1000, PACE6000

#### **Command Syntax**

**n/a**

Parameter:

Short form:

Function:

#### **Query Syntax**

#### **SENSe:ALTitude:RANGe?**

Short form: :SENS:ALT:RANG?

Function: This queries the range of the aeronautical sensor.

Response: A string (number), representing altitude range in pressure units.

Example: 1.30 bara

#### **Description**

Queries the range of the aeronautical sensor in pressure units.

**Note:** If the instrument is not in aeronautical mode it returns an error: -221. Settings conflict.

---

## :SENS:ALT:SLEW

Applicability: PACE1000, PACE6000

### Command Syntax

#### SENSE:ALTitude:SLEW

Parameter: <string>

Short form: :SENS:ALT:SLEW

Function: Sets the rate set-point for altitude slew.

Default: -

### Query Syntax

#### SENSe:ALTitude:SLEW?

Short form: :SENS:ALT:SLEW?

Function: Queries the rate set-point for altitude slew.

Response: Decimal number representing the rate set-point for altitude slew (rate of climb) or (vertical speed) in current units.

### Description

This command sets the rate set-point for altitude slew. The query gets the rate set-point for altitude (rate of climb) or (vertical speed) per second or minute.

**Note:** If the instrument is not in aeronautical mode it returns an error: -221. Settings conflict.

### **:SENS:AIRF:QFE**

Applicability: PACE1000

#### **Command Syntax**

**n/a**

Parameter:

Short form:

Function:

#### **Query Syntax**

**SENSe:AIRField:QFE?**

Short form: :SENS:AIRF:QFE?

Function: This query reads the QFE value when the instrument is in airfield mode.

Response: A decimal reading in selected units of pressure.

#### **Description**

Queries the QFE reading, returns the QFE reading in selected units of pressure when the instrument is in airfield mode.

**Note:** QFE is the mean sea level pressure corrected for temperature and adjusted for a specific site (i.e. a datum such as an airfield).



---

## :SENS:AIRF:QFF

Applicability: PACE1000

### Command Syntax

n/a

Parameter:

Short form:

Function:

### Query Syntax

#### **SENSe:AIRField:QFF?**

Short form: :SENS:AIRF:QFF?

Function: This query reads the QFF value when the instrument is in airfield mode.

Response: A decimal reading in selected units of pressure.

### Description

Queries the QFF reading, returns the QFF reading in selected units of pressure when the instrument is in airfield mode.

**Note:** QFF is the mean sea level pressure derived from the barometric pressure calculated, assuming mean long term values of temperature and relative humidity, for a specific site. (i.e. the QFF is the location value plotted on the surface synoptic chart).

### **:SENS:AIRF:QNH**

Applicability: PACE1000

#### **Command Syntax**

**n/a**

Parameter:

Short form:

Function:

#### **Query Syntax**

**SENSe:AIRField:QNH?**

Short form: :SENS:AIRF:QNH?

Function: This query reads the QNH value when the instrument is in airfield mode.

Response: A decimal reading in selected units of pressure.

#### **Description**

Queries the QNH reading, returns the QNH reading in selected units of pressure when the instrument is in airfield mode.

**Note:** QNH is the pressure measured at a specific site then reduced to mean sea level pressure.

---

## **:SENS:MACH**

Applicability: PACE1000, PACE6000

### **Command Syntax**

**n/a**

Parameter:

Short form:

Function:

### **Query Syntax**

**SENSe:MACH?**

Short form: :SENS:MACH?

Function: This query reads the aeronautical sensors.

Response: A decimal reading in MACH number.

### **Description**

Queries the MACH reading.

**Note:** If the instrument is not in aeronautical mode it returns an error: -221. Settings conflict.

# :SENS:MACH:INL

Applicability: PACE6000

### Command Syntax

**:SENSe[x][:MACH]:INLimits <decimal>**

where x = 1 or 2 is the module number (default - 1)

Parameter: <decimal> MACH in limits value as % full-scale

Short form: :SENS:MACH:INL <decimal>

Function: The instrument has a MACH in-limits indicator. This can generate a service request when the MACH value is within limits for a set time period.

Default: 0.01% full-scale  
(Minimum: 0% full-scale)  
(Maximum: 100% full-scale)

### Query Syntax

**:SENSe[x][:MACH]:INLimits?**

where x = 1 or 2 is the module number (default - 1)

Short form: :SENS:MACH:INL?

Function: Query MACH in-limits value

Response: Decimal representing MACH in-limits value as % full-scale.

### Description

Sets the in-limits value.

**Note:** If the instrument is not in aeronautical mode it returns an error: -221. Settings conflict.

---

## :SENS:MACH:INL:TIME

Applicability: PACE6000

### Command Syntax

**:SENSe[x][:MACH]:INLimits:TIME <decimal>**

where x = 1 or 2 is the module number (default - 1)

Parameter: <integer> MACH in-limits time in seconds

Short form: :SENS:MACH:INL:TIME <decimal>

Function: Sets the time that the MACH value has to be within limits before generating a service request.

Default: 2 seconds  
(Minimum: 2 seconds)  
(Maximum: 999 seconds)

### Query Syntax

**:SENSe[x][:MACH]:INLimits:TIME?**

where x = 1 or 2 is the module number (default - 1)

Short form: :SENS:MACH:INL:TIME?

Function: Query MACH in-limits timers.

Response: Number representing MACH in-limits time in seconds.

### Description

Sets the MACH in-limits timer value.

**Note:** If the instrument is not in aeronautical mode it returns an error: -221. Settings conflict.

### **:SENS:MACH:RANG**

Applicability: PACE1000, PACE6000

#### **Command Syntax**

#### **SENSe[2]:MACH:RANG**

where x = 1 or 2 is the module number (default - 1)

Parameter:

Short form: :SENS:MACH:RANG

Function: Sets the MACH range

#### **Query Syntax**

#### **SENSe:MACH:SLEW?**

Short form: :SENS:MACH:RANG?

Function: This queries the MACH range.

Response: A string (number), representing MACH range.

#### **Description**

Queries the MACH range reading.

**Note:** If the instrument is not in aeronautical mode it returns an error: -221. Settings conflict.

---

## **:SENS:MACH:SLEW**

Applicability: PACE1000, PACE6000

### **Command Syntax**

#### **SENSe[2]:MACH:SLEW**

where x = 1 or 2 is the module number (default - 1)

Parameter: -

Short form: :SENS:MACH:SLEW

Function: Sets the rate set-point for MACH slew.

### **Query Syntax**

#### **SENSe:MACH:SLEW?**

Short form: :SENS:MACH:SLEW?

Function: Queries the rate set-point for MACH slew.

Response: A decimal, pressure reading/second in MACH.

### **Description**

This command sets the rate set-point for MACH slew. The query gets the rate set-point for MACH.

**Note:** If the instrument is not in aeronautical mode it returns an error: -221. Settings conflict.

# :SENS:PRES

Applicability: PACE1000, PACE5000, PACE6000

### Command Syntax

n/a

Parameter:

Short form:

Function:

### Query Syntax

**:SENSe[:PRESSure]?**

where x = 1 or 2 is the module number (default - 1)

Short form: :SENS?

Function: This query reads the sensor which has been selected by the :SENS:PRES:RANG command.

Response: A decimal, pressure reading in the current units.

### Description

Queries the pressure reading for the selected sensor in the selected units. The sensor selected can be changed using the :SENSe[:PRESSure]:RANGe command. PACE5000 and PACE6000 for alternative query to :SENS:PRES? that does not require preselection of the sensor using the :SENS:PRES:RANG command refer to :SENS:PRESS:BAR, :SENS:PRES:CONT, :SENS:PRES:PSE and :SENS:PRES:REF and to directly query the pressure values of the +ve and -ve pressure supply source and vacuum sensors refer to the :SOUR:PRES:COMP query.

### Example:

```
TX> :SENS1:PRES?           TX> :SENS2:PRES:RANG?
RX> :SENS:PRES 3616.9282227 RX> :SENS2:PRES:RANG "3.50barg"
TX> :SENS2:PRES?           Currently module 2 sensing range is in gauge mode.
RX> :SENS2:PRES 3617.1921387 TX> :SENS2:PRES:RANG "4.50bara"
TX> :SENS2:PRES:RANG?
RX> :SENS2:PRES:RANG "4.50bara"
It has been changed to pseudo-absolute mode.
```

```
TX> :SENS2:PRES?
RX> :SENS2:PRES 4615.0807447
```

The reading is also changed to pseudo-absolute mode.

**Note:** :SOURe[:PRESSure]:RANGe command does not change 'SENS?' reading. It changes the front-panel display.



---

## **:SENS:PRES:AVER**

Applicability: PACE1000

### **Command Syntax**

**:SENSe[:PRESsure]:AVERage**

Parameter:

Short form: :SENS:AVE

Function: Enables current average pressure value to be sent.

### **Query Syntax**

**:SENSe[:PRESsure]:AVERage?**

Short form: :SENS:AVE?

Function: Query average pressure value

Response: Current average pressure value.

### **Description**

This command query gets the average pressure value and the current pressure units.

# **:SENS:PRES:AVER:RES**

Applicability: PACE1000

### **Command Syntax**

**:SENSe[:PRESsure]:AVERage:RESet**

Parameter:

Short form: :SENS:AVE:RES

Function: Resets average, minimum and maximum pressure readings.

### **Query Syntax**

**n/a**

Short form:

Function:

Response:

### **Description**

This command resets the maximum, average and minimum pressure readings.

---

## **:SENS:PRES:AVER:TIME**

Applicability: PACE1000

### **Command Syntax**

**:SENSe[:PRESsure]:AVERage:TIME**

Parameter:

Short form: :SENS:AVE:TIME

Function: Sets the averaging function time period.

### **Query Syntax**

**n/a**

Short form:

Function:

Response:

### **Description**

This command sets the averaging function time period.

# **:SENS:PRES:CONT**

Applicability: PACE5000, PACE6000

### **Command Syntax**

**n/a**

Parameter:

Short form:

Function:

### **Query Syntax**

**:SENSe[x][:PRESsure]:CONTrol?**

where x = 1 or 2 is the module number (default - 1)

Normal form: :SENS:PRES:CONT?

Function: Queries the selected module control sensor pressure value.

Response: <decimal> in the selected units of pressure measurement.

### **Description**

Returns the selected module pressure measured by the control transducer. An alternative query to :SENS:PRES? that does not require preselection of the sensor using the :SENS:PRES:RANG command. To directly query the pressure values of the +ve and -ve pressure supply source and vacuum sensors refer to the :SOUR:PRES:COMP query.

### **Example:**

TX> :SENS:PRES:CONT?

RX> :SENS:PRES:CONT 982.8430904 (this value in mbar).

## :SENS:PRES:INL

Applicability: PACE5000, PACE6000

### Command Syntax

n/a

Parameter:

Short form:

Function:

### Query Syntax

#### :SENSe[x][:PRESsure]:INLimits?

where x = 1 or 2 is the module number (default - 1)

Short form: :SENS:INL?

Function: Query in-limits value

Response: First parameter - current pressure.

Second parameter - in limit:

0 = not in limits

1 = in limits

### Description

This command query gets the in-limits value and the in-limits status:

#### Example 1:

```
TX> :SENS:PRES:INL?
```

```
RX> :SENS:PRES:INL 990.0527344, 0
```

#### Example 2:

```
TX> :SENS:PRES:INL?
```

```
RX> :SENS:PRES:INL 990.0527344, 1
```

### **:SENS:PRES:INL:TIME**

Applicability: PACE5000, PACE6000

#### **Command Syntax**

n/a

Parameter:

Short form:

Function:

#### **Query Syntax**

**:SENSe[x][:PRESsure]:INLimits:TIME?**

where x = 1 or 2 is the module number (default - 1)

Short form: :SENS:PRES:INL:TIME?

Function: Query pressure in-limits timers.

Response: Number representing the in-limits time value since last set-point entry or controller Measure to Control state.

#### **Description**

Sets the pressure in-limits timer value.

---

## **:SENS:PRES:SLEW**

Applicability: PACE1000, PACE5000, PACE6000

### **Command Syntax**

**n/a**

Parameter:

Short form:

Function:

### **Query Syntax**

**:SENSe[x][:PRESsure]:SLEW?**

where x = 1 or 2 is the module number (default - 1)

Short form: :SENS:SLEW?

Function: Asks for current slew rate.

Response: Decimal number representing the measured slew rate always in current pressure units per current time setting (/s or /m).

### **Description**

This query gets the slew rate of the input pressure always in current pressure units per current time setting (/s or /m).

### **Example 1:**

TX> :SENS:PRES:SLEW?

RX> :SENS:PRES:SLEW -20.1089802

### **Example 2:**

TX> :SENS2:PRES:SLEW?

RX> :SENS2:PRES:SLEW -20.0536633

# **:SENS:PRES:BAR**

Applicability: PACE1000, PACE5000, PACE6000

### **Command Syntax**

**n/a**

Parameter:

Short form:

Function:

### **Query Syntax**

**:SENSe[x][:PRESsure]:BARometer?**

where x = 1 or 2 is the module number (default - 1)

Short form: :SENS:BAR?

Function: Queries the barometric pressure value.

Response: <decimal> in the selected units of pressure measurement.

### **Description**

Returns the selected module barometric pressure measured by the optional barometric transducer. If the optional barometric transducer is not fitted, the response is zero pressure. PACE5000 and PACE6000 alternative query to :SENS:PRES? that does not require preselection of the sensor using the :SENS:PRES:RANG command. To directly query the pressure values of the +ve and -ve pressure supply source and vacuum sensors refer to the :SOUR:PRES:COMP query.

### **Example:**

TX> :SENS:PRES:BAR?

RX> :SENS:PRES:BAR 982.8430904 (this value in mbar).



# :SENS:PRES:RANG

Applicability: PACE1000, PACE5000, PACE6000

## Command Syntax

**:SENSe[x][:PRESsure]:RANGe <string>**

where x = 1 = module 1 or x = 2 = module 2 (if x is blank the default is module 1)

Parameter: <string> range information

Short form: :SENS:RANG

Function: Selects an internal range.

## Query Syntax

**:SENSe[x][:PRESsure]:RANGe?**

where x = 1 = module 1 or x = 2 = module 2 (if x is blank the default is module 1)

Short form: :SENS:RANG?

Function: Asks for currently sensed range.

Response: A string (number), representing the selected pressure range in pressure units.

Example: 3.50 barg

## Description

This command selects an internal pressure range for use by the :SENS[x]:PRES? query to return a displayed or non-displayed pressure reading, and also in calibration mode for selecting the sensor to be calibrated. This command does not affect the pressure range selected for pressure control and measured pressure display purposes, nor does it affect the pressure control function.

Refer to :SOUR:PRES:RANG to change the range used for pressure control and measured pressure display.

Tx	Rx	Remarks
:INST:CAT2:ALL?	:INST:CAT2:ALL "3.50barg","BAROMETER","4.50bara"	Shows module 2 has three ranges.
:SENS2:PRES:RANG?	:SENS2:PRES:RANG "3.50barg"	Queries the current range selected by module 2.
:SENS:PRES:RANG "4.50bara"	None	Selects a different range of module 2 use the command.
:SENS2:PRES:RANG?	:SENS2:PRES:RANG "4.50bara"	Shows the 4.50bara range is selected.

**Note:** The command parameter, "4.50bara", has to be typed exactly as returned by the :INST:CAT:ALL? command. It is case-sensitive and not typo-error tolerant. The command does not affect the front-panel display only the internal. Use :SOUR:PRES:RANG to change front-panel range display. (See instrument user's manual).

# :SENS:PRES:RES

Applicability: PACE1000, PACE5000, PACE6000

### Command Syntax

**:SENSe[x][:PRESsure]:RESolution <string>**

where x = 1 or 2 is the module number (default - 1)

Parameter: <integer> resolution information

Short form: :SENS:RES

Function: Used to select a resolution to be used.

### Query Syntax

**:SENSe[x][:PRESsure]:RESolution?**

where x = 1 or 2 is the module number (default - 1)

Short form: :SENS:RES?

Function: Asks for current resolution.

Response: An integer from 4 to 7 representing selected resolution.

### Description

This command selects the resolution to be used for showing the pressure reading in the front panel display.

**Example 1:** TX> :SENS:PRES:RES?

RX> :SENS:PRES:RES 6

The resolution can be changed by the command, such as:

TX> :SENS:PRES:RES 4

**Example 2:** Query again confirms that the resolution has been changed to '4' :

TX> :SENS:PRES:RES?

RX> :SENS:PRES:RES 4

**Example 3:** Any resolution number outside the 4 to 7 boundary generates error messages, such as:

TX> :SENS2:PRES:RES 8

TX> :SYST:ERR?

RX> :SYST:ERR -222,"Data out of range; Parameter 1"

TX> :SENS2:PRES:RES 3

TX> :SYST:ERR?

RX> :SYST:ERR -222,"Data out of range; Parameter 1"

## :SENS:PRES:CORR:HEAD

Applicability: PACE1000, PACE5000, PACE6000

### Command Syntax

**:SENSe[x][:PRESsure]:CORRection:HEAD <enumerated>,<decimal>**

where x = 1 or 2 is the module number (default - 1)

Parameter:	<enumerated>	AIR - Air used as gas NITRogen - Nitrogen used as gas
	<numeric>	Height of gas in metres.
Short form:	:SENS:CORR:HEAD <enumerated>,<numeric>	
Function:	Head correction parameters.	
Default	Enumerated	AIR
	Decimal	0

### Query Syntax

**:SENSe[x][:PRESsure]:CORRection:HEAD?**

where x = 1 or 2 is the module number (default - 1)

Short form:	:SENS:CORR:HEAD?
Function:	Query gas and height of head correction.
Response:	AIR/NITRogen and height in metres (+100 to -100).

### Description

A correction must be made if the unit under test is at a different height from the instrument. This command programs the gas used and the height difference.

**Example 1:** TX> :SENS:PRES:CORR:HEAD?

RX> :SENS:PRES:CORR:HEAD AIR, -0.7500000

**Example 2:** Head correction can be set to a new height by the command:

TX> :SENS:PRES:CORR:HEAD AIR, 1.2

**Example 3:** Another query will confirm the height change:

TX> :SENS:PRES:CORR:HEAD?

RX> :SENS:PRES:CORR:HEAD AIR, 1.2000000

**Example 4:** Head correction can be set for another gas by:

TX> :SENS:PRES:CORR:HEAD NITROGEN, 1.2

**Example 5:** Another query will confirm the height change:

TX> :SENS:PRES:CORR:HEAD?

RX> :SENS:PRES:CORR:HEAD NITR, 1.2000000

**Note:** NITROGEN or NITR is an enumerated data type (not in punctuation marks), not a string and is not case-sensitive and can have a short form.

# **:SENS:PRES:CORR:HEAD:STAT**

Applicability: PACE1000, PACE5000, PACE6000

### **Command Syntax**

**:SENSe[x][:PRESsure]:CORRection:HEAD:STATe <Boolean>**

where x = 1 or 2 is the module number (default - 1)

Parameter: <boolean>  
0 - Disables head correction  
1 - Enables head correction

Short form: :SENS:CORR:HEAD:STAT <Boolean>

Function: Enables/disables head correction.

Default: 0

### **Query Syntax**

**:SENSe[x][:PRESsure]:CORRection:HEAD:STATe?**

where x = 1 or 2 is the module number (default - 1)

Short form: :SENS:CORR:HEAD:STAT?

Function: Query head correction state

Response: 0 - head correction off  
1 - head correction on

### **Description**

This command enables or disables the head correction compensation.

### **Example:**

TX> :SENS:PRES:CORR:HEAD:STATe?

RX> :SENS:PRES:CORR:HEAD:STAT 0

Head correction off

It can be turned on and off by:

TX> :SENS:PRES:CORR:HEAD:STATe on

TX> :SENS:PRES:CORR:HEAD:STATe off

Or by:

TX> :SENS:PRES:CORR:HEAD:STATe 1

TX> :SENS:PRES:CORR:HEAD:STATe 0

## :SENS:PRES:CORR:OFFS

Applicability: PACE1000, PACE5000, PACE6000

### Command Syntax

**:SENSe[x][:PRESsure]:CORRection:OFFSet**

where x = 1 or 2 is the module number (default - 1)

Parameter: <decimal> tare offset value in current pressure units.

Short form: :SENS:OFFS

Function: Subtracts the offset value from the processed reading.

Default: 0

### Query Syntax

**:SENSe[x][:PRESsure]:CORRection:OFFSet?**

where x = 1 or 2 is the module number (default - 1)

Short form: :SENS:OFFS?

Function: Asks for the tare value.

Response: Number corresponding to the tare offset value.

### Description

#### Example:

TX> :SENS:PRES:CORR:OFFS?

RX> :SENS:PRES:CORR:OFFS 0.0

Offset is zero.

Offset can be changed to 100 mbar by sending, (instrument must be in mbar):

TX> :SENS:PRES:CORR:OFFS 100

Send query again to confirm offset has changed:

TX> :SENS:PRES:CORR:OFFS?

RX> :SENS:PRES:CORR:OFFS 100.0000000

**Note:** The offset depends on the units of measurement used by the instrument. If changed from mbar to bar, the same query will be returned:

TX> :SENS:PRES:CORR:OFFS?

RX> :SENS:PRES:CORR:OFFS 0.1000000

### **:SENS:PRES:CORR:OFFS:STAT**

Applicability: PACE1000, PACE5000, PACE6000

#### **Command Syntax**

**:SENSe[x][:PRESsure]:CORRection:OFFSet:STATe**

where x = 1 or 2 is the module number (default - 1)

Parameter: <boolean>  
0 - disables offset  
1 - enables offset

Short form: :SENS:OFFS:STAT

Function: Enables and disables the offset function.

#### **Query Syntax**

**:SENSe[x][:PRESsure]:CORRection:HEAD:OFFSet:STATe?**

where x = 1 or 2 is the module number (default - 1)

Short form: :SENS:OFFS:STAT?

Function: Asks if offset function is on or off.

Response: 1 (on)  
0 (off)

#### **Description**

This command enables and disables the offset function. The query gets the state of the offset (or tare) on or off.

#### **Example:**

:SENS:PRES:CORR:OFFS:STATe

TX> :SENS:PRES:CORR:OFFS:STATe?

RX> :SENS:PRES:CORR:OFFS:STAT 0

The offset correction disabled.

Offset can be enabled and disabled by sending:

TX> :SENS:PRES:CORR:OFFS:STATe on

TX> :SENS:PRES:CORR:OFFS:STATe off

Or by:

TX> :SENS:PRES:CORR:OFFS:STATe 1

TX> :SENS:PRES:CORR:OFFS:STATe 0

---

## **:SENS:PRES:CORR:VOL**

Applicability: PACE5000, PACE6000

### **Command Syntax**

**n/a**

Parameter:

Short form:

Function:

### **Query Syntax**

**:SENSe[x][:PRESsure]:CORRection:VOLume?**

where x = 1 or 2 is the module number (default - 1)

Short form: :SENS:PRES:CORR:VOL?

Function: Ask for the estimated volume of the system connected to the instrument.

Response: Decimal number in litres corresponding to volume.

### **Description**

The instrument calculates and reports the volume of the system connected.

### **Example:**

TX> :SENS:PRES:CORR:VOL?

RX> :SENS:PRES:CORR:VOL 0.0150000

### **:SENS:PRES:FILT:LPAS:BAND**

Applicability: PACE1000, PACE5000, PACE6000

#### **Command Syntax**

**:SENSe[x][:PRESsure]:FILTer:[LPASs]:BAND <decimal>**

where x = 1 or 2 is the module number (default - 1)

Parameter: <decimal> filter band response value in % full-scale.

Short form: :SENS:FILT:BAND

Function: Used to set-up the response band component of the filter.

Default: 0  
(Minimum: 0)  
(Maximum: 100.0)

#### **Query Syntax**

**:SENSe[x][:PRESsure]:FILTer:[LPASs]:BAND?**

where x = 1 or 2 is the module number (default - 1)

Short form: :SENS:FILT:BAND?

Function: Ask for filter step response band parameter.

Response: Number corresponding to filter step response value in % full-scale.

#### **Description**

The digital low pass filter has a response band configured as percentage of full-scale. e.g., defaults to 0.05% FS. If the reading has changed by more than the configured band response value then the filtering is ignored for that conversion and the pressure goes instantly to the new value.

#### **Example:**

TX> :SENS:PRES:FILT:LPAS:BAND?

RX> :SENS:PRES:FILT:LPAS:BAND 50.0000000

The current setting for the filter band is 50% of full-scale, i.e., the filter applies only when the change of pressure is within this band.

It can be changed to another number, (for example: 12% of full-scale), by sending:

TX> :SENS:PRES:FILT:LPAS:BAND 12

TX> :SENS:PRES:FILT:LPAS:BAND?

RX> :SENS:PRES:FILT:LPAS:BAND 12.0000000



## :SENS:PRES:FILT:LPAS:FREQ

Applicability: PACE1000, PACE5000, PACE6000

### Command Syntax

**:SENSe[x][:PRESsure]:FILTer:[LPASs]:FREQuency <decimal>**

where x = 1 or 2 is the module number (default - 1)

Parameter: <decimal> filter averaging time in seconds.

Short form: :SENS:FILT:FREQ

Function: Used to set up the averaging component of the filter.

Default: 0  
(Minimum: 0)  
(Maximum: 20)

### Query Syntax

**:SENSe[x][:PRESsure]:FILTer:[LPASs]:FREQuency?**

where x = 1 or 2 is the module number (default - 1)

Short form: :SENS:FILT:FREQ?

Function: Ask for filter average parameter.

Response: Decimal number corresponding to filter average time in seconds.

### Description

A digital low pass filter can be applied to the pressure reading. This is a first order low pass filter, the time constant depends on the value set by this command.

**Note:** The decimal number used by the command and query does not represent frequency even though 'FREQ' is used.

### Example:

TX> :SENS:PRES:FILT?

RX> :SENS:PRES:FILT:LPAS:STAT 0

It can be set to another value, such as:

TX> :SENS:PRES:FILT:LPAS:FREQ 1.76

TX> :SENS:PRES:FILT:LPAS:FREQ?

RX> :SENS:PRES:FILT:LPAS:FREQ 1.7600000

Query the current setting for low-pass filter's time constant, returned value is 2 seconds.

TX> :SENS:PRES:FILT:LPAS:FREQ?

RX> :SENS:PRES:FILT:LPAS:FREQ 2.0000000

### **:SENS:PRES:FILT:LPAS:STAT**

Applicability: PACE1000, PACE5000, PACE6000

#### **Command Syntax**

**:SENSe[x][:PRESsure]:FILTer[:LPASs]:[STATE] <Boolean>**

Parameter: <Boolean>  
0 - Disables low pass filter  
1 - Enables low pass filter

Short form: :SENS:PRES:FILT <Boolean>

Function: Sets low pass filter ON or OFF.

Default: OFF

#### **Query Syntax**

**:SENSe[x][:PRESsure]:FILTer[:LPASs]:[STATE]?**

where x = 1 or 2 is the module number (default - 1)

Short form: :SENS:PRES:FILT?

Function: Query state (on or off) for the low pass filter

Response: 1 (ON) 0 (OFF)

#### **Description**

This command is used to enable or disable the low pass filter for producing a more stable reading. An 'intelligent' filter is implemented so that any noise in the system is filtered while step changes pass straight through the filter.

#### **Example:**

```
TX> :SENS:PRES:FILT:LPAS:STAT?
RX> :SENS:PRES:FILT:LPAS:STAT 0
The filter is currently off.
It can be set on and off by
TX> :SENS:PRES:FILT:LPAS:STAT on
TX> :SENS:PRES:FILT:LPAS:STAT off
Or by
TX> :SENS:PRES:FILT:LPAS:STAT 1
TX> :SENS:PRES:FILT:LPAS:STAT 0
```

---

## **:SENS:PRES:MAX**

Applicability: PACE1000

Command Syntax

**n/a**

Parameter:

Short form:

Function:

**Query Syntax**

**:SENSe:[PRESsure]:MAXimum?**

Short form: :SENS:MAX?

Function: This query reads the maximum pressure.

Response: A reading of the current set maximum pressure in selected pressure units.

**Description**

Queries the current maximum setting for pressure.

### **:SENS:PRES:MAX:RES**

Applicability: PACE1000

#### **Command Syntax**

**SENSe:[PRESsure]:MAXimum:RESet**

Parameter:

Short form: :SENS:MAX:RES

Function: Resets maximum, average and minimum pressure readings.

#### **Query Syntax**

**n/a**

Short form:

Function:

Response:

#### **Description**

Command resets the maximum, average and minimum pressure readings.

---

## **:SENS:PRES:MIN**

Applicability: PACE1000

### **Command Syntax**

**n/a**

Parameter:

Short form:

Function:

### **Query Syntax**

**SENSe:PRESSure:MINimum?**

Short form: :SENS:MIN?

Function: This query reads the minimum pressure.

Response: A reading of the current set minimum pressure in selected pressure units.

### **Description**

Queries the current minimum setting for pressure.

### **:SENS:PRES:MIN:RES**

Applicability: PACE1000

#### **Command Syntax**

**SENSe:[PRESsure]:MINimum:RESet**

Parameter:

Short form: :SENS:MIN:RES

Function: Resets minimum, average and maximum pressure readings.

#### **Query Syntax**

**n/a**

Short form:

Function:

Response:

#### **Description**

This command resets minimum, average and maximum pressure readings.

---

## **:SENS:PRES:PERC**

Applicability: PACE1000

### **Command Syntax**

**n/a**

Parameter:

Short form:

Function:

### **Query Syntax**

**SENSe:[PRESsure]:PERCent?**

Short form: :SENS:PERC?

Function: This query reads the percentage pressure.

Response: A reading of the current set percentage pressure.

### **Description**

Queries the current percentage pressure reading.

### **:SENS:PRES:PERC:SPAN**

Applicability: PACE1000

#### **Command Syntax**

**SENSe:[PRESsure]:PERCent:SPAN**

Parameter: NONE|FS|SPAN

Short form: SENS:PERC:SPAN

Function: Sets the percentage span.

#### **Query Syntax**

**SENSe:[PRESsure]:PERCent:SPAN?**

Short form: SENS:PERC:SPAN?

Function: This query reads the percentage span.

Response: A reading of the current set percentage span.

#### **Description**

Sets the percentage span: NONE|FS|SPAN. Queries the current percentage span setting.



---

## **:SENS:PRES:PERC:STAT**

Applicability: PACE1000

### **Command Syntax**

**n/a**

Parameter:

Short form:

Function:

### **Query Syntax**

**SENSe:[PRESsure]:PERCent:STATe?**

Short form: :SENS:PERC:STAT?

Function: This query reads the percentage state.

Response: NONE|FS|SPAN

### **Description**

Queries the current percentage state instrument returns NONE or FS or SPAN.

# **:SENS:PRES:PSE**

Applicability: PACE5000 and PACE6000

### **Command Syntax**

**n/a**

Parameter:

Short form:

Function:

### **Query Syntax**

**:SENSe[x][:PRESsure]:PSE?**

where x = 1 or 2 is the module number (default - 1)

Normal form: :SENS:PRES:PSE?

Function: Queries the selected module pseudo range pressure value.

Response: <decimal> in the selected units of pressure measurement.

### **Description**

Returns the selected module pseudo range pressure value. An alternative query to :SENS:PRES? that does not require preselection of the control sensor using the :SENS:PRES:RANG command. To directly query the pressure values of the +ve and -ve pressure supply source and vacuum sensors refer to the :SOUR:PRES:COMP query.

### **Example:**

TX> :SENS:PRES:PSE?

RX> :SENS:PRES:PSE 982.8430904 (this value in mbar).

---

## **:SENS:PRES:REF**

Applicability: PACE5000 and PACE6000 CM3 modules only

### **Command Syntax**

**n/a**

Parameter:

Short form:

Function:

### **Query Syntax**

**:SENSe[x][:PRESsure]:REF?**

where x = 1 or 2 is the module number (default - 1)

Normal form: :SENS:PRES:REF?

Function: Queries the selected module reference sensor pressure value.

Response: <decimal> in the selected units of pressure measurement.

### **Description**

Returns the selected module reference sensor pressure value. An alternative query to :SENS:PRES? that does not require preselection of the sensor using the :SENS:PRES:RANG command. To directly query the pressure values of the +ve and -ve pressure supply source and vacuum sensors refer to the :SOUR:PRES:COMP query.

### **Example:**

TX> :SENS:PRES:REF?

RX> :SENS:PRES:REF 982.8430904 (this value in mbar).

### **:SENS:SPE**

Applicability: PACE1000, PACE6000

#### **Command Syntax**

n/a

Parameter:

Short form:

Function:

#### **Query Syntax**

**:SENSe:SPEEd?**

Short form: :SENS:SPE?

Function: This query reads the aeronautical sensors.

Response: A decimal reading in currently selected airspeed units.

#### **Description**

Queries the airspeed reading.

**Note:** If the instrument is not in aeronautical mode it records an error: -221. Settings conflict.

## :SENS:SPE:INL

Applicability: PACE6000

### Command Syntax

**:SENSe[x][:SPEed]:INLimits <decimal>**

where x = 1 or 2 is the module number (default - 1)

Parameter: <decimal> airspeed in limits value as % full-scale

Short form: :SENS:SPE:INL <decimal>

Function: The instrument has a airspeed in-limits indicator. This can generate a service request when the airspeed value is within limits for a set time period.

Default: 0.01% full-scale  
(Minimum: 0% full-scale)  
(Maximum: 100% full-scale)

### Query Syntax

**:SENSe[x][:SPEed]:INLimits?**

where x = 1 or 2 is the module number (default - 1)

Short form: :SENS:SPE:INL?

Function: Query airspeed in-limits value

Response: Decimal representing airspeed in-limits value as % full-scale.

### Description

Sets the in-limits value.

**Note:** If the instrument is not in aeronautical mode it records an error: -221. Settings conflict.

# **:SENS:SPE:INL:TIME**

Applicability: PACE6000

### **Command Syntax**

**:SENSe[x][:SPEed]:INLimits:TIME <decimal>**

Parameter: <integer> airspeed in-limits time in seconds

Short form: :SENS:SPE:INL:TIME <decimal>

Function: Sets the time that the airspeed value has to be within limits before generating a service request.

Default: 2 seconds  
(Minimum: 2 seconds)  
(Maximum: 999 seconds)

### **Query Syntax**

**:SENSe[x][:SPEed]:INLimits:TIME?**

where x = 1 or 2 is the module number (default - 1)

Short form: :SENS:SPE:INL:TIME?

Function: Query airspeed in-limits timers.

Response: Number representing airspeed in-limits time in seconds.

### **Description**

Sets the airspeed in-limits timer value.

**Note:** If the instrument is not in aeronautical mode it records an error: -221. Settings conflict.

---

## :SENS:SPE:RANG

Applicability: PACE1000, PACE6000

### Command Syntax

#### :SENSe[2]:SPEed:RANGe

where x = 1 or 2 is the module number (default - 1)

Parameter:

Short form: :SENS:SPE:RANG

Function: Sets the airspeed range.

### Query Syntax

#### :SENSe:SPEed:SLEW?

Short form: :SENS:SPE:RANG?

Function: This query reads the airspeed range.

Response: A string (number), representing the airspeed range in pressure units.  
Example: 3.50 barg

### Description

Queries the airspeed range.

**Note:** If the instrument is not in aeronautical mode it records an error: -221. Settings conflict.

### **:SENS:SPE:SLEW**

Applicability: PACE1000, PACE6000

#### **Command Syntax**

#### **:SENSe[2]:SPEed:SLEW**

where x = 1 or 2 is the module number (default - 1)

Parameter:

Short form: :SENS:SPE:SLEW

Function: Sets the airspeed rate of change.

#### **Query Syntax**

#### **:SENSe:SPE:SLEW?**

Short form: :SENS:SPE:SLEW?

Function: This query reads the airspeed rate of change.

Response: A decimal, airspeed reading/second.

#### **Description**

Queries the airspeed rate of change reading.

**Note:** If the instrument is not in aeronautical mode it records an error: -221. Settings conflict.



---

## SOURce

The SOURce subsystem controls the pressure output of the instrument.

### :SOUR:ALT

Applicability: PACE6000

#### Command Syntax

#### :SOURce:ALTitude:LEVel:IMMediate:AMPLtude

Parameter: <string>

Short form: :SOUR:ALT

Function: Sets the altitude set-point.

Default: -

#### Query Syntax

#### :SOURce:ALTitude:LEVel:IMMediate:AMPLtude?

Short form: :SOUR:ALT?

Function: Queries altitude set-point.

Response: Decimal number representing altitude in current units.

#### Description

This command sets the altitude set-point. This query gets the decimal number representing altitude in current units.

**Note:** If the instrument is not in aeronautical mode it returns an error: -221. Settings conflict.

# **:SOUR:MACH:REF**

Applicability: PACE6000

### **Command Syntax**

**n/a**

Parameter:

Short form:

Function:

### **Query Syntax**

**:SOURce:MACH:REFerence?**

Short form: :SOUR:MACH:REF

Function: Queries the MACH reference value from either Ps reference or barometric.

Response: Decimal number representing the MACH reference value in currently selected pressure units.

### **Description**

The query gets the MACH reference value in currently selected pressure units.

**Note:** If the instrument is not in aeronautical mode it returns an error: -221. Settings conflict.

---

## **:SOUR:MACH:REF:MODE**

Applicability: PACE6000

### **Command Syntax**

#### **:SOURce:MACH:REFerence:MODE**

Parameter: <decimal>

Short form: :SOUR:MACH:REF:MODE

Function: Enables a MACH reference mode to be set.

Default: -

### **Query Syntax**

#### **:SOURce:MACH:REFerence:MODE?**

Short form: :SOUR:MACH:REF:MODE?

Function: Queries the MACH reference mode.

Response: Numeric value representing the MACH reference mode.

### **Description**

This command enables a MACH reference mode to be set. The query gets the MACH reference entered mode.

**Note:** If the instrument is not in aeronautical mode it returns an error: -221. Settings conflict.

### **:SOUR:MACH:REF:VAL**

Applicability: PACE6000

#### **Command Syntax**

##### **:SOURce:MACH:REFerence:VALue**

Parameter: <string>

Short form: :SOUR:MACH:REF:VAL

Function: Sets the MACH reference entered value.

Default: -

#### **Query Syntax**

##### **:SOURce:MACH:REFerence:VALue?**

Short form: :SOUR:MACH:REF:VAL?

Function: Queries the MACH reference entered value from either Ps reference.

Response: Numeric value of the MACH reference.

#### **Description**

This command sets the MACH reference entered value from either Ps reference. The query gets the MACH reference entered value.

**Note:** If the instrument is not in aeronautical mode it returns an error: -221. Settings conflict.

---

## **:SOUR:MACH:LEV:IMM:AMPL**

Applicability: PACE6000

### **Command Syntax**

**:SOURce[x]:MACH[:LEVel][:IMMediate][:AMPLitude] <decimal>**

where x = 1 or 2 is the module number (default - 1)

Parameter: <decimal> in MACH number.

Short form:

Function: Sets the MACH set-point

Default: 0.0

### **Query Syntax**

**:SOURce[x]:MACH[:LEVel][:IMMediate][:AMPLitude] <decimal>?**

Short form:

Function: Programmable set-point value

Response: Decimal number representing the set-point in MACH number.

### **Description**

This command sets the MACH set-point. This query gets the decimal number representing the set-point in MACH number.

**Note:** If the instrument is not in aeronautical mode it returns an error: -221. Settings conflict.

# :SOUR:PRES:COMP

Applicability: PACE5000, PACE6000

### Command Syntax

n/a

Parameter:

Short form:

Function:

### Query Syntax

**:SOURce[x][:PRESsure]:COMPensate[y]?**

where: x (module) = 1 or 2 (default - 1) y (+ve or -ve source pressure) = 1 or 2.

Short form: :SOUR:COMP?

Function: Queries the +ve or the -ve supply source pressure sensor.

Response: Pressure value in current pressure units.

### Description

Returns the +ve and -ve source pressure values in the current pressure units. An alternative query to :SENS:PRES? that does not require preselection of the sensor using the :SENS:PRES:RANG command. Refer to :SENS:PRESS:BAR, :SENS:PRES:CONT, :SENS:PRES:PSE and :SENS:PRES:REF

y	Source Pressure Measurement
1	+ve
2	-ve

### Example:

TX> :SOUR:PRES:COMP?

RX> :SOUR:PRES:COMP 3165.9526002

TX> :SOUR:PRES:COMP1?

RX> :SOUR:PRES:COMP 3165.9484591

TX> :SOUR:PRES:COMP2?

RX> :SOUR:PRES:COMP2 -963.9638062

If x is greater than 2, an error will be reported

TX> :SOUR:PRES:COMP3?

TX> :SYST:ERR?

RX> :SYST:ERR -114,"Header suffix out of range"

## :SOUR:PRES:EFF

Applicability: PACE5000, PACE6000

### Command Syntax

n/a

Parameter:

Short form:

Function:

Default:

### Query Syntax

**:SOURce[x][:PRESsure]:EFFort?**

where x = 1 or 2 is the module number (default - 1)

Short form: :SOUR:EFF?

Function: This query only command returns the effort needed for the controller to achieve the set-point.

Response: Decimal percent number representing controller effort.

### Description

This query only command returns the % effort the controller does to achieve the set-point.

### Example:

```
TX> :SOUR:PRES:EFF?
```

```
RX> :SOUR:PRES:EFF -0.2342882
```

Percentage of effort the supply or vacuum valve makes to maintain the control point. The return number should be -100 to +100. A positive number indicates the supply valve makes more effort and a minus number indicates the vacuum valve makes more effort. If the controller is off:

```
TX> :OUTP off
```

```
TX> :SOUR:PRES:EFF?
```

```
RX> :SOUR:PRES:EFF 0.0
```

The return number is '0.0', since no valve is making any effort.

# :SOUR:PRES:INL

Applicability: PACE5000, PACE6000

### Command Syntax

**:SOURce[x][:PRESsure]:INLimits <decimal>**

where x = 1 or 2 is the module number (default - 1)

Parameter: <decimal> in limits value as % full-scale

Short form: :SOUR:INL <decimal>

Function: The controller has an in-limits set-point indicator. This can generate a service request when the pressure is within limits for a set time period.

Default: 0.01% full-scale  
(Minimum: 0.0001% full-scale)  
(Maximum: 10% full-scale)

### Query Syntax

**:SOURce[x][:PRESsure]:INLimits?**

where x = 1 or 2 is the module number (default - 1)

Short form: :SOUR:INL?

Function: Query in-limits value

Response: Decimal representing in-limits value as % full-scale.

### Description

Sets the in-limits value.

### Example:

```
TX> :SOUR:PRES:INL?
```

```
RX> :SOUR:PRES:INL 0.0200000
```

The current in-limits set-point is 0.02% full-scale.

Can be set to:

```
TX> :SOUR:PRES:INL 0.01
```

```
TX> :SOUR:PRES:INL?
```

```
RX> :SOUR:PRES:INL 0.0100000
```



## **:SOUR:PRES:INL:TIME**

Applicability: PACE5000, PACE6000

### **Command Syntax**

**:SOURce[x][:PRESsure]:INLimits:TIME <decimal>**

where x = 1 or 2 is the module number (default - 1)

Parameter: <integer> in-limits time in seconds

Short form: :SOUR:INL:TIME <decimal>

Function: Sets the time that the pressure has to be within limits before generating a service request.

Default: 1 second  
(Minimum: 1 second)  
(Maximum: 60 seconds)

### **Query Syntax**

**:SOURce[x][:PRESsure]:INLimits:TIME?**

where x = 1 or 2 is the module number (default - 1)

Short form: :SOUR:INL:TIME?

Function: Query in-limits timers.

Response: Number representing in-limits time in seconds.

### **Description**

Sets the in-limits timer value.

### **Example:**

TX> :SOUR:PRES:INL:TIME?

RX> :SOUR:PRES:INL:TIME 1

Can be set to 99 by issuing command:

TX> :SOUR:PRES:INL:TIME 9

TX> :SOUR:PRES:INL:TIME?

RX> :SOUR:PRES:INL:TIME 9

Or to 999 by issuing command:

TX> :SOUR:PRES:INL:TIME 59

TX> :SOUR:PRES:INL:TIME?

RX> :SOUR:PRES:INL:TIME 59

### **:SOUR:PRES:LEV:IMM:AMPL**

Applicability: PACE5000, PACE6000

#### **Command Syntax**

**:SOURce[x][:PRESsure][:LEVel][:IMMediate][:AMPLitude] <decimal>**

where x = 1 or 2 is the module number (default - 1)

Parameter: <decimal> Pressure in current units

Short form: :SOUR <decimal>

Function: Set the pressure set-point

Default: 0.0

#### **Query Syntax**

**:SOURce[x][:PRESsure][:LEVel][:IMMediate][:AMPLitude]?**

where x = 1 or 2 is the module number (default - 1)

Short form: :SOUR?

Function: Programmable set-point value

Response: Decimal number representing pressure set-point in current units.

#### **Description**

This command sets the pressure set-point and is the long form of :SOUR:PRES.

#### **Example:**

```
TX> :SOUR:PRES?
```

```
RX> :SOUR:PRES:LEV:IMM:AMPL 0.4000000
```

The current controller set-point is 0.4 of the current unit.

It can be set to another value, such as:

```
TX> :SOUR:PRES 0.5
```

```
TX> :SOUR:PRES?
```

```
RX> :SOUR:PRES:LEV:IMM:AMPL 0.5000000
```

## :SOUR:PRES:LEV:IMM:AMPL:VENT

Applicability: PACE5000, PACE6000

### Command Syntax

**:SOURce[x][:PRESsure][:LEVel][:IMMediate][:AMPLitude]:VENT<space>  
<Parameter>**

where x = 1 = module 1 or x = 2 = module 2 (if x is blank the default is module 1)

Parameter: <integer>  
0 - abort vent  
1 - start vent

Normal form: :SOUR[x]:PRES:LEV:IMM:AMPL:VENT <parameter>

Short form: :SOUR[x]:VENT <parameter>

Function: Vents the user system.

Default: 0

### Query Syntax

**:SOURce[x][:PRESsure][:LEVel][:IMMediate][:AMPLitude]:VENT?**

where x = 1 = module 1 or x = 2 = module 2 (if x is blank the default is module 1)

Normal form: :SOUR[x]:PRES:LEV:IMM:AMPL:VENT?

Short form: :SOUR[x]:VENT?

Function: Query status of vent.

Response: 0 - vent OK  
1 - vent in progress  
2 - vent completed

### Description

This command vents the user system; the command should be queried to get the status of the vent.

### Examples:

For an instrument switched on without any vent, a query:

TX> :SOUR:PRES:LEV:IMM:AMPL:VENT?

RX> :SOUR:PRES:LEV:IMM:AMPL:VENT 0 (a return of '0' indicates vent not in progress).

A vent can be started by sending:

TX> :SOUR:PRES:LEV:IMM:AMPL:VENT 1

Immediate query:

TX> :SOUR:PRES:LEV:IMM:AMPL:VENT?

RX> :SOUR:PRES:LEV:IMM:AMPL:VENT 1

A return of '1' indicates vent in progress

TX> :SOUR:PRES:LEV:IMM:AMPL:VENT?

RX> :SOUR:PRES:LEV:IMM:AMPL:VENT 1

## Chapter 4. Command and Query Summary

---

TX> :SOUR:PRES:LEV:IMM:AMPL:VENT?

RX> :SOUR:PRES:LEV:IMM:AMPL:VENT 1

TX> :SOUR:PRES:LEV:IMM:AMPL:VENT?

RX> :SOUR:PRES:LEV:IMM:AMPL:VENT 1

TX> :SOUR:PRES:LEV:IMM:AMPL:VENT?

RX> :SOUR:PRES:LEV:IMM:AMPL:VENT 1

Continuing queries return '1', until the vent finishes and a return of '2':

TX> :SOUR:PRES:LEV:IMM:AMPL:VENT?

RX> :SOUR:PRES:LEV:IMM:AMPL:VENT 2

TX> :SOUR:PRES:LEV:IMM:AMPL:VENT?

RX> :SOUR:PRES:LEV:IMM:AMPL:VENT 2

TX> :SOUR:PRES:LEV:IMM:AMPL:VENT?

RX> :SOUR:PRES:LEV:IMM:AMPL:VENT 2

TX> :SOUR:PRES:LEV:IMM:AMPL:VENT?

RX> :SOUR:PRES:LEV:IMM:AMPL:VENT 2

To abort the vent process, send:

TX> :SOUR:PRES:LEV:IMM:AMPL:VENT 0

---

## **:SOUR:PRES:LEV:IMM:AMPL:VENT:RATE**

Applicability: PACE5000, PACE6000

### **Command Syntax**

**:SOUR[x]:PRES:LEV:IMM:AMPL:VENT:RATE <decimal>**

where x = 1 = module 1 or x = 2 = module 2 (if x is blank the default is module 1)

Parameter: <decimal> slew rate in current pressure units per second.

Short form:

Function: Sets the controller vent slew rate.

Default: -

### **Query Syntax**

**:SOUR[x]:PRES:LEV:IMM:AMPL:VENT:RATE?**

where x = 1 = module 1 or x = 2 = module 2 (if x is blank the default is module 1)

Short form:

Function: Queries the controller vent slew rate.

Response: Decimal number representing slew rate always in current pressure units per second.

### **Description**

This command sets the controller vent slew rate denominator time units, (/s or /m). The current setting of the denominator units can also be queried.

This command allows the pressure slew rate during the vent process can be set slower or faster than the control slew rate.

## **:SOUR:PRES:LEV:IMM:AMPL:VENT:UNIT**

Applicability: PACE5000, PACE6000

### **Command Syntax**

**:SOUR[x]:PRES:LEV:IMM:AMPL:VENT:UNIT <integer>**

where x = 1 = module 1 or x = 2 = module 2 (if x is blank the default is module 1)

Parameter: <integer> controller vent slew rate denominator units, see table below.

Short form:

Function: Sets the controller vent slew rate denominator time units.

Default: -

### **Query Syntax**

**:SOUR[x]:PRES:LEV:IMM:AMPL:VENT:UNIT?**

where x = 1 = module 1 or x = 2 = module 2 (if x is blank the default is module 1)

Short form:

Function: Queries the controller vent slew rate denominator units.

Response: Returns an integer, see table below.

### **Description**

This command sets the controller vent slew rate denominator time units, (/s or /m). The current setting of the denominator units can also be queried.

<b>y</b>	<b>Remark</b>
0	rate/second
1	rate/minute

## :SOUR:PRES:RANG

Applicability: PACE5000, PACE6000

### Command Syntax

**:SOURce[x][:PRESsure]:RANGe<space><"string">**

where x = 1 = module 1 or x = 2 = module 2 (if x is blank the default is module 1)

Parameter: <string> range information

Short form: :SOUR:RANG

Function: Selects the control range.

### Query Syntax

**:SOURce[x][:PRESsure]:RANGe?**

where x = 1 = module 1 or x = 2 = module 2 (if x is blank the default is module 1)

Normal form: :SOUR[x]:PRES:RANG?

Short form: :SOUR[x]:RANG?

Function: Asks for currently selected control module range.

Response: String representing selected sense range.

### Description

This command selects the range to be used for controlling pressure.

e.g. :SOUR:PRES:RANG "2.0bara"

selects the 2 bar absolute range; the pressure units are always in bar.

**Note:** Absolute ranges can be true absolute or pseudo-absolute ranges. Gauge ranges can be true gauge ranges or pseudo-gauge ranges, refer to commands ":INST:CAT:ALL?" and ":INST:CONTx:SENSy?".

### Example:

TX> :SOUR:PRES:RANG?

RX> :SOUR:PRES:RANG "3.50barg"

Queries module 1 current displayed measure and control range.

Sets module 2 to another range and then queries the current range selected:

TX> :SOUR2:PRES:RANG "4.50bara"

TX> :SOUR2:PRES:RANG?

RX> :SOUR2:PRES:RANG "4.50bara"

Changes are observed on front panel display. The string parameter is case sensitive.

# **:SOUR:PRES:RANG:LOW**

Applicability: PACE5000, PACE6000

### **Command Syntax**

**n/a**

Parameter:

Short form:

Function:

Default:

### **Query Syntax**

**:SOURce[x]:PRESsure:RANGe:LOW?**

where x = 1 or 2 is the module number (default - 1)

Short form: :SOUR:LOW?

Function: Queries the lower full-scale of the module [x].

Response: Decimal number in current selected units.

### **Description**

This query gets the lower full-scale of the module [x].

### **Example 1:**

TX> :SOUR:PRES:RANG:LOW?

RX> :SOUR:PRES:RANG:LOW "-1000mbar g"

### **Example 2:**

TX> :SOUR1:PRES:RANG:LOW?

RX> :SOUR:PRES:RANG:LOW "-1000mbar g"



## :SOUR:PRES:SLEW

Applicability: PACE5000, PACE6000

### Command Syntax

**:SOURce[x][:PRESsure]:SLEW <decimal>**

where x = 1 or 2 is the module number (default - 1)

Parameter: <decimal> rate in current pressure units/current time units (/s or /m) or enumerated string maximum or minimum rate.

Short form: :SOUR:SLEW <decimal> or maximum or minimum rate

Function: Selects the pressure rate used when value rate is selected.

Default: 100

### Query Syntax

**:SOURce[x][:PRESsure]:SLEW?**

where x = 1 or 2 is the module number (default - 1)

Short form: :SOUR:SLEW?

Function: Query rate value

Response: Decimal number representing a linear slew rate value in selected units/current time units (/s or /m).

### Description

When the controller rate is selected as value, this command is used to set the controllers rate in selected units/second.

To set the slew rate used during the vent process, refer to commands:

:SOUR:PRES:LEV:IMM:AMPL:VENT:RATE

:SOUR:PRES:LEV:IMM:AMPL:VENT:UNIT

### Example:

TX> :SOUR:PRES:SLEW?

RX> :SOUR:PRES:SLEW 2.0000000

Change current unit of mbar to bar and query again:

TX> :SOUR:PRES:SLEW?

RX> :SOUR:PRES:SLEW 0.0020000

To set slew rate to other values, such as:

TX> :SOUR:PRES:SLEW 4

TX> :SOUR:PRES:SLEW?

RX> :SOUR:PRES:SLEW 4.0000000

TX> :SOUR:PRES:SLEW max

TX> :SOUR:PRES:SLEW?

RX> :SOUR:PRES:SLEW 99999999.0000000

TX> :SOUR:PRES:SLEW min

## Chapter 4. Command and Query Summary

---

TX> :SOUR:PRES:SLEW?

RX> :SOUR:PRES:SLEW 0.0

## **:SOUR:PRES:SLEW:MODE**

Applicability: PACE5000, PACE6000

### **Command Syntax**

**:SOURce[x][:PRESsure]:SLEW:MODE <enumerated>**

where x = 1 or 2 is the module number (default - 1)

Parameter: <enumerated>  
MAXimum - maximum rate  
LINear - user selected linear rate

Short form: :SOUR:SLEW:MODE <enumerated>

Function: Select the rate the controller should use to achieve set-point.

Default: MAXimum

### **Query Syntax**

**:SOURce[x][:PRESsure]:SLEW:MODE?**

where x = 1 or 2 is the module number (default - 1)

Short form: :SOUR:SLEW:MODE?

Function: Query rate mode.

Response: MAX for maximum rate  
LIN for user defined rate

### **Description**

The controller can operate in two rate modes - maximum and linear. In maximum rate the controller tries to achieve set-point as quickly as possible. In linear mode the controller achieves the set-point at a user selected rate.

### **Example 1:**

```
TX> :SOUR:PRES:SLEW:MODE max
TX> :SOUR:PRES:SLEW:MODE?
RX> :SOUR:PRES:SLEW:MODE MAX
```

### **Example 2:**

Can be set to user defined rate:

```
TX> :SOUR:PRES:SLEW:MODE lin
TX> :SOUR:PRES:SLEW:MODE?
RX> :SOUR:PRES:SLEW:MODE LIN
```

# **:SOUR:PRES:SLEW:OVER:STAT**

Applicability: PACE5000, PACE6000

### Command Syntax

**:SOURce[x][:PRESsure]:SLEW:OVERshoot[:STATe] <Boolean>**

where x = 1 or 2 is the module number (default - 1)

Parameter: <boolean>  
0 - overshoot not allowed  
1 - overshoot allowed

Short form: :SOUR:PRES:SLEW:OVER <Boolean>

Function: Selects pressure overshoot to `allowed` or `not allowed`.

Default: 1 - overshoot allowed

### Query Syntax

**:SOURce[x][:PRESsure]:SLEW:OVERshoot[:STATe]?**

where x = 1 or 2 is the module number (default - 1)

Short form: :SOUR:PRES:SLEW:OVER?

Function: Query overshoot state

Response: 0 - overshoot not allowed  
1 - overshoot allowed

### Description

The controller can reach the set-point in one of two modes:

Overshoot `not allowed`, the controller changes the pressure to near the set-point. The rate of pressure change slows when approaching the set-point to avoid overshoot.

Overshoot `allowed`, the controller achieves set-point as fast as possible and, when approaching the set-point, may overshoot or undershoot.

### Example 1:

```
TX> :SOUR:PRES:SLEW:OVER?
```

```
RX> :SOUR:PRES:SLEW:OVER:STAT 0
```

### Example 2:

```
TX> :SOUR:PRES:SLEW:OVER 1
```

```
TX> :SOUR:PRES:SLEW:OVER?
```

```
RX> :SOUR:PRES:SLEW:OVER:STAT 1
```

---

## :SOUR:SPE:LEV:IMM:AMPL

Applicability: PACE6000

### Command Syntax

**:SOURce[x]:SPEed[:LEVel][:IMMediate][:AMPLitude] <decimal>**

where x = 1 or 2 is the module number (default - 1)

Parameter: <decimal> Airspeed in current units

Short form: :SOUR:SPE <decimal>

Function: Sets the airspeed set-point

Default: 0.0

### Query Syntax

**:SOURce[x]:SPEed[:LEVel][:IMMediate][:AMPLitude]?**

where x = 1 or 2 is the module number (default - 1)

Short form: :SOUR:SPE?

Function: Programmable set-point value

Response: Decimal number representing airspeed set-point in current units.

### Description

This command sets the airspeed set-point. This query gets the decimal number representing airspeed set-point in current units.

**Note:** If the instrument is not in aeronautical mode it returns an error: -221. Settings conflict.

# :SOUR:SPE:SLEW

Applicability: PACE6000

### Command Syntax

**:SOURce[x]:SPEed[:LEVel][:IMMediate][:AMPLitude]:SLEW<decimal>**

where x = 1 or 2 is the module number (default - 1)

Parameter: <decimal> Airspeed rate set-point in current units per second.

Short form:

Function: Sets the rate set-point for airspeed.

Default: 0.0

### Query Syntax

**:SOURce[x]:SPEed[:LEVel][:IMMediate][:AMPLitude]:SLEW?**

where x = 1 or 2 is the module number (default - 1)

Short form:

Function: Queries the rate set-point for airspeed.

Response: Decimal number representing the rate set-point airspeed in currently selected units of speed per second.

### Description

This command sets the airspeed rate set-point. The query gets the rate set-point for airspeed.

**Note:** If the instrument is not in aeronautical mode it returns an error: -221. Settings conflict.

---

## STATUS

The STATUS subsystem supports the OPERATION status register as defined in SCPI protocol.

### **:STAT:OPER:COND**

Applicability: PACE1000, PACE5000, PACE6000

#### **Command Syntax**

**n/a**

Parameter:

Short form:

Function:

#### **Query Syntax**

**:STATus:OPERation:CONDition?**

Short form: :STAT:OPER:COND?

Function: Query condition register

Response: Contents of condition register

#### **Description**

Returns the contents of the 16 bit condition register, see section on status reporting.

### **:STAT:OPER:ENAB**

Applicability: PACE1000, PACE5000, PACE6000

#### **Command Syntax**

##### **:STATus:OPERation:ENABle <integer>**

Parameter: <integer> 16 bit value to set enable bits  
Short form: STAT:OPER:ENAB <integer>  
Function: Controls the status operation enable register.  
Default: 0  
(Minimum: 0)  
(Maximum: 32767)

#### **Query Syntax**

##### **:STATus:OPERation:ENABle?**

Short form: :STAT:OPER:ENAB?  
Function: Query enable register  
Response: 16 bit value of enable register.

#### **Description**

Controls the bits that pass through the status reporting system, see status reporting section.



---

## **:STAT:OPER:EVEN**

Applicability: PACE1000, PACE5000, PACE6000

### **Command Syntax**

**n/a**

Parameter:

Short form:

Function:

Default:

### **Query Syntax**

**:STATus:OPERation:[EVENT]?**

Short form: :STAT:OPER:EVEN?

Function: Query event register

Response: 16 bit value of event register.

### **Description**

Reads contents of event register, see status reporting section.

### **:STAT:OPER:PRES:COND**

Applicability: PACE1000, PACE5000, PACE6000

#### **Command Syntax**

**n/a**

Parameter:

Short form:

Function:

Default:

#### **Query Syntax**

**:STATus:PRESSure:OPERation:CONDition?**

Short form: :STAT:OPER:PRES:COND?

Function: Reads the contents of the pressure condition register.

Response: Contents of pressure condition register.

#### **Description**

Returns the contents of the 16 bit pressure condition register, see section on status reporting.

---

## **:STAT:OPER:PRES:ENAB**

Applicability: PACE1000, PACE5000, PACE6000

### **Command Syntax**

**:STATus:OPERation:PRESSure:ENABLE <integer>**

Parameter: <integer> 16 bit value to set pressure enable bits

Short form: STAT:OPER:PRES:ENAB <integer>

Function: Controls the pressure status operation enable register.

Default: 0  
(Minimum: 0)  
(Maximum: 32767)

### **Query Syntax**

**:STATus:OPERation:PRESSure:ENABLE?**

Short form: :STAT:OPER:PRES:ENAB?

Function: Query enable register.

Response: 16 bit value of pressure enable register.

### **Description**

Controls the bits that pass through the status reporting system, see status reporting section.

# **:STAT:OPER:PRES:EVEN**

Applicability: PACE5000, PACE6000

### **Command Syntax**

**n/a**

Parameter:

Short form:

Function:

### **Query Syntax**

**:STATus:OPERation:PRESSure[:EVENT]?**

Short form: :STAT:OPER:PRES?

Function: Reads contents of pressure event register

Response: 16 bit value of pressure event register.

### **Description**

Reads contents of pressure event register, see status reporting section.

### **Example \*SRE and \*STB**

TX> \*SRE 255 To enable every bit of SRE register;

TX> FRED Deliberately type a wrong command, such as;

TX> \*STB? Now queries Status Byte;

TX> \*STB 68 Error Message set EAV and SERIAL POLL set MSS, 22+26 = 68;

TX> \*STB 0 Previous read STB clears it.

Refer to Figure 3-1.

**Example of Pressure Event Generated SRQ**

TX> *SRE 128	Enable SRE bit 7
TX> :STAT:OPER:ENAB 1024	Enable Operation Register, bit 10
TX> :STAT:OPER:PRES:ENAB 32767	Enable Pressure register all 16 bit
TX> :STAT:OPER:PRES:EVEN?	Query Pressure Event
RX> :STAT:OPER:PRES:EVEN 0	No any even yet
TX> :SENS:PRES?	What's the controller pressure now?
RX> :SENS:PRES 1099.9993896	It is 1100 mbar
TX> :OUTP 1	Switch controller on
TX> :SOUR:PRES 2000	To generate an in-limit event
RX> :SRQ 192	Receive an SRQ automatically
TX> :STAT:OPER:PRES:EVEN?	What happened to Pressure event?
RX> :STAT:OPER:PRES:EVEN 4	In-limit event happened, see Table 3-2
TX> :STAT:OPER:PRES:EVEN?	Ask again will clear the event register
RX> :STAT:OPER:PRES:EVEN 0	It is cleared indeed

**Example of \*IDN?**

TX> \*IDN?  
 RX> \*IDN GE Druck,PACE5000 User Interface,58784,01.05.04

### **:STAT:PRES**

Applicability: PACE1000, PACE5000, PACE6000

#### **Command Syntax**

##### **:STATus:PRESet**

Parameter: <integer>

Short form: :STAT:PRES

Function: Enables the preset values to be used.

#### **Query Syntax**

n/a

Short form:

Function:

Response:

#### **Description**

Enables the 25 preset values of set-point to be used.

---

## **:STAT:QUES:COND**

Applicability: PACE1000, PACE5000, PACE6000

### **Command Syntax**

**n/a**

Parameter:

Short form:

Function:

### **Query Syntax**

**:STATus:QUESTionable:CONDition?**

Short form: :STAT:QUES:COND?

Function: Query questionable data condition register

Response: Contents of questionable data condition register

### **Description**

Returns the contents of the 16 bit questionable data condition register, see section on status reporting.

### **:STAT:QUES:ENAB**

Applicability: PACE1000, PACE5000, PACE6000

#### **Command Syntax**

**:STATus:QUESTionable:ENABle <integer>**

Parameter: <integer> 16 bit value to set enable bits

Short form: STAT:OPER:ENAB <integer>

Function: Controls the questionable data condition enable register.

Default: 0  
(Minimum: 0)  
(Maximum: 32767)

#### **Query Syntax**

**:STATus:QUESTionable:ENABle?**

Short form: :STAT:OPER:ENAB?

Function: Query questionable data condition enable register.

Response: 16 bit value of enable register.

#### **Description**

Controls the bits that pass through the questionable data condition reporting system, see status reporting section.



---

## **:STAT:QUES:EVENT**

Applicability: PACE1000, PACE5000, PACE6000

### **Command Syntax**

**n/a**

Parameter:

Short form:

Function:

### **Query Syntax**

**:STATus:QUESTionable:[EVENT]?**

Short form: :STAT:QUES?

Function: Query questionable data condition register

Response: 16 bit value of questionable data condition register.

### **Description**

Reads contents of questionable data condition register, see status reporting section.

# SYSTEM

The SYSTem subsystem consists of general purpose commands.

## **:SYST:COMM:USB**

Applicability: PACE1000, PACE5000, PACE6000

### Command Syntax

#### **:SYSTem:COMMunicate:USB**

Parameter: <boolean>  
0 - mass storage  
1 - communication

Short form: :SYST:COMM:USB

Function: Switches the communication mode between mass storage to communications.

### Query Syntax

#### **:SYSTem:COMMunicate:USB?**

Short form: :SYST:COMM:USB?  
Function: Gets the communication mode  
Response: 0 - mass storage  
1 - communication

### Description

## :SYST:ERR

Applicability: PACE1000, PACE5000, PACE6000

### Command Syntax

n/a

Parameter:

Short form:

Function:

### Query Syntax

#### :SYStem:ERRor?

Short form: :SYST:ERR?

Function: Gets next error from the error queue.

Response:

### Description

This command queries the system error queue which holds up to five errors. The instrument returns the error code "0" and message "No error" when no more errors are in the queue.

### Example:

Tx	Rx	Remarks
:SYST:ERR?	:SYST:ERR 0, No error	
:CAL1:PRES:POIN?	None	
:SYST:ERR?	:SYST:ERR -203,"Access error; Incorrect password"	Calibration mode not enabled
:SYST:ERR?	:SYST:ERR 0, No error	Not errors, error queue empty

To test the system, send a wrong command, such as:

```
TX> :SENS:PRES qwer
```

Ask for error:

```
TX> :SYST:ERR?
```

```
RX> :SYST:ERR -200,"Execution error;Query or command violation"
```

This query empties the error stack, another query returns "No error".

```
TX> :SYST:ERR?
```

# **:SYST:DATE**

Applicability: PACE1000, PACE5000, PACE6000

### **Command Syntax**

#### **:SYSTem:DATE**

Parameter: Integer in date format.

Short form: :SYST:DATE

Function: Sets the date.

### **Query Syntax**

#### **:SYSTem:DATE?**

Short form: :SYST:DATE?

Function: Queries date

Response: Returns date setting.

### **Description**

Replies with the date settings in year, month, and day order.

### **Example:**

The system date can be set by:

```
TX> :SYST:DATE 9, 5, 2
```

```
TX> :SYST:DATE?
```

```
RX> :SYST:DATE 9, 5, 2
```

```
TX> :SYST:DATE?
```

```
RX>:SYST:DATE 9, 4, 1
```

It returns current date in year, month, and day order.

## :SYST:SET

Applicability: PACE5000, PACE6000

### Command Syntax

#### :SYSTem:SET[x]

where x = 1 or 2 is the module number (default - 1)

Parameter: Enumerated (measure or control) and a decimal number of set-point.

Short form: :SYST:SET

Function: This command only effective at switch-on condition and can set the controller on with a set-point.

### Query Syntax

#### :SYSTem:SET[x]?

where x = 1 or 2 is the module number (default - 1)

Short form: :SYST:SET?

Function: Queries current system setting.

Response: Returns current settings in either measure or control with current set-point value.

### Description

#### Example:

```
TX> :SYST:SET?
```

```
RX> :SYST:SET MEAS, 0.0
```

At the current system set, when the instrument is switched on, the controller will be in measurement mode and the set-point will be zero.

This command can set the instrument to control mode, immediately after switch-on, with a set-point to 100 mbar, by sending:

```
TX> :SYST:SET CONT, 100.0
```

```
TX> :SYST:SET?
```

```
RX> :SYST:SET CONT, 100.0000000
```

**Note:** The controller will not change mode without a switch on/off process. During normal operations use the following command example:

```
TX> :SOUR 2000
```

```
TX> :OUTP 1
```

This switches on the controller immediately with a set-point of 2000 mbar.

# **:SYST:TIME**

Applicability: PACE1000, PACE5000, PACE6000

### **Command Syntax**

#### **:SYSTem:TIME**

Parameter: Integer in time format.

Short form: :SYST:TIME

Function: Sets the time.

### **Query Syntax**

#### **:SYSTem:TIME?**

Short form: :SYST:TIME?

Function: Returns current time in hour, minute and second.

Response: Sends in order: hour, minute and second.

### **Description**

This command sets the time. The command query returns the current time in hour, minute and second order.

### **Example:**

TX> :SYST:TIME?

RX> :SYST:TIME 10, 8, 44

It returns current time in hour, minute and second order.

Time can be reset by:

TX> :SYST:TIME 11, 11, 2

TX> :SYST:TIME?

RX> :SYST:TIME 11, 11, 4

## **:SYST:COMM:SER:CONT:RTS**

Applicability: PACE1000, PACE5000, PACE6000

### **Command Syntax**

#### **:SYSTem:COMMunicate:SERial:CONTrol:RTS**

Parameter: Boolean, ON or OFF

Short form: :SYST:COMM:SER:RTS[x]

Function: Sets the serial communication hardware handshaking where:

[x] =

0: OFF

1: ON

### **Query Syntax**

#### **:SYSTem:COMMunicate:SERial:CONTrol:RTS?**

Short form: :SYST:COMM:SER:CONT:RTS?

Function: Queries serial communication handshaking.

Response: Returns 0 or 1.

### **Description**

Selects serial communications hardware handshaking. The command query requests the current serial communication hardware handshaking.

#### **Example: 1**

TX> :SYST:COMM:SER:CONT:RTS?

RX> :SYST:COMM:SER:CONT:RTS 0 Hardware handshaking OFF.

#### **Example: 2**

TX> :SYST:COMM:SER:CONT:RTS1 Hardware handshaking ON.

TX> :SYST:COMM:SER:CONT:RTS? Query again

RX> :SYST:COMM:SER:CONT:RTS 1 Confirmed

# **:SYST:COMM:SER:CONT:XONX**

Applicability: PACE1000, PACE5000, PACE6000

### **Command Syntax**

**:SYSTem:COMMunicate:SERial:CONTrol:XONXoff**

Parameter: Integer

Short form: :SYST:COMM:SER:XONX

Function: Sets the serial communication handshaking of:

0: NONE

1: XON/XOFF

2: RTS/CTS

### **Query Syntax**

**:SYSTem:COMMunicate:SERial:CONTrol:XONXoff?**

Short form: :SYST:COMM:SER:CONT:XONX?

Function: Queries serial communication handshaking.

Response: Returns an integer of 0, 1, 2.

### **Description**

Selects serial communications interface handshaking. The command query requests the current serial communication handshaking.

### **Example:**

TX> :SYST:COMM:SER:CONT:XONX?

RX> :SYST:COMM:SER:CONT 0

The current hardware handshaking is NONE

It can be set to RTS/CTS by sending:

TX> :SYST:COMM:SER:CONT 2



## :SYST:COMM:SER:BAUD

Applicability: PACE1000, PACE5000, PACE6000

### Command Syntax

#### :SYSTem:COMMunicate:SERial:BAUD

Parameter: Integer

Short form: :SYST:COMM:SER:BAUD

Function: Sets the baud rate

**Note:** The parameter must be a valid baud rate number.

### Query Syntax

#### :SYSTem:COMMunicate:SERial:BAUD?

Short form: :SYST:COMM:SER:BAUD?

Function: Queries current baud setting.

Response: Current baud setting.

### Description

This command instructs the instrument to set the baud rate. The command query returns the current baud rate set in the instrument.

### Example:

```
TX> :SYST:COMM:SER:BAUD?
```

```
RX> :SYST:COMM:SER:BAUD 9600
```

The current baud-rate is 9600 bit/second.

It can be set to another baud rate (example: 19200) by sending:

```
TX> :SYST:COMM:SER:BAUD 19200
```

**Note:** The parameter must be a valid baud rate number:

- 2400
- 4800
- 9600
- 19200
- 38400
- 57600
- 115200

**Note:** Changing to a new baud rate causes a loss of communications until resetting the local PC RS 232 to the new baud rate.

### **:SYST:COMM:SER:TYPE:PAR**

Applicability: PACE1000, PACE5000, PACE6000

#### **Command Syntax**

#### **:SYSTem:COMMunicate:SERial[:TYPE]:PARity**

Parameter: Enumerate

Short form: SYST:COMM:SER:TYPE:PAR

Function: Sets parity, odd, even or none.

This command breaks the communication between the PC and the PACE instrument. No further query can be made until after resetting the pc to the same setting. The instrument cannot be brought back to local mode.

#### **Query Syntax**

#### **:SYSTem:COMMunicate:SERial:TYPE:PARity?**

Short form: :SYST:COMM:SER:TYPE:PAR?

Function: Queries current parity setting.

Response: Returns odd, even or none.

#### **Description**

This command instructs the instrument to set serial communication parity. The command query gets the current parity setting.

#### **Example:**

TX> :SYST:COMM:SER:TYPE:PAR?

RX> :SYST:COMM:SER:TYPE:PAR NONE

The current setting ignores the parity check.

It can be set to ODD and EVEN by sending:

TX> :SYST:COMM:SER:TYPE:PAR ODD

or

TX> :SYST:COMM:SER:TYPE:PAR EVEN

---

## **:SYST:COMM:GPIB:SELF:ADDR**

Applicability: PACE1000, PACE5000, PACE6000

### **Command Syntax**

#### **:SYSTem:COMMunicate:GPIB[:SELF]:ADDRess**

Parameter: Integer

Short form: :SYST:COMM:GPIB:SELF:ADDR

Function: Sets the instrument's GPIB address.

### **Query Syntax**

#### **:SYSTem:COMMunicate:GPIB:SELF:ADDRess?**

Short form: :SYST:COMM:GPIB:SELF:ADDR?

Function: Queries GPIB address

Response: Returns decimal number representing GPIB address.

### **Description**

This command instructs the instrument to set a GPIB address. The query command gets the current address.

### **Example:**

TX> :SYST:COMM:GPIB:SELF:ADDR?

RX> :SYST:COMM:GPIB:SELF:ADDR 1                      Current GPIB address is 1

TX> :SYST:COMM:GPIB:SELF:ADDR 16                    Set address to 16

TX> :SYST:COMM:GPIB:SELF:ADDR?

RX> :SYST:COMM:GPIB:SELF:ADDR 16

# :SYST:AREA

Applicability: PACE1000, PACE5000, PACE6000

### Command Syntax

**:SYSTem:AREA<space><parameter>**

Parameter: String, see below

Form: :SYST:AREA<space><string>

Function: Sets a group of parameters for an area of the world.

### Query Syntax

**:SYSTem:AREA?**

Form: :SYST:AREA?

Function: Queries area setting.

Response: :SYST:AREA<space><string>

### Description

This command instructs the instrument to enable a group of default settings for an area of the world.

AREA	Remarks
ASIA	Asia
EUR	Europe
EUROPE	Europe
JAP	Japan
JAPAN	Japan
ROW	Rest of the World
USA	United States of America

### Example:

Tx	Rx	Remarks
:SYST:AREA?	:SYST:AREA EUR	Area of use is set to Europe.
:SYST:AREA USA	None	Sets the area of use to the USA.
:SYST:AREA?	:SYST:AREA USA	Area of use is set to the USA.
:SYST:AREA JAPAN	None	Sets the area of use to Japan.
:SYST:AREA?	:SYST:AREA JAP	Area of use is set to Japan.
:SYST:AREA ASIA	None	Sets the area of use to Asia.
:SYST:AREA?	:SYST:AREA ASIA	Area of use is set to ASIA.
:SYST:AREA ROW	None	Sets the area of use to the rest of the World.
:SYST:AREA?	:SYST:AREA ROW	Area of use is set to the rest of the World.

---

## **:SYST:PASS:CDIS**

Applicability: PACE1000, PACE5000, PACE6000

### **Command Syntax**

#### **:SYSTem:PASSword:CDISable**

Parameter: 2317100

Short form: SYST:PASS:CDIS<space>[parameter]

Function: Disables the calibration with a password.

### **Query Syntax**

**n/a**

Short form:

Function:

Response:

### **Description**

This command disables calibration mode with the parameter above used as a password. To enable calibration mode refer to commands “:SYST:PASS:CED” and “:SYST:PASS:CEN:STAT.”.

### **Example:**

```
TX> :SYST:PASS:CEN:STAT?
```

```
RX> :SYST:PASS:CEN:STAT 1
```

```
TX> :SYST:PASS:CDIS 2317100
```

```
RX> None
```

```
TX> :SYST:PASS:CEN:STAT?
```

```
RX> :SYST:PASS:CEN:STAT 0
```

# **:SYST:PASS:CEN**

Applicability: PACE1000, PACE5000, PACE6000

### **Command Syntax**

#### **:SYSTem:PASSword:CENable:**

Parameter: 2317100

Short form: :SYST:PASS:CEN<space>[parameter]

Function: Enables calibration, default condition - disabled (calibration is not allowed).

### **Query Syntax**

**n/a**

Short form:

Function:

Response:

### **Description**

This command enables calibration mode with the above parameter used as a password. To disable calibration mode refer to commands “:SYST:PASS:CDIS” and “:SYST:PASS:CEN:STAT?”.

### **Example:**

TX> :SYST:PASS:CEN:STAT?

RX> :SYST:PASS:CEN:STAT 0

TX> :SYST:PASS:CEN 2317100

RX> None

TX> :SYST:PASS:CEN:STAT?

RX> :SYST:PASS:CEN:STAT 1

TX> :SYST:PASS:CDIS 2317100

RX> None

TX> :SYST:PASS:CEN:STAT?

RX> :SYST:PASS:CEN:STAT 0

## **:SYST:PASS:CEN:STAT**

Applicability: PACE1000, PACE5000, PACE6000

### **Command Syntax**

**n/a**

Parameter:

Short form:

Function:

### **Query Syntax**

**:SYSTem:PASSword:CENable:STATe?**

Short form: :SYST:PASS:CEN:STAT?

Function: Gets the status of the calibration password.

Response: 0 - disabled

1 - enabled

### **Description**

This query asks if the calibration is enabled or disabled.

### **Example:**

It can be enabled by sending command and password

```
TX> :SYST:PASS:CEN 2317100
```

```
TX> :SYST:PASS:CEN:STAT?
```

```
RX> :SYST:PASS:CEN:STAT 1
```

When enabled and a 3-point calibration can be carried out.

It can be disabled again by issuing a command and a password, such as:

```
TX> :SYST:PASS:CDIS 2317100
```

```
TX> :SYST:PASS:CEN:STAT?
```

```
RX> :SYST:PASS:CEN:STAT 0
```

# **:SYST:VERS**

Applicability: PACE1000, PACE5000, PACE6000

### **Command Syntax**

**n/a**

Parameter:

Short form:

Function:

### **Query Syntax**

#### **:SYStem:VERSion?**

Short form: :SYST:VERS?

Function: Returns the SCPI version.

Response: version number

### **Description**

Replies with the SCPI version number.

### **Example:**

TX> :SYST:VERS?

RX> :SYST:VERS 1995.0



---

## UNIT

The UNIT sub-system configures the instrument's pressure measurement units.

### **:UNIT:ALT**

Applicability: PACE1000, PACE6000

#### **Command Syntax**

##### **:UNIT:ALTitude**

Parameter: <name>

Short form: :UNIT:ALT

Function: Selects altitude units.

#### **Query Syntax**

##### **:UNIT:ALTitude?**

Short form: :UNIT:ALT?

Function: Queries what altitude units are selected

Response: SUFFIX DATA

#### **Description**

This command selects the altitude units. The query gets the altitude units are selected.

**Note:** If the instrument is not in aeronautical mode it returns an error: -221, "Settings conflict".

### **:UNIT:CONV**

Applicability: PACE1000, PACE5000, PACE6000

#### **Command Syntax**

##### **:UNIT:CONVert**

Parameter: <name>  
Short form: :UNIT:CONV  
Function: Converts units.

#### **Query Syntax**

**n/a**

Short form:  
Function:  
Response:

#### **Description**

This command converts units.

## :UNIT:PRES

Applicability: PACE1000, PACE5000, PACE6000

### Command Syntax

**:UNIT[x]:PRESsure] <name>**

where x = 1 or 2 is the module number (default - 1)

Parameter: <name>

Valid units: Refer to :INStrument:UNIT for valid unit list.

**Note:** Take care when entering the units, the letter 'O' can easily be mistaken for the number '0' or vice versa.

Short form: :UNIT <name>

Function: Selects pressure units

### Query Syntax

**:UNIT[x]:PRESsure]?**

where x = 1 or 2 is the module number (default - 1)

Short form: :UNIT?

Function: Query what pressure units are selected

Response: name as above

### Description

This command selects the current pressure units; USER1 to USER4 are the user defined units.

### Example:

```
TX> :UNIT:PRES?
```

```
RX> :UNIT:PRES MBAR
```

The current unit is mbar

It can be set to another unit, such as bar by sending:

```
TX> :UNIT:PRES bar
```

```
TX> :UNIT:PRES?
```

```
RX> :UNIT:PRES BAR
```

The reply to this query confirms the change, the front panel display can also confirm the change.

### **:UNIT:PRES:DEF**

Applicability: PACE1000, PACE5000, PACE6000

#### **Command Syntax**

**:UNIT[x][:PRESsure]:DEFine[y] <string>,<decimal>**

where: x = 1 or 2 is the module number (default - 1) and y = 1, 2, 3 or 4 is the number of user defined units (default - 1).

Parameter: <string> ASCII representation of unit name.

<decimal> Conversion factor from Pascals to required units

Short form: :UNIT[x]DEF[y] <string>,<decimal>

Function: There are four user defined units on the instrument. This command defines the name and conversion factor to use.

Default:

string	N/A
number	1000.0
(Minimum string)	""
(Minimum number)	0.0
(Maximum string)	8 characters
(Maximum number)	1000.0

#### **Query Syntax**

**:UNIT[x][:PRESsure]:DEFine[y]?**

where x = 1 or 2 is the module number (default - 1) and y = 1, 2, 3 or 4 is the number of user defined units (default - 1).

Short form: :UNIT[x]DEF[y]?

Function: Query conversion factor

Response: A string representing name and number corresponding to the conversion factor.

#### **Description**

This command defines the name and conversion factor for the special units. This conversion factor is from Pascals to the required units. An index of 1 is for USER1 unit and an index of 2 is for USER2 unit.

<b>y</b>	<b>Special Units</b>
1	USER1
2	USER2
3	USER3
4	USER4

**Example 1:**

By default:

```
TX> :UNIT:PRES:DEF?
RX> :UNIT:PRES:DEF "UserUnit1", 1000.0000000
TX> :UNIT:PRES:DEF1?
RX> :UNIT:PRES:DEF "UserUnit1", 1000.0000000
TX> :UNIT:PRES:DEF2?
RX> :UNIT:PRES:DEF2 "UserUnit2", 1000.0000000
TX> :UNIT:PRES:DEF3?
RX> :UNIT:PRES:DEF3 "UserUnit3", 1000.0000000
TX> :UNIT:PRES:DEF4?
RX> :UNIT:PRES:DEF4 "UserUnit4", 1000.0000000
```

The first parameter is the unit name and the second the equivalent pressure in Pascals.

**Example 2: Defining 'MyUnit'**

Setting USER4 as 'MyUnit':

```
TX> :UNIT:PRES:DEF4 "MyUnit", 2000.0
TX> :UNIT:PRES:DEF4?
RX> :UNIT:PRES:DEF4 "MyUnit", 2000.0000000
```

Select 'MyUnit' for use:

```
TX> :UNIT:PRES USER4
TX> :UNIT:PRES?
RX> :UNIT:PRES USER4
```

The front panel display shows "MyUnit" and uses it for measurement, set-point, full-scales and source pressures.

**Example 3:**

The following query:

```
TX> :SENS:PRES?
RX> :SENS:PRES 5.0000187
```

Returns a number in 'MyUnit'

To confirm:

```
TX> :UNIT:PRES?
RX> :UNIT:PRES USER4
```

To find conversion factor for 'MyUnit'

```
TX> :UNIT:PRES:DEF4?
RX> :UNIT:PRES:DEF4 "MyUnit", 2000.0000000
```

Calculate equivalent in Pascals: 5.0000187 multiplied by 2000.0000000.

### **:UNIT:SPE**

Applicability: PACE1000, PACE6000

#### **Command Syntax**

##### **:UNIT:SPEed**

Parameter: <name>

Short form: :UNIT:SPE

Function: Selects airspeed units.

#### **Query Syntax**

##### **:UNIT:SPEed?**

Short form: :UNIT:SPE?

Function: Queries the selected airspeed units.

Response: SUFFIX DATA

#### **Description**

This command selects the airspeed units. The query gets the selected airspeed units.

### **4.5 Common Commands**

The commands identified with \* are SCPI common commands.

## **\*CLS**

### **Command Syntax**

#### **\*CLS**

Parameter: None  
Short form: \*CLS  
Function: This command clears the all queues.

### **Query Syntax**

#### **n/a**

Parameter:  
Function:  
Response:

### **Description**

Clears all event and condition register, see status reporting section.

### **\*ESE**

#### **Command Syntax**

##### **\*ESE <integer>**

Parameter: integer 8 bit value of enable mask  
Short form: \*ESE <integer>  
Function: Sets the Standard Event Status enable register.  
Default: 0  
(Minimum: 0)  
(Maximum: 255)

#### **Query Syntax**

##### **\*ESE?**

Short form: \*ESE?  
Function: Query Standard Event Status Enable register.  
Response: 8 bit integer of contents of Standard Event Status Enable register.

#### **Description**

See Standard Event Group, Section 3.3 and Figure 3-1.



## **\*ESR**

### **Command Syntax**

**n/a**

Parameter:

Short form:

Function:

### **Query Syntax**

**\*ESR?**

Short form:           \*ESR?

Function:            Queries the Standard Event Status Register

Response:            8 bit integer of contents of Standard Event Status register.

### **Description**

See Standard Event Group, Section 3.3 and Figure 3-1.

### **\*IDN?**

#### **Command Syntax**

**n/a**

Parameter:

Short form:

Function:

#### **Query Syntax**

**\*IDN?**

Short form:            \*IDN?

Function:             Queries the identification of the instrument.

Response:            A comma separated list containing manufacture, model, serial number and software version.

#### **Description**

Return identification

#### **Example:**

RX> \*IDN Druck,PACEnnnn,1234,01.00.00

where: n = PACE model number

## \*OPC

### Command Syntax

#### \*OPC

Parameter: None

Short form: \*OPC

Function: When all operations have been completed, event 800 is written to the error/event queue (if enabled by STAT:QUE:ENAB). At the same time, this command allows the OPC bit in the standard event register to be set. This can be used to trigger a serial poll, see \*ESR for details. If there are no pending operations these actions are performed immediately. This command should be sent each time the OPC bit is allowed to be set.

Default: -

**Note:** It is intended that the \*OPC command should be the last command in a program message.

### Query Syntax

#### \*OPC?

Short form: \*OPC?

Function: When all operations have been completed a '1' is written to the output queue this can be used to trigger a serial poll, see \*SRE for details.

Response: If there are no pending operations a '1' is written to the queue immediately.

**Note:** It is intended that the \*OPC command should be the last command in a program message.

### Description

This command sets the OPC bit in the standard event register. The query returns '1' when all operations have been completed.

### **\*SRE**

#### **Command Syntax**

##### **\*SRE <integer>**

Parameter: integer 8 bit value of enable mask  
Short form: \*SRE <integer>  
Function: Sets the Service Request Enable register.  
Default: -  
(Minimum: 0)  
(Maximum: 255)

#### **Query Syntax**

##### **\*SRE?**

Short form: \*SRE?  
Function: Query Service Request Enable register.  
Response: 8 bit integer of contents of Service Request Enable register.

#### **Description**

See Status Byte Group, Section 3.5 and Figure 3-1.

## **\*STB?**

### **Command Syntax**

**n/a**

Parameter:

Short form:

Function:

### **Query Syntax**

**\*STB?**

Short form:           \*STB?

Function:             Queries the Status Register

Response:            8 bit integer of contents of Status register.

### **Description**

See status reporting section.

### **\*TST?**

#### **Command Syntax**

**n/a**

Parameter:

Short form:

Function:

#### **Query Syntax**

**\*TST?**

Short form:            \*TST?

Function:             Queries the self-test status.

Response:            Returns '0' indicates fail, '1' indicates pass.

#### **Description**

On a self-test failure an error message can be stored in the error/event queue. The unit's hardware status cannot be changed during that test.

## **\*WAI**

### **Command Syntax**

#### **\*WAI**

Parameter: None  
Short form: \*WAI  
Function: No further commands are carried out until the completion of all pending operations. This command is ignored if all operations have been completed.

### **Query Syntax**

#### **n/a**

Short form:  
Function:  
Response:

### **Description**

This command stops further commands from being carried out until the completion of all pending operations.

## **4.6 Instrument Control Commands**

The following commands identified with : are SCPI instrument control commands.

### **:GTL**

Applicability: PACE1000, PACE5000, PACE6000

#### **Command Syntax**

##### **:GTL**

Parameter: none

Short form: :GTL

Function: Go to local

#### **Query Syntax**

**n/a**

Short form:

Function:

Response:

#### **Description**

Takes the instrument out of local lockout mode; the key-pad on the instrument becomes active.



## **:LLO**

Applicability: PACE1000, PACE5000, PACE6000

### **Command Syntax**

#### **:LLO**

Parameter: none

Short form: :LLO

Function: Local lock-out

### **Query Syntax**

**n/a**

Short form:

Function:

Response:

### **Description**

Locks the instrument out of local mode. The instrument will no longer be in local mode and cannot be operated from the front panel.

### **:LOC**

Applicability: PACE1000, PACE5000, PACE6000

#### **Command Syntax**

##### **:LOC**

Parameter: none  
Short form: LOC  
Function: Local mode

#### **Query Syntax**

**n/a**

Short form:

Function:

Response:

#### **Description**

Puts the instrument into local mode. The instrument will no longer be in remote mode and can be operated from the front panel.

## **:REM**

Applicability: PACE1000, PACE5000, PACE6000

### **Command Syntax**

#### **:REM**

Parameter: none

Short form: :REM

Function: Selects remote mode

### **Query Syntax**

**n/a**

Short form:

Function:

Response:

### **Description**

Sets the instrument in remote mode. The instrument will no longer be in local mode and cannot be operated from the front panel.

### **:SRQ**

Applicability: PACE1000, PACE5000, PACE6000

#### **Command Syntax**

##### **:SRQ**

Parameter: none

Short form: :SRQ

Function: Sends a service request to read messages.

#### **Query Syntax**

n/a

Short form:

Function:

Response:

#### **Description**

A service request causes all messages to be read from the register.

## **:SRQ:ENAB**

Applicability: PACE1000, PACE5000, PACE6000

### **Command Syntax**

#### **:SRQ:ENABLE**

Parameter: none

Short form: :SRQ:ENAB

Function: Sets a service request to read messages.

### **Query Syntax**

#### **:SRQ:ENABLE?**

Short form: :SRQ:ENAB?

Function: Gets the messages in the register.

### **Description**

A service request causes all messages to be read from the register.

### **:SYN**

Applicability: PACE1000, PACE6000

#### **Command Syntax**

**n/a**

Parameter:

Short form:

Function:

#### **Query Syntax**

**:SYN?**

Short form: :SYN?

Function: Queries synchronization.

Response: <boolean>

0 - not synchronized

1 - synchronized

#### **Description**

Query for synchronization purposes.

## 5. Errors

Negative error numbers are used for standard SCPI errors. Positive error numbers are device specific errors. Following the error number, a message describes the error. An error, when detected, is held in the error queue.

When SYST:ERR? is sent any error in the error queue sets the error bit in the event status register.

### 5.1 Error Numbers

Each error detected causes an error number with an error message to be returned as follows:

**Table 5-1: Errors -100 to -199**

Error Code	Error Message
-102	-102, "Syntax error"
-104	-104, "Data type error"
-108	-108, "Parameter not allowed"
-109	-109, "Missing parameter"
-110	-110, "Command Header Error"
-111	-111, "Header Separator Error"
-112	-112, "Program mnemonic too long"
-113	-113, "Undefined header"
-114	-114, "Header suffix out of range"
-120	-120, "Numeric data error"
-121	-121, "Invalid character in number"
-123	-123, "Exponent too large"
-124	-124, "Too many digits"
-128	-128, "Numeric data not allowed"
-130	-130, "Suffix error"
-131	-131, "Invalid suffix"
-134	-134, "Suffix too long"
-138	-138, "Suffix not allowed"
-140	-140, "Character data error"
-141	-141, "Invalid character data"
-144	-144, "Character data too long"
-148	-148, "Character data not allowed"
-150	-150, "String data error"
-151	-151, "Invalid string data"
-158	-158, "String data not allowed"

**Table 5-2: Errors -200 to -299**

<b>Error Code</b>	<b>Error Message</b>
-200	-200, "Execution error"
-201	-201, "Invalid while in local"
-202	-202, "Settings lost due to rtl"
-203	-203, "Command protected"
-220	-220, "Parameter error"
-221	-221, "Settings conflict"
-222	-222, "Data out of range"
-223	-223, "Too much data"
-224	-224, "Illegal parameter value"
-240	-240, "Hardware error"
-241	-241, "Hardware missing"

**Table 5-3: Errors -300 to -399**

<b>Error Code</b>	<b>Error Message</b>
-310	-310, "System error"
-350	-350, "Queue overflow"
-400	-400, "Query error"

**Table 5-4: Errors +201 to +212**

<b>Error Code</b>	<b>Error Message</b>
201	201, "Query only"
202	202, "No query allowed"
203	203, "Parameter(s) not expected"
207	207, "Enumerated value not in union"
208	208, "Illegal number of parameters"
210	210, "Run out of memory handle"
211	211, "Unit not matched"
212	212, "Unit not required"





## Office Locations



<https://druck.com/contact>

## Services and Support Locations



<https://druck.com/service>