

Models 8007 and 8008

Electro-Pneumatic Transducers

Instruction Manual (Rev. B)

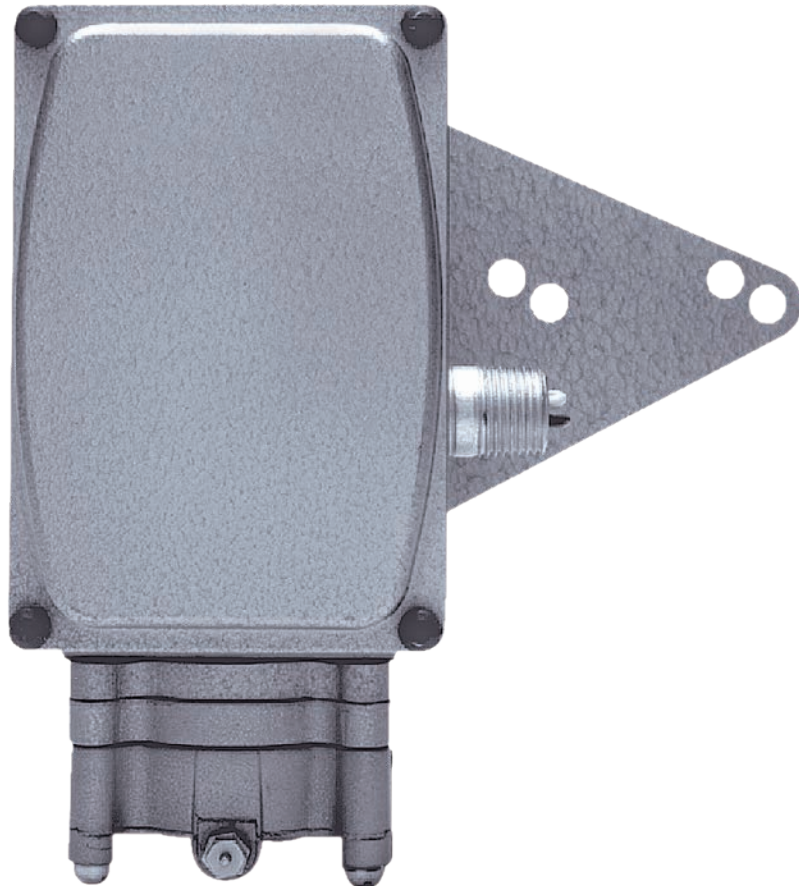

THESE INSTRUCTIONS PROVIDE THE CUSTOMER/OPERATOR WITH IMPORTANT PROJECT-SPECIFIC REFERENCE INFORMATION IN ADDITION TO THE CUSTOMER/OPERATOR'S NORMAL OPERATION AND MAINTENANCE PROCEDURES. SINCE OPERATION AND MAINTENANCE PHILOSOPHIES VARY, BAKER HUGHES AND ITS SUBSIDIARIES AND AFFILIATES) DOES NOT ATTEMPT TO DICTATE SPECIFIC PROCEDURES, BUT TO PROVIDE BASIC LIMITATIONS AND REQUIREMENTS CREATED BY THE TYPE OF EQUIPMENT PROVIDED.

THESE INSTRUCTIONS ASSUME THAT OPERATORS ALREADY HAVE A GENERAL UNDERSTANDING OF THE REQUIREMENTS FOR SAFE OPERATION OF MECHANICAL AND ELECTRICAL EQUIPMENT IN POTENTIALLY HAZARDOUS ENVIRONMENTS. THEREFORE, THESE INSTRUCTIONS SHOULD BE INTERPRETED AND APPLIED IN CONJUNCTION WITH THE SAFETY RULES AND REGULATIONS APPLICABLE AT THE SITE AND THE PARTICULAR REQUIREMENTS FOR OPERATION OF OTHER EQUIPMENT AT THE SITE.

THESE INSTRUCTIONS DO NOT PURPORT TO COVER ALL DETAILS OR VARIATIONS IN EQUIPMENT NOR TO PROVIDE FOR EVERY POSSIBLE CONTINGENCY TO BE MET IN CONNECTION WITH INSTALLATION, OPERATION OR MAINTENANCE. SHOULD FURTHER INFORMATION BE DESIRED OR SHOULD PARTICULAR PROBLEMS ARISE WHICH ARE NOT COVERED SUFFICIENTLY FOR THE CUSTOMER/OPERATOR'S PURPOSES THE MATTER SHOULD BE REFERRED TO BAKER HUGHES.

THE RIGHTS, OBLIGATIONS AND LIABILITIES OF BAKER HUGHES AND THE CUSTOMER/OPERATOR ARE STRICTLY LIMITED TO THOSE EXPRESSLY PROVIDED IN THE CONTRACT RELATING TO THE SUPPLY OF THE EQUIPMENT. NO ADDITIONAL REPRESENTATIONS OR WARRANTIES BY BAKER HUGHES REGARDING THE EQUIPMENT OR ITS USE ARE GIVEN OR IMPLIED BY THE ISSUE OF THESE INSTRUCTIONS.

THESE INSTRUCTIONS ARE FURNISHED TO THE CUSTOMER/OPERATOR SOLELY TO ASSIST IN THE INSTALLATION, TESTING, OPERATION, AND/OR MAINTENANCE OF THE EQUIPMENT DESCRIBED. THIS DOCUMENT SHALL NOT BE REPRODUCED IN WHOLE OR IN PART TO ANY THIRD PARTY WITHOUT THE WRITTEN APPROVAL OF BAKER HUGHES.

Table of Contents

About this Manual	4
Warranty	4
Copyright	4
Safety Information	5
Installation	6
Service	6
Spare Parts	6
Training.....	6
Preliminary Remarks	6
Location	6
Case Mounting	6
PROTECTION STANDARD	6
Equipment for Hazardous Atmosphere	6
Tight Equipment for Non-hazardous Atmosphere	6
Tight Equipment for Hazardous Atmosphere.....	7
ELECTRICAL CIRCUITS	7
Connecting Signal Leads	7
Connecting Coil Leads to the Terminal Board	7
Changing of Action	7
Circuit Replacement	7
Standard Circuits	9
AIR PIPING	9
Supply circuit.....	9
Output Circuit	9
ZERO ADJUSTMENT CHECK	9
Operation and Adjustments	10
Operation.....	10
Zero Adjustment	10
Beam Balance Adjustment	10
Span Adjustment	11
Maintenance	12
Metering Tube	12
Relay Disassembly.....	12
Relay Reassembly	12
Nozzle	12
Terminal Board Replacement	12
Flexure Strip Replacement.....	13
Coil Replacement	13
Beam Alignment	13
Calibration	13
Trouble-shooting	14
Air circuit.....	14
Electrical Circuit.....	14
Parts Reference	15

About this Manual

- The information in this manual is subject to change without prior notice.
- The information contained in this manual, in whole or part, shall not be transcribed or copied without written permission from Baker Hughes.
- Please report any errors or questions about the information in this manual to your local supplier.
- These instructions are written specifically for the Models 8007 and 8008 Electro-Pneumatic transducers, and do not apply for other device outside of this product line.

Warranty

Items sold by Baker Hughes are warranted to be free from defects in materials and workmanship for a period of one year from the date of shipment provided said items are used according to Baker Hughes recommended usages. Baker Hughes reserves the right to discontinue manufacture of any product or change product materials, design or specifications without notice.

Note: Prior to installation

- ***The transducer must be installed, put into service and maintained by qualified and competent professionals who have undergone suitable training.***
- ***All surrounding pipe lines must be thoroughly flushed to ensure all entrained debris has been removed from the system.***
- ***Under certain operating conditions, the use of damaged equipment could cause a degradation of the performance of the system which may lead to personal injury or death.***
- ***Changes to specifications, structure, and components used may not lead to the revision of this manual unless such changes affect the function and performance of the product.***

Copyright

All software is the intellectual property of Baker Hughes.

The complete design and manufacture are the intellectual property of Baker Hughes.

Safety Information

Important – Please Read Before Installation

These Instructions contain **DANGER**, **WARNING**, and **CAUTION** labels, where necessary, to alert you to safety related or other important information. Read the instructions carefully before installing and maintaining your instrument(s). **DANGER** and **WARNING** hazards are related to personal injury. **CAUTION** hazards involve equipment or property damage. Operation of damaged equipment can, under certain operational conditions, result in degraded process system performance that can lead to injury or death. Total compliance with all **DANGER**, **WARNING**, and **CAUTION** notices is required for safe operation.



This is the safety alert symbol. It alerts you to potential personal injury hazards. Obey all safety messages that follow this symbol to avoid possible injury or death.



Indicates a potentially hazardous situation which, if not avoided, could result in death or serious injury.



Indicates a potentially hazardous situation which, if not avoided, could result in serious injury.



Indicates a potentially hazardous situation which, if not avoided, could result in minor or moderate injury.



When used without the safety alert symbol indicates a potentially hazardous situation which, if not avoided, could result in property damage.

Note: Indicates important facts and conditions.

Installation

These instructions apply to the **Masoneilan™** Models 8007 and 8008 Electro-Pneumatic transducers.

CAUTION

This equipment should not be installed, kept up or put into operation without having read and fully understood before-hand the instructions contained in this instruction sheet. Moreover, before initiating any operation on this transducer the following should be read :

- **operating instructions pertaining particularly to installation,**
- **safety rules listed on the instruction plate attached to the cover of the device in certain cases (transducers with flameproof housing),**

Non-compliance with these rules may bring about faulty operation of the device, interfere with the installation or damage it seriously. In addition, such negligence might expose operating personnel present on the site to grave hazards.

Service

Baker Hughes has a highly skilled After Sales Department available for start-up maintenance and repair. Contact your local Baker Hughes Sales office or representative.

Spare Parts

When performing maintenance, always use Masoneilan replacement parts. Parts are obtainable through your local Baker Hughes Representative or Sales office. When ordering parts, always provide Model and Serial Numbers shown on serial plate.

Training

Baker Hughes regularly holds training programs to train customer service and instrumentation personnel in the operation, maintenance and application of our control valves and instruments. To participate in one of these training sessions, contact your local Baker Hughes Representative.

Preliminary Remarks

1. Record the serial number for future reference (6 digit number).
2. The transducer is fitted with a powerful magnet : do not bring close to it a watch or an instrument likely to deviate under the influence of a magnetic field.

Location

Temperature and vibration are factors to be considered for the location of the transducer. Avoid locations which are subject to wide ambient temperature variations. If transducer is subject to subfreezing temperatures, special provisions must be made for drying supply air. If possible, avoid locations where excessive vibration occurs.

Case Mounting

The transducer is provided with a mounting plate attached to the case by three screws for mounting to the actuators of most Masoneilan automatic control valves. Two mounting screws (5 /16" - 18 NC. 2A by 1/2" long) are required.

The transducer may be mounted in any position without changing output pressure, may also be mounted to a wall or control panel.

Never support the transducer in whole or in part, by the air piping. Provide sufficient clearance for removing cover and for access to adjustments.

PROTECTION STANDARD

The installation must be in accordance with the selected standard for the protection against explosion:

- IP65 for Flameproof Housing Transducers
- Transducers for Intrinsically Safe circuits (see Figure 2)

ELECTRICAL CIRCUITS

Connecting Signal Leads

- They are introduced in the case through the conduit connection located on the side.
- Connections to terminal board should be made respecting the polarities engraved on this terminal board.

Connecting Coil Leads to the Terminal Board

This connection determines the device action.

Direct action : (a signal increase produces an output pressure increase).

Reverse action : (a signal increase produces an output pressure decrease).

The transducer is factory adjusted for the action specified in the order. If no action has been specified, the transducer is adjusted for a direct action.

The diagram Figure 1 shows the position of the coil leads and the connecting terminals utilized on the terminal board for each action of the device.

Changing of Action

- Reverse the positions of the coil leads to the terminal board (see diagram Figure 1).
- In case of intrinsically safe circuit, replace the coil by another one corresponding to the new action (see table Figure 2).
- In case of flameproof housing device, the transducer must not be opened when the device is energized. See ATEX instruction Manual Ref. 33467.**

Notes: The safe standard concerning electrical equipment utilized in hazardous atmosphere can be identified with serial plate fastened on the side.

Besides the mark corresponding to the direction action, coils always have a code color permitting the identification of nominal resistance. In the event of coil removal, be sure that the color code of the new coil is identical with the old one. See table of Figure 3.

Be sure that leads connecting the coil to the terminal-board do not block the beam motion.

Circuit Replacement

(range of electrical signal)

If it is necessary to change the electrical signal of the transducer, ask our Spare-Parts Department for new terminal-board and a new coil; each of which is to correspond to **the new characteristics selected** (signal and input impedance), as well as to the action (direct or reverse) and to the protection standards of the device. Refer to maintenance chapter for the replacement of the terminal board and the coil.

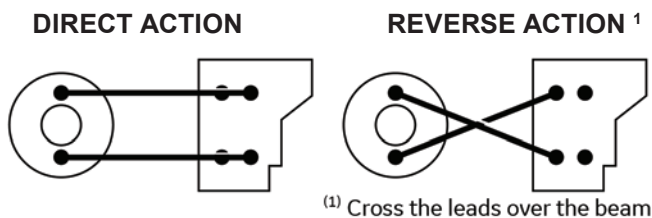

Figure 1 — Coil leads position

PROTECTION TYPES		STANDARDS	TIGHT DEGREE	USED COIL	
				DIRECT ACTION POSITIONER	REVERSE ACTION POSITIONER
EQUIPMENT FOR NON HAZARDOUS ATMOSPHERE	WATER & DUST PROOF	EUROPEAN STANDARD IP 65 according to: EN 60529	IP65 with neoprene gasket	IDENTICAL COIL  Color Code: (See Figure 3)	
	FLAMEPROOF HOUSING DEVICE	See ATEX Instruction Manual	IP65 with neoprene gasket		
EQUIPMENT FOR HAZARDOUS ATMOSPHERE	DEVICE TO BE INCORPORATED IN AN INTRINSICALLY SAFE CIRCUIT	See ATEX Instruction Manual	IP65	 Mark for direct action Color Code: Blue	 Mark for reverse action Color Code: Blue

Figure 2 : Protection Types

 <div style="border: 1px solid black; padding: 5px; display: inline-block; text-align: center;"> <p>! CAUTION</p> <p>This diagram does not consider safe diodes provided for on intrinsically safe devices designed for the European Standards.</p> </div>				
SIGNAL ⁽¹⁾ (mA)	CIRCUIT NOMINAL RESISTANCE (Ω)	COIL NOMINAL RESISTANCE (Ω)	COIL COLOR CODE	TERMINAL BOARD CODE
1-5 ⁽²⁾	2753	2230	RED	1
4-20	216	173	BLUE	4
10-50 ⁽²⁾	105	29	BLACK	7

1. Signal 4-20 mA only available in case of Ex ia protection.
2. No longer manufactured.

Figure 3 : Standard Circuits

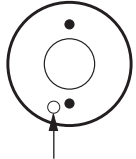
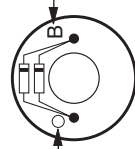
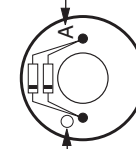
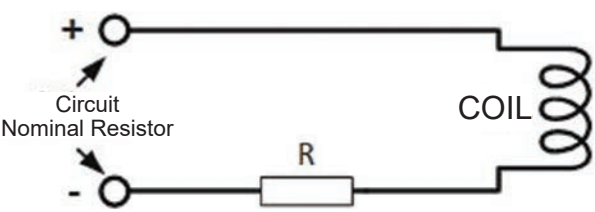
Standard Circuits

Model 8007 and 8008 transducers operate by now only with the 4-20mA signal. Others signals as shown in Figure 3 table are no longer maintained.

AIR PIPING

The transducer output and supply connections are screwed 1/4" NPT. They are located on the manifold (8007) or on the relay (8008) and marked with arrows.

Supply circuit

The utilization of an air filter-regulator model 78-4/78-40 is recommended on the supply circuit. Be sure that its assembly position is correct (drain-cock and dripwell downward).

Use 1/4" O.D. (6 X 8 mm dia.) brass tubing for the air line between air filter-regulator and transducer. For the supply of the air filter-regulator use 1/4" O.D. tubing (6 X 8 mm dia.).

Adjust the output pressure of the air filter-regulator to 1,586 bar (23 psi) for a 0,207 to 1,034 bar (3-15 psi) pneumatic output signal or to 2,413 bar (35 psi) for a 0,414 to 2,068 bar (6-30 psi) signal.

Output Circuit

The pneumatic output connection to the actuator should be particularly tight.

Note: Manifold or relay may be mounted in any one of four positions 90° apart to facilitate accessibility of supply and output connections. To change position or either, simply remove the four mounting screws and rotate to desired position. Insert and tighten the four screws.

Use 1/4" O.D. (6 X 8 mm dia.) brass tubing for the air line between transducer, booster relay or positioner (with 8007) and final control element (actuator of the control valve). (4 X 6 mm dia. with Varipak valve).

ZERO ADJUSTMENT CHECK

The transducer zero adjustment should be checked before the instrument is placed in service. Rough handling in shipment may shift the original adjustment. Refer to chapter "operation and adjustments".

Operation and Adjustments

WARNING

De-energize electric circuits before service or maintenance. Be sure that connections are correctly performed and that the cover is well placed on the case before energizing the circuits. Only qualified personnel to service this equipment.

Operation

The Masoneilan transducer is a force-balance Electro-Pneumatic device which converts a low power dc electrical signal into a proportional pneumatic output signal of 0,207-1,034 bar (3-15 psi) or 0,414-2,068 bar (6-30 psi).

Model 8007 is equipped with a manifold for transmission of a 0,207-1,034 bar (3-15 psi) pneumatic signal to a valve positioner or relay (volume booster).

Model 8008 has an integrally mounted relay to operate the final control element directly with either a 0,207-1,034 bar (3-15 psi) or 0,414-2,068 bar (6-30 psi) signal.

Direct action : With direct action an increase in the input signal of the transducer produces a force on the beam, causing it to move the ball into the nozzle. Nozzle back pressure is increased until the force exerted by it on the beam equals that exerted by the coil. The beam is thus rebalanced at an increased nozzle back pressure (i.e. output pressure) proportional to the increased electrical signal.

Reverse action : The coil leads to the terminal board are reversed and the transducer is calibrated so that an increase in input signal produces a decrease in output pressure (see paragraph “changing of action”).

Relay : The relay operates on the principle that air pressure on one side of the diaphragm must be balanced by an equal pressure on the other side. Supply air passes to the relay plug. A small quantity of this air also passes through the metering tube and serves as the nozzle supply. When nozzle pressure is greater than output pressure, the diaphragm assembly moves to allow the relay plug to seal the exhaust and open the inlet. Inlet remains open until equilibrium is reached between nozzle and output pressure. While equilibrium exists a small bleed between supply and output holds the relay plug slightly off the exhaust seat to increase the relay responsiveness.

When nozzle pressure is less than output pressure, the diaphragm assembly moves to allow the relay plug to close the inlet and open the exhaust, allowing output air to exhaust to atmosphere.

Zero Adjustment

The transducer is calibrated for the action and the dc input signal range specified. Any future change is either will necessitate recalibration of the instrument. To zero the transducer proceed as follows :

1. Use an accurate pressure gauge to measure output pressure and a current source.
2. Connect input signal leads. Connect coil leads to the terminal board for desired action (see “electrical circuit”). Apply mid-point of the input signal range (i.e. 3 mA if input signal range is 1 - 5mA).
3. With 1,586 bar (23 psi) or 2,413 bar (35 psi) to the supply connection, adjust the screw of the biasing spring (52) until output is 0,621 bar (9 psi) for 0,207 to 1,034 bar output (3-15 psi) or 1,241 bar (18 psi) for 0,414 to 2,068 bar output (6-30 psi).

Beam Balance Adjustment

The beam of the transducer has been balanced at the factory by adjusting the position of the weight (located on the beam above the terminal board). The position of the weight is marked with small dab of paint. Rebalancing of the beam is necessary only if the coil or beam is replaced or if the weight has been accidentally moved.

1. The first step is to zero the transducer as outlined above only using flexible plastic air tubing (Rilsan) for supply and output air lines. Set the transducer on a bench with the beam up and horizontal.
2. Apply mid-point of the signal input to the transducer and note the output pressure. The output pressure should be at mid-point of the output span.
3. Pick up the transducer, turn it upside down and again note the output pressure. If output pressure has changed less than 1% of the output span, the beam is balanced and no weight adjustment is required. If output increases more than 1%, loosen screw and move weight away from the pivot slightly. If output decreases more than 1%, move weight toward the pivot slightly. Re-tighten the screw.
4. Repeat Step 3 after weight has been moved to re-check beam balance.

Span Adjustment

Span adjustment is necessary only when an electrical component is replaced or for any reason the adjustments have been changed. To adjust the span, connect current input signal leads and proceed as follows :

1. With 1,586 bar (23 psi) or 2,413 bar (35 psi) to the supply connection and input signal at low limit of range, check output pressure reading.
2. Change input signal to high limit of range and check output pressure reading. Input signal change from low limit to high limit of range should produce an output change of 0,827 bar (12 psi) (0,207 to 1,034 bar, 3-15 psi range) or 1,655 bar (24 psi) (0,414 to 2,068 bar, 6-30 psi range).

3. If output range is something other than the above, remove the rear cover plate (24) then remove case plug and lightly unscrew lock screw. Turn span adjustment screw clockwise if the span is too narrow and counter clockwise if the span is too wide.
4. Tighten lock screw.

! CAUTION

Do not unscrew span adjustment screw more than necessary for calibration. Magnet strength starts to decrease after one full turn.

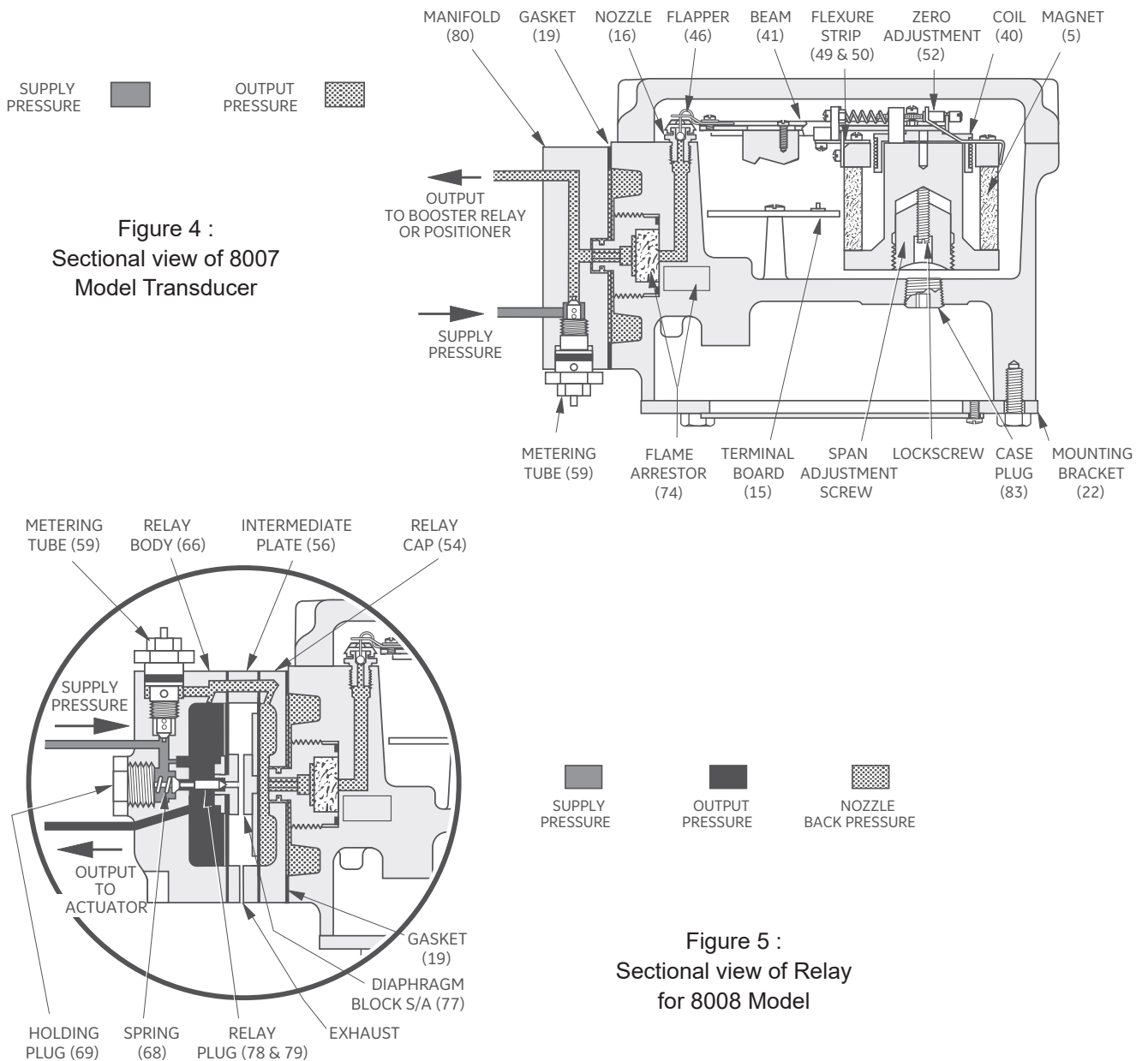

Maintenance (see parts reference on page 15)

! WARNING

De-energize electric circuits before service or maintenance. Be sure that connections are correctly performed and that the cover is well placed on the case before energizing the circuits. Only qualified personnel to service this equipment.

Metering Tube

The metering tube (59) for the nozzle air supply is furnished with a clean-out plunger which forces a small wire through the jewel orifice. The metering assembly can be removed and checked prior to relay disassembly.

Relay Disassembly (8008 only)

1. Disconnect air tubing. Unscrew the four relay mounting screws (21) and remove relay from the case (14).
2. Remove holding screw (69) and drop the plug (79) and spring (68) from the relay body (66).
3. Remove the six screws (53) which hold the relay cap (54), diaphragm (55), intermediate plate (56) and diaphragm block S/A (77) to the relay body (66). Clean parts with a clean soft cloth. Use solvent if oil or grease is present (do not use solvent on diaphragms). Blow out parts with clean dry air. Replace all damaged parts.

Relay Reassembly (8008 only)

1. Replace diaphragm (55) and diaphragm block S/A (77) on the intermediate plate (56). Align holes in diaphragms with those of the relay body, intermediate plate and cap (54). Correct alignment is simplified by use of external reference marks. Replace six screws (53).
2. Assemble relay plug (79), spring (68) and holding screw (69). Establish correct relay position and fasten relay with gasket (19) to the transducer case. Hardly tighten (contact +1/4 turn) the 4 screws (21). If relay repairs are required, it is recommended that a new relay (20) be installed to minimize time out of service.

Nozzle (8007 & 8008)

To clean nozzle (16) shut off the air supply ; loosen screw (45) and remove wire flapper (46) from beam (41). Unscrew nozzle.

! CAUTION

Do not remove plastic cap on nozzle, as this cap retains the ruby colored ball.

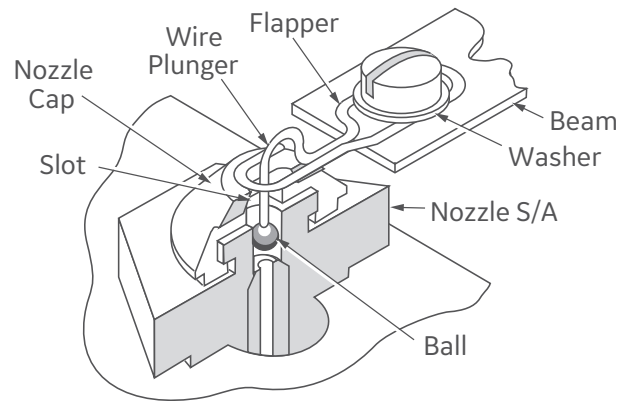

Figure 6 : Nozzle and flapper system

Immersion of the entire nozzle assembly in a solvent (compatible with Delrin) is recommended. If this does not satisfactorily clean the nozzle, remove the plastic cap using extreme caution so as not to lose the ruby colored ball. After cleaning, replace nozzle assembly in case. Secure nozzle, but do not over-tighten so as to strip threads. Replace wire flapper and align flapper as described on page 13 under “calibration”.

! WARNING

Avoid breathing of solvent vapors and contact with skin. Follow solvent manufacturer’s recommendations for usage.

Circuit Board Replacement

1. Remove transducer cover and disconnect coil leads from the terminal board. Remove wire flapper. Remove two mounting screws (4) and lift the entire operating mechanism from the case.
2. Disconnect input signal leads from terminal board. Remove two screws (9) holding terminal board. Install new terminal board and tighten two screws (9).
3. Connect input signal leads to terminal board respecting the polarities.
4. Replace operating mechanism in case with two screws (4). Check to insure zeroing spring bracket is properly held by one of screws (4). Connect coil leads to terminal board according to transducer action required.

- Replace wire flapper and align as described in steps 1 and 2 of calibration procedure (page 13).
- Complete steps 3 through 9 of calibration procedure.

Flexure Strip Replacement

- Remove transducer cover and disconnect coil leads from the terminal board. Remove two mounting screws (4) and lift the entire operating mechanism from the case.
- Remove screws (42) and flexure strips (49) and (50) from the beam. Replace coil if necessary per instructions below.
- Replace damaged flexure strips and reattach beam to the magnet with flexure strips and screws (42). Do not tighten screws. Align the beam per instructions below.

Coil Replacement

- Remove the entire operating mechanism as described in steps 1 and 2 above. Unscrew screws (44 and 45) freeing force coil (40) from the beam.
- Attach replacement force coil loosely to the beam with screws (44) and (45).

Note : *coil stop screw (44) should not extend into the coil bobbin.*

- Reattach beam to magnet with flexure strips and screws and align the beam per instructions below.

Beam Alignment (Figure 7)

- Insert a 1/8" (3,175mm) diameter rod into alignment holes in the coil, beam and magnet and place on the magnet, between the beam and the coil, a wedge 5/32" (3,97 mm) high and 1/32" (1 mm) maxi in thickness. Rod and wedge materials should be non-magnetic.
- Tighten two screws (42) of inner flexure strip to beam ; two screws of outer flexure strip to magnet.
- Remove wire flapper from beam. Replace operating mechanism in case and tighten in position with two mounting screws (4). Replace biasing spring bracket under mounting screws as shown below).
- Lightly exert downward force on beam directly above coil and adjust stop screw (44) (with locknut (43) loose), until beam is parallel with top surface of case. While maintaining light downward force on beam (above coil) tighten remaining 4 screws of flexures.
- Tighten the force coil screw (45) and remove alignment rod and wedge.
- Replace wire flapper and align as described in steps 1 and 2 of "calibration" procedure.
- Complete steps 3 through 9 of calibration procedure.

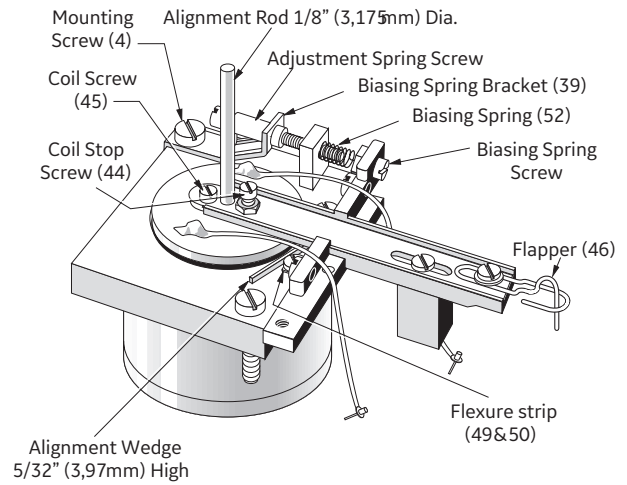

Figure 7 : Beam Alignment

Calibration

Calibration is required if any components have been replaced or if for any reason one or more of the adjustments has been altered.

CAUTION

Do not remove plastic cap on nozzle. This cap retains the ruby colored ball and removal of cap will result in loss of the ball.

- Inspect nozzle cap to insure slot in top of nozzle cap is parallel with beam as shown in Figure 6. If cap is not parallel with beam, carefully rotate nozzle cap until slot in top of cap is parallel with beam as shown.
- Inspect wire flapper to insure wire plunger is centered in nozzle cap slot, and hole in nozzle as shown in Figure 6.
- Adjust air supply to 1,586 bar (23 psi) for a 0,207 to 1,034 bar (3-15 psi) pneumatic output signal or to 2,413 bar (35 psi) for a 0,414 to 2,068 bar (6-30 psi) signal.
- Gently depress coil with finger and adjust stop (44) until output is between 0,069 and 0,103 bar (1 and 1,5 psi). Tighten lock nut to retain stop adjustment.
- Gently depress flapper against nozzle cap and observe output build up. Output should build up to 1,448 bar (21 psi) with 1,586 bar (23 psi) supply 2,276 bar (33 psi) with 2,413 bar (35 psi supply).
- Check beam balance as described on page 10.
- "Zero" the output pressure as described on page 10.
- Check beam balance as described on page 10.
- Replace cover and put into service.

Troubleshooting

WARNING

De-energize electric circuits before service or maintenance. Be sure that connections are correctly performed and that the cover is well placed on the case before energizing the circuits. Only qualified personnel to service this equipment.

The following conditions are necessary for trouble-free operation :

1. Proper air supply pressure, i.e. 1,586 bar (23 psi) or 2,413bar (35 psi) clean air.
2. Proper electrical circuit for input signal.
3. All components fastened firmly as required.
4. Beam stop properly positioned.
5. Proper “wire flapper” alignment.
6. Tight output circuit (no leaks)

Air circuit

In the event of faulty operation of the transducer, where the cause is not readily apparent, isolate the transducer from the control loop and check the air system as follows :

1. With 1,586 bar (23 psi) or 2,413 bar (35 psi) to the transducer, check that output pressure falls to at least 0,103 bar (1,5 psi) when the flapper is lightly held off the nozzle.
2. Exert light force on the flapper to cover the nozzle. Output should build up to 1,448 bar (21 psi) or 2,276 bar (33 psi).
3. If response is other than indicated in the above steps, push cleanout plunger in the metering tube (59). Inspect for dirty nozzle (16). Inspect for missing ball. Check to see that the metering tube (59) is properly seated in the relay or manifold body. If difficulty still persists, disassemble the relay (see maintenance).
4. If transducer will not repeat, inspect for foreign particles between coil and magnet.
5. After checking the air system, check the transducer electrical circuit. Accurately measure the resistance of the circuit. If the difficulty is still not apparent, inspect each individual component.

Electrical Circuit

After checking the pneumatic circuit, the electrical circuit should be checked with an ohmmeter as follows :

1. Disconnect controller signal leads from the terminal board.
2. Connect ohmmeter leads to the transducer terminal board and check the circuit resistance (see nominal input resistance, on table page 4 or on serial plate of transducer).
3. Disconnect one of the coil leads from the transducer terminal and connect it to one of the ohmmeter leads. Connect the other ohmmeter lead to the other coil lead. Force coil resistance value should approximate the value indicated on page 8.
4. If the force coil resistance is approximately correct but transducer circuit resistance is not, replace the terminal board (15). If the force coil resistance is not correct, replace the force coil (40).
5. Connect one of the ohmmeter leads to coil stop screw (44) and the other to one of the coil leads. Check for a short in the force coil. Replace force coil if the ohmmeter indicates a value other than infinite resistance.

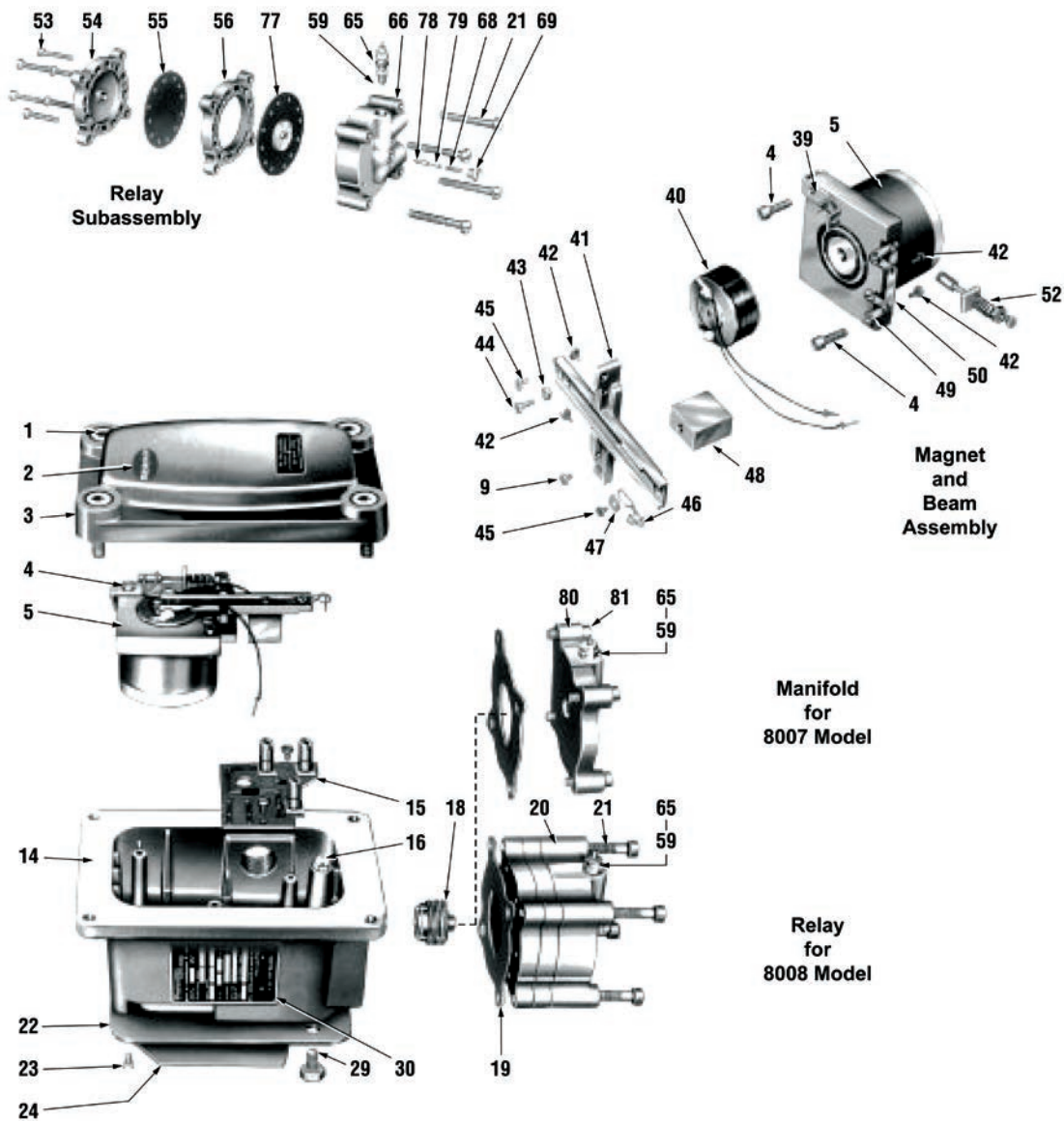

Parts Reference

Ref No.	Part Name	Ref. No.	Part Name	Ref. No.	Part Name
1	Cover Screw	29	Cap Screw	54	Relay Cap
2	Emblem	30	Serial Plate	● 55	Diaphragm
3	Cover	39	Biasing Spring Bracket	56	Intermediate Plate
4	Mounting Screw (Magnet)	● 40	Coil	● 59	Metering Tube S/A
5	Magnet S/A	41	Beam	● 65	O-Ring
9	Screw	42	Screw (Flexure Strips)	66	Relay Body
14	Case	43	Stop Locknut	68	Plug Spring
● 15	Terminal Board S/A	44	Coil Stop Screw	69	Holding Plug
16	Nozzle (Includes cap and ball)	45	Screw (Fastening Coil & Flapper)	❖ 74	Flame Arrestor
❖ 18	Adapter (Flame arrestor)	46	Flapper	● 77	Diaphragm Block S/A
● 19	Gasket	47	Washer	78	Plug Adapter
● 20	Relay	48	Counter-Weight	79	Inlet Plug
21	Mounting Screw (Relay)	● 49	Flexure-Strip	80	Manifold
22	Mounting Bracket	● 50	Flexure-Strip	81	Mounting Screw (manifold)
23	Screw	52	Biasing Spring (Zero Adjustment)	83	Case Plug
24	Cover Plate	53	Mounting Screw (Relay)		

● Recommended Spare Parts

❖ These parts should not be purchased separately as they are staked or press fitted into the case (14).

Find the nearest local Channel Partner in your area:

valves.bakerhughes.com/contact-us

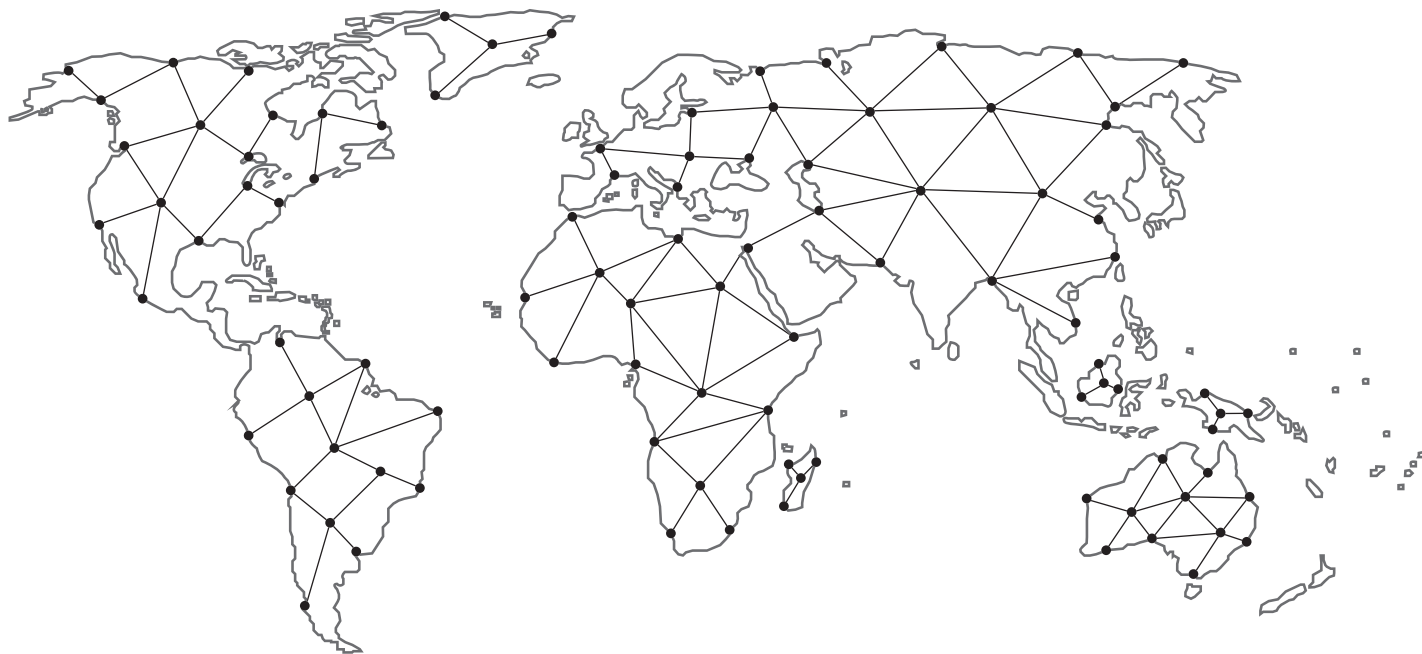

Tech Field Support & Warranty:

Phone: +1-866-827-5378

valvesupport@bakerhughes.com

valves.bakerhughes.com

Copyright 2023 Baker Hughes Company. All rights reserved. Baker Hughes provides this information on an "as is" basis for general information purposes. Baker Hughes does not make any representation as to the accuracy or completeness of the information and makes no warranties of any kind, specific, implied or oral, to the fullest extent permissible by law, including those of merchantability and fitness for a particular purpose or use. Baker Hughes hereby disclaims any and all liability for any direct, indirect, consequential or special damages, claims for lost profits, or third party claims arising from the use of the information, whether a claim is asserted in contract, tort, or otherwise. Baker Hughes reserves the right to make changes in specifications and features shown herein, or discontinue the product described at any time without notice or obligation. Contact your Baker Hughes representative for the most current information. The Baker Hughes logo and Masoneilan are trademarks of Baker Hughes Company. Other company names and product names used in this document are the registered trademarks or trademarks of their respective owners.

Baker Hughes 

bakerhughes.com