

3300 XL High-Pressure Feedthrough

Datasheet

Bently Nevada Machinery Condition Monitoring

141622 Rev. F

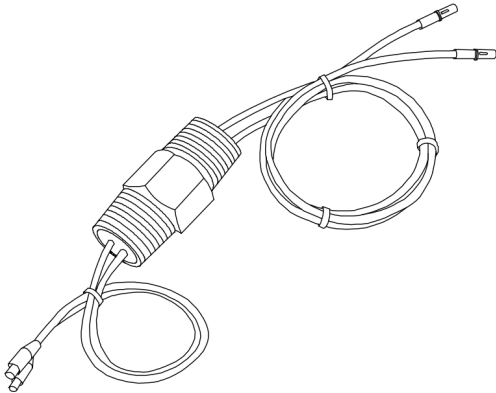

Description

This product allows placement of 3300 XL 8 mm probes, 3300 XL 11 mm, and 3300 5 mm probes in pressurized machines.

Some rotating machines have significant differential pressure between the inside of the machine case and ambient conditions where the extension cable exits. Since proximity probes are mounted inside the pressurized area, a safe, convenient way to route the probe cable through the case is essential. Depending upon the pressure, a cable seal or High-Pressure (HP) Feedthrough is used to seal pressure inside the machine case and allow probe connections outside the case.

Three models of the 3300 XL 8 mm Series High-Pressure Feedthrough are available which can route 1, 2, or 3 cables through the case. One model of the 3300 XL 11 mm Series High-Pressure Feedthrough is available which can route 2 cables through the case. These models seal 2.76 MPa (400 psi) inside the machine. They are ordered according to the total length of the Proximitor sensor so that system electrical length is maintained.

When ordering, careful consideration should be given to the type of O-ring specified. The O-ring must be compatible with the type of gas or fluid that the cable will be exposed to in the machine.

In addition, since these feedthroughs are used in place of probe extension cables, the high pressure end is usually supplied with female connectors and the low pressure end with male connectors. This permits compatibility with standard probes and Proximitor Sensors. The connectors are corrosion-resistant, gold-plated brass ClickLoc connectors. These connectors require only finger-tight torque when mated to 3300 XL Proximitor Sensors or ClickLoc connectors on 3300 XL 8 mm probes, 3300 XL 11mm, or 3300 5 mm probes.

We can also offer modified feedthroughs, which can seal up to 6.89 MPa (999 psi). Contact your sales representative for

more information on these products.
Bently.com

Specifications

Operating Temperature

 Temperature range depends on O-Ring Option

7 9	-51°C to 121°C (-60°F to 250°F)
8 4	-43°C to 121°C (-45°F to 250°F)
9 4	-26°C to 121°C (-15°F to 250°F)
Maximum Pressure Rating	2.76 MPa (400 psi).
Humidity	100% non-condensing

 The cable to feedthrough interface should be protected from exposure to water. The Bently Nevada High Pressure Feedthrough is not designed or intended to seal water away from its internal cable leads. If the cable to Feedthrough interface is exposed to water (LP & HP sides), the water can migrate into the cable lead area of the feedthrough and create a high resistance electrical short that will significantly reduce the output of the transducer system.

Minimum Recommended Bend Radius	25.4 mm (1.00in) with or without armor.
Fitting Material	303 stainless steel.

 Beware that the feedthrough length ordered must be compatible with the total transducer system length being used.

Ordering Information



For the detailed listing of country and product specific approvals, refer to the *Approvals Quick Reference Guide* (108M1756) available from Bently.com.

330161 Single Triaxial HP Feedthrough for 3300 System

330161-AA-BB-CC-DD-EE-FF

A: Armor Option

0 1	Without armor
0 2	With armor at low pressure end
0 3	With armor at high pressure end
0 4	With armor at both ends

B: Dimension 1 Length Option

4 0	4.0 metres
4 5	4.5 metres
8 0	8.0 metres
8 5	8.5 metres

C: Dimension 2 Length Option

Order in increments of 0.1 metre.

Minimum ordering length	0.5 metre.
Maximum ordering length	Dimension 1 (B option) minus 0.5 metre.

D: O-Ring Material Option

7 9	Ethylene propylene, for exposure to ammonium hydroxide, carbon dioxide, chlorine, nitrogen, gaseous oxygen and steam
8 4	Neoprene, for exposure to R-12 or R-134A refrigerants
9 4	Fluorocarbon, for exposure to butane, fuel oil, natural gas, petroleum oil, and turbine oil.

E: High Pressure End Connector Option

0 0	Without connector
0 1	With female miniature coaxial connector
0 2	With male miniature coaxial connector



For proper connection, the connector on the probe side must be female and the connector on the Proximitor Sensor side must be male.

F: Low Pressure End Connector Option

0 0	Without connector
0 1	With female miniature coaxial connector
0 2	With male miniature coaxial connector



For proper connection, the connector on the probe side must be female and the connector on the Proximitor Sensor side must be male.

330162 Dual Triaxial HP Feedthrough for 3300 System

330162-AA-BB-CC-DD-EE-FF-GG-HH

A: Armor Option

0 1	Without armor
0 2	With armor at low pressure end
0 3	With armor at high pressure end
0 4	With armor at both ends

B: Dimension 1 Length Option

4 0	4.0 metres
4 5	4.5 metres
8 0	8.0 metres
8 5	8.5 metres

C: Dimension 2 Length Option

4 0	4.0 metres
4 5	4.5 metres
8 0	8.0 metres
8 5	8.5 metres

D: Dimension 3 Length Option

Order in increments of 0.1 metre.

Minimum ordering length	0.5 metre.
Maximum ordering length	Dimension 1 (B option) minus 0.5 metre.

E: Dimension 4 Length Option

Order in increments of 0.1 metre.

Minimum ordering length	0.5 metre.
Maximum ordering length	Dimension 2 (C option) minus 0.5 metre.

F: O-Ring Material Option

7 9	Ethylene propylene, for exposure to ammonium hydroxide, carbon dioxide, chlorine, nitrogen, gaseous oxygen and steam
8 4	Neoprene, for exposure to R-12 or R-134A refrigerants
9 4	Fluorocarbon, for exposure to butane, fuel oil, natural gas, petroleum oil, and turbine oil.

G: High Pressure End Connector Option

0 0	Without connector
0 1	With female miniature coaxial connector
0 2	With male miniature coaxial connector

 For proper connection, the connector on the probe side must be female and the connector on the Proximitor Sensor side must be male.

H: Low Pressure End Connector Option

0 0	Without connector
0 1	With female miniature coaxial connector
0 2	With male miniature coaxial connector

 For proper connection, the connector on the probe side must be female and the connector on the Proximitor Sensor side must be male.

330163 Triple Triaxial HP Feedthrough for 3300 System

330163-AA-BB-CC-DD-EE-FF-GG-HH-II-JJ

A: Armor Option

0 1	Without armor
0 2	With armor at low pressure end
0 3	With armor at high pressure end
0 4	With armor at both ends

B: Dimension 1 Length Option

4 0	4.0 metres
4 5	4.5 metres
8 0	8.0 metres
8 5	8.5 metres

C: Dimension 2 Length Option

4 0	4.0 metres
4 5	4.5 metres
8 0	8.0 metres
8 5	8.5 metres

D: Dimension 3 Length Option

4 0	4.0 metres
4 5	4.5 metres
8 0	8.0 metres
8 5	8.5 metres

E: Dimension 4 Length Option

Order in increments of 0.1 metre.

Minimum ordering length	0.5 metre
Maximum ordering length	Dimension 1 (B option) minus 0.5 metre.

F: Dimension 5 Length Option

Order in increments of 0.1 metre.

Minimum ordering length	0.5 metre.
Maximum ordering length	Dimension 2 (C option) minus 0.5 metre.

G: Dimension 6 Length Option

Order in increments of 0.1 metre.

Minimum ordering length	0.5 metre.
Maximum ordering length	Dimension 3 (D option) minus 0.5 metre.

H: O-Ring Material Option

7 9	Ethylene propylene, for exposure to ammonium hydroxide, carbon dioxide, chlorine, nitrogen, gaseous oxygen and steam
8 4	Neoprene, for exposure to R-12 or R-134A refrigerants
9 4	Fluorocarbon, for exposure to butane, fuel oil, natural gas, petroleum oil, and turbine oil.

I: High Pressure End Connector Option

0 0	Without connector
0 1	With female miniature coaxial connector
0 2	With male miniature coaxial connector

 For proper connection, the connector on the probe side must be female and the connector on the Proximito Sensor side must be male.

J: Low Pressure End Connector Option

0 0	Without connector
0 1	With female miniature coaxial connector
0 2	With male miniature coaxial connector

 For proper connection, the connector on the probe side must be female and the connector on the Proximito Sensor side must be male.

330762 Dual Triaxial HP Feedthrough for 3300 XL 11mm System

330762-AA-BB-CC-DD-EE-FF-GG-HH

A: Armor Option

0 1	Without armor
0 2	With armor at low pressure end
0 3	With armor at high pressure end
0 4	With armor at both ends

B: Dimension 1 Length Option

4 0	4.0 metres
8 0	8.0 metres

C: Dimension 2 Length Option

4 0	4.0 metres
8 0	8.0 metres

D: Dimension 3 Length Option

Order in increments of 0.1 metre.

Minimum ordering length	0.5 metre.
Maximum ordering length	Dimension 1 (B option) minus 0.5 metre.

E: Dimension 4 Length Option

Order in increments of 0.1 metre.

Minimum ordering length	0.5 metre.
Maximum ordering length	Dimension 2 (C option) minus 0.5 metre.

F: O-Ring Material Option

7 9	Ethylene propylene, for exposure to ammonium hydroxide, carbon dioxide, chlorine, nitrogen, gaseous oxygen and steam
8 4	Neoprene, for exposure to R-12 or R-134A refrigerants
9 4	Fluorocarbon, for exposure to butane, fuel oil, natural gas, petroleum oil, and turbine oil.

G: High Pressure End Connector Option

0 0	Without connector
-----	-------------------

0 1	With female miniature coaxial connector
0 2	With male miniature coaxial connector

 For proper connection, the connector on the probe side must be female and the connector on the Proximito Sensor side must be male.

H: Low Pressure End Connector Option

0 0	Without connector
0 1	With female miniature coaxial connector
0 2	With male miniature coaxial connector

 For proper connection, the connector on the probe side must be female and the connector on the Proximito Sensor side must be male.

Graphs and Figures

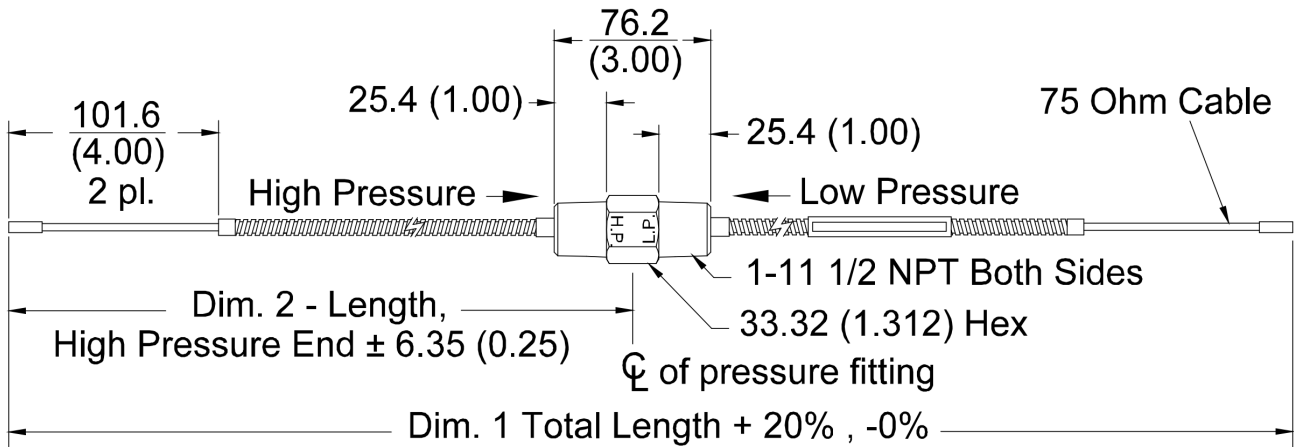

Figure 1: Part Number 330161 Single Feedthrough

Dimensions are in millimetres (inches)

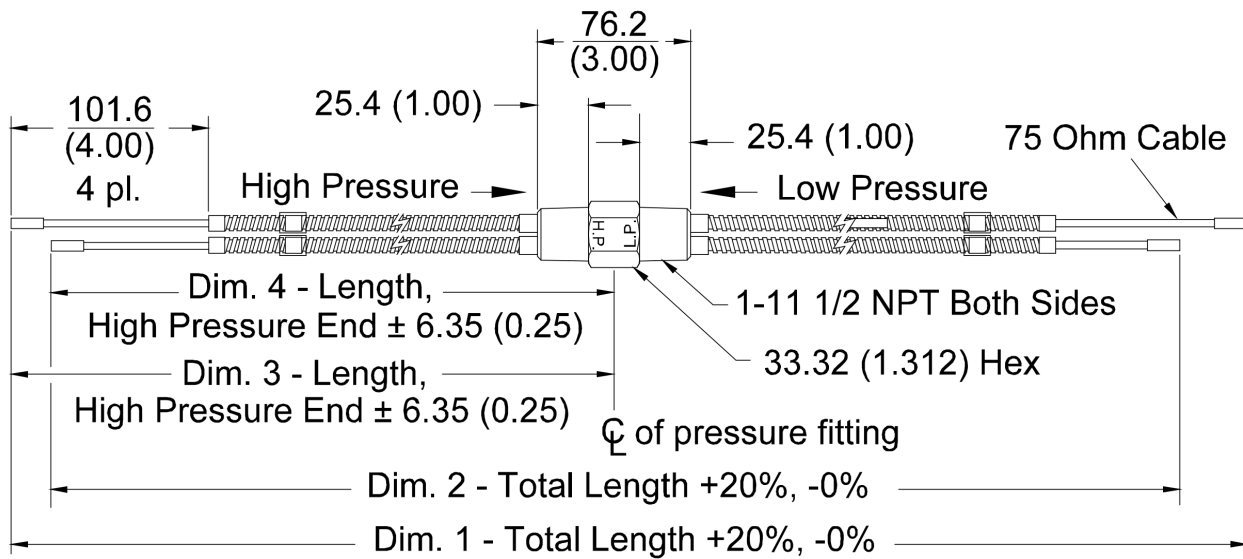

Figure 2: Part Number 330162 Dual Feedthrough

Dimensions are in millimetres (inches)

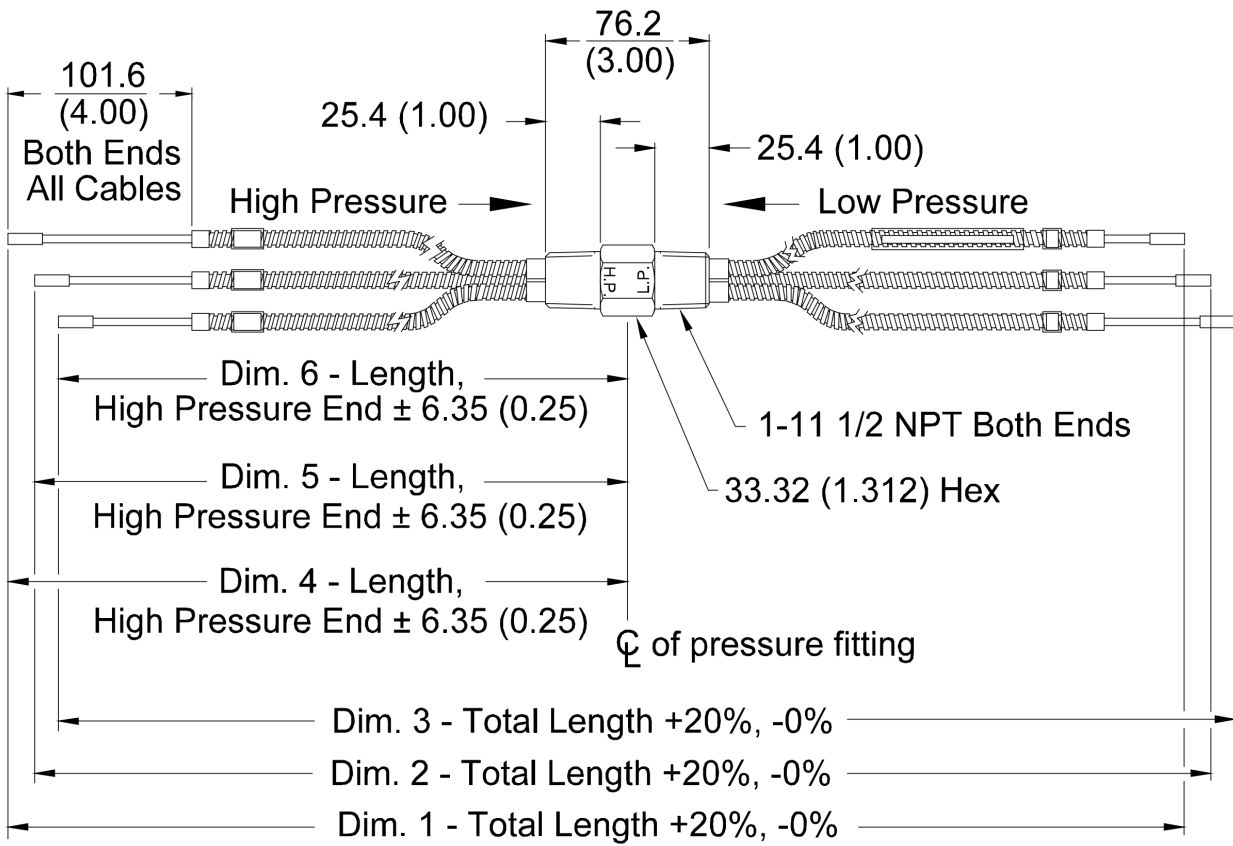

Figure 3: Part Number 330163 Triple Feedthrough

Dimensions are in millimetres (inches)

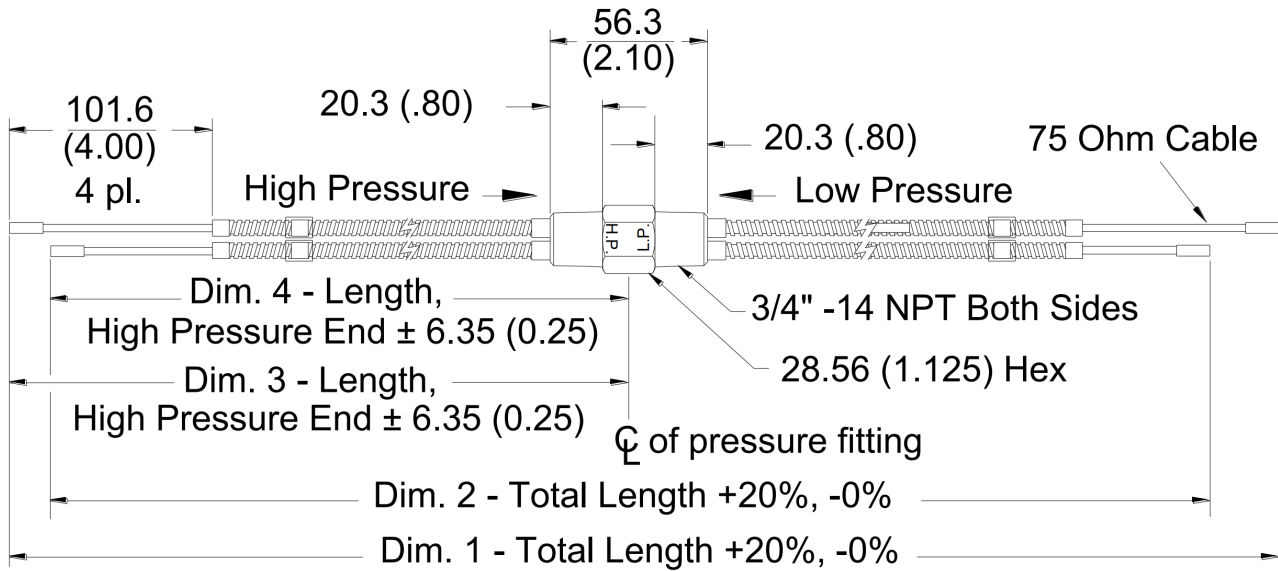

Figure 4: Part Number 330762 Dual Feedthrough, 3300 XL 11mm System

Dimensions are in millimetres (inches)

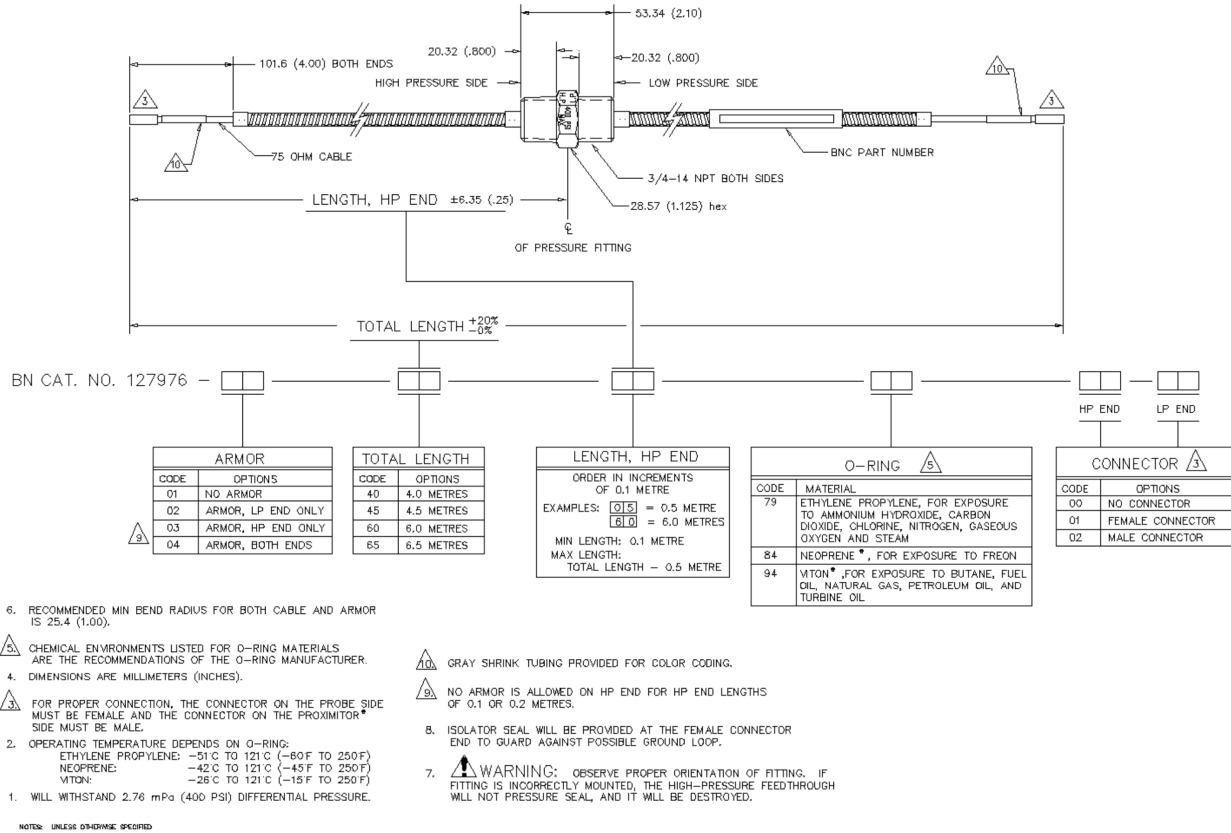

Figure 5: Part Number 127976, High Pressure Feedthrough Single Cable NSv System
 Dimensions are in millimetres (inches)

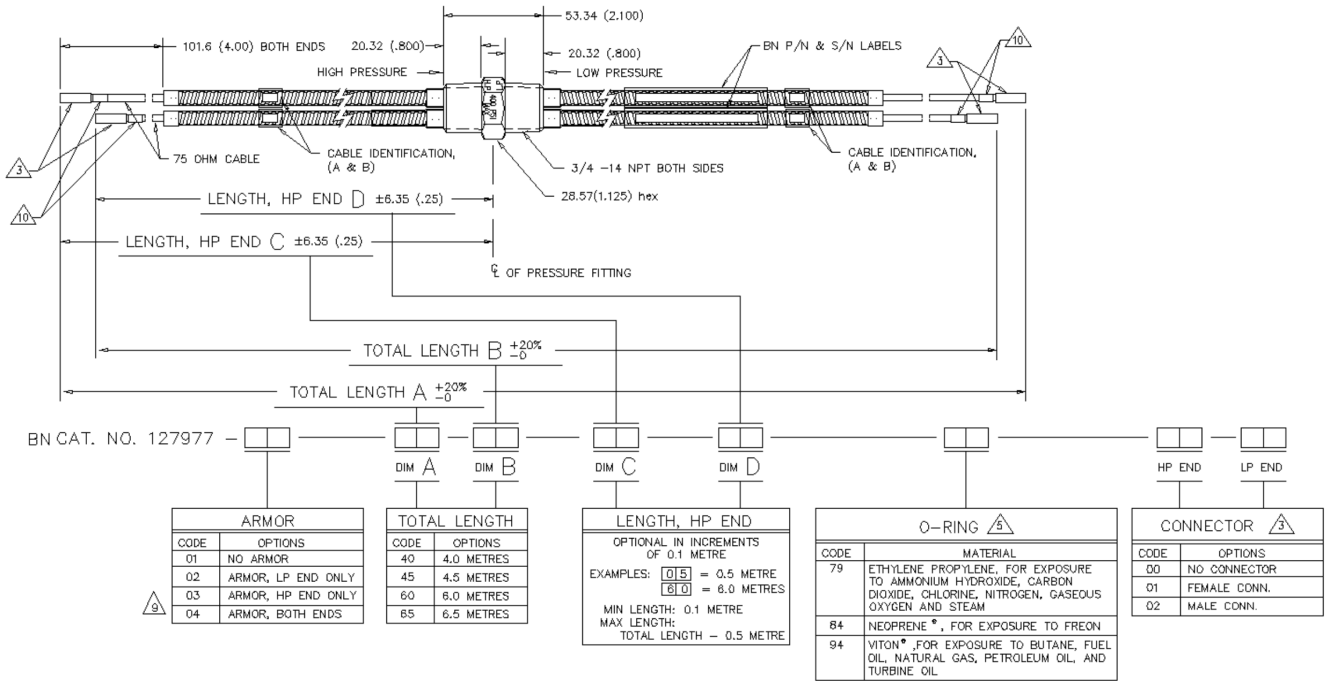

Figure 6: Part Number 127977, High Pressure Feedthrough Dual Cable NSv System

Dimensions are in millimetres (inches)

Copyright 2020 Baker Hughes Company. All rights reserved.



Bently Nevada, Orbit Logo and Proximitor are registered trademarks of Bently Nevada, a Baker Hughes Business, in the United States and other countries. The Baker Hughes logo is a trademark of Baker Hughes Company. All other product and company names are trademarks of their respective holders. Use of the trademarks does not imply any affiliation with or endorsement by the respective holders.

Baker Hughes provides this information on an "as is" basis for general information purposes. Baker Hughes does not make any representation as to the accuracy or completeness of the information and makes no warranties of any kind, specific, implied or oral, to the fullest extent permissible by law, including those of merchantability and fitness for a particular purpose or use. Baker Hughes hereby disclaims any and all liability for any direct, indirect, consequential or special damages, claims for lost profits, or third party claims arising from the use of the information, whether a claim is asserted in contract, tort, or otherwise. Baker Hughes reserves the right to make changes in specifications and features shown herein, or discontinue the product described at any time without notice or obligation. Contact your Baker Hughes representative for the most current information.

The information contained in this document is the property of Baker Hughes and its affiliates; and is subject to change without prior notice. It is being supplied as a service to our customers and may not be altered or its content repackaged without the express written consent of Baker Hughes. This product or associated products may be covered by one or more patents. See [Bently.com/legal](https://www.bently.com/legal).

1631 Bently Parkway South, Minden, Nevada USA 89423
Phone: 1.775.782.3611 or 1.800.227.5514 (US only)
[Bently.com](https://www.bently.com)