



Everest Ca-Zoom HD

Product catalog

Everest Ca-Zoom HD product catalog

Introducing the Everest Ca-Zoom HD, Waygate Technologies' most advanced line of pan-tilt-zoom cameras, delivering the highest resolution images for thorough and accurate visual inspections.

We go beyond just cameras. To maximize your inspection efficiency and ensure crew safety, we offer a comprehensive range of cords and accessories designed for demanding environments.

Whether working in a vessel, mine, or nuclear reactor, our accessories empower skilled technicians to perform easier, safer, and more efficient inspections.

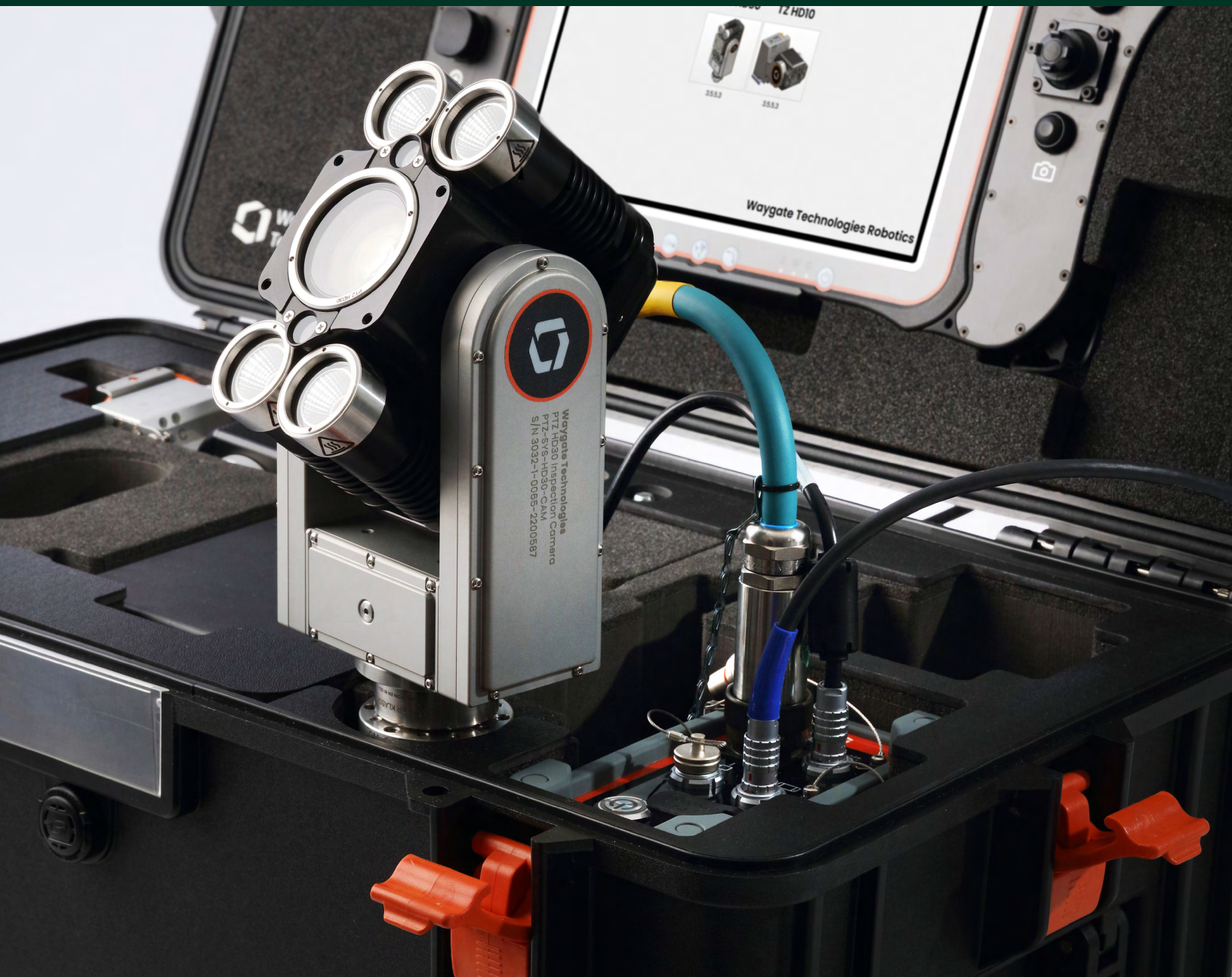

Everest Ca-Zoom system kits

Basic Kit

- System Case
PTZ-ACC-CASE
- HD 30 Camera Head
PTZ-ACC-HD30

All other base items

- Control Pendant
PTZ-ACC-PNDNT
- Pendant Cable
PTZ-ACC-PNDNT-C5M
- Camera Controller
PTZ-ACC-CCU
- Tool Box
PTZ-ACC-TOOLBOX
- Power Module
PTZ-ACC-CORD
- Pole Mount
PTZ-ACC-POLEMNT

TZ1 Kit

- TZ1 HD Camera
BIKE-ACC-TZ1-CAM

With Cables



- 10M Cable for HD30
PTZ-ACC-C10M
- 10M Cable for TZ1
TZ1-ACC-C10M

Everest Ca-Zoom HD kits

	HD30 Camera head	HD30 Camera head + TZ1
With camera cable	<p>PTZ-SYS-HD30-C Ca-Zoom HD PTZ30 kit</p>	<p>PTZ-SYS-HD30-TZ1-C Ca-Zoom HD PTZ30 + TZ1 kit</p>
Order your own camera cable	<p>PTZ-SYS-HD30 Ca-Zoom HD PTZ30 kit w/o cable</p>	<p>PTZ-SYS-HD30-TZ1 Ca-Zoom HD PTZ30 + TZ1 kit w/o cable</p>

Core components

Camera heads

	Part number	Component	Description
	PTZ-SYS-HD30-CAM	PTZ HD30 inspection camera	HD Inspection Camera PTZ HD30 <ul style="list-style-type: none"> • Anodized aluminum body • 30x optical zoom / 12x digital zoom • 1080i/60 Full-HD resolution • 2D/3D Noise reduction and visibility - enhancer with de-fog feature • 4x integrated LED (20W each) • Infinite pan (slipping) / 220° tilt • Integrated parallel line lasers for size estimation
	BIKE-ACC-TZI-CAM	TZI HD Inspection Camera	HD miniature tilt-zoom inspection camera for mounting on top of BIKE platform. <ul style="list-style-type: none"> • Integrated high power lights 2x Spot LEDs (390lm each) / 2x Flood LEDs (187 lm each), total 1154lm • Integrated parallel laser for size estimation • Tilt range: +123° to -104° • Resolution: Full HD 1920x1080 1/3" Sensor • Lens: 10x Optical Zoom, f = 3.3mm to 33.0mm • Horizontal view angle: 59.2 degree (wide end) to 6.7 degree (tele end) • Focus Control: Auto / Manual • Minimum Focus distance: 10mm at optical wide end / 800mm at optical tele end. • Weight: 930g / 2.05 lbs

Pendant

	PTZ-ACC-PNDNT	Ca-Zoom HD Pendant	Ca-Zoom HD Control Pendant <ul style="list-style-type: none"> • Screen: 10.1" WUXGA (1920x1200), 800cd/m², multitouch, glove firendly, stylus • Specs: Intel Core i5, 8GB DDR3L SDRAM, 256GB SSD • Control: hardware buttons for main functions (pan/tilt, zoom, light, capture, video record) • Software: Windows IoT, Camera control application • I/O: GBit Ethernet, 2x USB-A, HDMI • AC adapter: 100-240VAC, 180W, 50-60Hz • Four point shoulder harness • Weight: 1.63kg
	PTZ-ACC-HRNS	Ca-Zoom HD Pendant Shoulder Harness	Four Point Shoulder Harness for Ca-Zoom HD Control Pendant

CCU

	PTZ-ACC-CTRLBOX	Ca-Zoom HD cam controller	Ca-Zoom HD cam controller <ul style="list-style-type: none"> • Power Supply and Control Interface for all Camera heads • I/O: GBit Ethernet, Pendant connector, PTZ HD30 & TZI HD connector • AC adapter: 100-240VAC, 150W, 50-60Hz • Weight: 1.3kg • Dimensions: 167 x 164 x 90 mm (6.57 x 6.46 x 3.54 in)
---	-----------------	---------------------------	--

Tool box

	PTZ-ACC-TOOLBOX	PTZ HD tool box	Tool box <ul style="list-style-type: none"> • Allen keys for pole mount and pressurization valve • Screws for pole mount • Cloth for lens cleaning
---	-----------------	-----------------	---

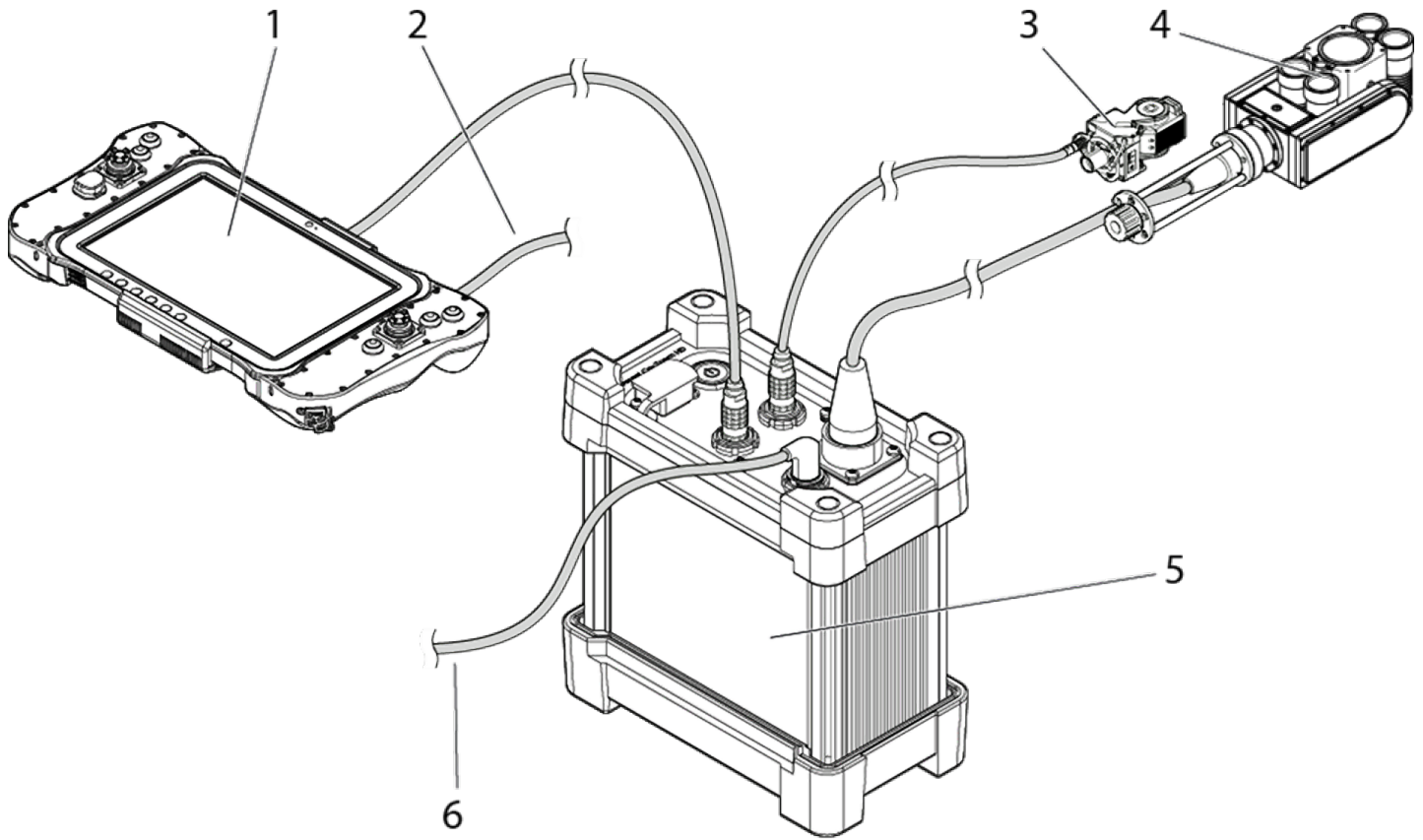

Cord guide



Number	Description	Part number
1 - 5	Pendant cable:	PTZ-ACC-PNDNT-C5M
2	HDMI cable (optional):	XA-HDMI
3 - 5	TZI HD camera cable:	TZI-ACC-C10M, TZI-ACC-C30M
4 - 5	PTZ HD30 camera cable:	PTZ-ACC-C10M, PTZ-ACC-C30M, PTZ-ACC-C70M
6	Power cable:	PTZ-ACC-CORD-EU, PTZ-ACC-CORD-UK, PTZ-ACC-CORD-US, PTZ-ACC-CORD-AUS

Cords

HD30

	Part number	Component	Description
	PTZ-ACC-C10M	PTZ HD30 - camera cable 10m/30ft	PTZ HD30 - Inspection camera cable 10m/30ft • Weight: 2.1kg
	PTZ-ACC-C30M	PTZ HD30 - camera cable 30m/100ft	PTZ HD30 - Inspection camera cable 30m/100ft on cable reel • 67.5m camera cable/ 2.5m connecting cable • Weight: 7.1kg
	PTZ-ACC-HD30-C70M	PTZ HD30 - camera cable 70m/230ft	PTZ HD30 - Inspection camera cable 70m/230ft • Cable reel with integrated slip ring to connect to interface box • 65m camera cable/ 5m connecting cable

TZ1

	TZ1-ACC-C10M	TZ1 HD - camera cable 10m/33ft	10m (33ft) camera cable for TZ1 inspection camera. Connects TZ1 HD camera directly to Ca-Zoom HD cam controller for standalone use.
	TZ1-ACC-C30M	TZ1 HD - camera cable 30m/100ft	30m (100ft) camera cable for TZ1 inspection camera. Connects TZ1 HD camera directly to Ca-Zoom HD cam controller for standalone use • Delivered on cable reel

Pendant cable

	PTZ-ACC-PNDNT-C5M	Pendant cable 5m/16.5 ft	Pendant cable to connect Ca-Zoom HD Control box to Pendant 5m/16.5 ft
---	-------------------	--------------------------	---

Power Cables

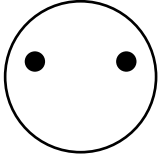
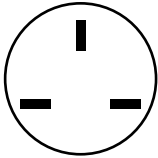
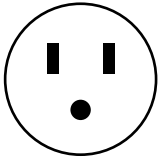
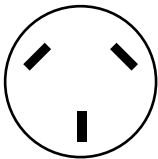

Power cables

	Part number	Component	Description
	PTZ-ACC-CORD-EU	Mains power cord C13 EU	Mains power cord C13 Type F/E • Everywhere in Europe & Russia, except for the UK & Ireland
	PTZ-ACC-CORD-UK	Mains power cord C13 UK	Mains power cord C13 Type G • United Kingdom, Ireland, Malta, Malaysia, Singapore & the Arabian Peninsula
	PTZ-ACC-CORD-US	Mains power cord C13 US	Mains power cord C13 Type B • USA, Canada, Mexico & Japan
	PTZ-ACC-CORD-AUS	Mains power cord C13 AUS	Mains power cord C13 Type I • For Australia, New Zealand, China & Argentina



Additional accessories

CO₂ pressurization

CO₂ pressurization kits are used to ensure sealing integrity and to offset the pressure difference, allowing the HD30 to reach depths of 50m.



	Part number	Component	Description
	PTZ-ACC-CO2PUMP	CO ₂ pressurization pump	CO ₂ regulator pump for use with 16g CO ₂ cartridges • CO ₂ cartridges not included
	PTZ-ACC-CO2-3PCS	CO ₂ Gas Cartridge 16g 3Pcs	Three CO ₂ cartridges for camera head pressurization • Each cartridge contains 16g

Case



	PTZ-ACC-CASE	Ca-Zoom HD System case	Ca-Zoom HD System case • Rugged hard shell case with foam cutouts for Ca-Zoom HD Pendant in the lid • Foam insert for PTZ HD30 and TZ1 HD cameras • Foam cutouts in main compartment for Ca-Zoom HD cam controller, power supply, PTZHD30 10m cable and TZ1 HD 30m cable • Outer dimension 690 x 380 x 358 mm • Small box for tools and spares
	PTZ-ACC-BKPK	Ca-Zoom HD Backpack	Ca-Zoom HD Backpack • Rugged hard shell with foam cutouts • Cutouts for Pendant, Controller, Power supply • Cutout for either PTZHD30 or TZ1 camera

Mounting

Pole Mounts

	Part number	Component	Description
	PTZ-ACC-POLEMNT	PTZ HD30 - pole mount for V4010 pole	Stainless steel PTZ HD30 camera mounting to connect carbon fiber pole (V4010-1000/V4010-1003), including mounting screws.
	TZI-ACC-POLEMNT	TZI HD - pole mount for V4010 pole	Stainless steel TZI HD camera mounting to connect carbon fiber pole (V4010-1000/V4010-1003), including mounting screws.

Poles

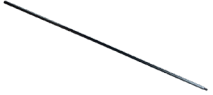
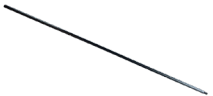
	V4010-1036	Tripod ball joint w/6' pole (x3)	Swivel tripod with spherical bushing, three 6' (1.8M) carbon fiber poles and mounting hardware. Provides added benefit of pivoting the PTZ system in a manway access. (Includes PTZ pole hardware package part number 4010-3005, which is a bracket and screws).
	V4010-1037	Tripod w/ball joint - manway	Swivel tripod with spherical bushing Provides added stability and the benefit of pivoting the PTZ system in a manway access up to 36" dia. Applications: Up vertical, Down vertical, Horizontal, and Manway. (Requires PTZ poles (aluminum or carbon fiber poles) and PT V4010-1037Z hardware package part number 4010-3005).
	V4010-1000	Carbon fiber pole - 6' section	Carbon fiber pole, 6' (quantity 1 ea) ... (same as swivel manway poles, can be used as NON-TELESCOPING poles for V4010-1010 OR V4010-1030)
	V4010-1003	Carbon fiber pole - 3' section	Carbon fiber pole, 3' (quantity 1 ea) ... (same as swivel manway poles, can be used as NON-TELESCOPING poles for V4010-1010 OR V4010-1030).

Regional offices

Asia

China

No. 8 Xi hu Road,
Wu jin high-tech zone Changzhou,
Jiang Su 213164 China
custsvchina@bakerhughes.com
wgcustcare.cn@bakerhughes.com
+86 800 915 9966 (toll-free)
+86 (0) 21-3877 7888

Japan

4-16-13 Tsukishima Chuo-ku,
Tokyo 104-0052,
Japan
custcare.jp@bakerhughes.com
wgcustcare.jp@bakerhughes.com
service.itsv_jp@bakerhughes.com
+81 442 67 7067

Singapore

10 Lok Yang Way
Singapore 628631
custcare.au@bakerhughes.com
custcaremckorea@bakerhughes.com
custcaresea@bakerhughes.com

Middle East

Mussafah Industrial Area,
Sector : MW-4,Plot: 13A1-A, Str 16th,
Abu Dhabi- United Arab Emirates.
PO Box 47513
custcare.inspectionmea@bakerhughes.com
waygate.me@bakerhughes.com
+971 48211794

India

A/78-1, Chakan MIDC Phase II,
Village Vasuli, Tal-Khed,
Pune 410501,
Maharashtra, India
cc.it.india@bakerhughes.com
waygate.india@bakerhughes.com
+91 2261595872

Americas

United States

721 Visions Drive
Skanateles, NY 13152
customer.care@bakerhughes.com
waygate.usa@bakerhughes.com
+1 866 243 2638

Brazil

Rod. Jorn. Francisco Aguirre
(SP 101-Km 3,8)
Campinas - SP - Brasil
CEP 13064-654
cc.inspection.brasil@bakerhughes.com
waygate.latam@bakerhughes.com
+55 11 3612-0710

Europe

Germany

Robert Bosch Strasse 3
50354 Huerth
cc.rvi.de@bakerhughes.com
+49 2233 601102

Waygate Technologies, a Baker Hughes Business has sales and service offices all over the world. Below are some of our locations.

Visit www.waygate-tech.com

- Berchem, Belgium
- Alzenau, Germany
- Burford, United Kingdom
- Moscow, Russia
- Bucharest, Romania
- Prague, Czech Republic
- Stockholm, Sweden
- Milan, Italy
- East Perth, Australia
- Singapore
- Dubai, UAE
- Buenos Aires, Argentina
- Mexico City, Mexico
- Airdrie, Alberta, Canada
- Toronto, Ontario, Canada
- Montreal, Quebec, Canada

Baker Hughes 