

# Masoneilan™ Lo-dB™ Cartridges and Expansion Plates



# Table of Contents

<b>Introduction</b> .....	<b>3</b>
<b>Application</b> .....	<b>3</b>
<b>Lo-dB Cartridges</b> .....	<b>4</b>
Principle of Operation .....	4
Installation .....	4
Construction.....	5
General Data.....	6
Materials .....	6
Flow Coefficient.....	6
Dimensions.....	6
Specifications .....	7
Capacity Limitations.....	8
<b>Lo-dB Expansion Plates</b> .....	<b>9</b>
Principle of Operation .....	9
Installation .....	9
Flow Coefficient.....	9
Construction.....	10
General Data.....	10
Materials .....	10
Dimensions.....	11
Specifications .....	11

# Introduction

In the fluid process industry, to protect both the environment and the safety of plant personnel, users and industry regulators are more frequently demanding a sound pressure level (SL) of 85–90 dBA as measured one meter from the noise source. To meet this condition, particularly when the operating pressure drop exceeds the critical limit, many valve manufacturers recommend adding a downstream device to create back pressure on the valve and add an additional stage of pressure reduction.

There are two types of industry devices that are used to accomplish this condition. One option is a silencer, which provides a minimal pressure drop while adding shielding features to dampen noise. Due to their required expanded outlet to limit velocity, silencers can be quite heavy and cumbersome, and thus costly to purchase and install.

A second and more cost effective option is an expansion plate. Expansion plates are line-size devices that are matched to the expanded pipe downstream of the valve. The Masoneilan Lo-dB cartridges and Lo-dB plates by

Baker Hughes have evolved the traditional drilled hole expansion plate into an engineered device that optimizes acoustical efficiency relative to flow capacity.

Industry testing has been documented on other devices to create pressure drops in series with valves such as multi-turn piping, perforated plates, and metal sponges to name a few. For most of these devices, the noise reduction was generally insufficient and many of these devices were easily clogged by common pipeline debris. Masoneilan Lo-dB cartridge and Lo-dB plates solve these problems by providing an optimized flow passage to balance flow capacity with noise reduction. In addition, the normal foreign material that is encountered in process piping easily passes through these cartridges and plates.

It is recommended that Lo-dB cartridges and plates be installed with Lo-dB valves such as the Series 21000, 41005 or 77000, when the pressure ratio is higher than 4, or with standard valves when their sound pressure level requires a reduction of 20 dBA or more.

# Application

Masoneilan Lo-dB cartridges and plates are sized to sufficiently decrease the pressure drop across the valve until it becomes subcritical. Since this has little effect on the capacity of the valve, while greatly affecting the valve noise, it is normally unnecessary to increase the valve size. In general, proper application of a Lo-dB cartridge or plate requires a pressure ratio of at least 4 to 1. Lo-dB cartridges and plates are normally close coupled to the valve outlet in a closed system. Depending on the degree of noise reduction required, either single or multiple Lo-dB cartridges and plates are used with either standard or low noise valves. Sizing techniques for Lo-dB cartridges and plates are similar to valve sizing in regards to the use of  $C_v$  values.

Many open vent applications require large valve outlets and large downstream piping to eliminate the noise generated by high velocity fluid flow. These large systems can be expensive and may be unnecessary. By employing a Lo-dB cartridge or plate at the vent outlet, or at some downstream location, both the valve size and pipe size between the valve and cartridges or plates can be reduced, which can lead to significant savings in pipe costs. Lo-dB cartridges and plates used in combination with a vent silencer can lead to a significant cost reduction of the overall system.

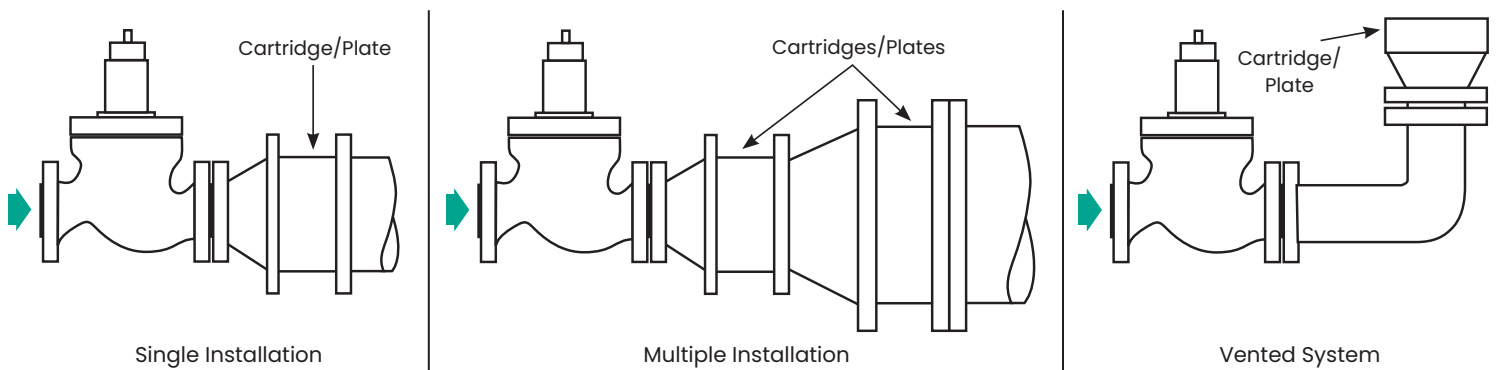

# Lo-dB Cartridges

## Principle of Operation

Masoneilan Lo-dB cartridge is a static device that produces a pressure drop in gas or vapor applications where a high pressure reduction is required. The cartridge employs a progressive pressure reduction through a tortuous path comprised of 16-stages. Through this staging process, the flow is also divided into a number of interconnected flow passages resulting in a microturbulent flow. Via these flow paths, both the mean

velocity as well as all discrete point velocities are controlled below a target threshold. As a result, Lo-dB cartridge acts as a high volume flow restriction while providing excellent core strength. Because this unique flow matrix is created with uniform components that are oriented into a composite assembly, the  $C_V$  is well-defined and reproducible.

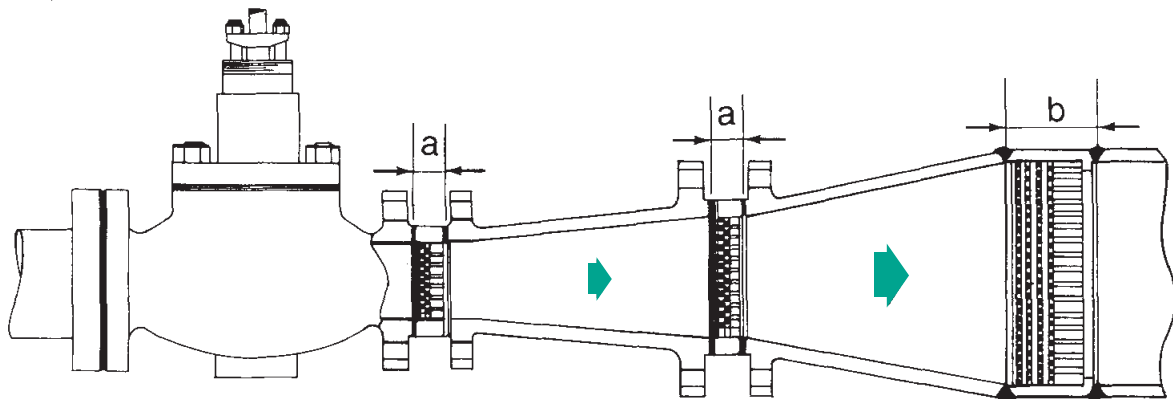

Control valve with three Lo-dB cartridges provides a cost effective method of noise control with gradual pipe expansion when dumping gas or steam into a low pressure system.

## Installation

Lo-dB cartridges are always mounted downstream of the control valve. For optimum noise reduction, Lo-dB cartridges should be mounted as close as possible to, and preferably directly adjacent to the valve outlet. Installation further downstream can result in piping cost savings, but can be less effective with regards to noise reduction.

The flow direction of the Lo-dB cartridge is indicated by an external flow arrow. Make certain that the Lo-dB cartridge is installed in the proper direction.

For flange mounted Lo-dB cartridges, the outside diameter of the cartridge housing matches the raised face diameter of the pipe flange.

When mounting between flanges, loosely connect the lower bolts to act as a cradle for the cartridge. After the cartridge is aligned, add the remaining bolts and tighten per normal torquing procedures.

Butt welded Lo-dB cartridges are installed by normal welding techniques according to the housing material and the mating piping.

Large Lo-dB cartridges are supplied with an eye bolt for maneuvering into position.

As in any high performance low noise device with small flow passages, the cleanliness of the system should be ensured before start-up.

# Lo-dB Cartridges

## Construction

### Housing

The exterior housing of the Lo-dB cartridge is constructed of carbon or stainless steel and machined to accept the internal components. At assembly, the internal components are compressed and held in place by welding the retainer ring to the housing. This construction applies to both flanged and butt weld constructions.

### Reducer Ring

Reduced capacity Lo-dB cartridges are designed with an additional 304 Stainless steel reducer ring inserted between the multi-stage element and the retainer ring.

### Retainer Ring

Both the multi-stage element and the support grate are held in place by the 304 Stainless steel welded retainer ring.

### Support Grate

The support grate is constructed of interlocked 304 Stainless steel bars and forms a trellis network whose diameter is equal to that of the multi-stage element. The support grate is shouldered against the housing to support the multi-stage element. Double support grates are available for increased pressure drops.

### Multi-Stage Element

The multi-stage element is constructed of a stack of resistance welded 304 Stainless steel grilles. Adjacent grilles are oriented in a controlled manner to maintain flow characteristics. The positioning of adjacent grilles with respect to each other provides the required noise reduction.

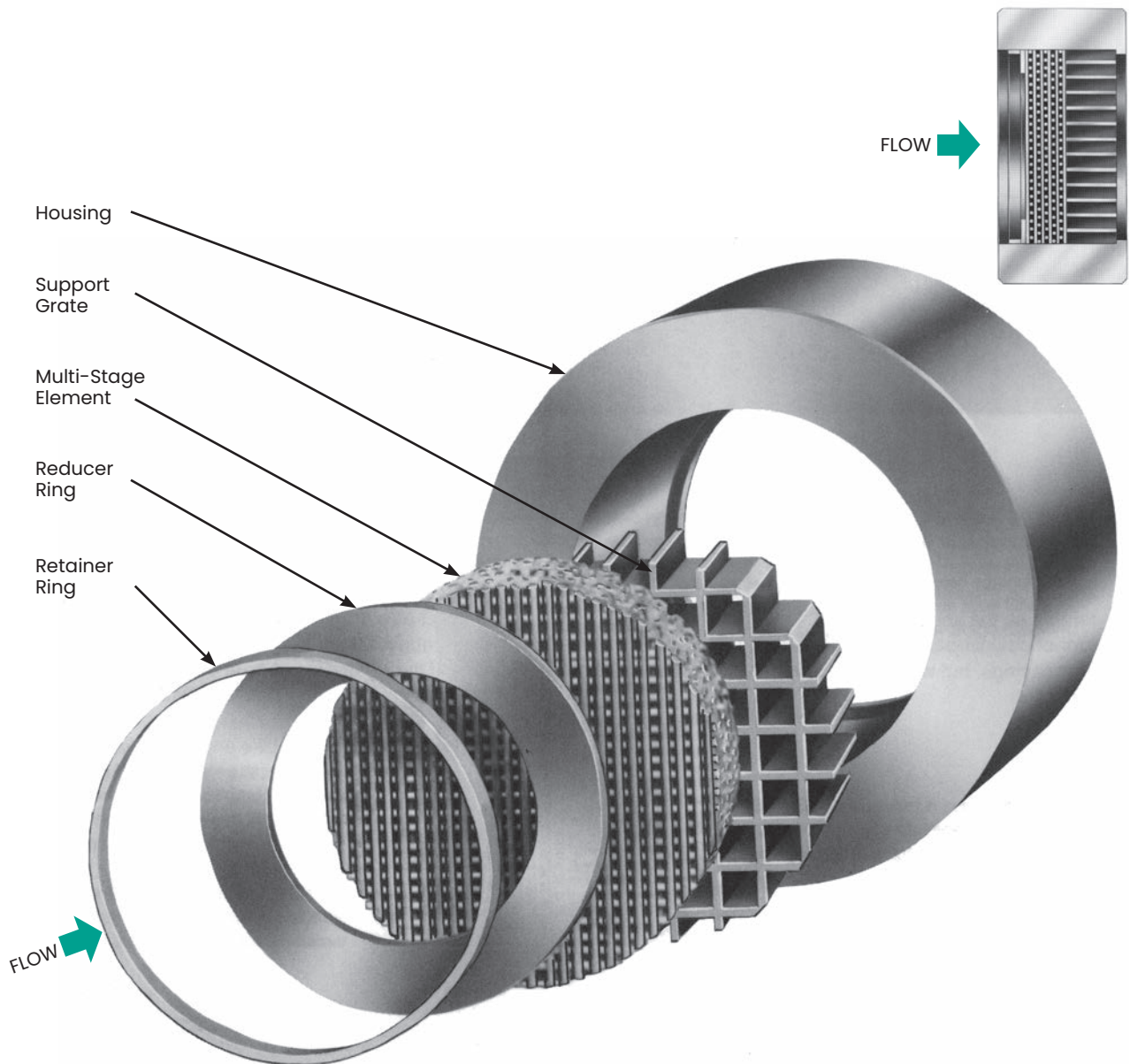

# Lo-dB Cartridges

## General Data

Flow Direction  
Uni-directional – per flow arrow

$C_V$  Range  
15 to 5900

Minimum Fluid Temperature  
–20°F (–29°C)

Maximum Fluid Temperature  
750°F (399°C)

Connections  
2" to 36" (DN50 to DN900):  
Wafer style mounting between flanges  
16" to 36" (DN400 to DN900):  
BWE connections available

## Materials

Multi-Stage Element  
304 stainless steel

Grate  
304 stainless steel

Retainer Ring  
304 stainless steel

Reducer Ring (for reduced capacity only)  
304 stainless steel

Housing (flange mounted)  
ASTM A515 Grade 70 carbon steel to 650°F (343°C)  
ASTM A240 Type 304 stainless steel to 750°F (399°C)

Housing (butt welded)  
ASTM A106 Grade B carbon steel to 650°F (343°C)  
ASTM A312 Type 304 stainless steel to 750°F (399°C)

## Flow Coefficient–Rated $C_V$ for Standard Lo-dB Cartridges<sup>(1)</sup>

$C_f = 0.99$

Cartridge Nominal Size													
Capacity	Inches	2	3	4	6	8	10	12	16	20	24	30	36
	DN	50	75	100	150	200	250	300	400	500	600	750	900
Full		21	45	82	195	330	535	780	1200	1900	2700	4200	5900
0.9		19	40	74	175	300	480	700	1080	1710	2430	3750	5300
0.8		17	36	66	155	265	430	625	960	1500	2200	3350	4700
0.7		15	31	55	135	230	375	545	840	1330	1890	2900	4150

1. Full flow coefficients are based on mating to Schedule 40 pipe. For capacity limitations imposed by use with heavier pipe schedules, see table on page 8.

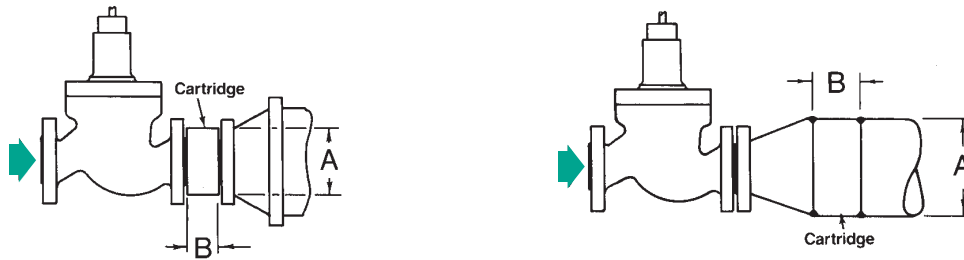

## Dimensions for Standard Lo-dB Cartridges

Nominal Size		Flange Mounted ASME Class 150 to 2500				Butt Welded Schedule 40 Pipe			
		A		B		A		B	
Inches	DN	Inches	mm	Inches	mm	Inches	mm	Inches	mm
2	50	3.6	91	4.0	102	-	-	-	-
3	75	5.0	127	4.0	102	-	-	-	-
4	100	6.2	157	4.0	102	-	-	-	-
6	150	8.5	216	4.0	102	-	-	-	-
8	200	10.7	272	5.0	127	-	-	-	-
10	250	12.8	325	5.0	127	-	-	-	-
12	300	15.0	381	5.0	127	-	-	-	-
16	400	18.5	470	7.2	183	16.0	406	8.6	218
20	500	23.0	584	7.2	183	20.0	508	8.6	218
24	600	27.2	691	7.2	183	24.0	610	8.6	218
30	750	33.7	856	7.2	183	30.0	762	8.6	218
36	900	40.2	1021	7.2	183	36.0	914	8.6	218

# Lo-dB Cartridges

## Specifications

### Pressure Drop vs. Temperature <sup>(2) (3)</sup>

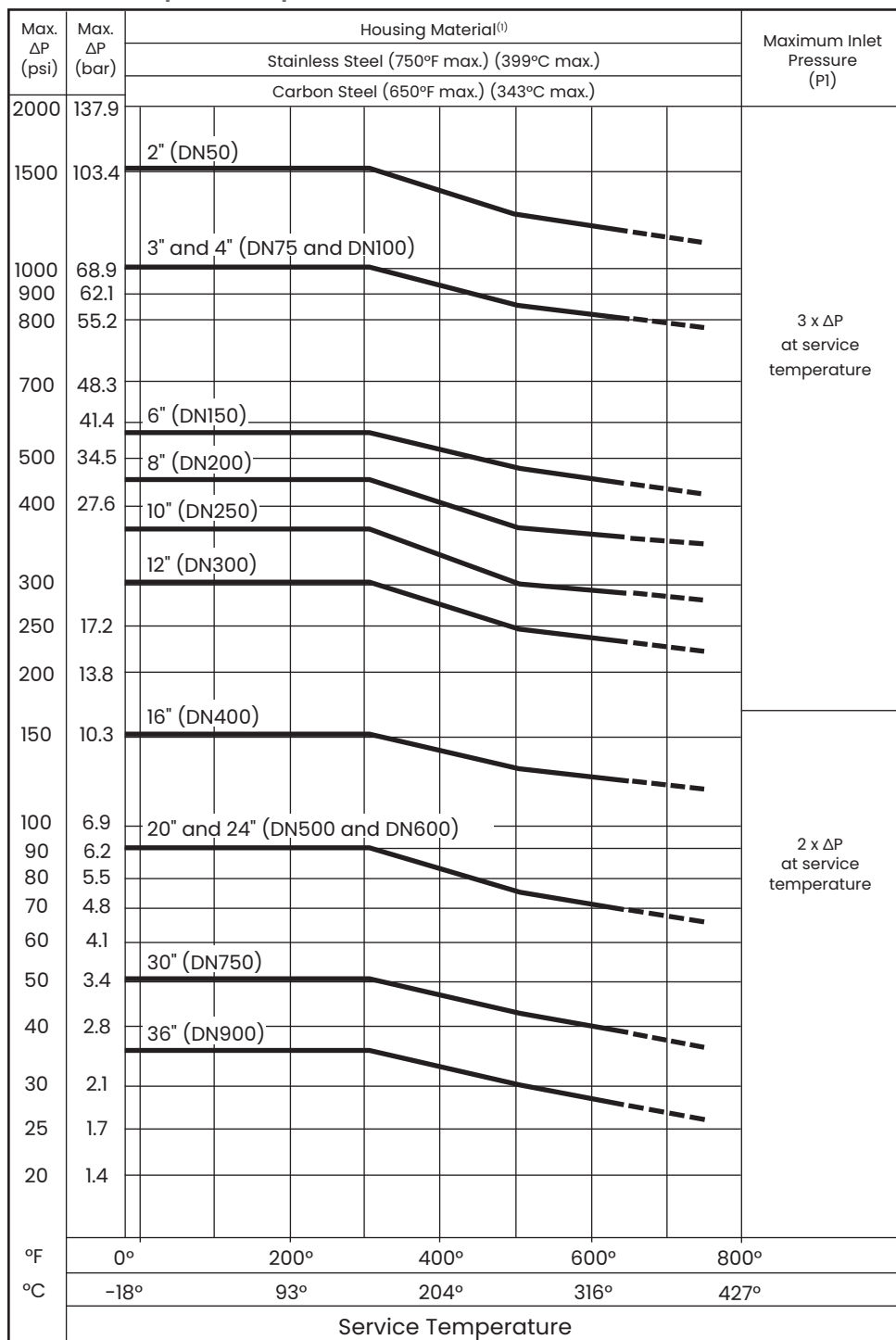

1. Consult Baker Hughes for other temperatures and materials.

2. Custom constructions are available to satisfy larger pressure drops. Consult Baker Hughes for application assistance.

3. For cyclic applications with temperatures exceeding 650°F (343°C) contact Baker Hughes.

# Lo-dB Cartridges

## Capacity Limitations for Standard Lo-dB Cartridges

Cartridge Nominal Size		Schedule	Maximum Capacity Factor	Maximum C <sub>v</sub>
Mating Pipe Size				
Inches	DN			
2	50	40/ST	Full	21
		80/XS	0.9	19
		160	0.7	15
		XXS	0.5	11
3	75	40/ST	Full	45
		80/XS	0.9	40
		160	0.7	31
		XXS	0.5	25
4	100	40/ST	Full	82
		80/XS	0.9	74
		160	0.7	55
		XXS	0.5	50
6	150	40/ST	Full	195
		80/XS	0.9	175
		160	0.7	135
8	200	40/ST	Full	330
		80/XS	0.9	300
10	250	40/ST	Full	535
		80/XS	0.9	480
12	300	40/ST	Full	780
		80	0.9	700

The above table lists capacity limits for 2" to 12" (DN50 to DN300) cartridges when installed in common heavy wall piping. For other cartridge sizes and pipe schedules, contact Baker Hughes. Refer to page 7 for maximum pressure and temperature limits. See below for typical examples.



# Lo-dB Expansion Plates

## Principle of Operation

Masonite Lo-dB expansion plates, designed for 1-stage and 2-stage construction, are provided to specifically absorb a large percentage of pressure drop that would otherwise be handled by the control valve. This can reduce the amount of noise generated by the system by up to 20 db. Lo-dB expansion plates are mounted downstream of a control valve to raise the valve outlet pressure while maintaining a choked flow condition across the valve. This serves to reduce the downstream velocity and ensures that the noise generated in the downstream pipe does not exceed the valve noise. As with Lo-dB cartridges, Lo-dB plates do not necessitate use of larger control valves. These devices reduce noise and related vibration instead of muffling noise like conventional silencers.

In general, Lo-dB plates are more restrictive than Lo-dB cartridges within the same nominal size. Thus, Lo-dB plates provide more back pressure to the adjacent valve and are more effective at reducing noise.

## Installation

Lo-dB expansion plates are always mounted downstream of the control valve. The distance between the valve and the plate, or between adjacent plates in series, is not critical. A plate can be mounted in any convenient location in the downstream piping. In most cases, valves and reducers having heavier walls than the adjoining piping provide additional noise attenuation. The plate itself acts

as a barrier to the sound waves produced upstream. If the Lo-dB plate is mounted directly against the valve outlet flange, or if the valve and plate are only separated by a reducer, an additional net reduction of 6 dB in valve sound pressure level is obtained.

The flow direction of the Lo-dB plate is indicated by an external flow arrow. Make certain that the plate is installed in the proper direction.

Lo-dB plates from size 2" to 24" (DN50 to DN600) are bolted between conventional ASME Class pipe flanges on the downstream side of the control valve, normally in conjunction with pipe expanders. The outside diameter of the Lo-dB plate housing matches the raised face diameter of the pipe flange. When mounting between flanges, loosely connect the lower bolts to act as a cradle for the plate. After the plate is aligned, add the remaining bolts and tighten per normal torquing procedures.

Larger Lo-dB plates, from size 16" to 36" (DN400 to DN900) are designed with butt weld connections. Butt welded Lo-dB plates are installed by normal welding techniques according to the housing material and the mating piping.

Large Lo-dB plates are supplied with an eye bolt for maneuvering into position.

As in any high performance low noise device with small flow passages, the cleanliness of the system should be ensured before start-up.

## Flow Coefficient-Rated $C_v$ for Standard and Reduced Lo-dB Plates<sup>(1)</sup>

$C_f=0.95$

1-Stage Lo-dB Expansion Plates																
Capacity	Inches	2	3	4	6	8	10	12	14	16	18	20	24	26	30	36
	DN	50	75	100	150	200	250	300	350	400	450	500	600	650	750	900
Full		25	63	110	270	490	770	1100	1350	1800	2300	2900	4250	5000	6950	10000
0.9		23	59	100	245	440	690	1000	1200	1600	2100	2600	3800	4500	6250	9000
0.8		21	52	90	210	390	610	895	1050	1450	1850	2300	3400	4000	5550	8000
0.7		19	45	82	180	330	520	760	945	1200	1550	1900	2950	3500	4850	7000
0.6		17	39	70	150	270	450	660	810	900	1300	1600	2550	3000	4150	6000
0.5		15	33	55	135	230	380	530	675	800	1100	1450	2100	2500	3450	5000

1. Use  $C_v$  in conjunction with the sizing equations. See Baker Hughes Noise Control Manual.

2-Stage Lo-dB Expansion Plates																
Capacity	Inches	2	3	4	6	8	10	12	14	16	18	20	24	26	30	36
	DN	50	75	100	150	200	250	300	350	400	450	500	600	650	750	900
Full		-	20	40	80	155	230	310	-	460	620	700	920	1240	1840	2480
0.9		-	17.5	35	70	135	210	270	-	385	540	630	770	1080	1540	2160
0.8		-	15	29	58	115	175	230	-	-	-	-	-	-	-	-
0.7		-	12	24	48	95	145	190	-	-	-	-	-	-	-	-

# Lo-dB Expansion Plates

Masoneilan Lo-dB expansion plates employ either a single stage, or 2 stage flow path, which limits velocity variation from stage to stage and creates thorough mixing of the fluid. These features contribute to the high noise reduction capabilities of the Lo-dB plates.

The Lo-dB plates are constructed of 304 Stainless steel welded to a carbon steel housing for use up to 650°F (343°C). For higher temperatures, a housing constructed of 304 Stainless steel is used. Consult the Baker Hughes Engineering Department if the  $\Delta P$  versus temperature ratings on page 11 will be exceeded.

## Housing

The exterior housing of the Lo-dB plate is constructed of carbon or stainless steel and machined to accept the plates. At assembly, the plates are compressed and held in place during full circumferential welding.

## Drilled Hole Plates

The first and second stage plates are constructed of 304 stainless steel. The arrangement of the drilled hole configuration is designed to provide optimum 2-stage pressure reduction.

## Plate Spacer

The plate spacer is employed to provide alignment during fabrication and structural support in service.

## General Data

### Flow Direction

Uni-directional – per flow arrow

### C<sub>v</sub> Range

12 to 10,000

### Minimum Fluid Temperature

-20°F (-29°C)

### Maximum Fluid Temperature

750°F (399°C)

### Pressure Rating

2" – 12": ANSI 150-2500

12" – 24": ANSI 150-1500

26" – 36": ANSI 150-600

### Connections

2" to 24" (DN50 to DN600)

Wafer style mounting between flanges

16" to 36" (DN400 to DN900)

BWE connections available

1. Refer to  $\Delta P$  versus Temperature graph page 11 for maximum static ratings. Other standard pipe schedules can be accommodated. Consult Baker Hughes.

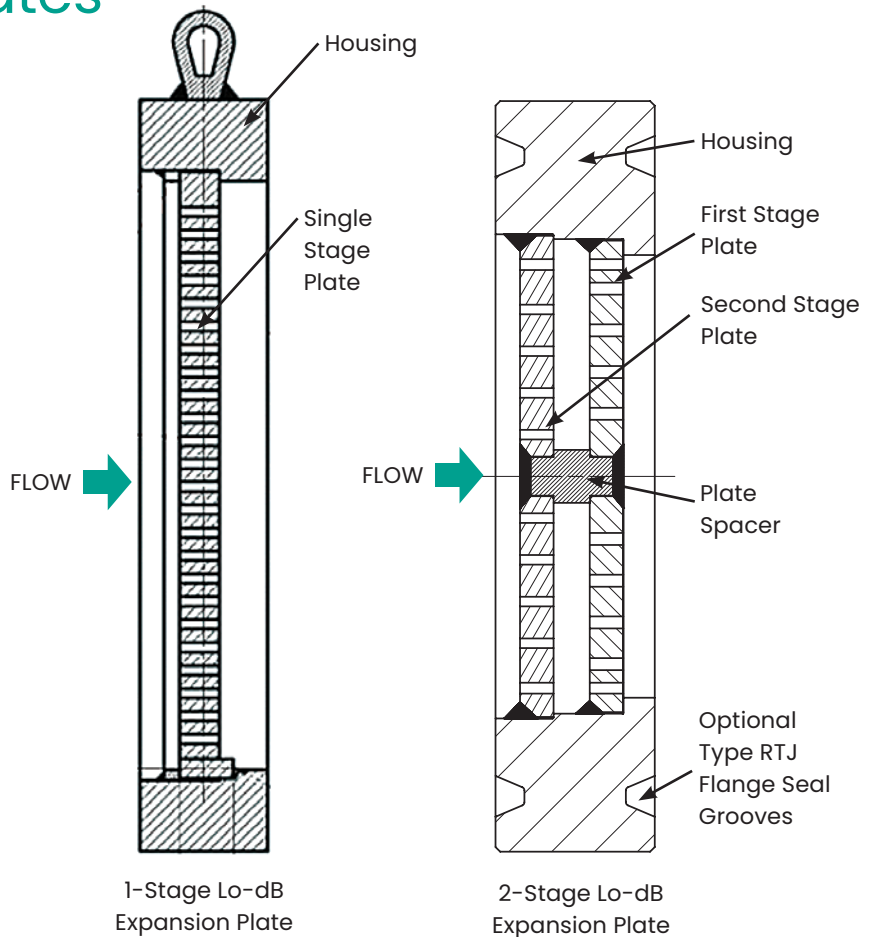

## Materials

### Drill Hole Plates

304 stainless steel

### Housing (flange mounted)

ASTM A515 Gr 70 carbon steel to 650°F (343°C)

ASTM A240 Type 304 stainless steel to 750°F (399°C)

### Housing (butt welded)

ASTM A106 Gr B carbon steel to 650°F (343°C)

ASTM A312 Type 304 stainless steel to 750°F (399°C)

# Lo-dB Expansion Plates

## Specifications

### Pressure Drop vs. Temperature<sup>(2)</sup>

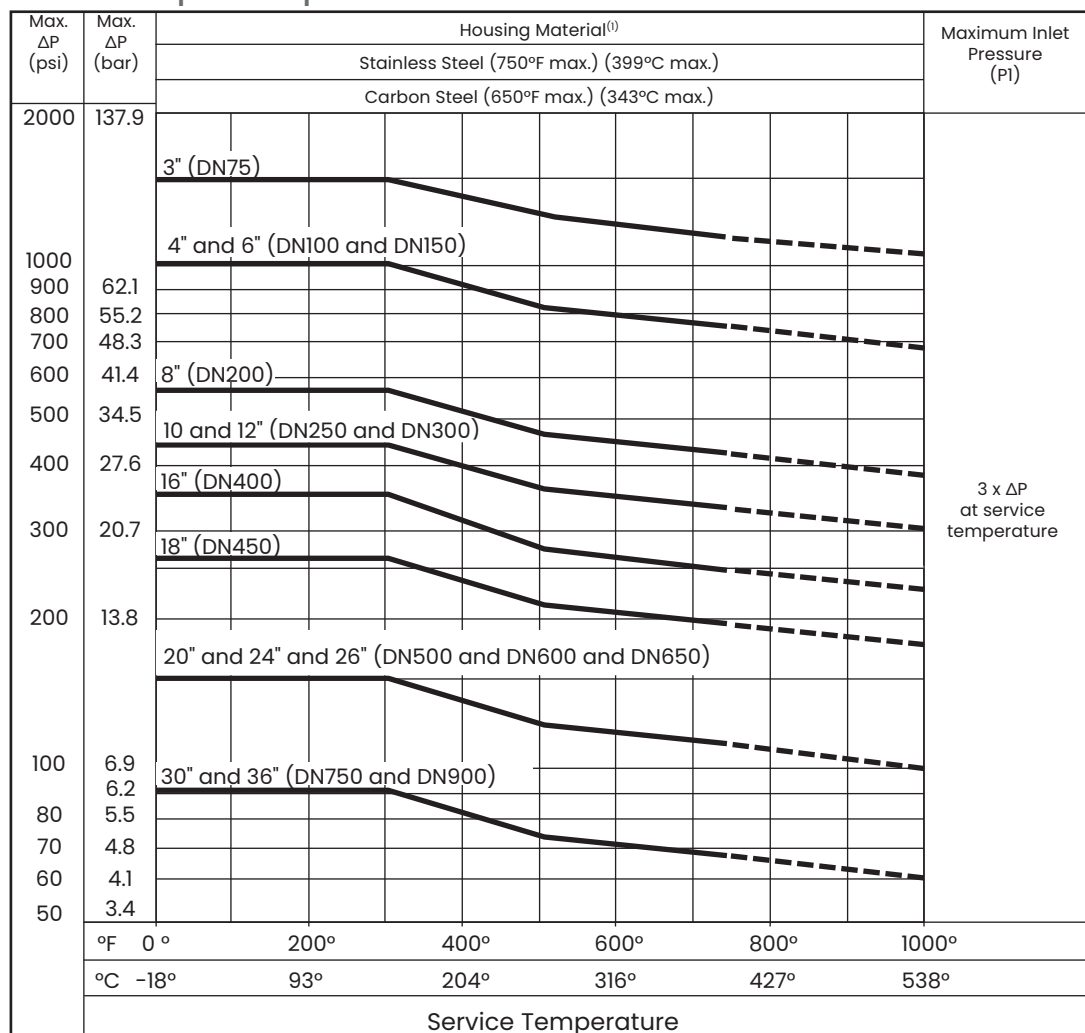

1. Consult Baker Hughes for other temperatures and materials.  
 2. Custom constructions are available to satisfy larger pressure drops. Consult Baker Hughes for application assistance.

Plate Nominal Size		Flange Mounted ASME 150 to 2500		Butt Welded Schedule 40 Pipe	
		A		B	
Inches	DN	Inches	mm	Inches	mm
3	75	1.2	30	-	-
4	100	1.2	30	-	-
6	150	1.5	38	-	-
8	200	1.5	38	-	-
10	250	2.0	51	-	-
12	300	2.0	51	-	-
16	400	-	-	6.0	152
18	450	-	-	6.0	152
20	500	-	-	6.0	152
24	600	-	-	6.0	152
26	650	-	-	6.0	152
30	750	-	-	6.0	152
36	450	-	-	6.0	152

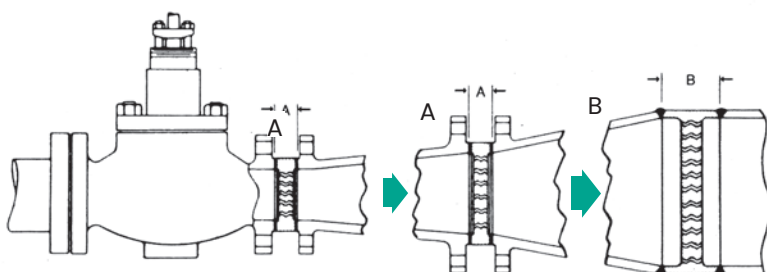

# Find the nearest local Channel Partner in your area:

[valves.bakerhughes.com/contact-us](https://valves.bakerhughes.com/contact-us)

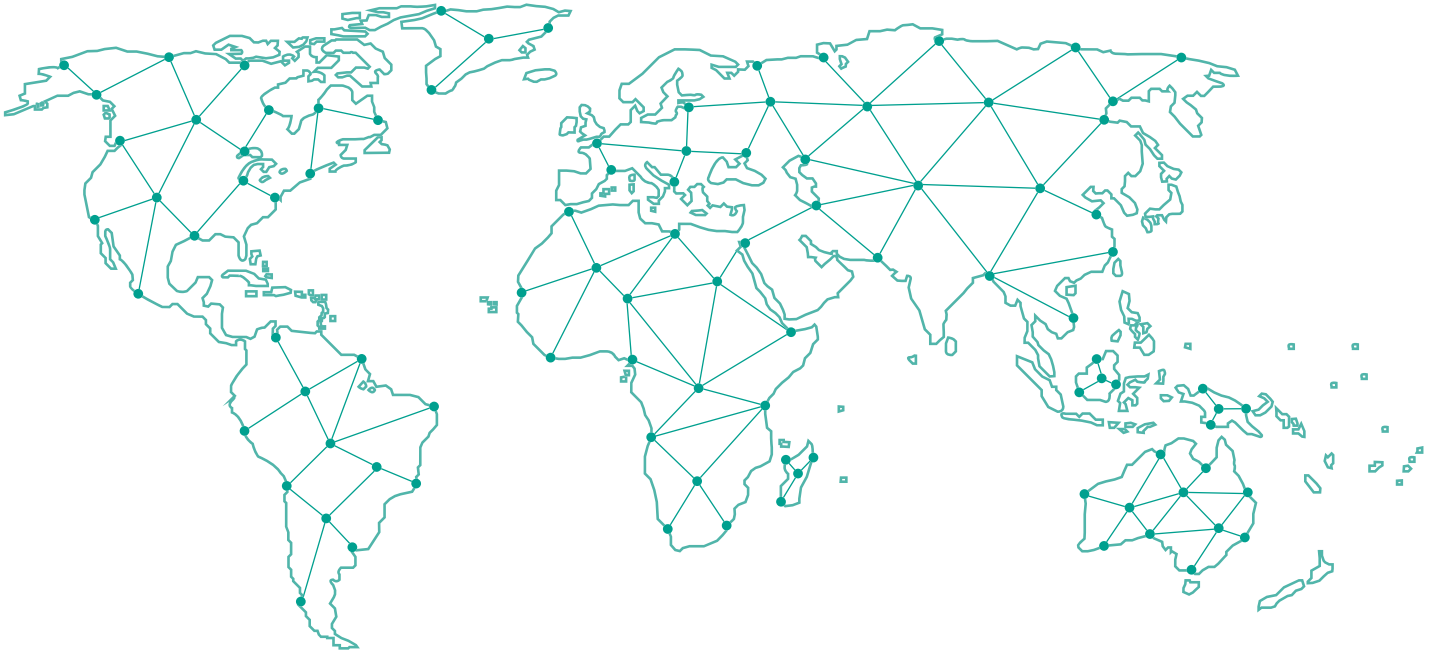

## Tech Field Support and Warranty:

Phone: +1-866-827-5378

[valvesupport@bakerhughes.com](mailto:valvesupport@bakerhughes.com)

[valves.bakerhughes.com](https://valves.bakerhughes.com)

Copyright 2024 Baker Hughes Company. All rights reserved. Baker Hughes provides this information on an "as is" basis for general information purposes. Baker Hughes does not make any representation as to the accuracy or completeness of the information and makes no warranties of any kind, specific, implied or oral, to the fullest extent permissible by law, including those of merchantability and fitness for a particular purpose or use. Baker Hughes hereby disclaims any and all liability for any direct, indirect, consequential or special damages, claims for lost profits, or third party claims arising from the use of the information, whether a claim is asserted in contract, tort, or otherwise. Baker Hughes reserves the right to make changes in specifications and features shown herein, or discontinue the product described at any time without notice or obligation. Contact your Baker Hughes representative for the most current information. The Baker Hughes logo, Masoneilan and Lo-dB are trademarks of Baker Hughes Company. Other company names and product names used in this document are the registered trademarks or trademarks of their respective owners.

**Baker Hughes** 

[bakerhughes.com](https://bakerhughes.com)