



Floating Production Storage and Offloading (FPSO)

Best in class valve technology and superior application engineering

Baker Hughes FPSO Control and Safety Valve Solutions

The FPSO market is dynamic and challenging across all applications. Selecting the right control and safety relief valve technology is critical towards your process optimization.



Optimize Service



Improve Reliability



Increase Efficiency



Reduce Emissions

For the extreme environments of FPSO, choose the optimal control and safety relief valve solutions for all separation, compression, dehydration, and auxiliary applications.

Optimize Service

In remote locations where unplanned service is not an option, harness the power of Valve Lifecycle Management (VLM) condition-based monitoring to proactively predict and prevent failures.

Improve Reliability

Mitigate concerns of corrosion and downtime of external equipment operating in harsh marine conditions with the 316SS housing and non-contact sensing capabilities of the SVI™ Digital Valve Positioner.

Increase Efficiency

Increase production output with the highest efficiency over-pressure protection equipment available, our high pressure pilot-operated relief and control valves.

Reduce Emissions

Make your FPSO best in class with Low-E valve solutions offering the tightest available standards against total emissions, meeting ISO-15484 CCI Class B or better, regardless of system pressure.





Floating Production Storage and Offloading (FPSO)'s have varying capacities, but all installations face the same challenges when extracting hydrocarbon resources. In addition to the nature of remote offshore installations, high pressure wells with sand and caustic chemicals within the flow stream can be extremely corrosive, erosive, and destructive to process equipment. Selecting the right process control and safety relief equipment is critical to addressing difficult FPSO applications and preventing against premature equipment damage from vibration and other application induced challenges.

FPSO Process Flow Diagram

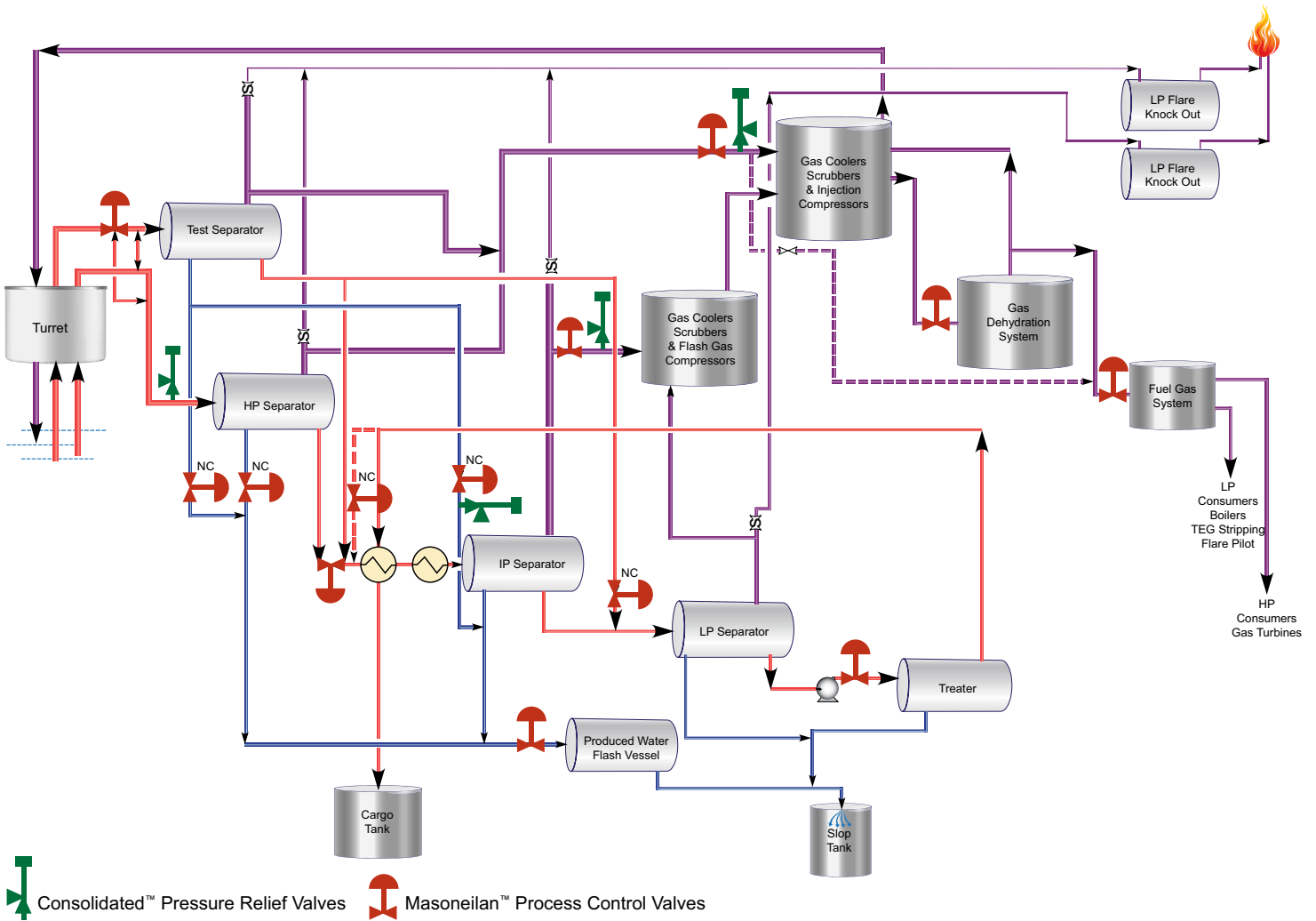

High-Pressure Gas-Injection Compressors



Intermediate-Pressure Gas-Lift Compressors



Crude Oil Treatment, Desalting

Dehydration

An important function in FPSO processing is gas dehydration, where water and hydrocarbon liquids are fully removed from the gas. The gas is then used for fuel gas or recompressed and injected back into the well. Valves used for dehydration must meet specific criteria, and careful consideration should be given to several factors.

- Percent of entrained water in the amine
- Cavitation potential of the water
- Downstream piping configuration
- Multiphase overpressure protection relief scenarios

Featured Solutions

High Pressure Letdown

Masoneilan™ LincolnLog™

The leading cause of poor control valve performance and premature failure in high pressure liquid letdown service is cavitation. The LincolnLog anti-cavitation control valves can be custom engineered with as many as ten stages of pressure reduction for applications with extreme pressure drops in excess of 8000 psi (550 Bar).



Multimedia Certified Pressure Relief

Consolidated™ Spring-Loaded and Pilot Operated Safety Relief Valves

Multimedia certified safety pressure relief valves rated for up to three media (air/gas, liquid, and steam), are the ideal solution for flashing and phase change process conditions. The 1900 DM, 2900 TM, and 3900 TM are the first relief valves introduced to the market with multimedia certification, designed specifically for these challenging applications.

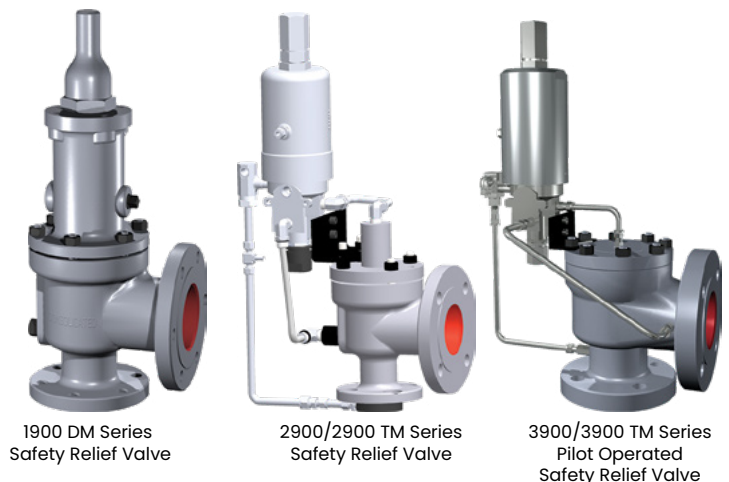

Compression

Gas compression is a critical part of preparing extracted gas either for onshore use, powering the vessel, or reinjection into the well. Once separated from the combined liquid hydrocarbon and water media, the gas is then processed through the compression unit. This involves multiple process stages, including high pressure and low pressure compression depending upon its intended use. Typical valve challenges around compressor stations include: high noise levels, fast stroking speeds to prevent surge, control accuracy, easy maintenance, high pressure overpressure protection for gas injection systems.

Compressor Anti-Surge Systems

The Masoneilan compressor anti-surge package is uniquely suited for FPSO compressor demands. The custom package can manage fluid velocity with as many as 40 stages of pressure reduction and can fully stroke in less than 0.5 seconds.

Featured Solutions

High Pressure Gas Injection

Consolidated 1900 DM/3900 TM (Block Body) Forged API 10K/15K Safety Relief Valves

Consolidated high pressure API 10K/15K SRVs combine the technology of dual media certification as defined by API 520 Part 1 - 10th Edition and ASME B & PVC Code Case 2787 with the robust forged block body design to handle FPSO high pressure compression and auxiliary system applications. These block body designs are the ideal solution for high pressure liquid/gas application, two-phase liquid and gas, flashing, or multiple relief case scenarios.

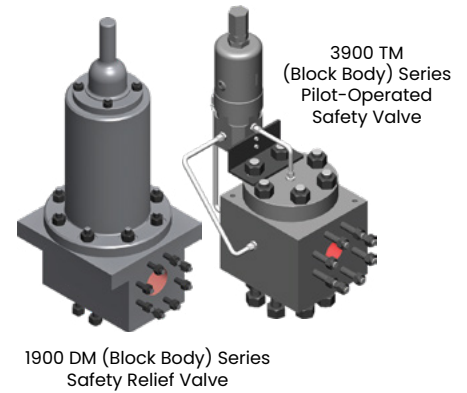

Masoneilan API 6A 10K/15K High Pressure Control Valves

Masoneilan offers a portfolio of high pressure API 10k/15k control valves, including the 21000 and 41005 Series globe valves, and 78400/18400 Series LincolnLog anti-cavitation high pressure degassing valves. Valve bodies and trims are configured to address flow, pressure and velocity control across the full range of FPSO applications. These valves offer minimum footprint with compact forged bodies, and are available with flanged or hub end connections. Body to bonnet interfaces utilize patented Baker Hughes' seal technology where meeting high pressure and fugitive emissions standards are critical.



21000 API 6A Control Valve Series



41005 API 6A Control Valve Series



78400/18400 Series LincolnLog Anti-Cavitation Control Valve

Low-E Packing Solutions

Masoneilan offers low emission packing solutions, in compliance with the latest ISO and EPA regulatory specifications for standard and API 6A control valve offerings.

Note: The number of packing rings may vary depending on valve size and model.

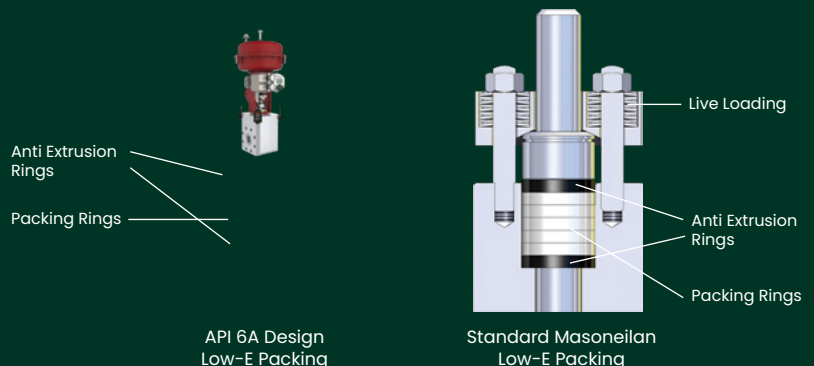

Auxiliary Processes

The auxiliary process function serves to treat extracted water from the well. From surge flow control to pump recirculation and chemical injection, the auxiliary steps are essential for keeping operations running smoothly.

The main challenges that auxiliary valves must address include:

- Cavitation and erosion from high pressure drops
- Dirty conditions with sand in the water
- Corrosive service conditions depending upon the water type
- Low pressure drop at higher flows requiring higher C_v
- Vibration from high velocity fluid flow
- Systems running at high operating pressure
- High pressure overpressure protection for chemical and water injection systems

Featured Solutions

Water Reinjection Valve

Masoneilan 78400/18400 Series LincolnLog, High Pressure Anticavitation Valve

The LincolnLog comes in both globe and angle style featuring multistage, high pressure energy management trim to prevent cavitation and potential wear to the valve within the water reinjection process.



78400/18400 Series LincolnLog
High Pressure, Anticavitation Valve

Zero Emissions, High Pressure Pilot Valves

Consolidated 2900/2900 TM and 3900/3900 TM Series "True Zero Leakage" Pilot Valves

The 2900/2900 TM Gen II and 3900/3900 TM Series are the premiere solutions for reducing emissions in high operating pressure applications.

Consolidated pilot operated designs offer industry leading performance with both main valve and pilot seat tightness up to 98% of set pressure.



2900/2900 TM Series Gen II
Pilot-Operated Safety Valve

3900/3900 TM Series
Pilot-Operated Safety Valve

Separation

Before an FPSO can process the oil and gas products, it first must separate the multimedial flow into gas, liquid hydrocarbons, and water. This includes several stages of processing to remove impurities before its transported for full onshore processing.

Typical valve challenges for separation processes include:

- High noise levels from pressure letdown
- Dirty service conditions with gas, hydrocarbon liquid, water, and sand
- Corrosive chemicals present such as H_2S , CO_2 , or chlorides
- High flow pressure drop causing cavitation and erosion
- Multiphase overpressure protection relief scenarios

Featured Solutions

Gas Wellhead Control

Masoneilan 77000 Series Axial Flow, Multistage Trim Valve

The 77000 Series valve was developed for extremely high pressure applications that require multiple pressure letdown stages and an expanding downstream area in the trim to accommodate compressible flow expansion. By directing the flow through a series of expanding stages, the trim design helps reduce the pressure of dirty gases and flashing in multiphase liquids.

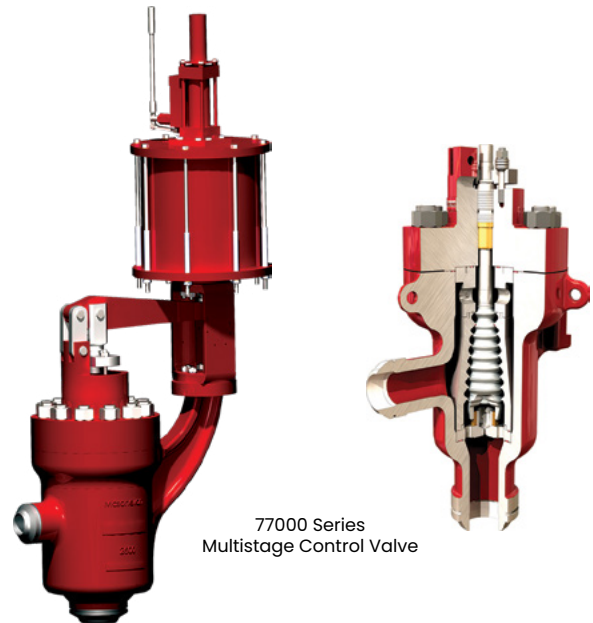

General Service PRV's

Consolidated 1900 Dual Media (DM) Series Dual Certified Spring-Loaded Safety Relief Valves

The 1900 DM is the industry's first first dual certified spring-operated PRV for gas, liquid and multiphase applications. Specifying a certified dual media valve is the best and only way to protect against undersizing a pressure relief device in multiphase flow applications.

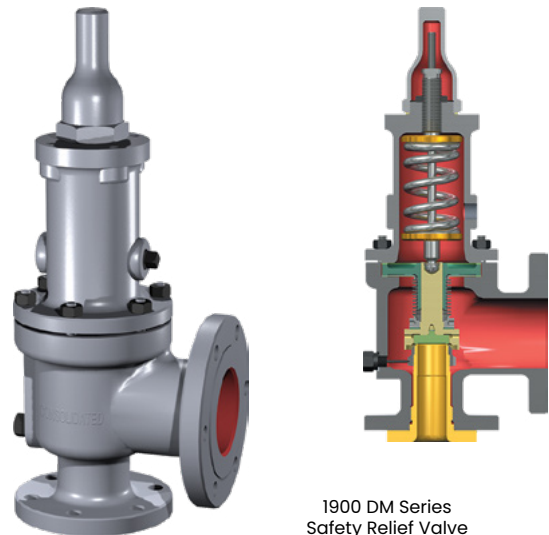

Consolidated Solutions for FPSO Challenges

Consolidated Pressure Relief Valves

Comprehensive overpressure protection solutions for ensuring safety, emissions reduction, and operating efficiency in FPSO applications.



1900 DM Series
Safety Relief Valve

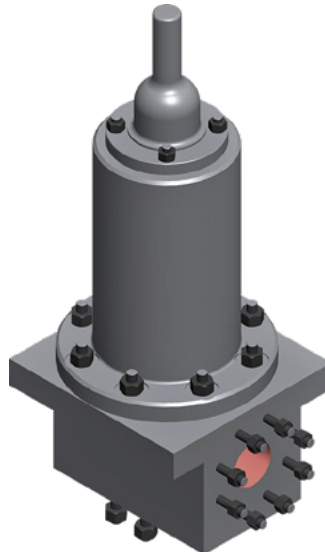

1900 DM (Block Body) Series
Safety Relief Valve



19000 Series
Safety Relief Valve

1900 DM Series

The patented innovation of the Dual Media trim design makes it the first and only spring-loaded safety relief valve in the industry that is “dual certified”, as defined by API Standard 520 Part 1 – Sizing and Selection, 10th Edition. The 1900 DM trim is engineered to perform on both liquid and/or gas media with exceptional blowdown performance and is dual certified to meet dual media (liquid and gas) capacity stamping per ASME B & PVC Code Case 2787. The 1900 DM trim is ideal for any liquid or gas application, two-phase liquid and gas, flashing or multiple relief case scenarios.

1900 DM (Block Body)

The 1900 DM Block Body combines the technology of the dual certified 1900 DM with the robust 1900 forged Block Body design to handle high pressure FPSO compression and auxiliary system applications. This valve is available with studded API 6A 10K and 15K connections for pressures up to 10,000 psig (689.5 barg).

19000 Series

The 19000 Series safety relief valve offers a reliable, light and compact design for low installation costs and total cost of ownership. With sizes as small as ½”, this valve is ideal for thermal relief and other low capacity relief scenarios. The 19000 Series meets and exceeds API 527 seat tightness performance, an exceptionally short fixed blowdown, and a versatile design with screwed, flanged, or socket weld connections available.



2900/2900 TM Series Gen II
Pilot-Operated Safety Valve



3900/3900 TM Series
Pilot-Operated Safety Valve

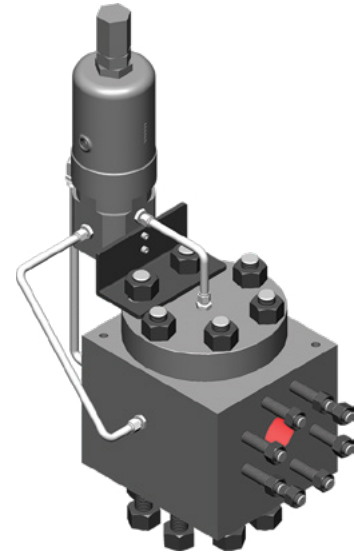

3900 TM (Block Body) Series
Pilot-Operated Safety Valve

2900/2900 TM Series POS RV

The 2900 TM Series is the first full nozzle pilot-operated safety relief valve engineered to perform with liquid, air/gas, and steam media and is multimedia certified to meet multiple media capacity stamping per ASME B & PVC Code Case 2787. Its patented full nozzle integral sense design allows for easy maintenance, and allows for simple conversions from spring-loaded to pilot-operated configurations. This valve uses the same pilot valve technology as the 3900/3900 TM Series including the 'True Zero Leakage' modulating pilot, providing a modernized overpressure protection solution for reducing carbon footprint and emissions.

3900/3900 TM Series POS RV

The 3900/3900 TM Series pilot-operated safety relief valves feature a semi-nozzle main valve design that meets API 526 center-to-face dimensional requirements. The 3900 TM Series is one of the first pilot-operated safety relief valves engineered to perform with liquid, air/gas, and steam media and is multimedia certified to meet multiple media capacity stamping per ASME B & PVC Code Case 2787. This valve features the 'True Zero Leakage' modulating pilot which helps to reduce emissions and improve operating efficiency by ensuring zero leakage from the entire valve all the way up to set pressure.

3900 TM (Block Body) POS RV

The 3900 TM Block Body combines the technology of the triple certified 3900 TM with the robust 3900 forged Block Body design to handle high pressure FPSO compression and auxiliary system applications. This valve is available with studded API 6A 10K and 15K connections for set pressures up to 13,500 psig (930.79 barg).

Masoneilan Solutions for FPSO Challenges

Masoneilan Process Control and Severe Service Valves

With a complete control valve portfolio of general service and severe service solutions, Masoneilan's globe and rotary valves offer the right solution and complexity for each application challenge.

Masoneilan provides a full line of accessories and components available in stainless steel to protect against the most harsh marine environments.



41005 Series Globe and Angle Cage-Guided Control Valve

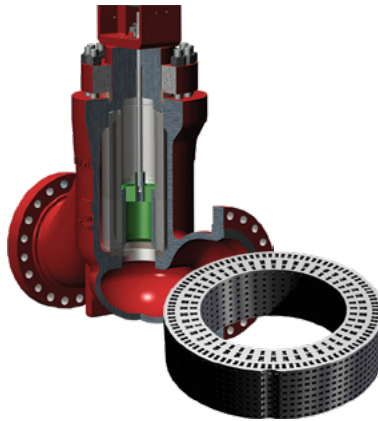

49000 Series Globe and Angle Control Valve V-LOG Energy Management Trim



35002 Series Camflex™, Eccentric Plug Rotary Valve

Compact Valve Design

Masoneilan valve assemblies are compact, low weight and have a low profile for easy handling and installation in space-limited offshore environments.

Materials of Construction

Our valves are available in a wide range of materials, including various grades of stainless steel, duplex stainless steel, and Titanium, Aluminum Bronze, and Hastelloy to promote valve life expectancy and functionality that may be cut short due to corrosion.

Energy Management Trims

Masoneilan severe service valves are available with specialized, high-energy management trims to meet staged pressure reduction needs found in separation, compression, and reinjection applications. Our trim options include Masoneilan Variable Resistance Trim (VRT™) that channels flow through a tortuous path and the V-LOG trim that redirects flow through a high resistance path.

Noise Attenuation

Masoneilan valves are available with *Lo-dB™*, and V-LOG technologies to help moderate high noise levels on FPSO vessels.

Actuators and Regulators

Masoneilan actuators and regulators help enable valve performance. Pneumatic, diaphragm, and piston actuators provide valve control. Regulators provide pressure reduction, back pressure, and differential pressure for a range of media from air and liquid to saturated and superheated steam.



12400 Series Digital Level Transmitter

SIL2-certified Digital Level Transmitters Controllers

Masoneilan instruments from Baker Hughes include level transmitters that operate according to fully proven buoyancy and torque-tube principles as well as electropneumatic transducers that offer flexibility in valve equipment communication. Also, Masoneilan pneumatic pressure boosters were developed for valve response and speed in high capacity applications.



Stainless Steel Fittings and Gauges

Stainless Steel Accessories

Stainless steel fittings and gauges are included as a part of every Masoneilan control valve package, for protection against corrosive marine and coastal environments.



SVI II ESD SIL3 Partial Stroke Test Device

Emergency Shutdown Valve Automation

The Masoneilan SVI II ESD Device from Baker Hughes is the SIL3-certified latest technology in emergency shutdown valve automation and in-service valve partial stroking. It is designed using the proven electronic and pneumatic technology from the SVI II AP valve positioner.



ValScope-Pro Diagnostics Software

Valve Asset Management Tools

Our full suite of valve asset management tools, including EVT PRO™, ValScope™, and ValvKeep™ asset management software help customers maintain efficient maintenance schedules, an important aspect of continuous at sea operations.



Masonellan SVI™ Digital Control Valve Positioner

Control and monitor your critical valve assets with the proven reliability of the SVI platform and new Valve Diagnostics.



SVI3 Digital Valve Positioner

The SVI is a user-friendly digital valve positioner for pneumatic control valves. Utilizing advanced control and diagnostic algorithms, along with field proven, non-contact position sensing technology, the SVI delivers accurate, responsive, and reliable positioning performance.



Continuous Health Monitoring

Improve efficiency and process uptime with continuously calculated diagnostics which monitor the health of the valve and process.

Plan turnarounds and prioritize repair events via data driven decisions utilizing one year of on-device diagnostic storage.

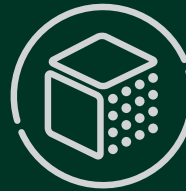

Simple, Modular Platform

Automated, self-calibration routines and universal mounting system provide effortless setup and commissioning across any linear or rotary control valve.



Performance & Reliability

Built upon 20+ years of field proven technologies with billions of operating hours, the SVI is trusted on the most critical applications.



Ready to Serve, Anywhere!

Designed with corrosion resistant materials, and universally certified to global hazardous area standards. Ready to serve with explosion proof rating for the presence of mining.

Global Support

We understand that you need a partner that understands the challenges you face and has the resources to support you from new products to maintenance cycles to changes in your process. Whether it is technical support, manufacturing, to maintenance planning we are here to support you.

Baker Hughes is committed to providing best in class products and service through manufacturing sites, Aftermarket centers and Channel Partners located throughout the world.



The Baker Hughes MARC and GTC Network consists of more than 155 facilities located in more than 30 countries worldwide.

Masoneilan Authorized Repair Centers (MARC™) and Consolidated Green Tag™ Centers (GTC) from Baker Hughes offer you responsive and effective service through OEM-certified repairs, innovative valve diagnostics, management, and maintenance programs. Regionally stocked local modules and kits give sites the ability to assemble and test a wide range of final valve configurations from our ValvFAST program.

Each MARC and GTC location is staffed with highly qualified technicians who are specially trained and certified to deliver exceptional product support and technical expertise.



MARC



GTC



ValvFAST

Valve Lifecycle Management

Driving Outcomes

The FPSO industry is evolving, with environmental pressure similar to onshore industries, which must evolve to pursue new frontiers with an increased focus on corporate social responsibility. Reducing emissions and ensuring safety are non-negotiable in the modern economy, while pressure to unlock new growth and improve margins continues to increase. As today's end users seek to modernize and future-proof their operations accordingly, now more than ever, these operators are looking for more than a valve supplier. They are looking for a partner going into the future who can deliver comprehensive Valve Lifecycle Solutions enabling them to deliver on their commitments and to address their toughest operational challenges.

Valve Lifecycle Management

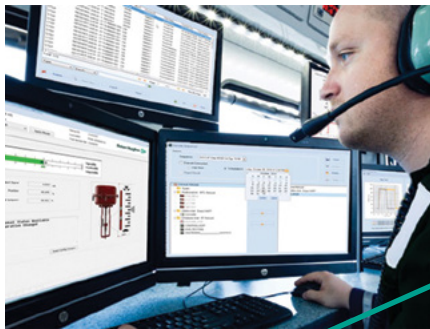

VLM Services

- Asset Management
- Calibration & Tuning
- Monitoring & Diagnostics
- Turnaround Management
- Product Upgrades

Product & Application	Maintenance & Repair	Discrete Monitoring	Continuous Monitoring
Factory Tests	Service Intervals	Digital Positioner Calibration	Distributed Sensors
Quality Data	Repair History	Digital Positioner Diagnostics	Supply Pressure
ERP Production Data	Critical Dimension Measurements	DTM Calibration & Tuning	Temperature
Product Sizing & Configuration	Visual Inspection	EVT PRO PRV Functional Test	Friction
Product Design	As Received vs. Shipped	ValScope-Pro Control Valve Test	RMS Error
			Overshoot

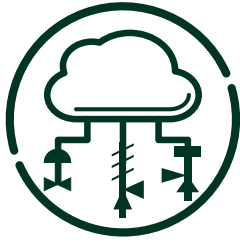

ValvKeep

Valve Asset Management software application to track and manage all valve assets throughout the entire lifecycle.

- Valve Repair Quality System
- Brand Agnostic
- Service & Repair History
- Turnaround Planning
- Documents & Reports
- On-Demand Photos & Data

ValvAware

Remote, on-line valve health monitoring service enabling condition-based monitoring in real process conditions without production interruption.

- Read Only Secure Operations
- Brand Agnostic
- Reports Turn Data into Action
- 16 KPI & Performance Trending
- Compatible with OPC & DCS

ValVue3

Device Type Manager (DTM) application performs the configuration, calibration, and performance testing of your Masoneilan digital devices.

- One Click Calibration Auto-Tunes Positioner to any Control Valve
- Run Remote Diagnostics
- Integrate with AMS, PRM, & FDM



ValScope-Pro

In-line or offline control valve diagnostics and troubleshooting device to evaluate & optimize control valve performance and loop efficiency.

- Complete Control Valve Signature within Minutes
- Graphical Interface to Visualize
- Portable for in-line or in-house uses
- Rugged Durable Construction

EVT PRO

In-situ pressure relief valve portable testing device to confirm valve set pressure in process and under normal operating conditions.

- Ensure PRV Set Pressure is Calibrated
- Portable for in-situ use
- Perform Test Without Shut-Down
- Rugged Durable Construction

ValvStream

Valve sizing & selection tool for Pressure Relief Valves and Control Valves to guide the proper selection of the right valve for the right application.

- Guided Valve Selection
- Sizing & Calculation Sheets
- Drawing
- Bill of Materials
- Specify Special Certs & Tests

Find the nearest local Channel Partner in your area:

valves.bakerhughes.com/contact-us

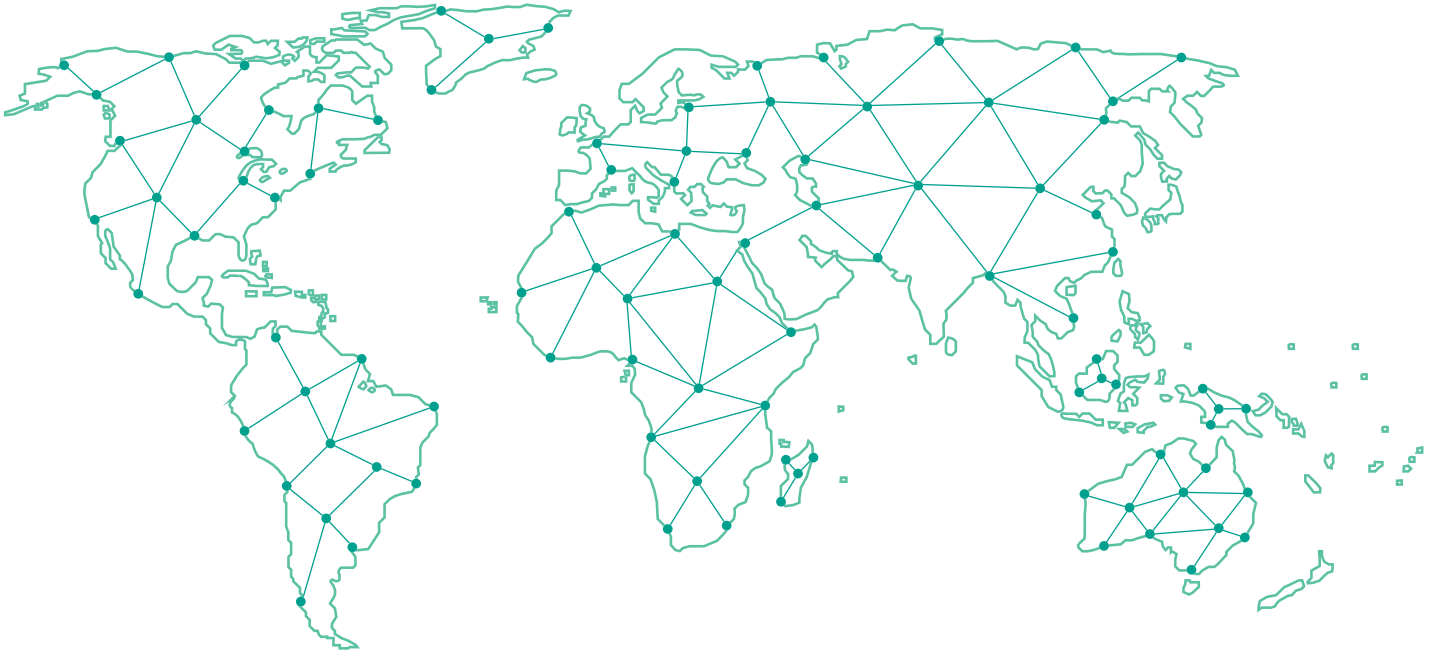

Tech Field Support & Warranty:

Phone: +1-866-827-5378

valvesupport@bakerhughes.com

valves.bakerhughes.com

Baker Hughes 