

# T5/T5MAX Flare Gas Transducer

(Standard and Extended Velocity Range)

Installation Guide





# **T5/T5MAX Flare Gas Transducer**

*(Standard and Extended Velocity Range)*

## **Installation Guide**

BH045C21 Rev. G  
April 2024

[panametrics.com](https://panametrics.com)

Copyright 2024 Baker Hughes company.

This material contains one or more registered trademarks of Baker Hughes Company and its subsidiaries in one or more countries. All third-party product and company names are trademarks of their respective holders.

[no content intended for this page]



## Services



Panametrics provides customers with an experienced staff of customer support personnel ready to respond to technical inquiries, as well as other remote and on-site support needs. To complement our broad portfolio of industry-leading solutions, we offer several types of flexible and scalable support services including: Training, Product Repairs, Service Agreements and more.

Please visit <https://www.bakerhughes.com/panametrics/panametrics-services> for more details.

## Typographical Conventions

**Note:** These paragraphs provide information that provides a deeper understanding of the situation, but is not essential to the proper completion of the instructions.

**IMPORTANT:** These paragraphs provide information that emphasizes instructions that are essential to proper setup of the equipment. Failure to follow these instructions carefully may cause unreliable performance.



**CAUTION!** This symbol indicates a risk of potential minor personal injury and/or severe damage to the equipment, unless these instructions are followed carefully.



**WARNING!** This symbol indicates a risk of potential serious personal injury, unless these instructions are followed carefully.

## Safety Issues



**WARNING!** It is the responsibility of the user to make sure all local, county, state and national codes, regulations, rules and laws related to safety and safe operating conditions are met for each installation.



**Attention European Customers!** To meet CE Mark requirements for all units intended for use in the EU, all electrical cables must be installed as described in this manual.

## Auxiliary Equipment

### Local Safety Standards

The user must make sure that he operates all auxiliary equipment in accordance with local codes, standards, regulations, or laws applicable to safety.

### Working Area



**WARNING!** Auxiliary equipment may have both manual and automatic modes of operation. As equipment can move suddenly and without warning, do not enter the work cell of this equipment during automatic operation, and do not enter the work envelope of this equipment during manual operation. If you do, serious injury can result.



**WARNING!** Make sure that power to the auxiliary equipment is turned OFF and locked out before you perform maintenance procedures on this equipment.

## Qualification of Personnel

Make sure that all personnel have manufacturer-approved training applicable to the auxiliary equipment.

## Personal Safety Equipment

Make sure that operators and maintenance personnel have all safety equipment applicable to the auxiliary equipment. Examples include safety glasses, protective headgear, safety shoes, etc.

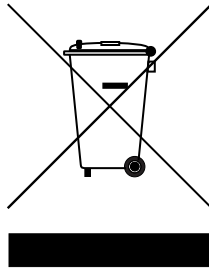
## Unauthorized Operation

Make sure that unauthorized personnel cannot gain access to the operation of the equipment.

## Environmental Compliance

### Waste Electrical and Electronic Equipment (WEEE) Directive

Panametrics is an active participant in Europe's *Waste Electrical and Electronic Equipment (WEEE)* take-back initiative, directive 2012/19/EU.



The equipment that you bought has required the extraction and use of natural resources for its production. It may contain hazardous substances that could impact health and the environment.

In order to avoid the dissemination of those substances in our environment and to diminish the pressure on the natural resources, we encourage you to use the appropriate take-back systems. Those systems will reuse or recycle most of the materials of your end of life equipment in a sound way.

The crossed-out wheeled bin symbol invites you to use those systems.

If you need more information on the collection, reuse and recycling systems, please contact your local or regional waste administration.

Please visit [www.bakerhughesds.com/health-safety-and-environment-hse](http://www.bakerhughesds.com/health-safety-and-environment-hse) for take-back instructions and more information about this initiative.

**Chapter 1. Installing Pipe Nozzles**

1.1 Introduction .....1

    1.1.1 Identifying and Checking the Nozzle Installation Kit Components ..... 2

    1.1.2 Selecting and Marking the Pipe for Nozzle Locations ..... 4

    1.1.3 Installing the First Welding Boss ..... 8

    1.1.4 Installing the First Nozzle ..... 9

    1.1.5 Installing the Second Welding Boss ..... 11

    1.1.6 Installing the Second Nozzle ..... 13

    1.1.7 Hot Tapping the Pipe ..... 14

        1.1.7.1 Hot Tapping For 3" Flanges ..... 14

        1.1.7.2 Hot Tapping For 2" Flanges ..... 14

    1.1.8 Cold Tapping the Pipe ..... 14

1.2 Tilted 45° Installation ..... 15

    1.2.1 Identifying and Checking the Nozzle Installation Kit Components ..... 15

    1.2.2 Selecting and Marking the First Nozzle Location ..... 16

    1.2.3 Determining and Marking the Second Nozzle Location ..... 18

    1.2.4 Installing the First Welding Boss ..... 21

    1.2.5 Installing the First Nozzle ..... 23

    1.2.6 Installing the Second Welding Boss and Nozzle ..... 25

    1.2.7 Hot Tapping the Pipe ..... 26

        1.2.7.1 Hot Tapping For 3" Flanges ..... 26

        1.2.7.2 Hot Tapping For 2" Flanges ..... 26

    1.2.8 Cold Tapping the Pipe ..... 26

**Chapter 2. Installing the Isolation Valves**

2.1 Bias 90° Installation (Standard or Extended Velocity Range) ..... 27

    2.1.1 For 3 inch Flanges ..... 27

    2.1.2 For 2 inch Flanges ..... 27

2.2 Tilted 45° Installation (Standard Velocity Range) ..... 27

    2.2.1 For 3 inch Flanges ..... 27

    2.2.2 For 2 inch Flanges ..... 27

2.3 Tilted 45° Installation (Extended Velocity Range) ..... 28

**Chapter 3. Installing the Transducer Assemblies**

3.1 Introduction ..... 31

3.2 Using the Low-Pressure Insertion Mechanism ..... 31

    3.2.1 Preparing for Installation ..... 31

    3.2.2 Mounting the Insertion Mechanism ..... 31

3.3 Mounting the Bias 90 Insertion Mechanism/Transducer Assembly ..... 36

3.4 Inserting the Bias 90 Transducer into the Pipe ..... 39

3.5 Aligning the Transducers (Standard Velocity Range) ..... 42

3.6 Aligning the Transducers (Extended Velocity Range) ..... 42

3.7 Mounting the Tilted 45 Insertion Mechanism/Transducer Assembly ..... 46

3.8 Inserting the Tilted 45 Transducer into the Pipe ..... 52

3.9 Connecting an XAMP ..... 54

**Chapter 4. Specifications**

4.1 T5/T5 MAX Transducer Physical Specifications ..... 59

4.2 T5/T5MAX Transducer Certifications ..... 59

4.3 Specific conditions of use ..... 60

[no content intended for this page]

# Chapter 1. Installing Pipe Nozzles

## 1.1 Introduction

Before the T5 transducers can be installed into the pipe, you will need to install pipe nozzles. Nozzles may be installed as part of a fabricated spoolpiece or by using the hot or cold tap process with a Panametrics *Nozzle Installation Kit*.

**IMPORTANT:** This procedure only applies if you are using a Nozzle Installation Kit. If you are tapping the pipe without using a Nozzle Installation Kit, refer to the supplied drawings in your shipment. This procedure is written and illustrated for installations on horizontal pipes. However, the procedure is the same for vertical pipe installations.



**WARNING!** Please follow all applicable site, local, and regional safety measures when conducting tapping of nozzles to pipe. Great care should be taken to ensure activity is not being conducted in a flammable environment without proper mitigation strategies.



**WARNING!** Any deviation from this prescribed procedure can result in accidental release of process gas that may be dangerous or hazardous due to its pressure, flammability, or composition. Safe work practices should be followed and periodic review of this procedure is highly recommended before conducting this work.

This section describes how to install nozzles in the following configurations:

### 1. Bias 90° Installation

- Standard transducer spacings of 10" and 9", with both transducers facing straight at each other, are for applications with gas velocities up to 100 m/s (328 ft/s). This is the standard velocity range.
- A shorter transducer spacing of 6.4", with only the downstream transducer rotated 6° into the flow is for applications with gas velocities up to 120 m/s (394 ft/s). This is the extended velocity range.

### 2. Tilted 45° Installation

- Standard transducer face to face spacings, with both transducer body axes concentric and parallel to each other are for applications with gas velocities up to 100 m/s (328 ft/s). This is the standard velocity range.
- A shorter transducer face to face spacing of approximately 7.85", with only the downstream transducer tilted 6° into the flow, is for applications with gas velocities up to 120 m/s (394 ft/s). This is the extended velocity range.

### Bias 90° Installation

This procedure includes the following steps:

- Identifying and checking the nozzle installation kit components
- Selecting and marking the pipe for nozzle locations
- Installing the first welding boss
- Installing the first nozzle
- Installing the second welding boss
- Installing the second nozzle
- Tapping the pipe

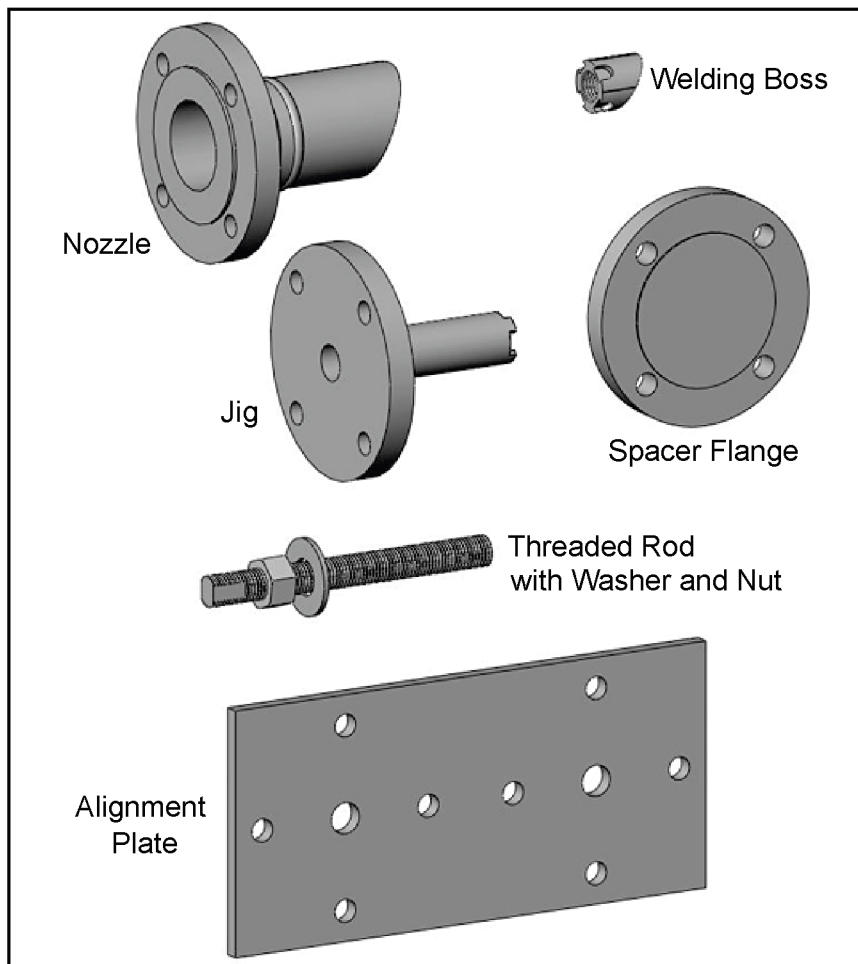
### 1.1.1 Identifying and Checking the Nozzle Installation Kit Components

The *Nozzle Installation Kit* contains the materials listed below. Use *Figure 1* below to help identify each component.

- 2 Nozzles (if purchased)
- 2 Welding bosses
- 1 Jig
- 1 Alignment plate (9", 10" or 6.4" spacing)
- 1 Spacer flange
- 1 Threaded rod (1" diameter), with washer and nut

**IMPORTANT:** You will need eight 5/8" studs with two nuts each, or 3/4" studs with two nuts each. The 5/8" studs are needed for 2"-150#, 2"-300# and 3"-150# flanges. The 3/4" studs are needed for 3"-300# flanges.

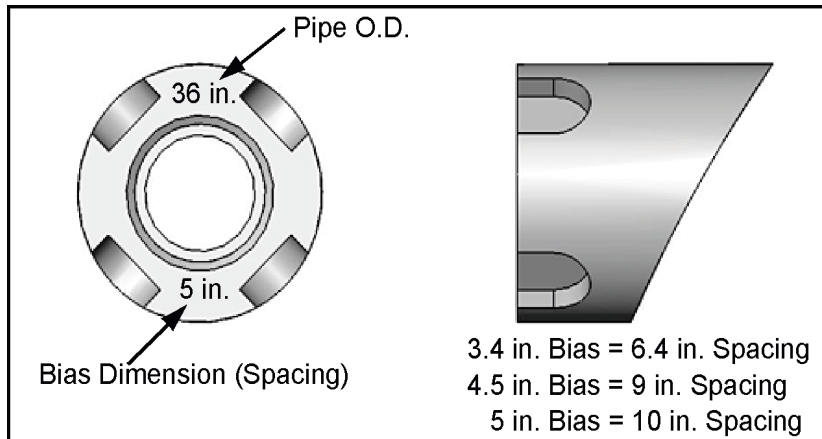
After you are familiar with each component, verify that the welding bosses and alignment plate shipped are for the required transducer spacing and the pipe size described in the following steps.



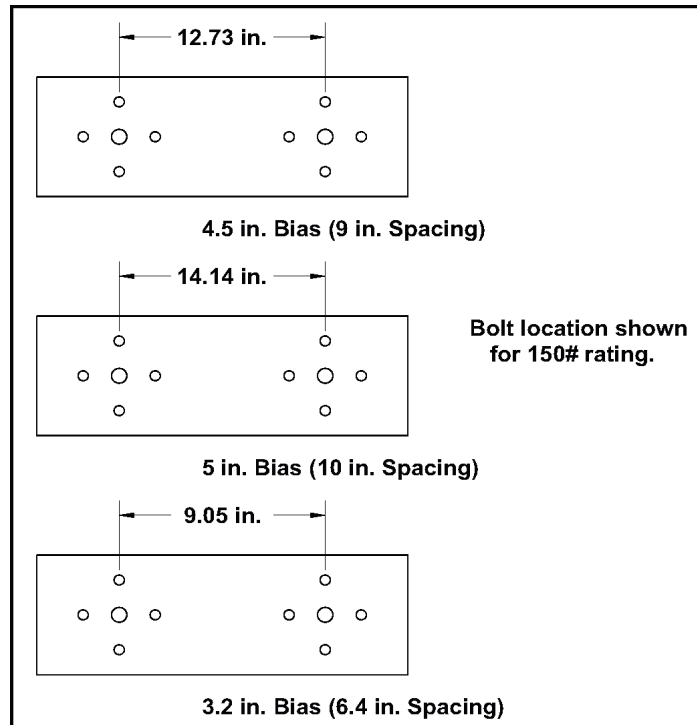
**Figure 1: Components for Nozzle Installation Kit**

1. Check the marking on the end of the welding boss. The pipe O.D. and the *bias dimension* (i.e., the *transducer spacing*) are engraved on the boss as shown below. Typically,
  - For flow velocities up to 100 m/s (328 ft/s), the 10 in. spacing is used on pipes 18 in. (450 mm) in diameter or larger, while the 9 in. spacing is used on pipes 16 in. (400 mm) in diameter or on larger pipes when attenuating gases are present.
  - For flow velocities up to 120 m/s (394 ft/s), the 6.4 in. spacing is used on pipes 14 in. (356 mm) in diameter or larger.

**Note:** *Bias dimension* refers to the distance between the center of the nozzle location and the center line of the pipe.



2. Check the spacing between the holes on the alignment plate, as shown below. The dimensions should correspond to the bias/spacing dimension on the welding boss.



## 1.1.2 Selecting and Marking the Pipe for Nozzle Locations

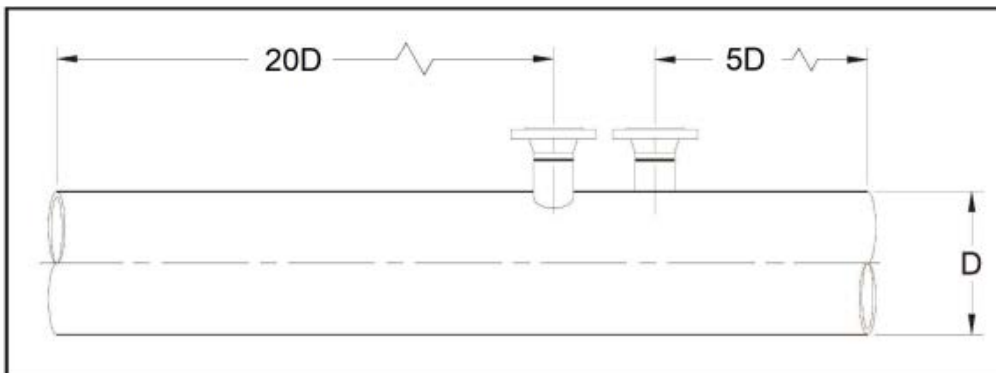


**CAUTION!** Correct nozzle alignment is critical to the successful operation of the flowmeter. Therefore, all marking, positioning and welding operations must be carried out with the utmost attention to accuracy. Unless otherwise stated, dimensional positioning of the nozzles must be held to a tolerance of  $\pm 1/16$  in. ( $\pm 1.6$  mm) relative to each other and with respect to the pipe centerline. The angular tolerance must be held to  $\pm 1^\circ$ . All hole cutting in process piping must be performed using hot tapping equipment.

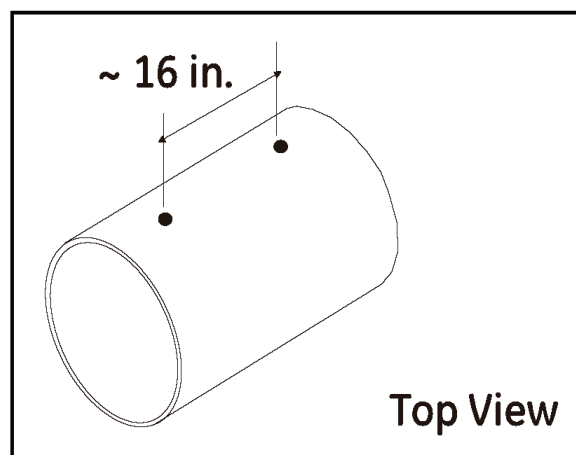


**WARNING!** Be sure to adhere to all applicable safety regulations.

1. For optimum performance, you should select a location that has at least 20 pipe diameters of straight, undisturbed flow upstream and 5 pipe diameters of straight, undisturbed flow downstream from the point of measurement. Undisturbed flow means avoiding sources of turbulence such as flanges, elbows and tees; avoiding swirl; and avoiding disturbed flow profiles. Never install the flowmeter downstream of control valves, especially butterfly valves. If you cannot find a proper location, please consult with Panametrics Flow Application engineering.

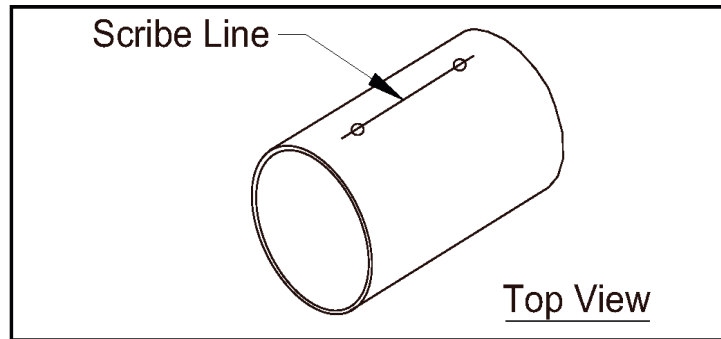


2. Use a center finder device to locate the center of the pipe. **“EYEBALLING” IS NOT ADEQUATE FOR ACCURATE FLOW MEASUREMENT!**
3. Lightly punch two marks approximately 16 in. apart on the top of the pipe, running along the center line. The two nozzle locations will be located between these two center punch marks.

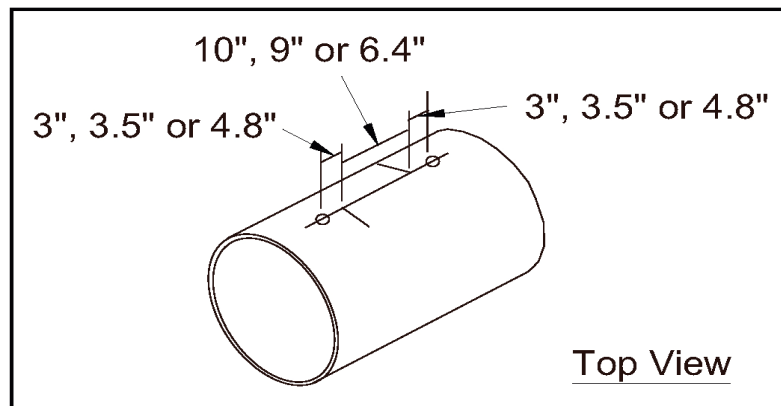




4. Spray the area between the two punch marks on the top of the pipe with a marking dye product. Using a metal straight edge, scribe a line between the two punch marks.

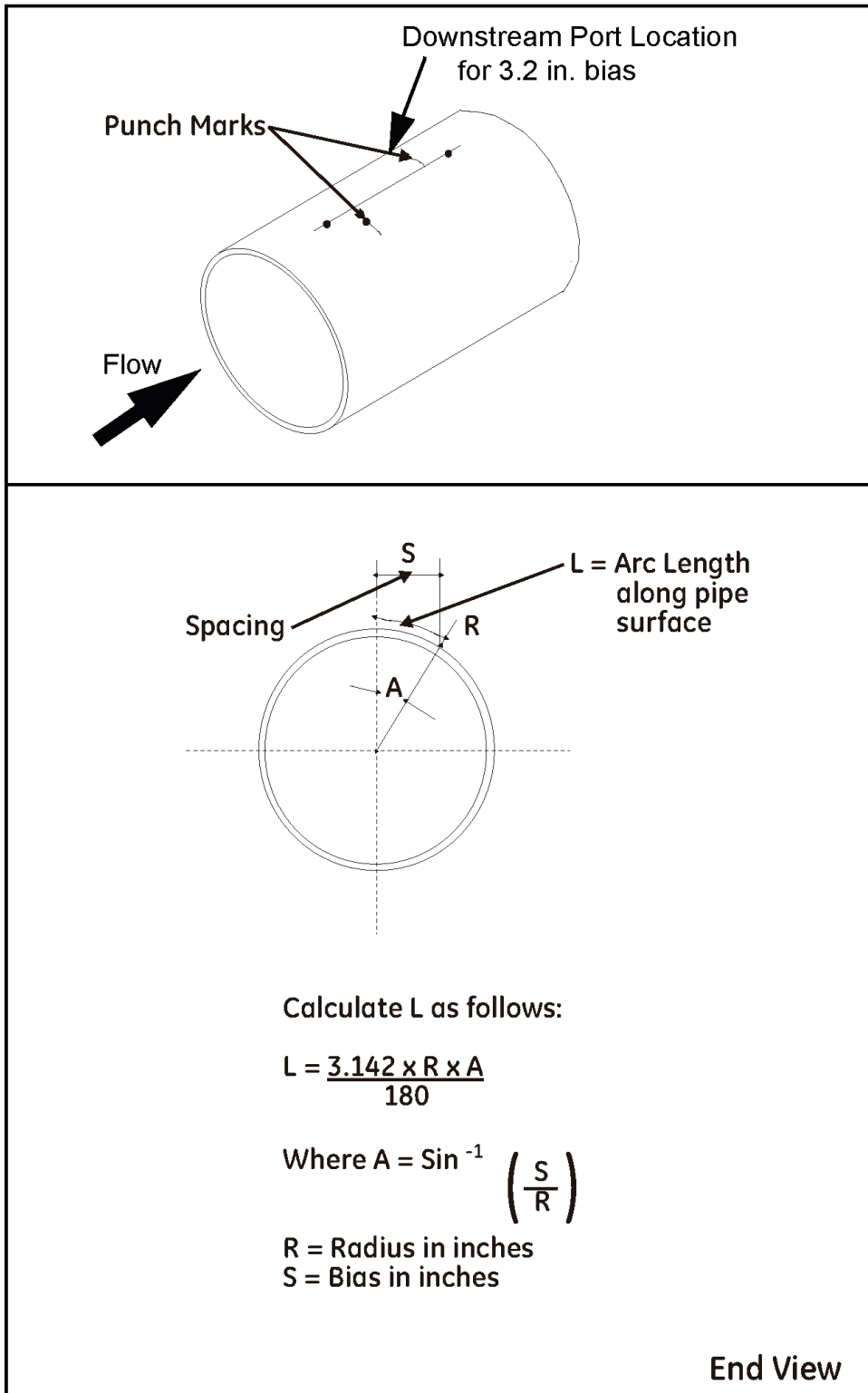


5. Along the new scribe line, mark off a length equal to your transducer spacing (10 in., 9 in. or 6.4 in.) and scribe two lines at least 10 in. in length and perpendicular to the scribe line on different sides of the scribe line.



6. Along each of the perpendicular scribe lines, lightly punch a mark at a distance equal to half of your transducer spacing (5 in., 4.5 in. or 3.2 in.) from the center line, depending on the bias distance for your transducers. Keep in mind that the distance along the arc of the pipe (L) from the pipe centerline is slightly greater than the point-to-point distance through the pipe. These marks pinpoint the centers for the nozzles. Refer to Table 1 on page 7 for arc distances for the most commonly used pipe sizes. If your pipe size is not shown in Table 1, use the equation in the figure on page 6 to calculate the arc distance.

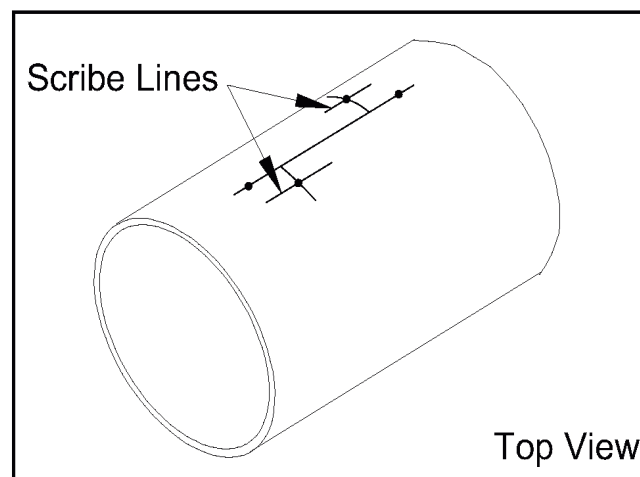
**IMPORTANT:** For a 3.2 in. bias distance, the downstream port must be located on the right side of the long scribe line when viewed from the downstream end of the pipe (see the figure below). This convention is mandatory for the 6.4 in. transducer spacing and is optional (not required) for a 10 in. or 9 in. spacing.



**Table 1: Calculated Arc Distances for Common Pipe Sizes**

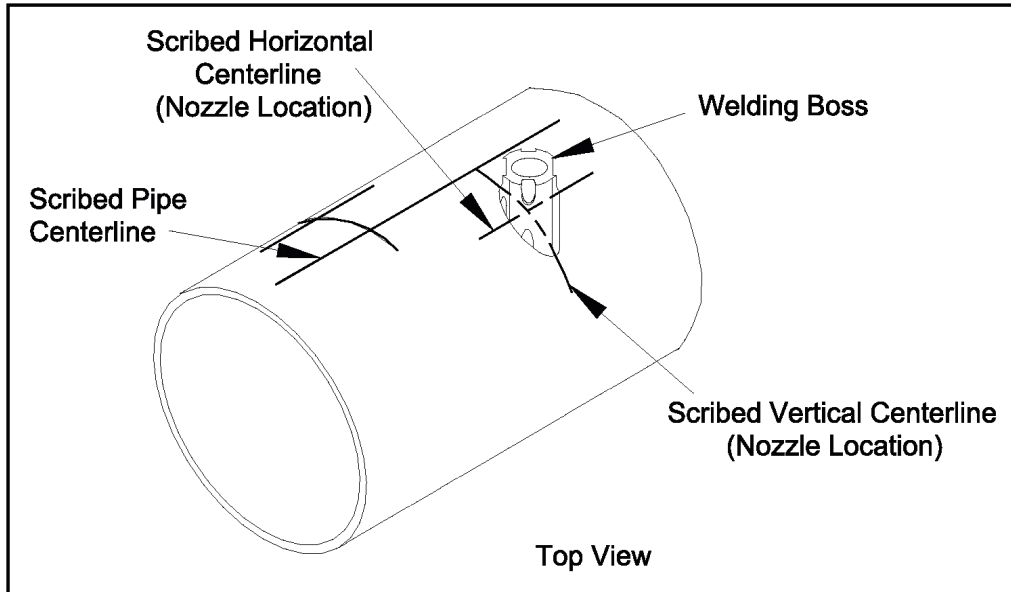
Pipe O.D.	Arc Distance
5 in. Bias	
18 in. (450 mm)	5.301 in. (134.6 mm)
24 in. (600 mm)	5.157 in. (131.0 mm)
30 in. (750 mm)	5.098 in. (129.5 mm)
36 in. (900 mm)	5.067 in. (128.7 mm)
42 in. (1050 mm)	5.048 in. (128.2 mm)
4.5 in. Bias	
16 in. (400 mm)	4.779 in. (121.4 mm)
18 in. (450 mm)	4.713 in. (119.7 mm)
24 in. (600 mm)	4.613 in. (117.2 mm)
30 in. (750 mm)	4.571 in. (116.1 mm)
36 in. (900 mm)	4.549 in. (115.5 mm)
42 in. (1050 mm)	4.536 in. (115.2 mm)
3.2 in. Bias	
14 in. (350 mm)	3.323 in. (84.4 mm)
16 in. (400 mm)	3.292 in. (83.6 mm)
18 in. (450 mm)	3.272 in. (83.1 mm)
24 in. (600 mm)	3.239 in. (82.3 mm)
30 in. (750 mm)	3.225 in. (81.9 mm)
36 in. (900 mm)	3.217 in. (81.7 mm)
42 in. (1050 mm)	3.213 in. (81.6 mm)

7. Scribe a 6 in. long horizontal centerline through each nozzle center location point and parallel to the original centerline.



### 1.1.3 Installing the First Welding Boss

1. Each welding boss has four scribe marks indicating the center of the bias. Take one welding boss and line up its scribe marks with the horizontal and perpendicular scribe marks on the pipe as shown below. Make sure you position the boss on the pipe so that the contoured end of the boss matches the pipe arc. That is, the shorter side of the boss should be closer to the original scribed pipe centerline.



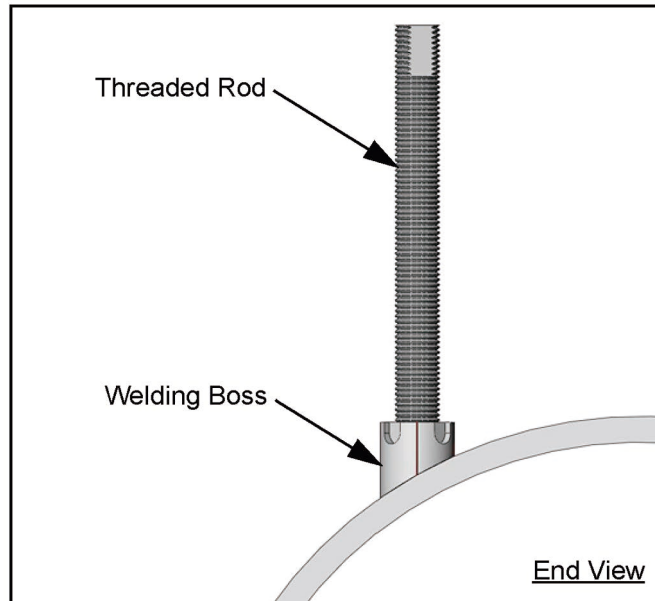
2. Clamp the boss in place, using a pipe strap or equivalent, so that it cannot move during tack welding.
3. Check the boss alignment again, and then tack weld the boss in each of the four grooves between the boss scribe marks. Make sure you keep the boss contour flush with the pipe contour during the entire tack welding operation. The boss is constructed of carbon steel.
4. Check the alignment again. If the boss is misaligned by 0.02 in. (0.5 mm) or more, remove the boss, grind off the welds and reinstall the boss.

### 1.1.4 Installing the First Nozzle

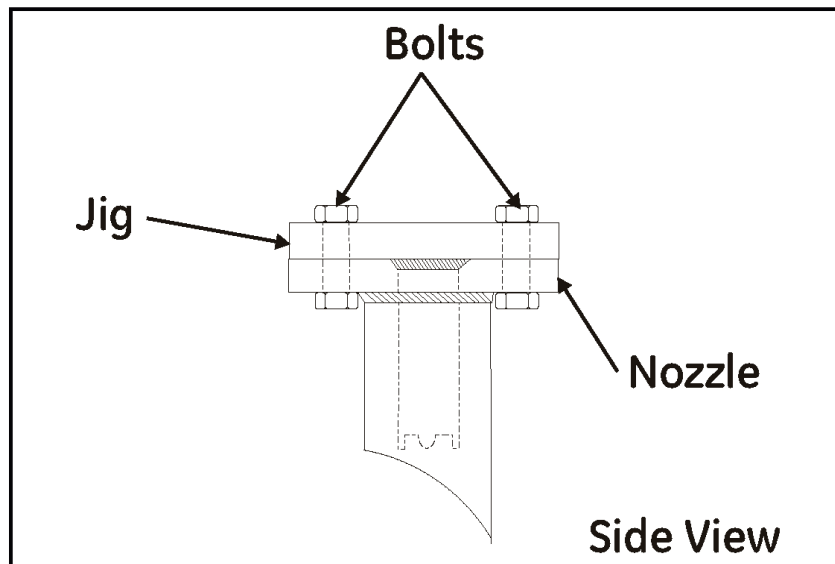


**CAUTION!** It is essential that the nozzles are set up and fixed in position using the jig and alignment plate provided, prior to welding the nozzle.

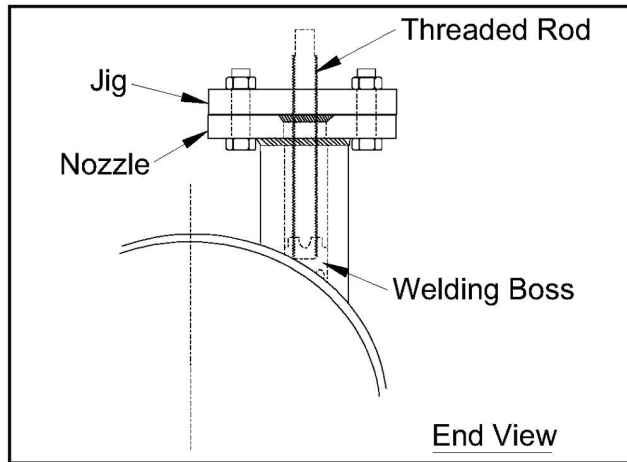
1. Screw the threaded rod into the boss that is welded onto the pipe. If necessary, remove the washer and nut from the threaded rod.



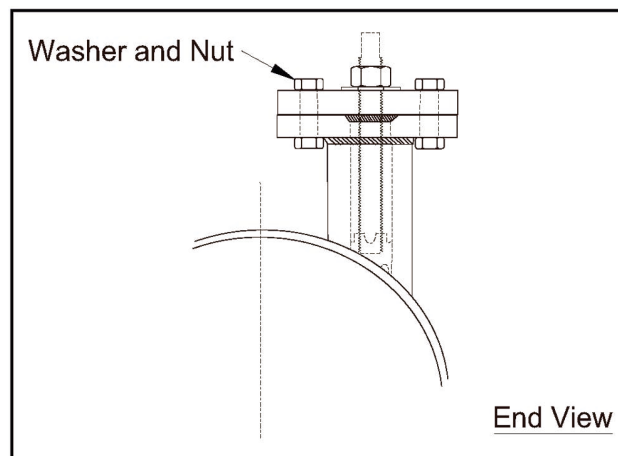
2. Insert the pipe section of the jig (the key cut section) into the pipe section of the nozzle, and fasten the assembly together using four nuts and bolts.



3. Slide the jig/nozzle assembly over the threaded rod, fitting the jig into the key cut end of the welding boss while aligning the contoured end of the nozzle to the pipe arc.



4. Align the nozzle scribe marks with the pipe scribe marks and tighten the assembly in place using the 1-in. washer and nut provided. If slight misalignment occurs between the nozzle scribe marks and pipe scribe marks, loosen the four bolts holding the jig and nozzle assembly, and rotate the nozzle for the best alignment. After the nozzle has been accurately aligned, retighten the four bolts.



5. The jig, boss, and nozzle assembly is designed to provide a 0.094 in. (2.4 mm) root gap between the beveled edge of the nozzle and the outside diameter of the pipe. If this gap is not present all the way around the nozzle, the nozzle must be removed and ground appropriately to provide the required clearance. If the root gap is larger than the 0.094 in. (2.4 mm) dimension evenly all the way around the nozzle, then suitably sized washers may be inserted between the jig and the nozzle to reduce the root gap dimension.

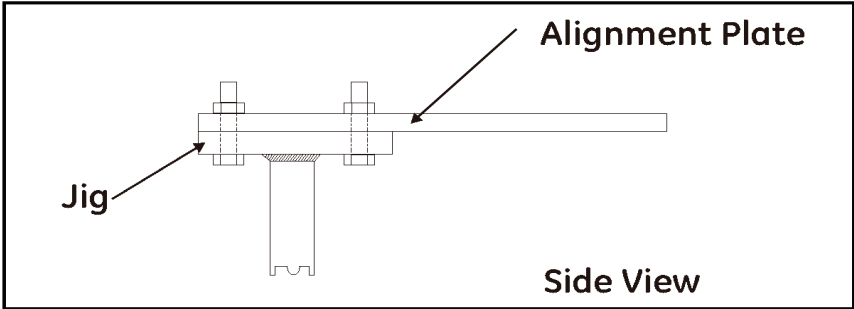


**WARNING!** Only qualified personnel should weld bosses and nozzles, using a suitable ASME IX qualified welding procedure. All applicable safety codes should be observed.

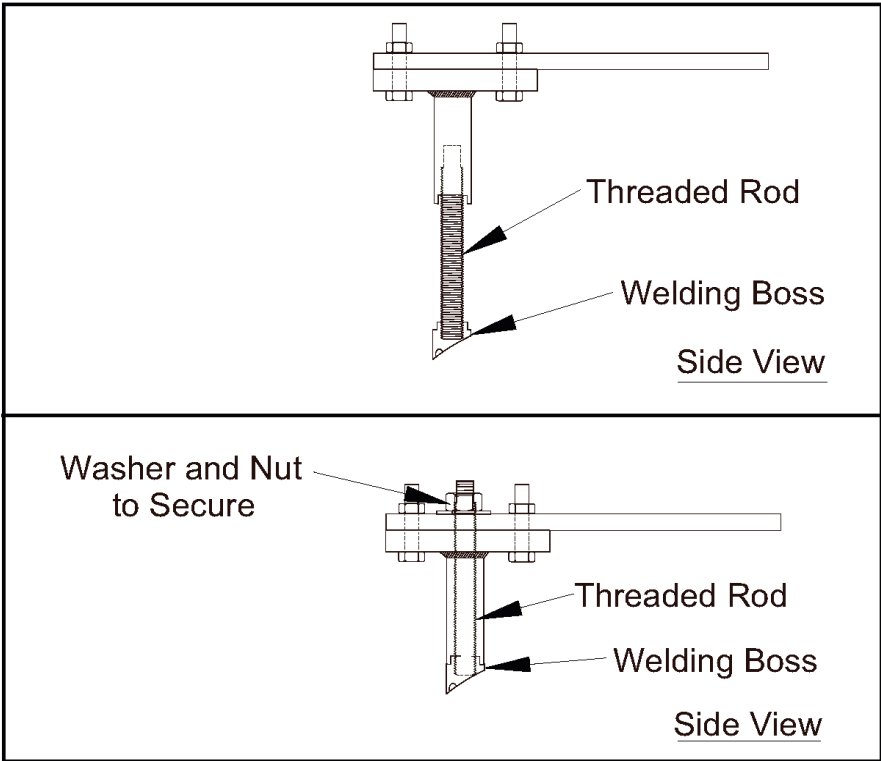
6. Tack weld the nozzle to the pipe at four diametrically opposed points, each tack being approximately 0.2 in. (5 mm) in length. Allow the weld to cool for 30 seconds between tacks.
7. Complete the root pass and subsequent filler passes as required.
8. Allow the weld to cool, and then remove the nut, washer, jig and threaded rod.

**1.1.5 Installing the Second Welding Boss**

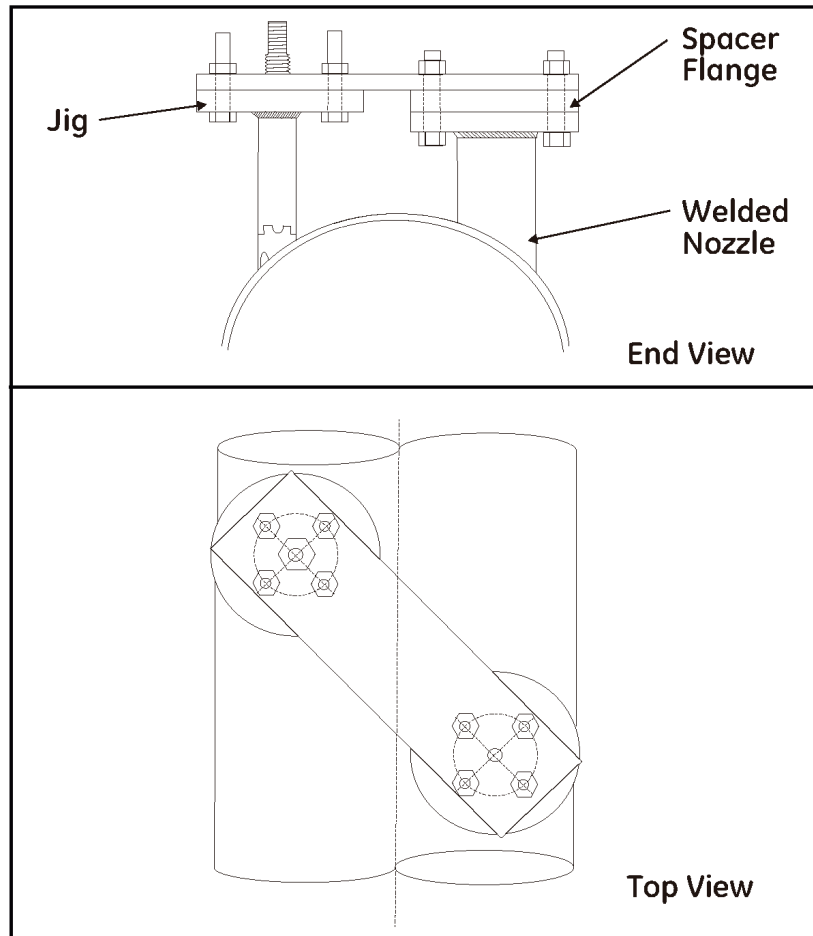
- 1. Bolt the jig to one end of the alignment plate using four bolts.



- 2. Screw the threaded rod into the second boss. Then, insert the bolt/boss assembly into the jig key cut grooves and secure it with a washer and nut on top.



3. Remember to orient the boss in the jig to maintain the proper contour location to the pipe for installation.
4. Place the spacer flange on top of the welded nozzle and then mount the second end of the alignment plate on top of the spacer flange. Bolt the alignment plate into position with the remaining bolts.



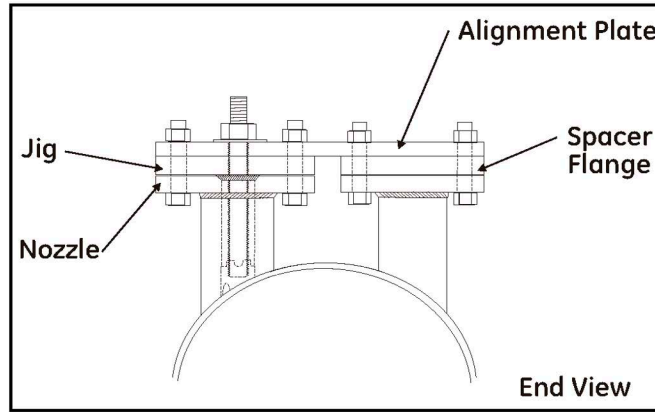
5. The second welding boss should now be positioned over the second nozzle location scribe marks. Align the boss scribe marks with the pipe scribe marks, and then tighten all of the nuts securely.
6. Check the boss alignment again, then tack weld the boss in each of the four grooves between the boss scribe marks.
7. After tacking, check the boss alignment once more. If the boss is misaligned by 0.02 in. (0.5 mm) or more, remove the boss by grinding off the welds, and then reinstall the boss.
8. Remove the threaded rod and the jig. Leave the alignment plate bolted to the first nozzle, with the spacer flange sandwiched between them.



### 1.1.6 Installing the Second Nozzle

To install the second nozzle, complete the following steps:

1. Insert the jig into the second nozzle and position this assembly over the boss and under the alignment plate. Then, insert the threaded rod.

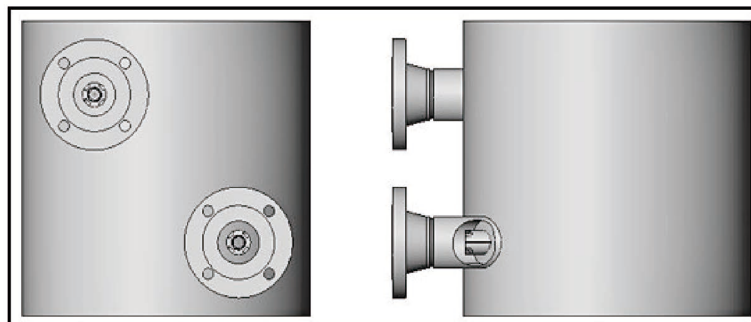


2. The jig, boss, and nozzle assembly is designed to provide a 0.094 in. (2.4 mm) root gap between the beveled edge of the nozzle and the outside diameter of the pipe. If this gap is not present all the way around the nozzle, the nozzle must be removed and ground appropriately to provide the required clearance. If the root gap is larger than the 0.094 in. (2.4 mm) dimension evenly all the way around the nozzle, then suitably sized washers may be inserted between the jig and the nozzle to reduce the root gap dimension.
3. Secure the alignment plate by installing the two sets of four bolts on the alignment plate. Also, install the washer and nut on the threaded rod.
4. Line up the nozzle scribe marks with the pipe scribe marks and tighten all the nuts.
5. Make sure the nozzle is still in alignment..



**WARNING!** Only qualified personnel should weld bosses and nozzles, using a suitable ASME IX qualified welding procedure. All applicable safety codes should be observed.

6. Tack weld the nozzle to the pipe at four diametrically opposed points, each tack being approximately 0.2 in. (5 mm) in length. Allow the weld to cool for 30 seconds between tacks.
7. Complete the root pass and subsequent filler passes as required.
8. Allow the weld to cool, and then remove all nuts and bolts, the alignment plate, the jig, the spacer flange and the threaded rod. The completed installation should appear as shown below.



## 1.1.7 Hot Tapping the Pipe



**WARNING!** Hot tapping should only be performed by qualified personnel. Follow all applicable code and safety practices during these procedures.

### 1.1.7.1 Hot Tapping For 3" Flanges

To hot tap the pipe for 3" flanges, complete the following steps:

1. Obtain two suitable 3 in. ANSI flanged isolation valves. The valves should be a full bore type with either 150# RF flanges and a face-to-face length of 8 in. or 300# RF flanges and a face-to-face length of 11.125 in.
2. Install one of the isolation valves, including a suitable gasket, on each of the nozzles. Secure the valves with either 5/8 in. studs and nuts for 150# flanges or 3/4 in. studs and nuts for 300# flanges.
3. Orient the isolation valve handles to minimize interference during operation of the valves.
4. Hot tap holes in the pipe using a hot tap machine equipped with a 3/4 in. (19.05 mm) drill bit.
5. Then use a coupon retaining hole saw to cut a hole with a diameter of 2.36 in. (60 mm) minimum to 2.875 in. (73 mm) maximum.

### 1.1.7.2 Hot Tapping For 2" Flanges

To hot tap the pipe for 2" flanges, complete the following steps:

1. Obtain two suitable 2 in. ANSI flanged isolation valves. The valves should be a full bore type with either 150# RF flanges and a face-to-face length of 7 in. or 300# RF flanges and a face-to-face length of 8.50 in.
2. Install one of the isolation valves, including a suitable gasket, on each of the nozzles. Secure the valves with 5/8 in. studs and nuts.
3. Orient the isolation valve handles to minimize interference during operation of the valves.
4. Hot tap holes in the pipe using a hot tap machine equipped with a 3/4 in. (19.05 mm) drill bit.
5. Then use a coupon retaining hole saw to cut a hole with a diameter of 1.81 in. (46 mm) minimum to 1.89 in. (48 mm) maximum.

## 1.1.8 Cold Tapping the Pipe



**WARNING!** Cold tapping should only be performed by qualified personnel. Follow all applicable code and safety practices during these procedures

The procedure for cold tapping a pipe is the same as the hot tapping procedure described above. However, isolation valves are not necessary during the tapping process. The hot tap machine is used directly on the nozzles. The isolation valves are added after the tapping process has been completed.

## 1.2 Tilted 45° Installation

This procedure includes the following steps:

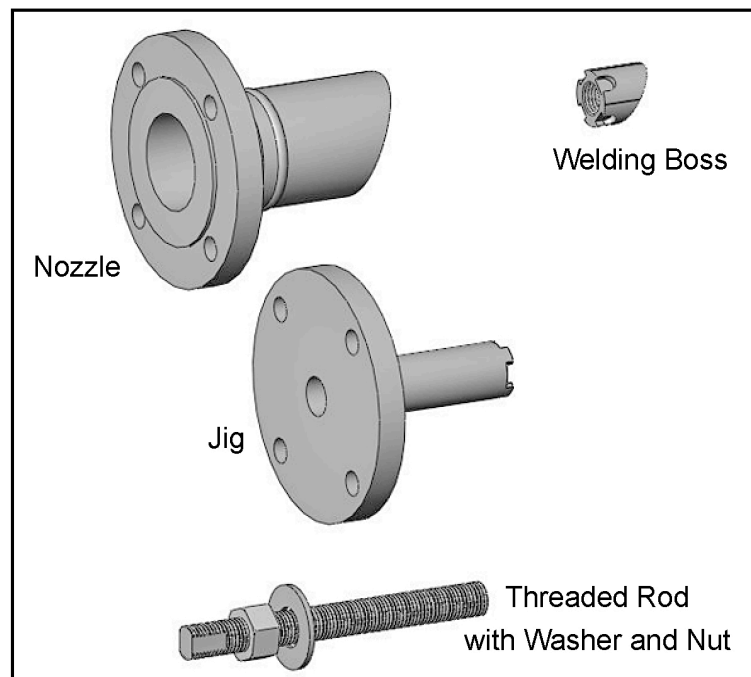
- Identifying and checking the nozzle installation kit components
- Selecting and marking the pipe for nozzle locations
- Installing the first welding boss
- Installing the first nozzle
- Installing the second welding boss
- Installing the second nozzle
- Tapping the pipe

### 1.2.1 Identifying and Checking the Nozzle Installation Kit Components

The *Nozzle Installation Kit* contains the materials listed below. Use Figure 2 below to help identify each component.

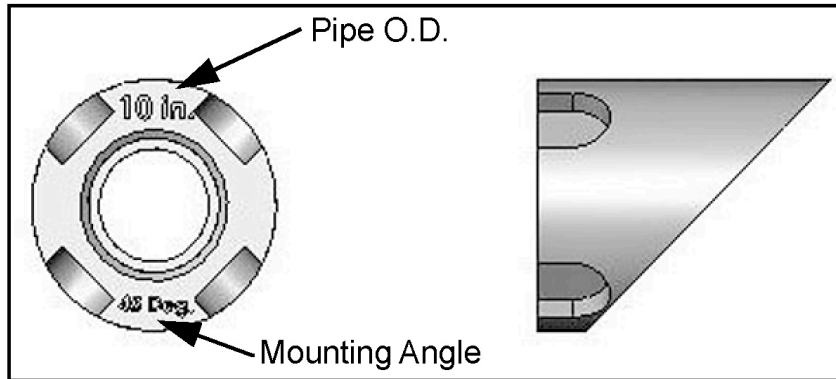
- 2 Nozzles (if purchased)
- 2 Welding bosses
- 1 Jig
- 1 Threaded rod (1" diameter), with washer and nut

**IMPORTANT:** You will need eight 5/8" studs with two nuts each, or 3/4" studs with two nuts each. The 5/8" studs are needed for 2"-150#, 2"-300# and 3"-150# flanges. The 3/4" studs are needed for 3"-300# flanges.



**Figure 2: Components for Nozzle Installation Kit**

Check the markings on the end of the welding boss. The pipe OD and the mounting angle are engraved on the boss, as shown below.



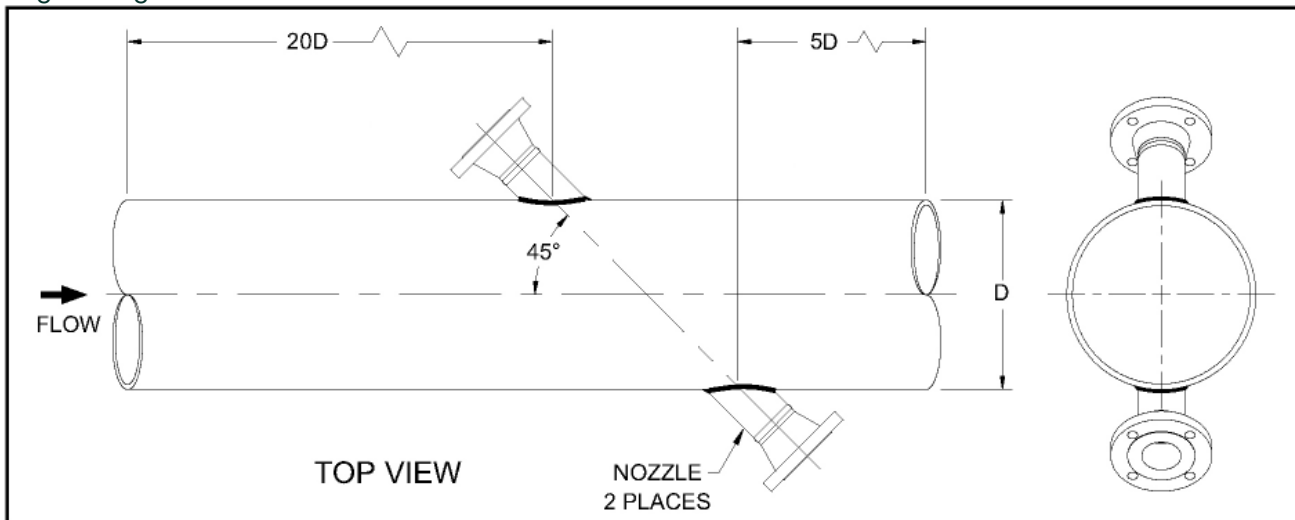
### 1.2.2 Selecting and Marking the First Nozzle Location



#### **CAUTION!**

**Correct nozzle alignment is critical to the successful operation of the flowmeter. Therefore, all marking, positioning and welding operations must be carried out with the utmost attention to accuracy. Unless otherwise stated, dimensional positioning of the nozzles must be held to a tolerance of  $\pm 1/16$  in. ( $\pm 1.6$  mm) relative to each other and with respect to the pipe centerline. The angular tolerance must be held to  $\pm 1^\circ$ . All hole cutting in process piping must be performed using hot tapping equipment.**

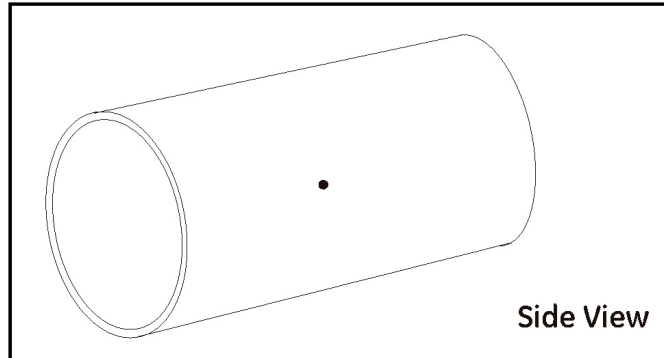
- For optimum performance, you should select a location that has at least 20 pipe diameters of straight, undisturbed flow upstream and 5 pipe diameters of straight, undisturbed flow downstream from the point of measurement. Undisturbed flow means avoiding sources of turbulence such as flanges, elbows and tees; avoiding swirl; and avoiding disturbed flow profiles. Never install the flowmeter downstream of control valves, especially butterfly valves. If you cannot find a proper location, please consult with Panametrics Flow Application engineering.



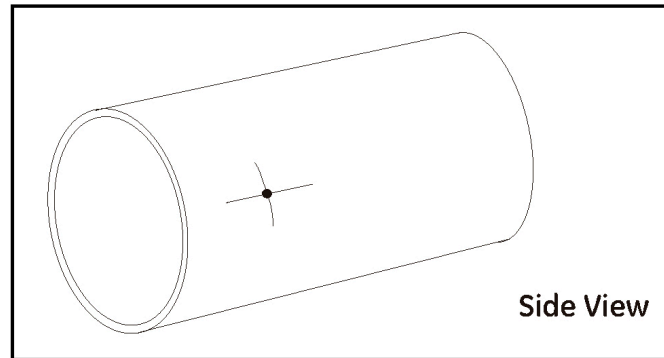
2. Install the pipe nozzles on a pipe diameter as near as possible to the horizontal plane. This would be at the 3 o'clock and 9 o'clock positions for a horizontal pipe.

**Note:** If you cannot find a proper location, please consult with Panametrics Flow Application engineering.

3. At the 3 o'clock position, center punch the pipe to mark the position for the center of the first nozzle.



4. Spray this area with a marking dye product. Using a metal straight edge, scribe 6 in. long vertical and horizontal lines that intersect at the center punch mark.

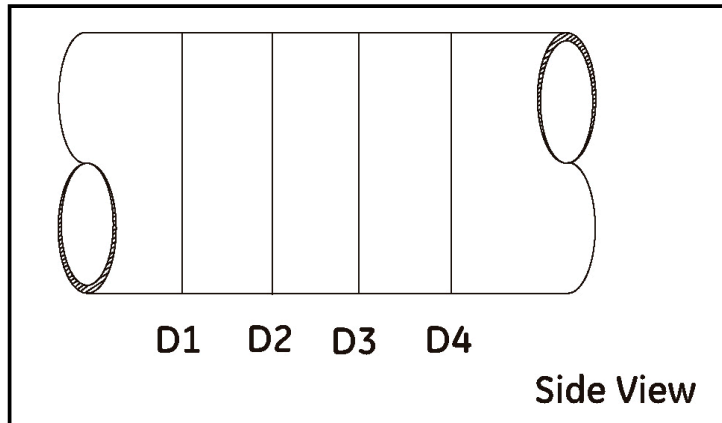


### 1.2.3 Determining and Marking the Second Nozzle Location

1. The second nozzle is located a distance equal to one pipe O.D. along the pipe centerline and on the opposite side of the pipe (180° around the circumference). Spray this area with a marking dye product.

**Note:** For installation angles other than 45°, the distance along the pipe centerline is equal to the pipe O.D. times the tangent of the installation angle.

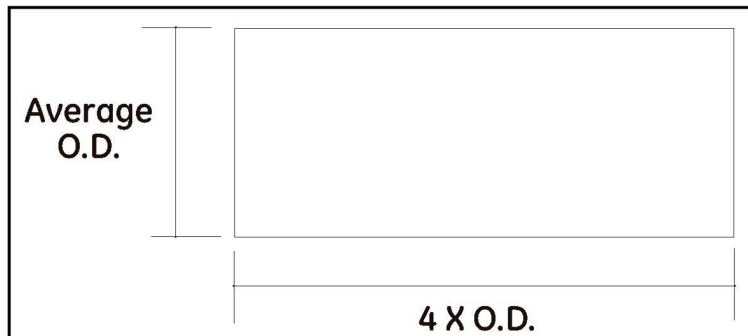
2. To account for possible variations in the O.D. of the pipe, measure the pipe O.D. at four location between the nozzle centers. Calculate the average outside diameter based on these measurements.



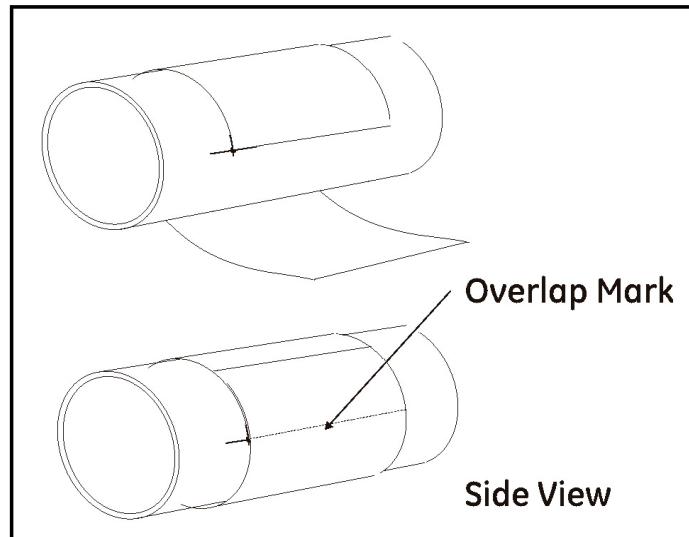
3. Using a roll of polyester film (or equivalent), cut a strip of film to the following width and length:

**IMPORTANT:** Ensure that the sides of the film are cut parallel to each other.

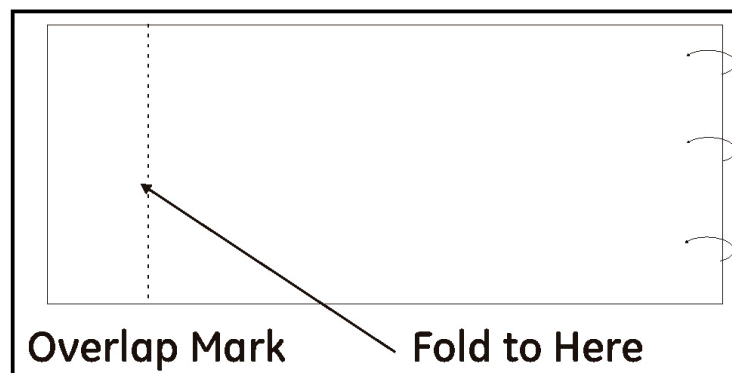
- **Width** – equal to the average pipe O.D., as calculated in Step 1 above.
- **Length** – equal to 4 times the average pipe O.D., as calculated in Step 1 above.



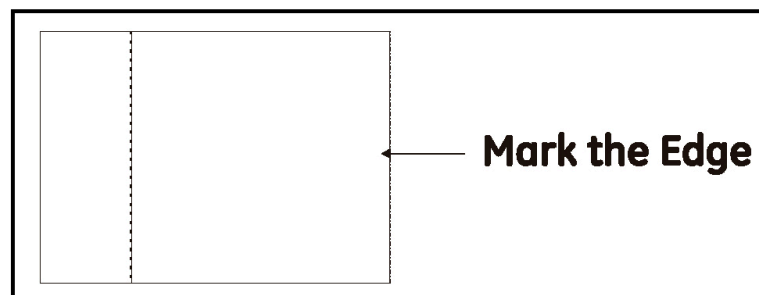
4. Wrap the strip of film around the pipe with one edge running along the vertical scribe line at the first nozzle location. Make sure the strip overlaps squarely all the way around the pipe, and mark the overlap location of the strip. This equals the circumference of the pipe.



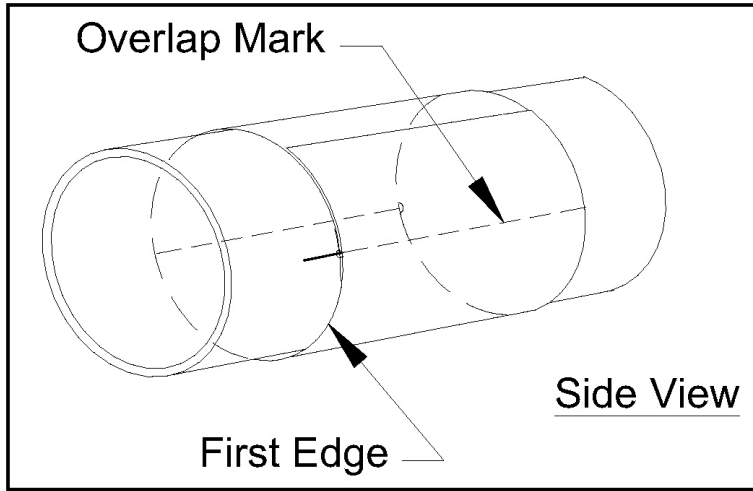
5. Remove the strip of film and fold it as shown below to determine the position which is diametrically opposite the overlap position when the film is reapplied to the pipe.



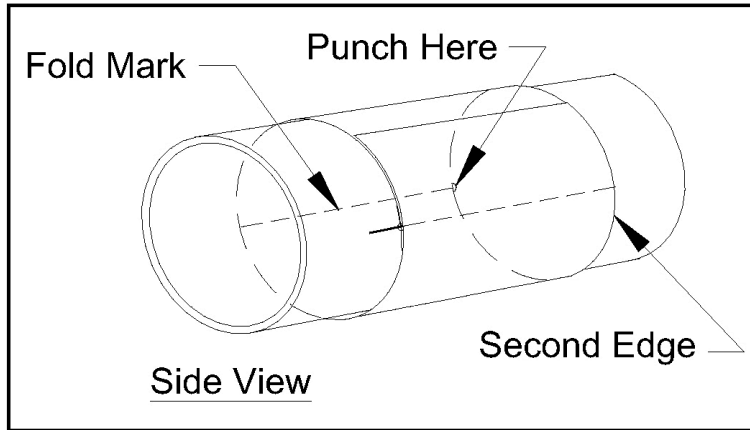
6. Mark the outside of the fold for reference.



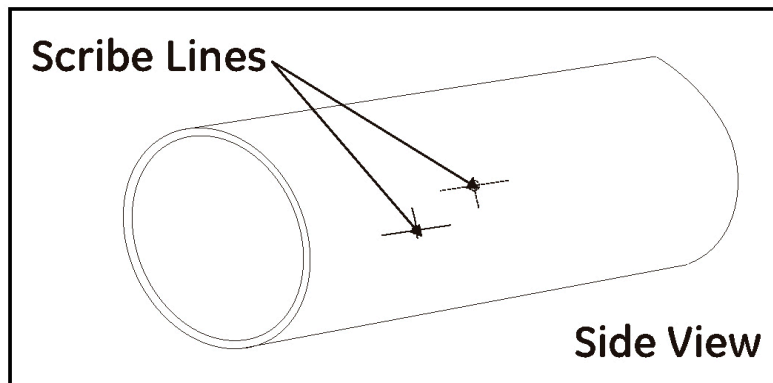
7. Wrap the strip of film around the pipe again. This time, line up the overlap mark with the horizontal and vertical scribe lines. Again, make sure you wrap the strip of film squarely all the way around the pipe.



8. The new location of the center of the second nozzle is now identified as the intersection of the fold line and the second edge of the strip of film. Center punch this location prior to removing the strip of film.



9. Remove the strip of film from the pipe.
10. Scribe 6 in. long vertical and horizontal lines which intersect at the new center-punch mark.





### 1.2.4 Installing the First Welding Boss

- Before welding the first boss, you must add another scribe line known as the oblique center line. The oblique center line compensates for the slope or oblique of the boss. The oblique center line is offset from the true center (vertical) scribe line marked earlier by a distance of X, which is dependent on the pipe outside diameter as follows:

$$X = D/2 - \frac{d/2}{\tan[\sin^{-1}(d/D)]}$$

where, D = pipe outside diameter

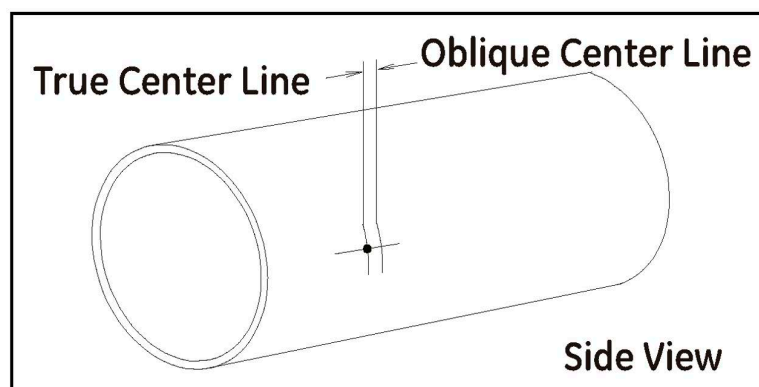
d = welding boss outside diameter (1.660 in.)

Table 2 below shows values of X for various pipe sizes.

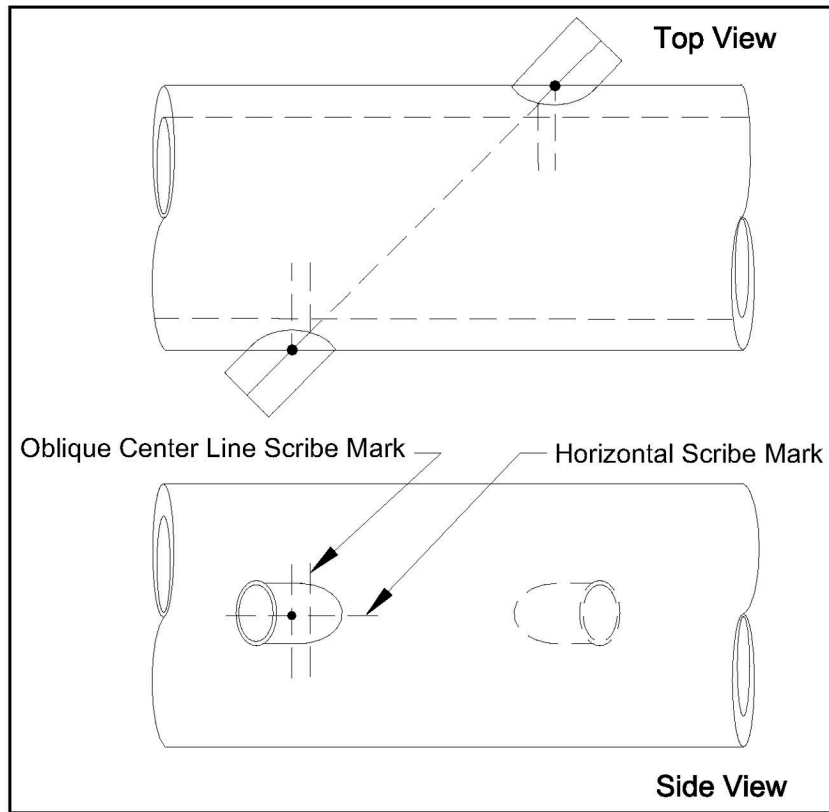
**Table 2: Values for Various Pipe Sizes**

Pipe Size		X Dimensions
NPS (DN)	O.D.	
6 in. (150 mm)	6.625 in. (168 mm)	0.106 in. (2.69 mm)
8 in. (200 mm)	8.625 in. (219 mm)	0.081 in. (2.06 mm)
10 in. (250 mm)	10.750 in. (273 mm)	0.064 in. (1.62 mm)
12 in. (300 mm)	12.750 in. (324 mm)	0.054 in. (1.37 mm)
14 in. (350 mm)	14.000 in. (356 mm)	0.049 in. (1.24 mm)

- Scribe the oblique center line on the pipe at the calculated distance from the true center line. The oblique center line should be marked on the side of the true center line that is closer to the second nozzle location.



3. Position the welding boss such that the four scribe lines on the welding boss are lined up with the horizontal scribe mark and the oblique center line on the pipe. Make sure you orient the boss as shown below.

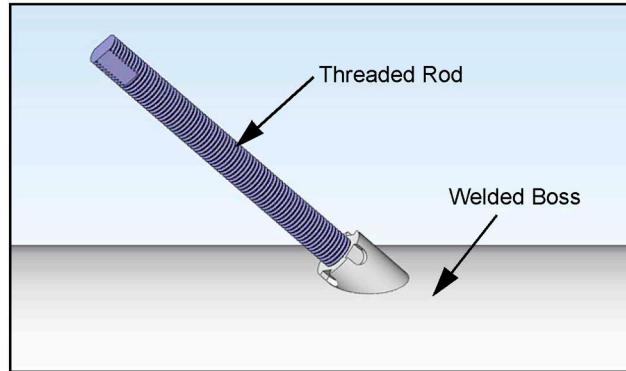


4. Clamp the boss in place using a pipe strap or equivalent so that it cannot move during tack welding.
5. Check the boss alignment, then tack weld the carbon steel boss to the pipe in each of the four grooves between the boss scribe marks.
6. Remove the clamp and check the alignment again. If the boss is misaligned by 0.02 in. (0.5 mm) or more, remove the boss, grind off the welds and reinstall the boss.

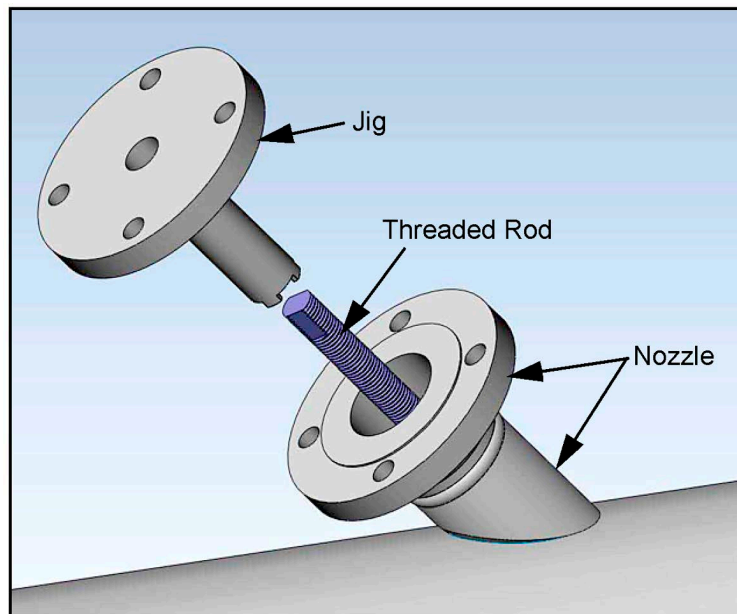
### 1.2.5 Installing the First Nozzle

**IMPORTANT:** Prior to welding the nozzle, it is essential that the nozzle is set up and fixed in position using the jig and the 1-in. threaded rod provided in the kit.

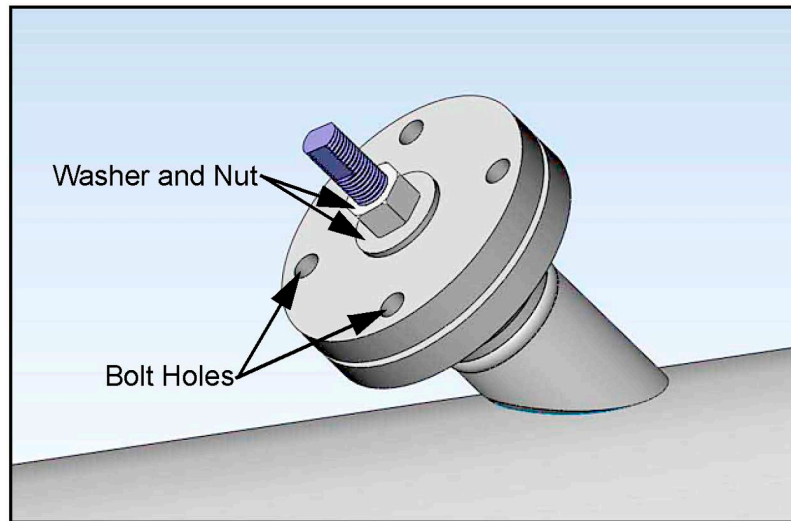
1. Screw the threaded rod into boss that is welded onto the pipe. If necessary, remove the washer and nut from the threaded rod.



2. Slide the nozzle over the threaded rod, and align the contoured end of the nozzle so that it matches the pipe arc. Then slide the jig over the threaded rod and fit the jig into the welding boss.



3. Align the jig bolt holes with the nozzle bolt holes. Then, tighten the assembly together, using the washer and nut on the threaded rod.



4. The jig, boss, and nozzle assembly is designed to provide a 0.094 in. (2.4 mm) root gap between the beveled edge of the nozzle and the outside diameter of the pipe. If this gap is not present all the way around the nozzle, the nozzle must be removed and ground appropriately to provide the required clearance. If the root gap is larger than the 0.094 in. (2.4 mm) dimension evenly all the way around the nozzle, then suitably sized washers may be inserted between the jig and the nozzle to reduce the root gap dimension..

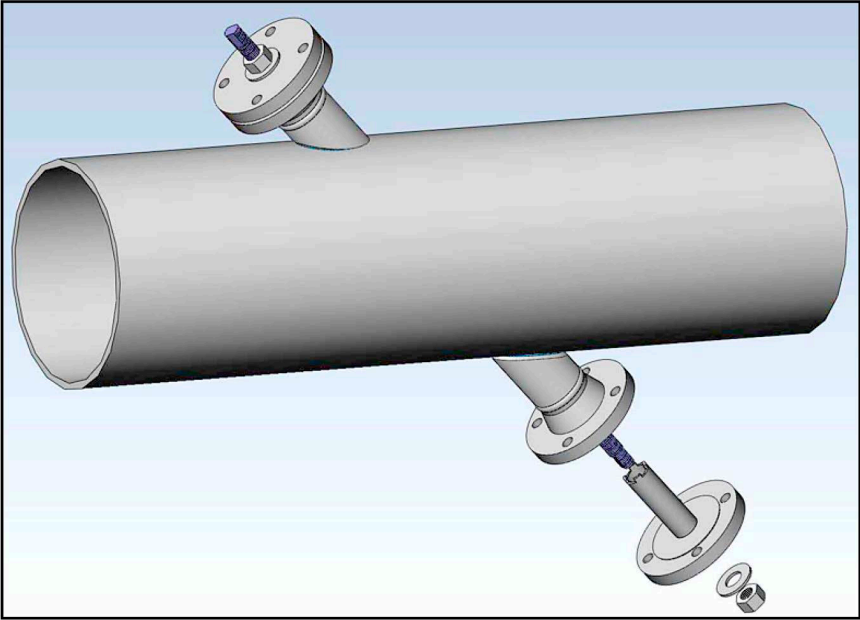


**WARNING!** Only qualified personnel should weld bosses and nozzles, using a suitable ASME IX qualified welding procedure. All applicable safety codes should be observed.

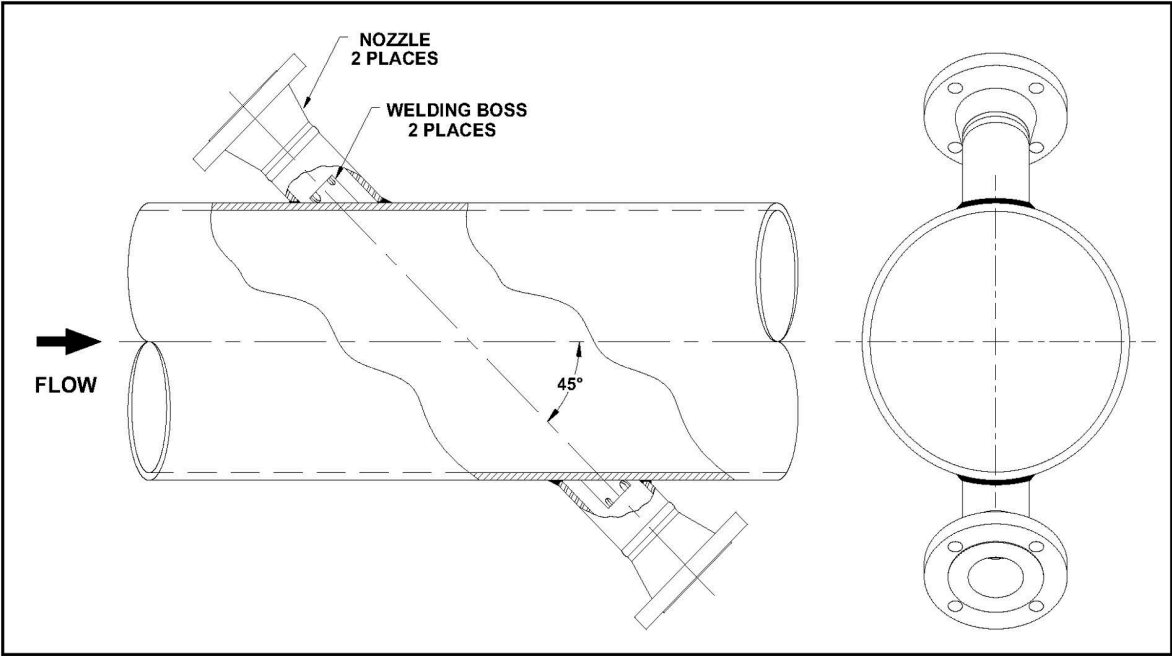
5. Tack weld the nozzle to the pipe at four diametrically opposed points, each tack being approximately 0.6 in. (15 mm) in length. Allow the weld to cool for 30 seconds between tacks.
6. Complete the root pass and subsequent filler passes as required.
7. Allow the weld to cool, and then remove the nut, washer, jig and threaded rod.

### 1.2.6 Installing the Second Welding Boss and Nozzle

Using the same procedures used for installing the first welding boss and nozzle, install the second welding boss and nozzle at the marked position on the pipe.



The completed installation should appear as shown below.



## 1.2.7 Hot Tapping the Pipe

**Note:** Hot tapping a tilted 45° installation is possible only for the standard velocity range (100 m/s, 328 ft/s). For the extended velocity range (120 m/s, 394 ft/s), only the 4" pipe size can be hot topped.



**WARNING!** Hot tapping should only be performed by qualified personnel. Follow all applicable code and safety practices during these procedures.

### 1.2.7.1 Hot Tapping For 3" Flanges

To hot tap the pipe for 3" flanges, complete the following steps:

1. Obtain two suitable 3 in. ANSI flanged isolation valves. The valves should be a full bore type with either 150# RF flanges and a face-to-face length of 8 in. or 300# RF flanges and a face-to-face length of 11.125 in.
2. Install one of the isolation valves, including a suitable gasket, on each of the nozzles. Secure the valves with either 5/8 in. studs and nuts for 150# flanges or 3/4 in. studs and nuts for 300# flanges.
3. Orient the isolation valve handles to minimize interference during operation of the valves.
4. Hot tap holes in the pipe using a hot tap machine equipped with a 3/4 in. (19.05 mm) drill bit.
5. Then use a coupon retaining hole saw to cut a hole with a diameter of 2.36 in. (60 mm) minimum to 2.875 in. (73 mm) maximum.

### 1.2.7.2 Hot Tapping For 2" Flanges

To hot tap the pipe for 2" flanges, complete the following steps:

1. Obtain two suitable 2 in. ANSI flanged isolation valves. The valves should be a full bore type with either 150# RF flanges and a face-to-face length of 7 in. or 300# RF flanges and a face-to-face length of 8.50 in.
2. Install one of the isolation valves, including a suitable gasket, on each of the nozzles. Secure the valves with 5/8 in. studs and nuts.
3. Orient the isolation valve handles to minimize interference during operation of the valves.
4. Hot tap holes in the pipe using a hot tap machine equipped with a 3/4 in. (19.05 mm) drill bit.
5. Then use a coupon retaining hole saw to cut a hole with a diameter of 1.81 in. (46 mm) minimum to 1.89 in. (48 mm) maximum.

## 1.2.8 Cold Tapping the Pipe



**WARNING!** Cold tapping should only be performed by qualified personnel. Follow all applicable code and safety practices during these procedures.

The cold tapping procedure is the same as the hot tapping procedure described above for a standard velocity range (100 m/s, 328 ft/s) installation. Except for the 4 in. pipe size, cold tapping can be performed only before the isolation valve is installed. The hot tap machine is used directly on the nozzles, and the isolation valves are added after the tapping process has been completed.

## Chapter 2. Installing the Isolation Valves

This chapter provides instructions for installing an isolation valve onto a nozzle for applications using the flare gas insertion mechanism.

**Note:** Installation of the isolation valves may have been done already during the hot tapping operation.

### 2.1 Bias 90° Installation (Standard or Extended Velocity Range)

#### 2.1.1 For 3 inch Flanges

1. Obtain two suitable 3 in. ANSI flanged isolation valves. The valves should be a full bore type with either 150# RF flanges and a face-to-face length of 8 in. or 300# RF flanges and a face-to-face length of 11.125 in.
2. Install one of the isolation valves, including a suitable gasket, on each of the nozzles. Secure the valves with either 5/8 in. studs and nuts for 150# flanges or 3/4 in. studs and nuts for 300# flanges.
3. Orient the isolation valve handles to minimize interference during operation of the valves.

#### 2.1.2 For 2 inch Flanges

1. Obtain two suitable 2 in. ANSI flanged isolation valves. The valves should be a full bore type with either 150# RF flanges and a face-to-face length of 7 in. or 300# RF flanges and a face-to-face length of 8.50 in.
2. Install one of the isolation valves, including a suitable gasket, on each of the nozzles. Secure the valves with 5/8 in. studs and nuts.
3. Orient the isolation valve handles to minimize interference during operation of the valves.

### 2.2 Tilted 45° Installation (Standard Velocity Range)

#### 2.2.1 For 3 inch Flanges

1. Obtain two suitable 3 in. ANSI flanged isolation valves. The valves should be a full bore type with either 150# RF flanges and a face-to-face length of 8 in. or 300# RF flanges and a face-to-face length of 11.125 in.
2. Install one of the isolation valves, including a suitable gasket, on each of the nozzles. Secure the valves with either 5/8 in. studs and nuts for 150# flanges or 3/4 in. studs and nuts for 300# flanges.
3. Orient the isolation valve handles to minimize interference during operation of the valves.

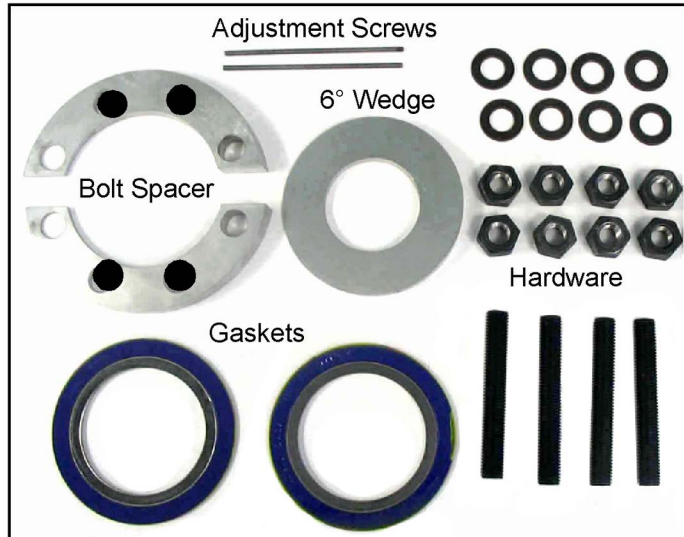
#### 2.2.2 For 2 inch Flanges

1. Obtain two suitable 2 in. ANSI flanged isolation valves. The valves should be a full bore type with either 150# RF flanges and a face-to-face length of 7 in. or 300# RF flanges and a face-to-face length of 8.50 in.
2. Install one of the isolation valves, including a suitable gasket, on each of the nozzles. Secure the valves with 5/8 in. studs and nuts.
3. Orient the isolation valve handles to minimize interference during operation of the valves.

## 2.3 Tilted 45° Installation (Extended Velocity Range)

**Note:** The upstream valve and transducer are installed without wedges, as described in the previous section.

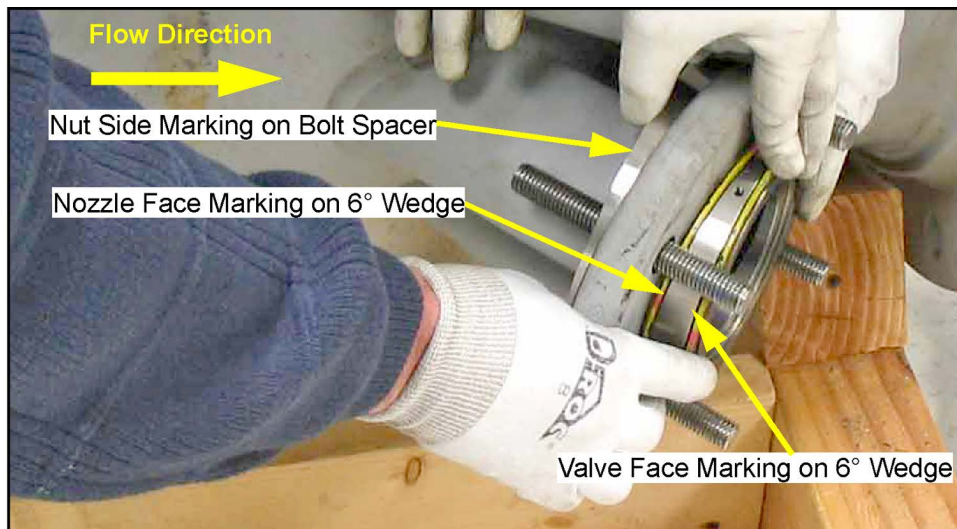
To install the downstream isolation valve, the items shown in Figure 3 below are required.



**Figure 3: Parts for 150# RF Flange Isolation Valve Installation**

1. Insert the four bolts into the nozzle flange holes.
2. With the Nut Side marking facing the pipe, place the split bolt spacer halves over the bolts behind the flange, with the thin ends corresponding to what will be the thickest side of the other wedge (see Figure 4 below).

**Note:** The wedge positions are based on the need to tilt the transducer 6° against the flow.



**Figure 4: Mounting Bolts, Bolt Spacers, Wedge and Gaskets Positions**

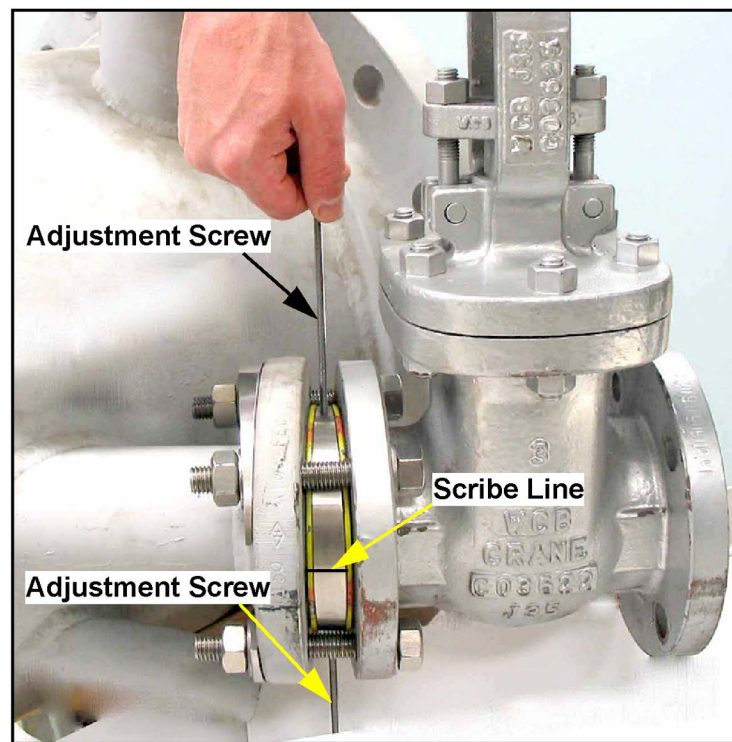


3. With the Nozzle Face marking facing the pipe and the Valve Face marking facing outward, hold the gasket/wedge/gasket combination in line with the insertion hole and oriented as shown in Figure 4 on page 28.
4. While one person holds the gaskets and wedges in place, another person should line up the isolation valve mounting holes with the bolts in the nozzle flange, push the isolation valve against the gasket/wedge/gasket combination, and install the washers and nuts to secure the isolation valve to the nozzle flange (see Figure 5 below).



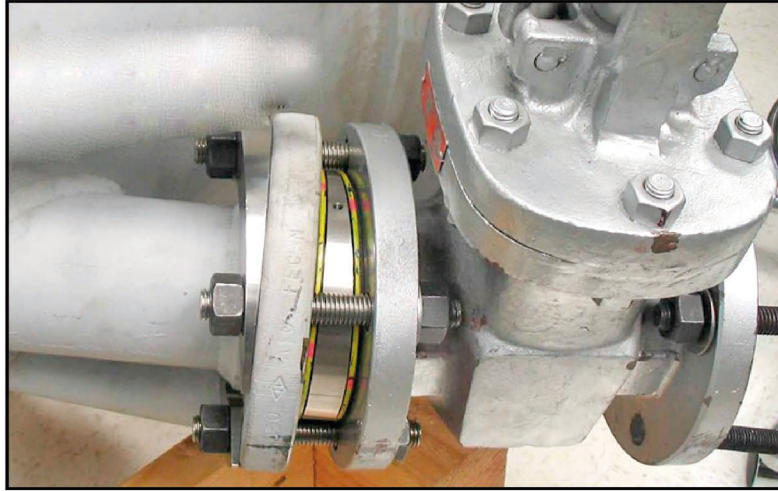
**Figure 5: Mounting the Isolation Valve**

5. Insert the two adjustment screws into the threaded holes on the 6° wedge (see Figure 6 below) and use them to rotate the wedge until the scribe line is centered between the two bolts.



**Figure 6: Adjusting the Wedge Position**

6. After the wedge is positioned correctly, use two wrenches to tighten the hardware and secure the isolation valve to the nozzle. Then remove the adjustment screws from the wedge.



**Figure 7: Completed Isolation Valve Installation**

**Note:** *The upstream valve and transducer are installed without wedges, as described in the previous section.*

## Chapter 3. Installing the Transducer Assemblies

### 3.1 Introduction

Transducers and their holder assemblies are installed into a meter body, which is a section of pipe that contains the ports for mounting the transducer assemblies. The meter body may be prefabricated or created by installing ports on an existing pipe. The transducers can be inserted into the meter body using the following holder methods:

- Low-pressure insertion mechanism
- Barrel holder
- Flanged holder

**Note:** As an example, this chapter describes the use of the low-pressure insertion mechanism type only.

### 3.2 Using the Low-Pressure Insertion Mechanism

**Note:** The Low-Pressure Insertion Mechanism is designed for manual (non-assisted) transducer insertion into operating pipes at low pressure. The mechanism uses an isolation valve and a packing gland for sealing.

Inserting the transducers into the pipe requires the following steps:

- Preparing for installation
- Mounting the insertion mechanism
- Inserting the transducer into the pipe
- Aligning the transducers



**WARNING!** The manual insertion mechanism is used for low-pressure applications (80 psig/6.5 bar absolute or less). Use the appropriate safety precautions when inserting or withdrawing the insertion mechanism.

#### 3.2.1 Preparing for Installation

Before you begin, find a work area where you can stand the insertion mechanism upright without placing any weight on the transducer (e.g., a bench with a cutout large enough for the transducer to slide through).

You will need the following items for installation:

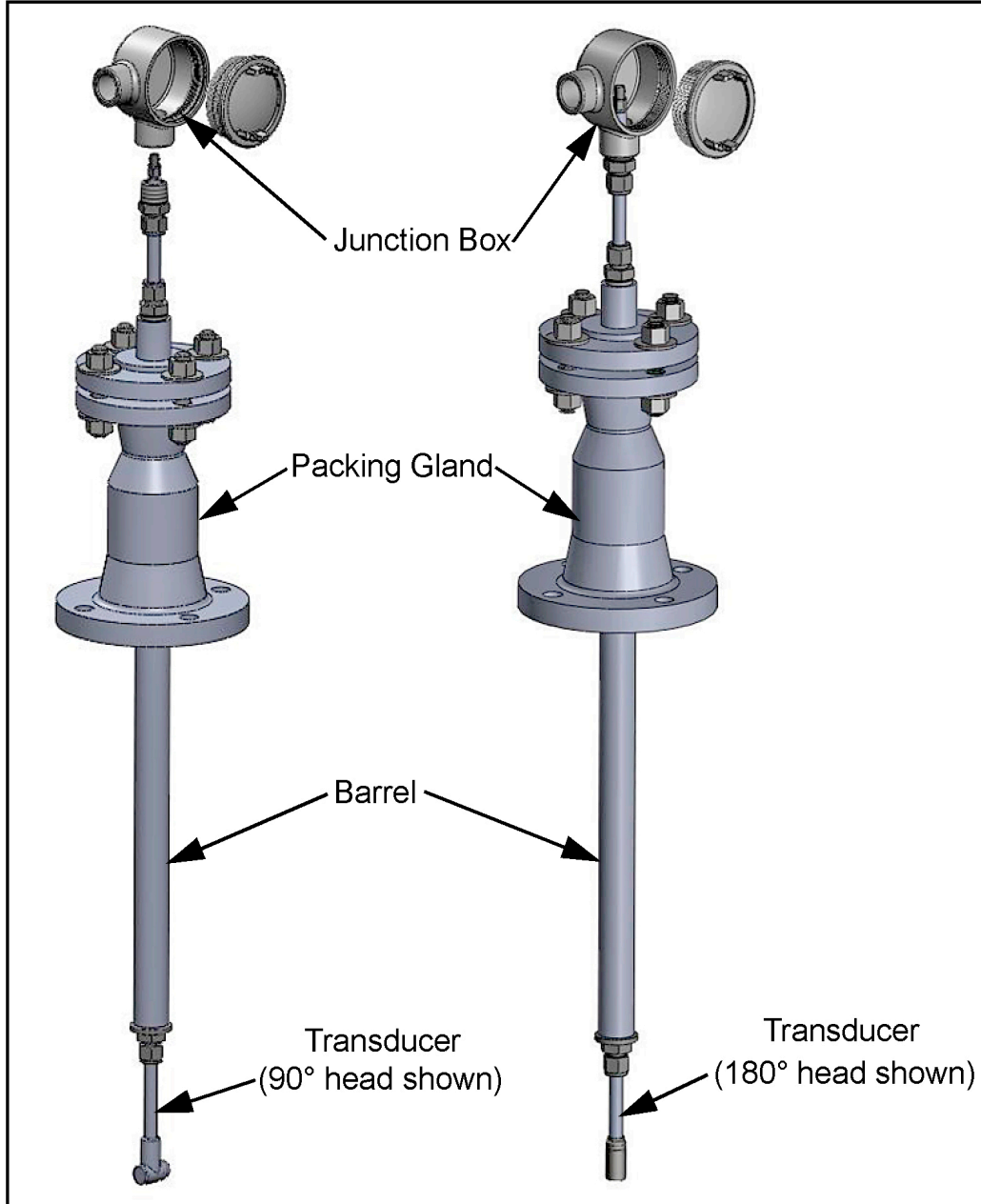
- A packing tool (may be shipped with the flowmeter)
- A gasket for the isolation valve
- A straight edge ruler
- A tag to place on the isolation valve
- Bolts

#### 3.2.2 Mounting the Insertion Mechanism

1. Before mounting the insertion mechanism on the isolation valve you should familiarize yourself with its components (see the figure below):

- Junction box
- Barrel
- Packing gland
- Transducer

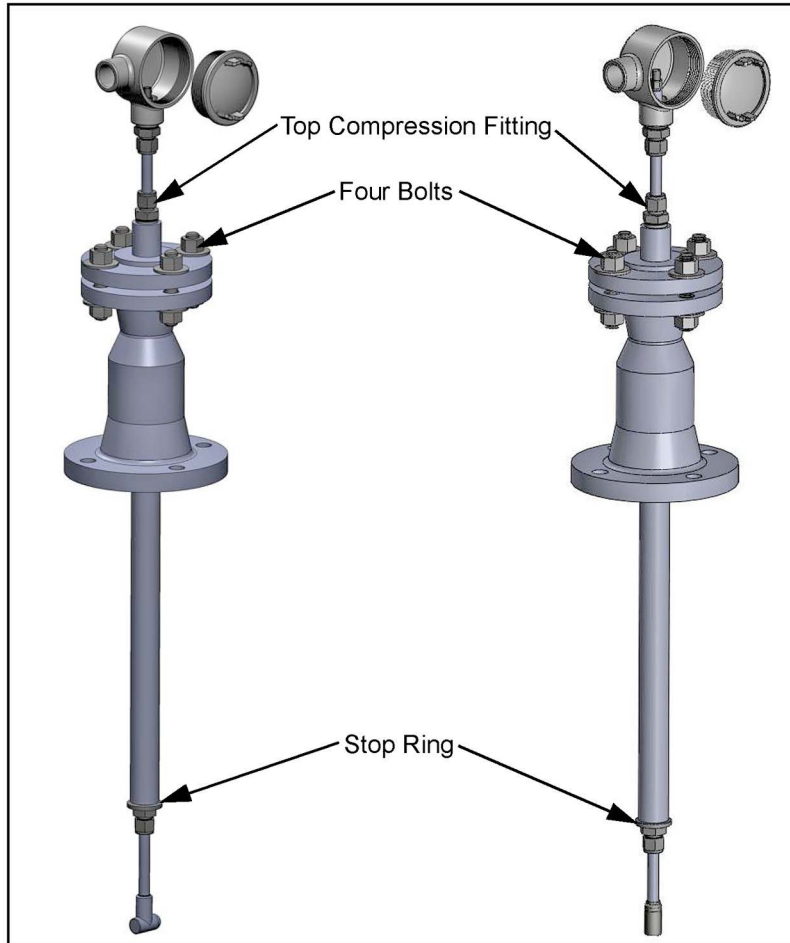
**Note:** Explosion-proof junction boxes are not pre-mounted on the end of the transducer when shipped.



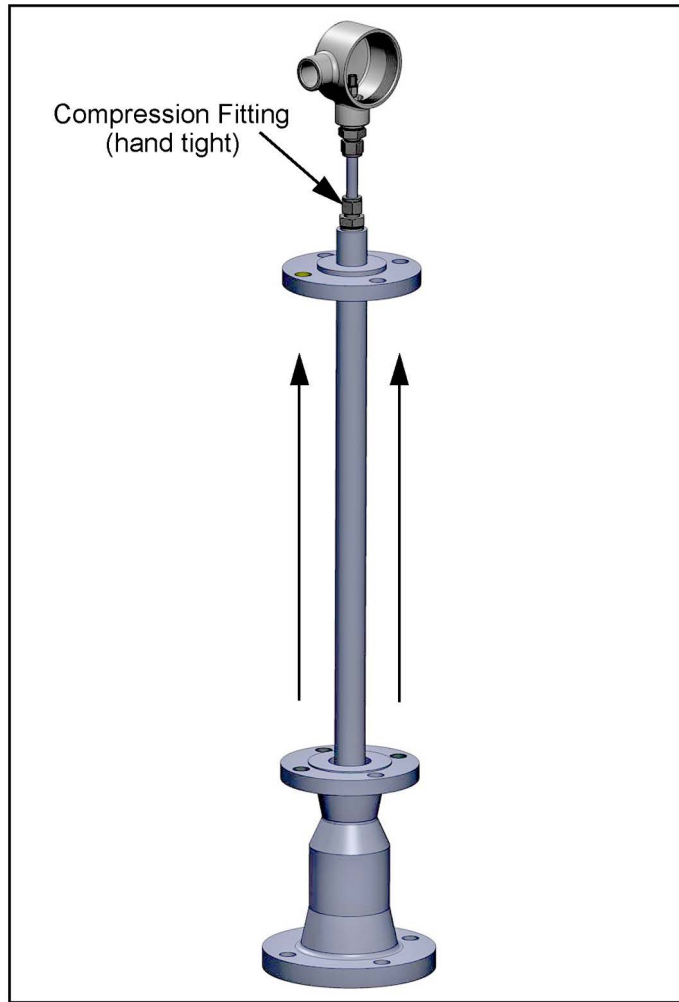
2. Visually inspect the transducer, and make sure the top compression fitting is not loose.

**IMPORTANT:** The stop ring at the end of the barrel should be loose. DO NOT tighten the compression fitting or you could change the transducer alignment.

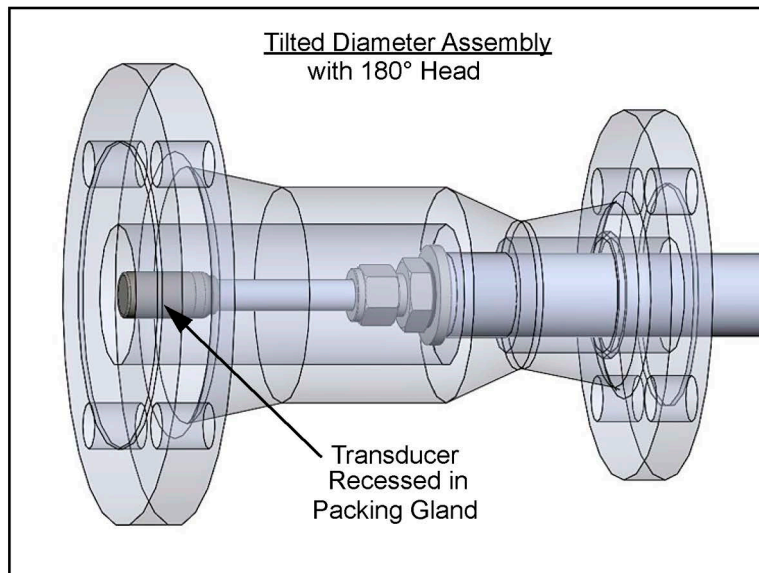
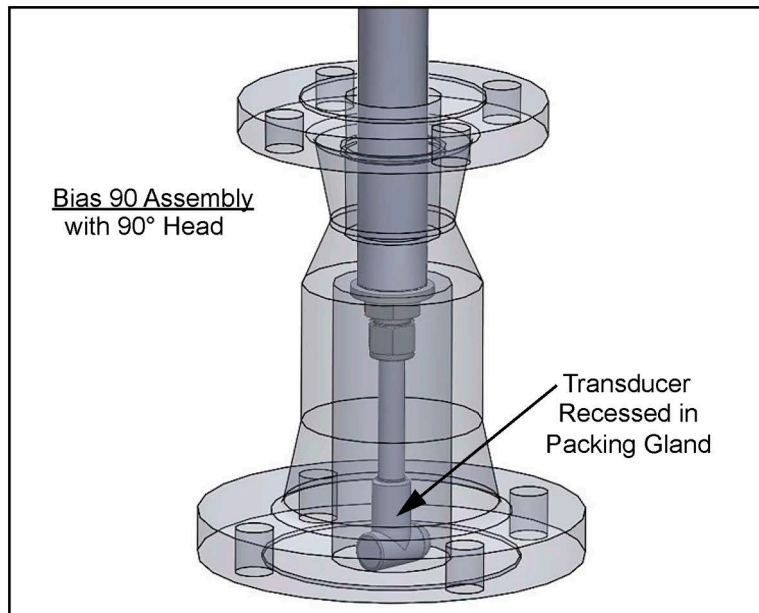
3. Remove the four bolts that fasten the barrel to the packing gland.



4. Retract the barrel from the packing gland so that the transducer head is recessed in the packing gland. You will hear the stop ring click into place when the transducer is fully recessed.



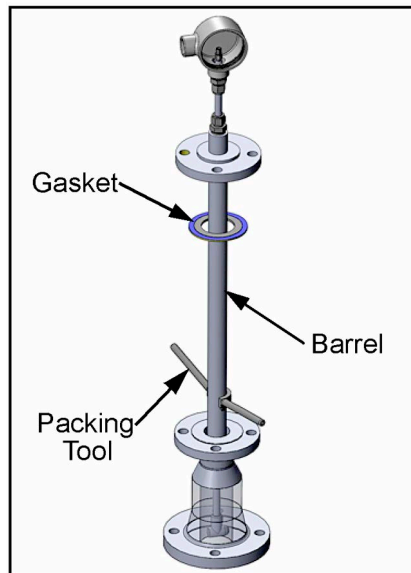
5. Visually inspect the mechanism. Make sure the transducer is recessed in the packing gland. Again, make sure the top compression fitting is secure and hand tight.



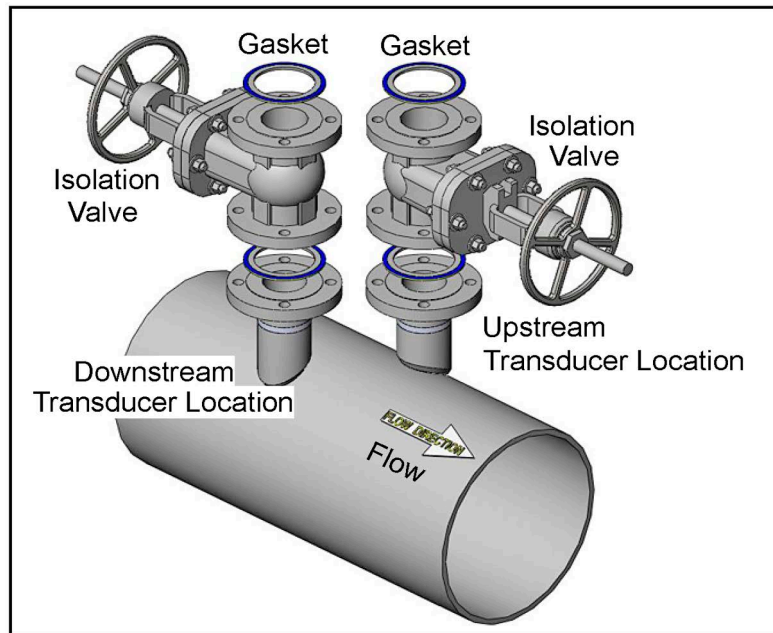


### 3.3 Mounting the Bias 90 Insertion Mechanism/Transducer Assembly

1. Lift the gasket and insert the packing tool into the packing nut. By turning the packing tool clockwise, tighten the packing material so that the barrel stays up without support.

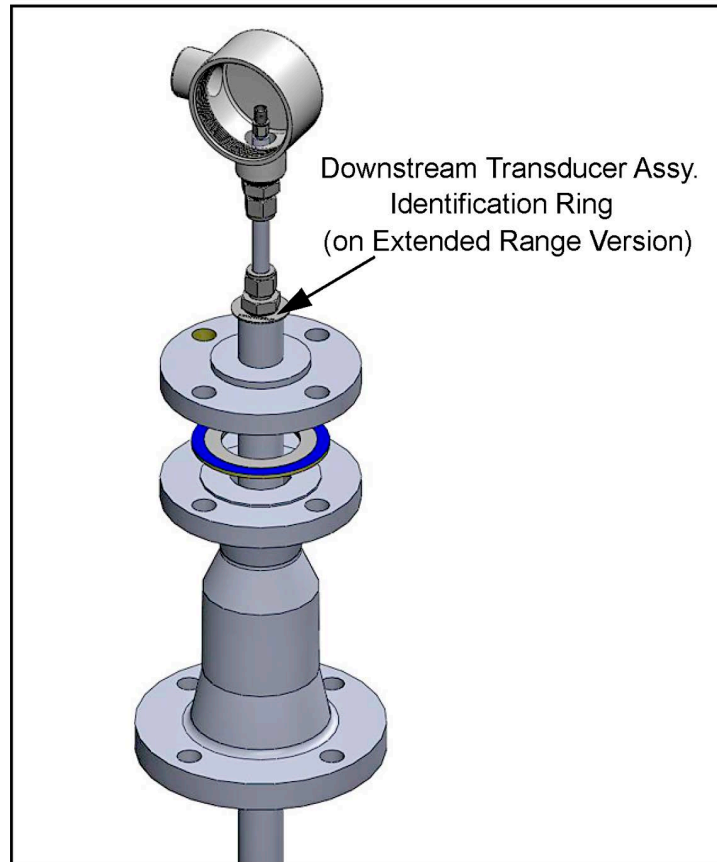


2. Verify that the isolation valves are securely installed with gaskets and hardware. Then, place a gasket on the face of each isolation valve.

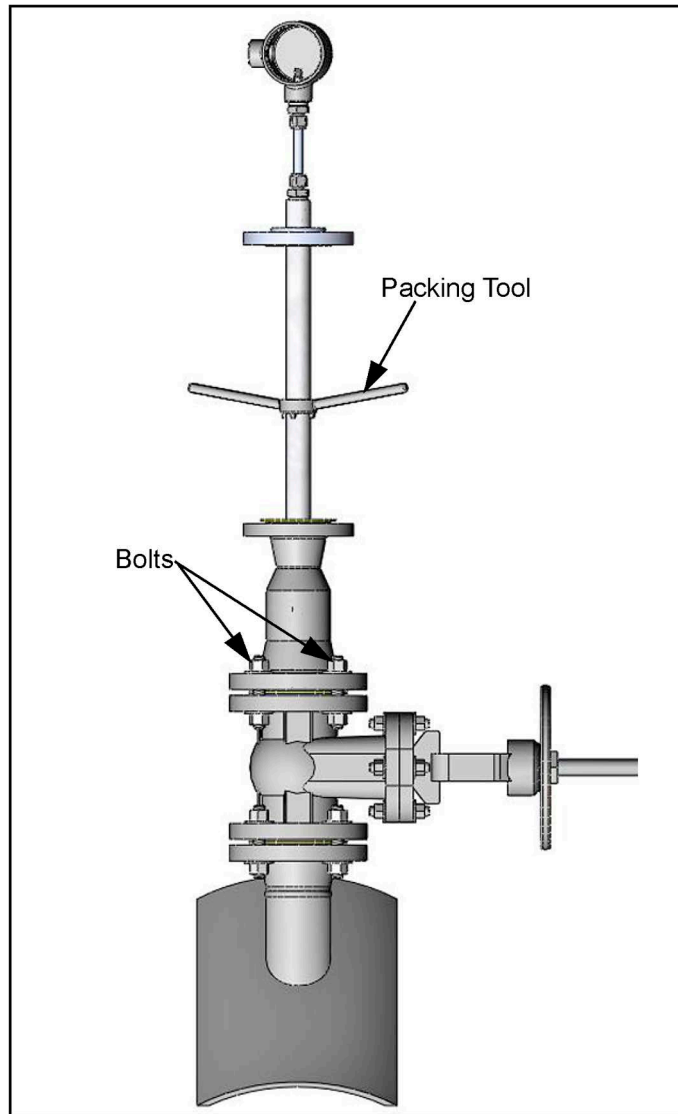




3. Identify the upstream and downstream nozzles as follows:
  - For a Standard Velocity Range application, the upstream and downstream nozzles are interchangeable, because the system is bi-directional.
  - For an Extended Velocity Range application, the system is not bi-directional. Note which nozzle is designated as upstream and which is designated as downstream on the pipe. Then, identify the upstream and downstream insertion mechanism assemblies. The downstream assembly is labeled with a ring marked Downstream at the end of the assembly near the junction box (see the figure below).
4. Proceed with either the upstream or downstream assembly.
5. Lift the insertion mechanism by the barrel and place the insertion mechanism on the isolation valve.



6. Line up the flange holes and bolt the packing gland to the isolation valve.



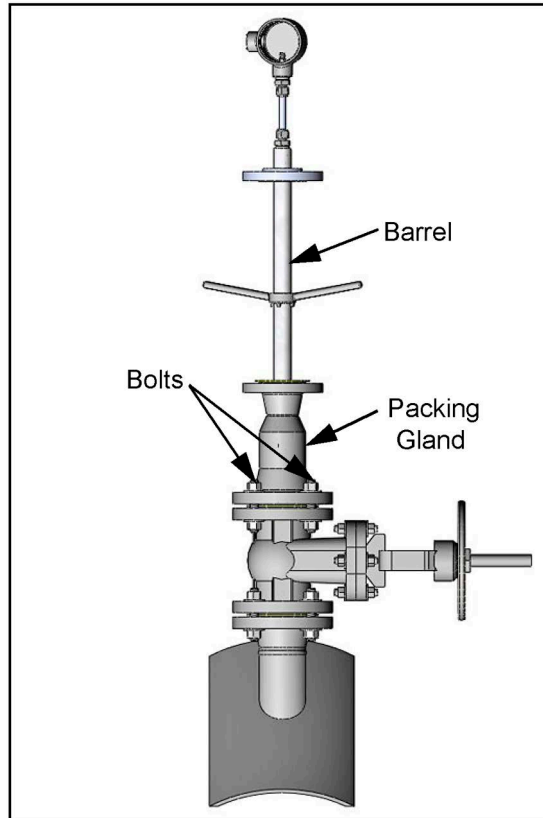
7. Using the packing tool, tighten the packing nut again so the nut is recessed.



**WARNING!** The packing material must be securely packed before the isolation valve is opened.

### 3.4 Inserting the Bias 90 Transducer into the Pipe

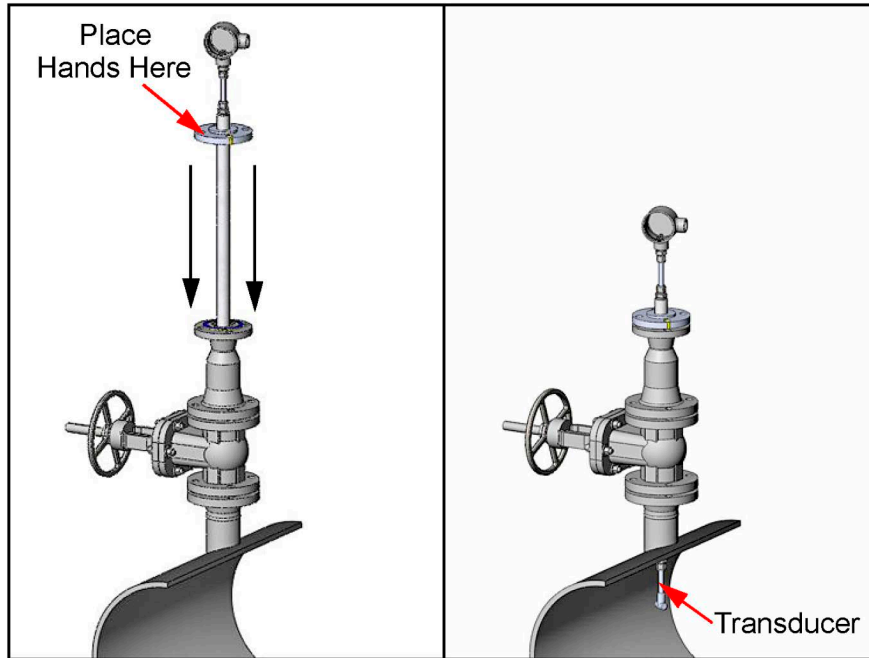
1. Before you open the isolation valve, carefully verify the following:
  - The barrel is pulled up as far as it can go
  - All bolts are secure
  - The transducer head is recessed in the packing gland



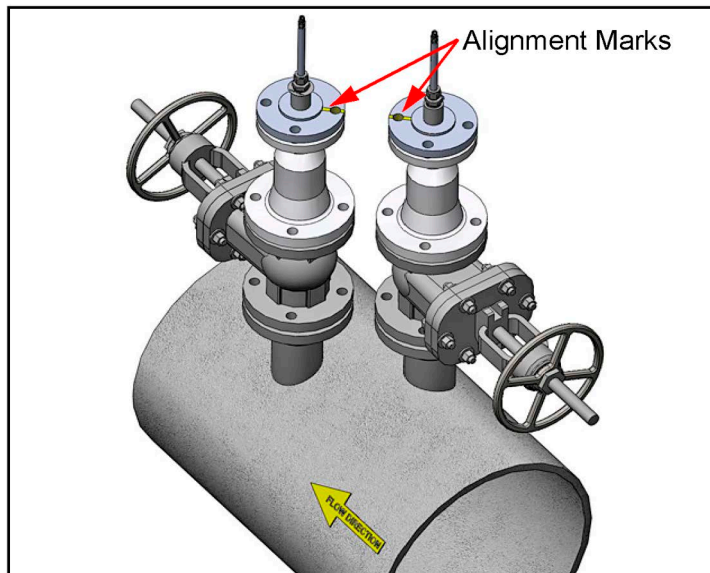
**WARNING!** Follow all applicable safety codes and practices before opening the isolation valve.

2. Open the isolation valve.

3. Placing your hands on top of the barrel, push the barrel/transducer down into the pipe so that the barrel flange and the packing gland flange meet. You may have to twist the barrel to get it moving.

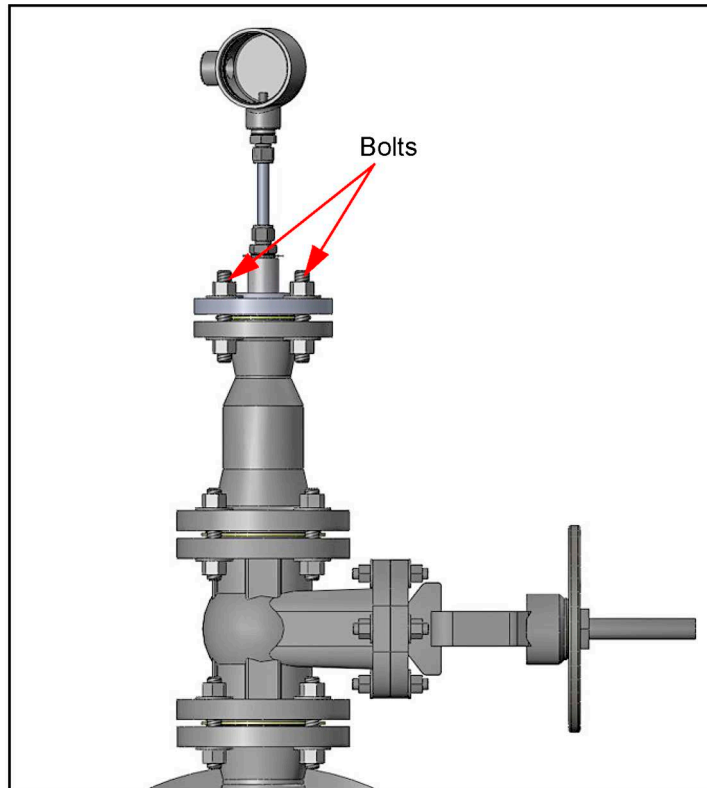


4. For this Bias 90 configuration, orient the alignment marks on each barrel flange so that they are facing each other. The alignment mark, which is marked with yellow paint, is scribed on the top and outside of the flange.



5. Place two bolts into the flange in holes opposite each other, but not in the hole with the scribe mark. Then, hand tighten the nuts.

**Note:** **DO NOT** insert the remaining bolts until instructed to do so in the following section.



6. Install the second insertion mechanism by repeating the steps in the two previous sections. After the second insertion mechanism is installed, proceed to one of the following sections:
  - “Aligning the Transducers (Standard Velocity Range)” on page 42
  - “Aligning the Transducers (Extended Velocity Range)” on page 42

### 3.5 Aligning the Transducers (Standard Velocity Range)

For applications with gas flow velocities up to 100 m/s, align the transducers as follows:

**Note:** These instructions apply to both the upstream and downstream transducer assemblies.

1. Use a straight edge to line up the alignment marks on the two barrel flanges.
2. Place the remaining bolts into the flanges and tighten them securely.
3. Place a tag on each isolation valve stating the following:

**DO NOT OPERATE (CLOSE) WHEN  
TRANSDUCER IS INSERTED INTO PIPE.**

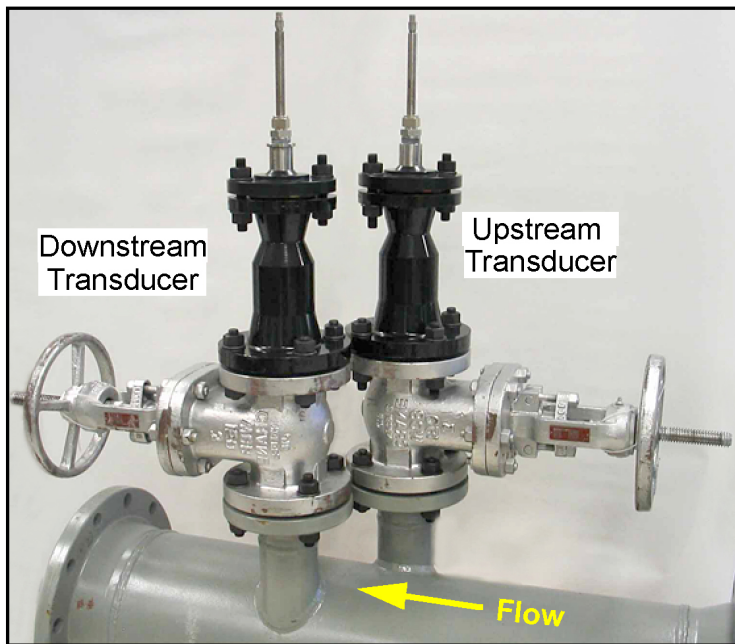
4. Refer to your flowmeter Startup Guide to make the transducer electrical connections.

### 3.6 Aligning the Transducers (Extended Velocity Range)

For applications with gas flow velocities up to 120 m/s, align the transducers as follows:

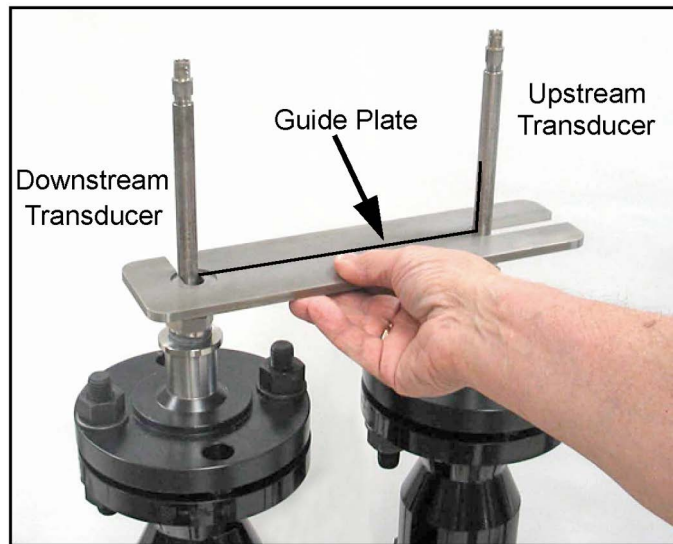
**Note:** The downstream transducer is pre-installed at the factory in the barrel of the downstream insertion mechanism, to shift the signal direction 6° away from the upstream transducer signal.

1. Verify that the downstream transducer is located on the right to a person looking from the downstream end of the pipe (see Figure 8 below). Contact Panametrics if the port locations do not follow this convention.



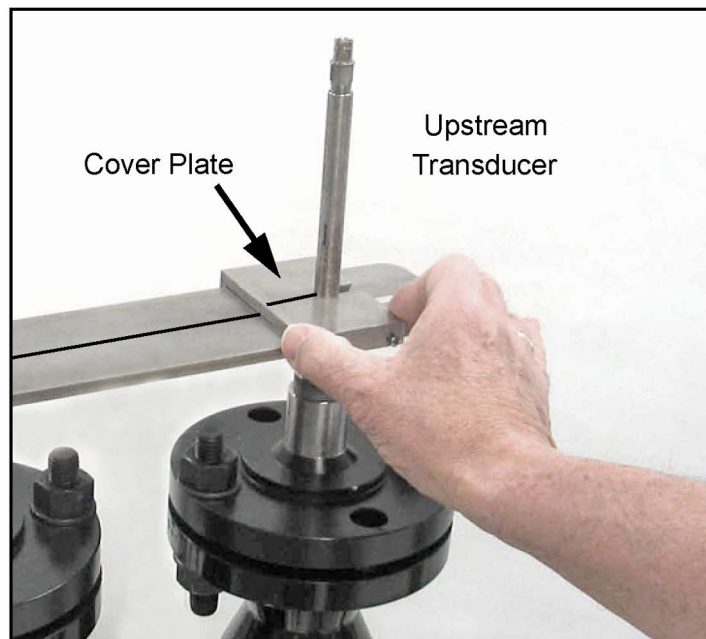
**Figure 8: Extended Range Transducer Installation**

- Slide the end slot of the guide plate around the upstream transducer, and rotate the plate until the side slot is around the downstream transducer (see Figure 9 below). Then, align the mark on the upstream transducer barrel with the guide plate mark. Slightly tighten the upstream barrel flange bolts to maintain the alignment.



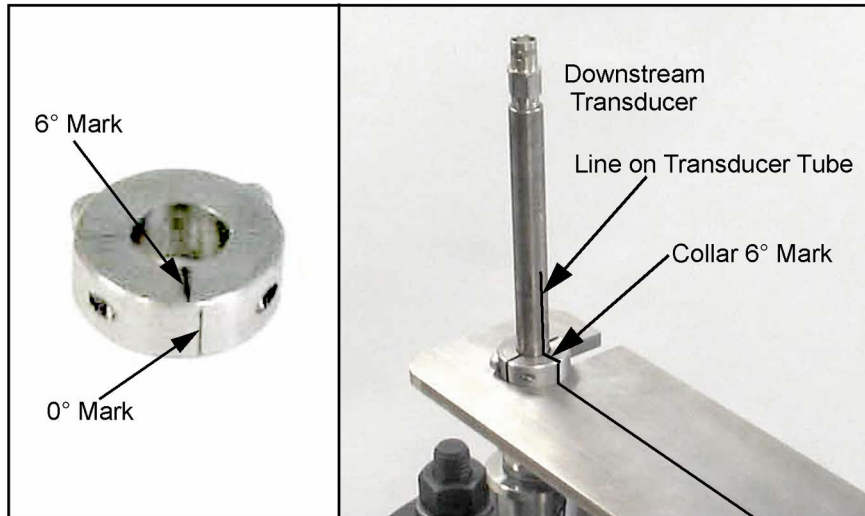
**Figure 9: Installing the Guide Plate**

- Place the cover plate on top of the guide plate and slide it as far as possible until it is positioned around the upstream transducer, as shown in Figure 10 below. Then, tighten the screws to secure it.



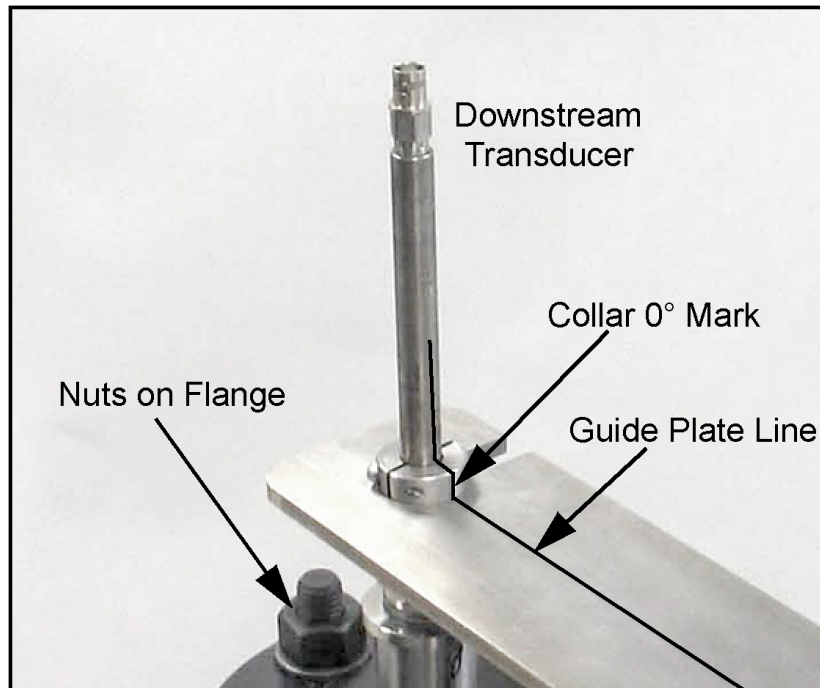
**Figure 10: Installing the Cover Plate**

- Slide the locking collar over the downstream transducer to the cavity on top of the guide plate. Align the 6° mark on the top of the collar with the line on the transducer (see Figure 11 below). Then, tighten the collar set screws until the collar is secured to the transducer.



**Figure 11: Installing the Locking Collar**

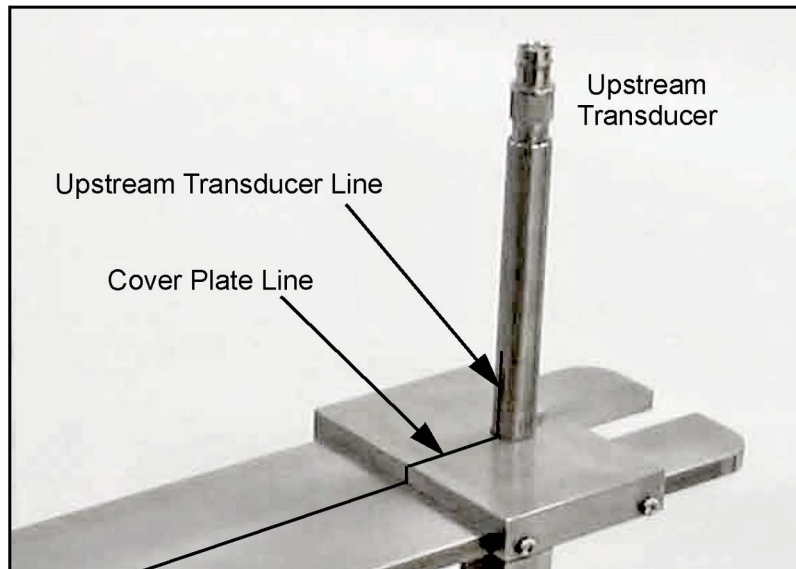
- Check to see if the 0° mark on the side of the locking collar is aligned with the line on the guide plate. If they are not aligned, then loosen the nuts on top of the barrel flange and rotate the transducer assembly until the two lines are aligned (see Figure 12 below). Then, re-tighten the nuts.



**Figure 12: Locking Collar 0° Mark Aligned with Guide Plate Line**



6. Check to see if the line on the upstream transducer tube is aligned with the line on the cover plate. If they are not aligned, loosen the nuts on top of the barrel flange and rotate the transducer assembly until the two lines are aligned (see Figure 13 below). Then, re-tighten the nuts.

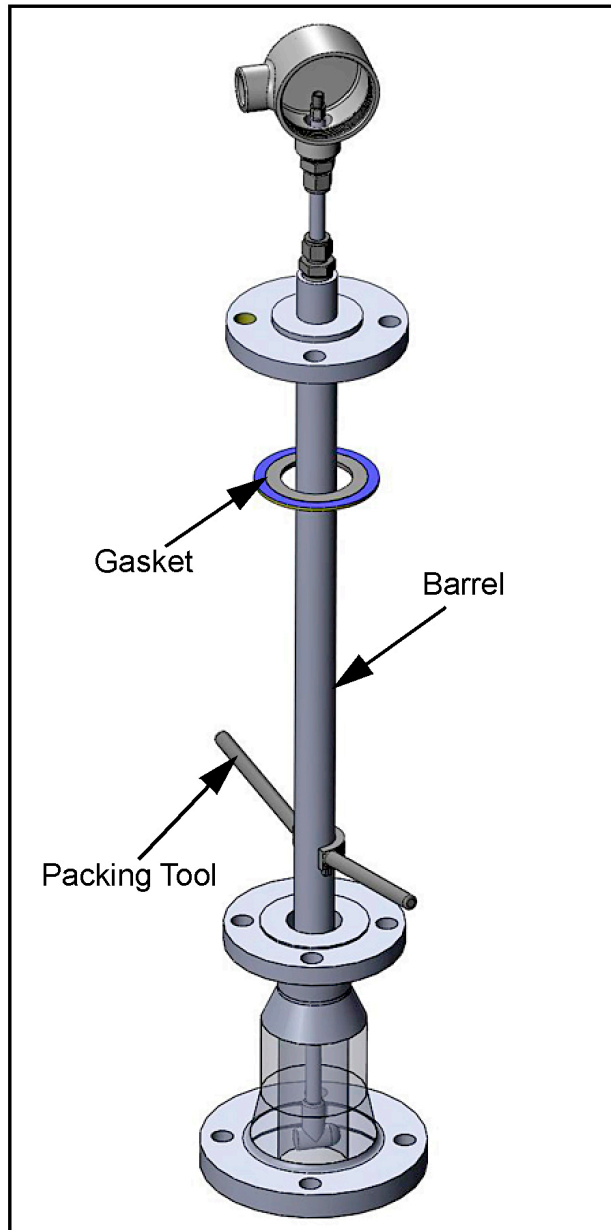


**Figure 13: Upstream Transducer Mark Aligned with Cover Plate Line**

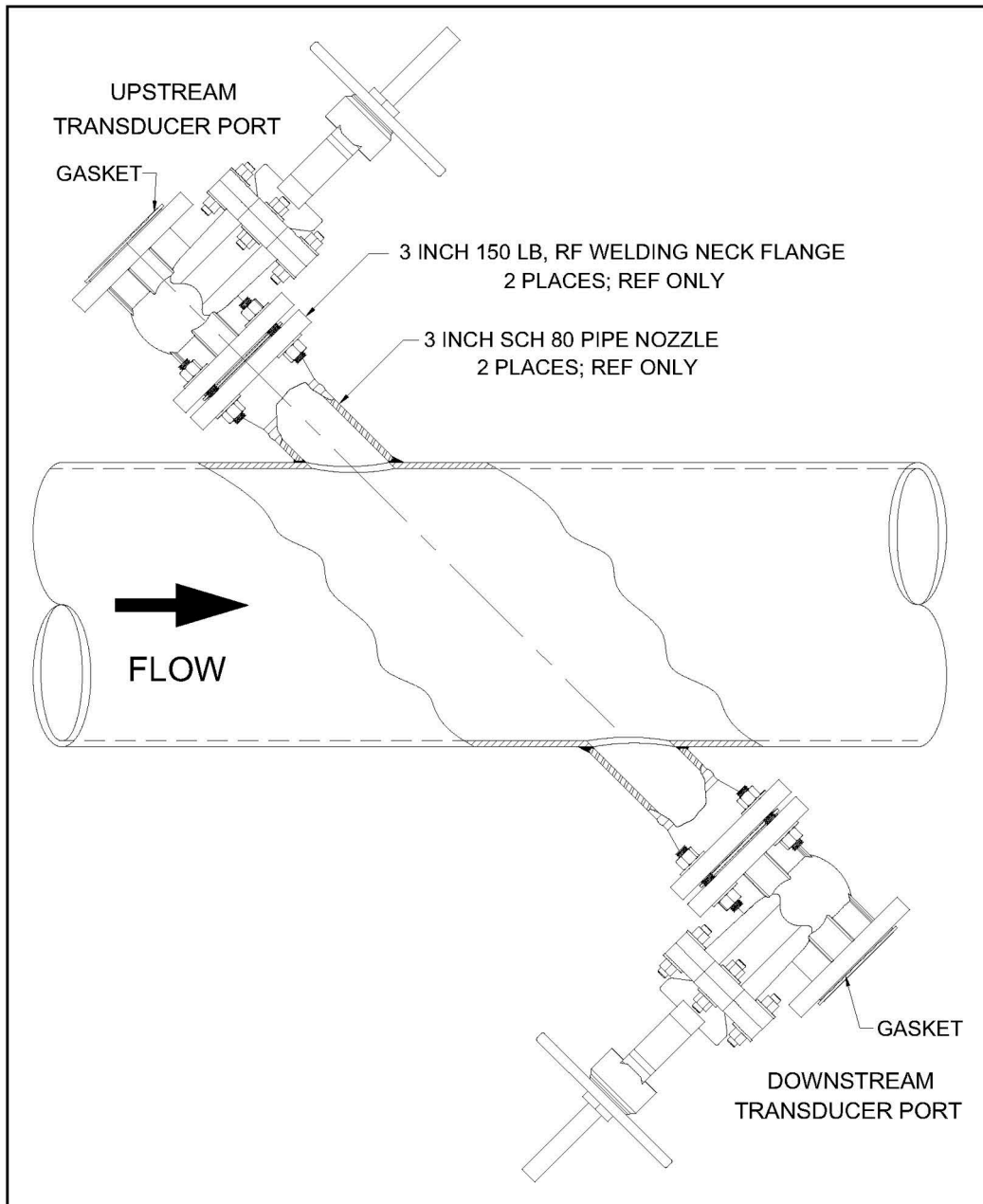
7. Upon completion of the above steps, remove the cover plate, locking collar and guide plate from the transducer assemblies.
8. Place the remaining bolts into the flanges and tighten them securely.
9. Place a tag on each isolation valve stating the following:  
**DO NOT OPERATE (CLOSE) WHEN  
TRANSDUCER IS INSERTED INTO PIPE.**
10. Refer to your flowmeter Startup Guide to make the transducer electrical connections.

### 3.7 Mounting the Tilted 45 Insertion Mechanism/Transducer Assembly

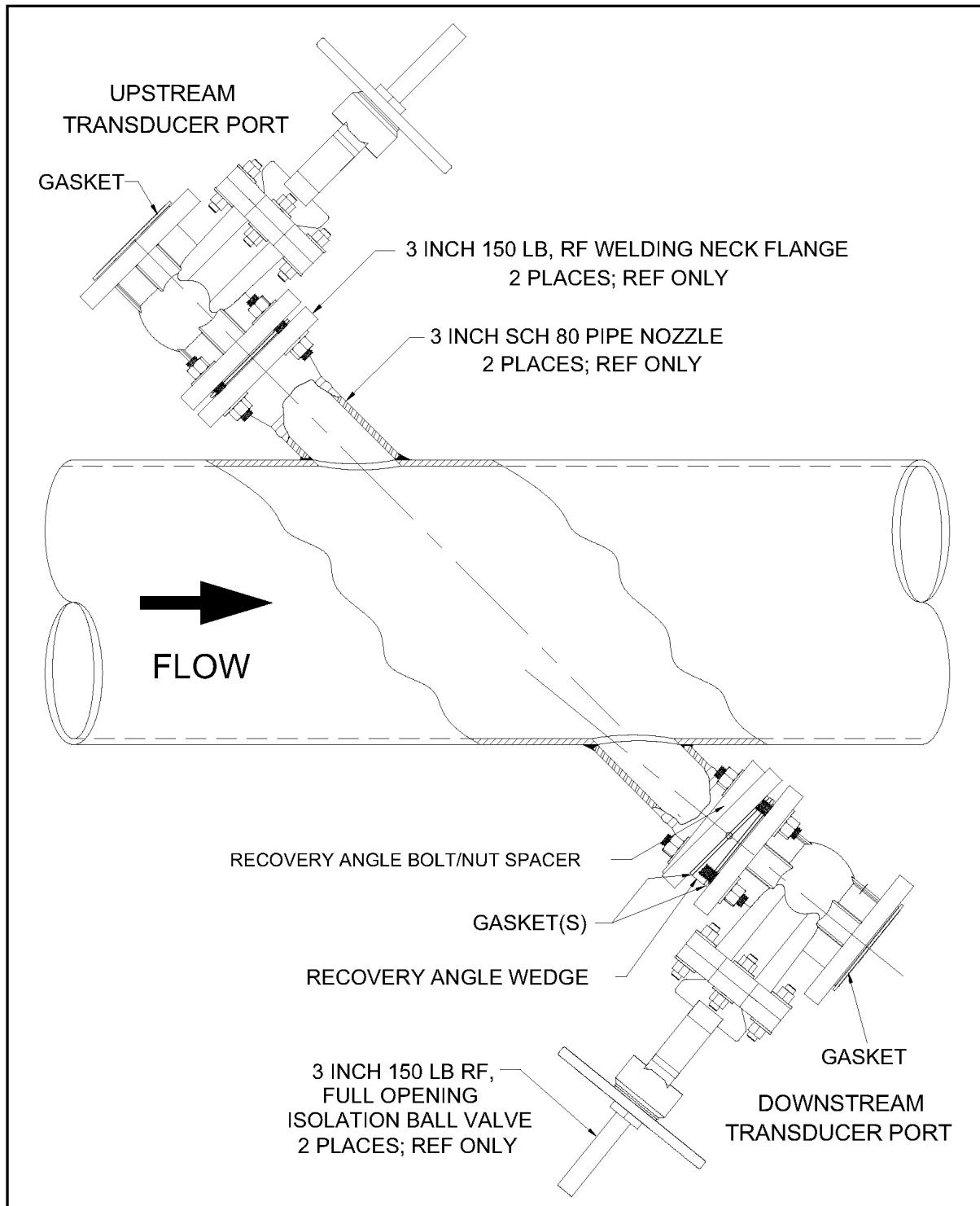
1. Lift the gasket and insert the packing tool into the packing nut. Turning the packing tool clockwise, tighten the packing material so that the barrel will stay up without support.



2. Check and make sure the isolation valves are securely installed with gaskets and hardware. Then, place a gasket on the face of each isolation valve (see either Figure 14 below or Figure 15 on page 48).

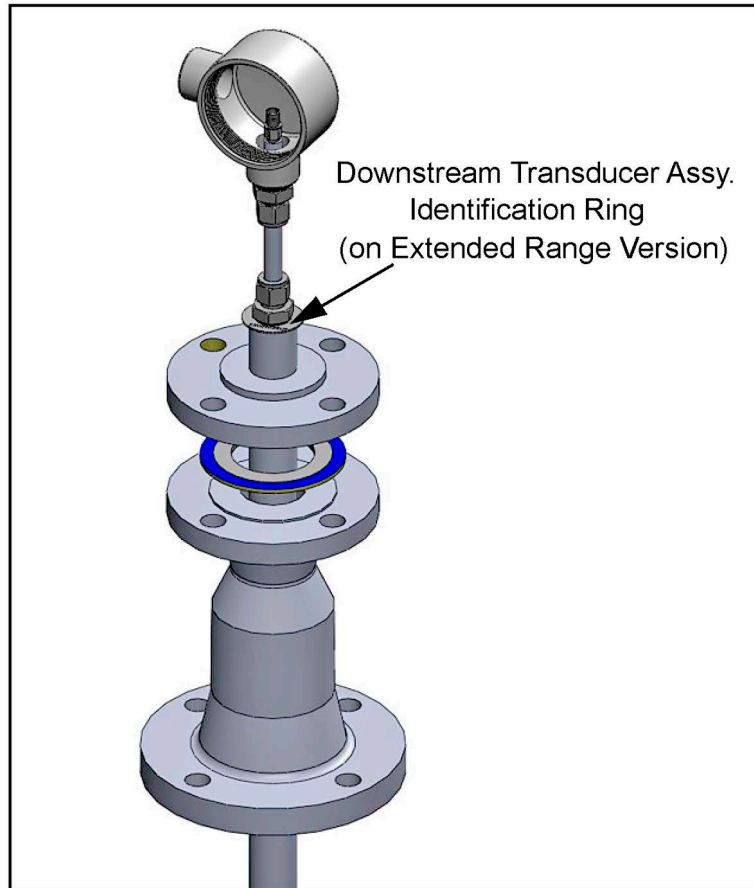


**Figure 14: Standard Velocity Range Assembly**

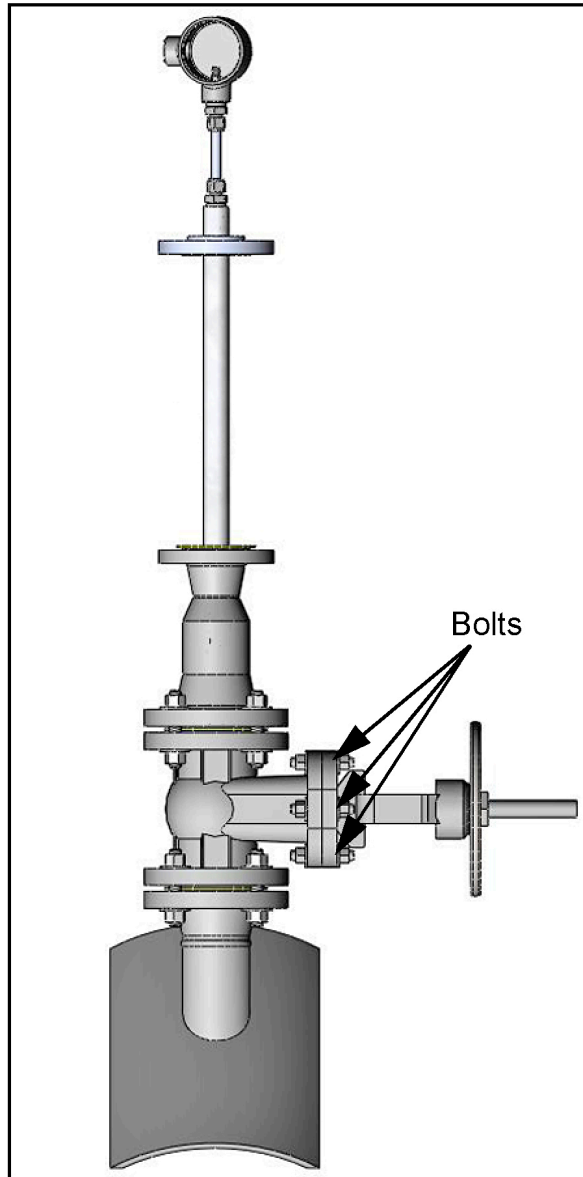


**Figure 15: Extended Velocity Range Assembly**

3. Identify the upstream and downstream nozzles as follows:
  - For a Standard Velocity Range application, the upstream and downstream nozzles are interchangeable, because the system is bi-directional.
  - For an Extended Velocity Range application, the system is not bi-directional. Note which nozzle is designated as upstream and which is designated as downstream on the pipe. Then, identify the upstream and downstream insertion mechanism assemblies. The downstream assembly is labeled with a ring marked Downstream at the end of the assembly near the junction box (see the figure below).
4. Proceed with either the upstream or downstream assembly.
5. Lift the insertion mechanism by the barrel and place the insertion mechanism on the isolation valve.



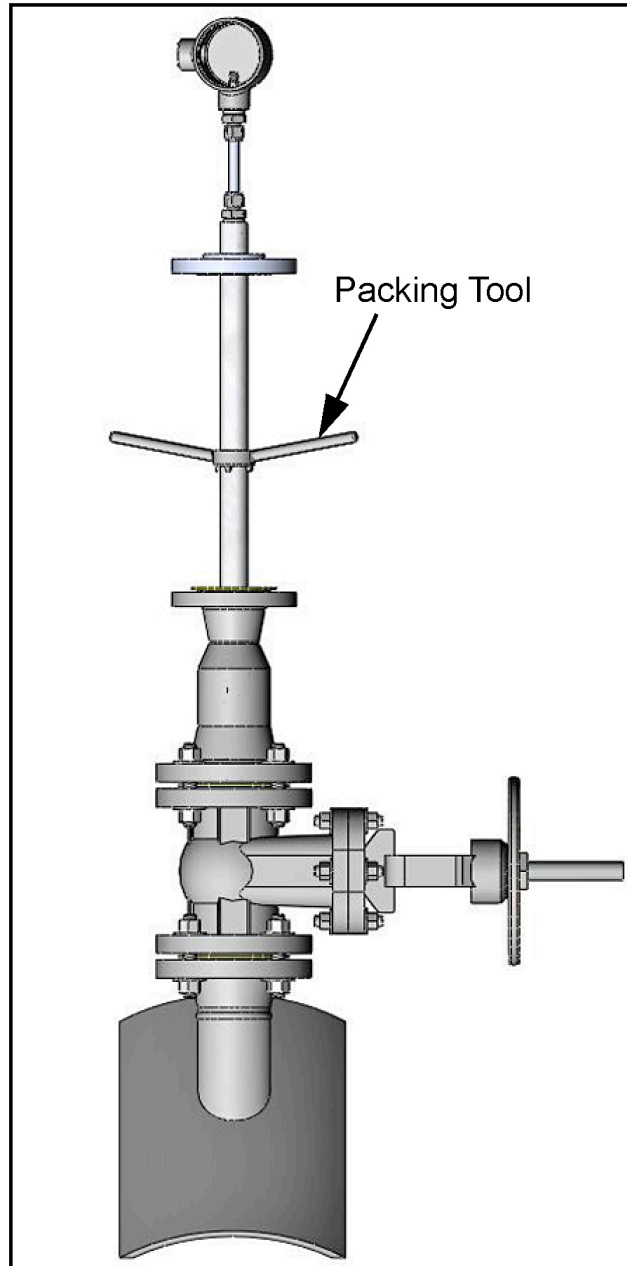
6. Line up the flange holes and bolt the packing gland to the isolation valve.



- Using the packing tool, tighten the packing nut again until the nut is recessed.

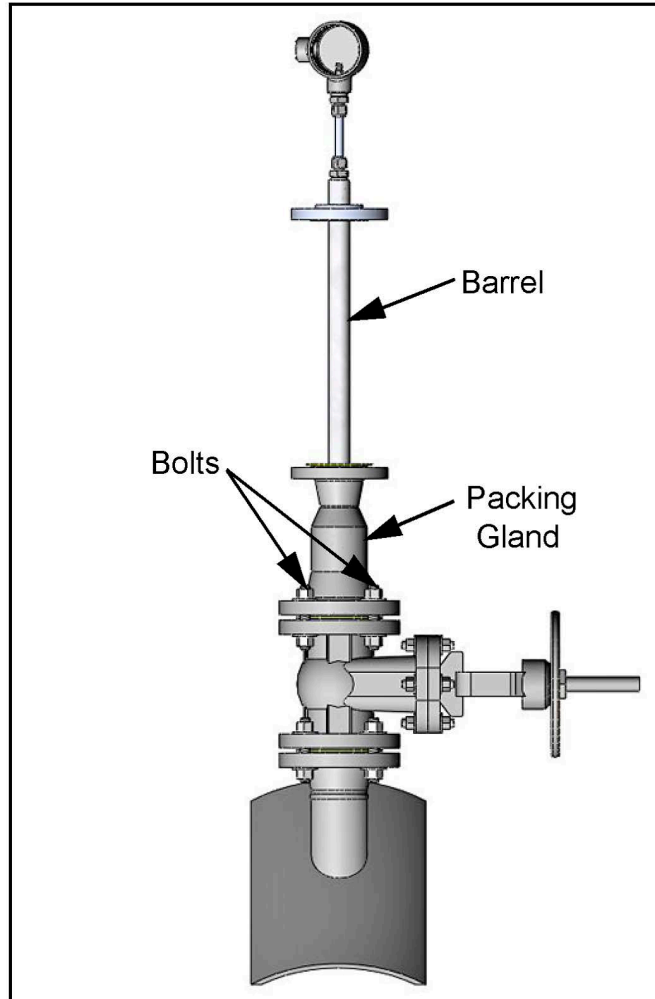


**WARNING!** The packing material must be securely packed before the isolation valve is opened.



### 3.8 Inserting the Tilted 45 Transducer into the Pipe

1. Before you open the isolation valve, carefully verify the following:
  - The barrel is pulled up as far as it can go
  - All bolts are secure
  - The transducer head is recessed in the packing gland.

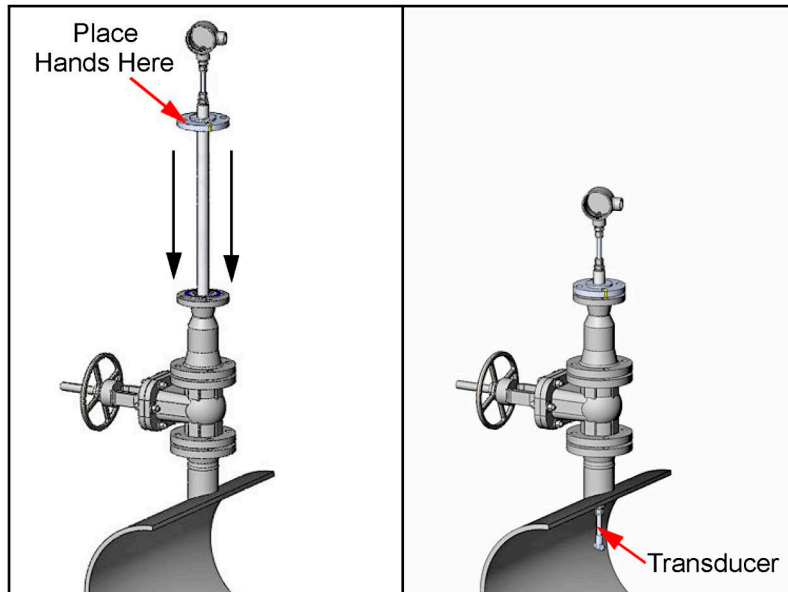


**WARNING!** Follow all applicable safety codes and practices before opening the isolation valve.

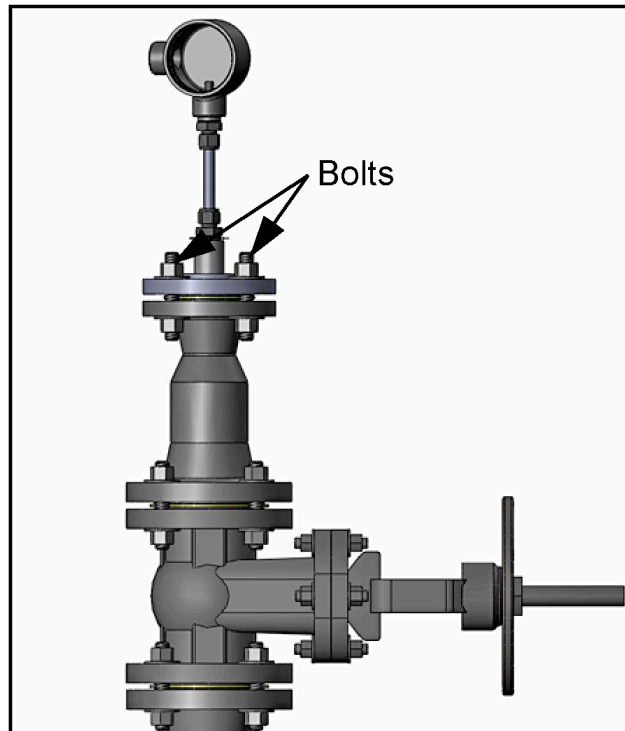
2. Open the isolation valve.



3. Placing your hands on top of the barrel, push the barrel/transducer down into the pipe so that the barrel flange and the packing gland flange meet. You may have to twist the barrel to get it moving.



4. Place the bolts into the flange joining the barrel flange to the packing gland flange.
5. 5. Tighten the bolts securely.



6. Install the second insertion mechanism by repeating the steps in the previous sections. Confirm that the downstream transducer assembly is in the downstream port and the upstream transducer assembly is in the upstream port.

**Note:** The following steps apply to both the upstream and downstream assemblies equally.

7. Place a tag on each isolation valve stating the following:

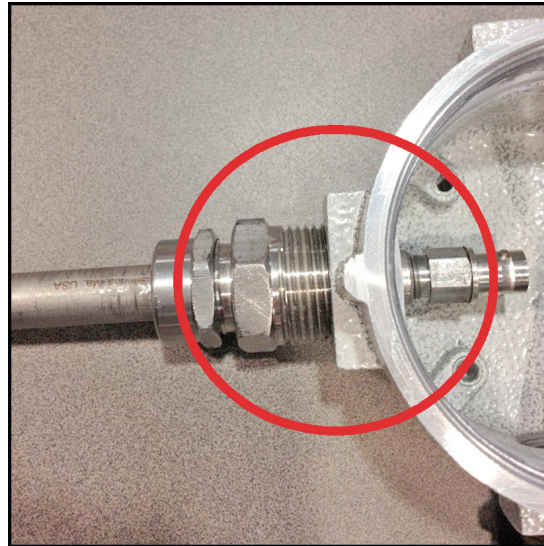
**DO NOT OPERATE (CLOSE) WHEN  
TRANSDUCER IS INSERTED INTO PIPE**

8. Refer to your flowmeter Startup Guide to make the transducer electrical connections.

### 3.9 Connecting an XAMP

This section explains how to correctly install and assemble an XAMP into a transducer junction box. It applies to all three possible junction box options, but only one of the junction box options is used as an example in the steps below.

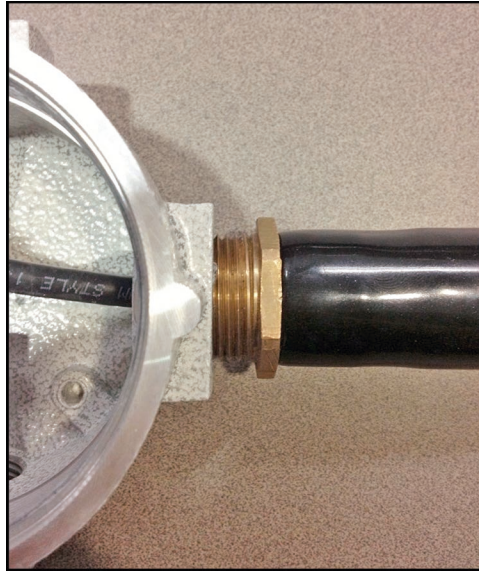
1. Place a 3/4" NPT compression fitting on the stem of the transducer closest to the BNC connector.
2. Torque the fitting into one of the 3/4" NPT ports of the junction box with at least 5 threads engaged. After the fitting is torqued into place, ensure that the BNC head of the transducer extends slightly past the ground screw bosses, as shown in Figure 16 below::



**Figure 16: Torquing the NPT Reducer**

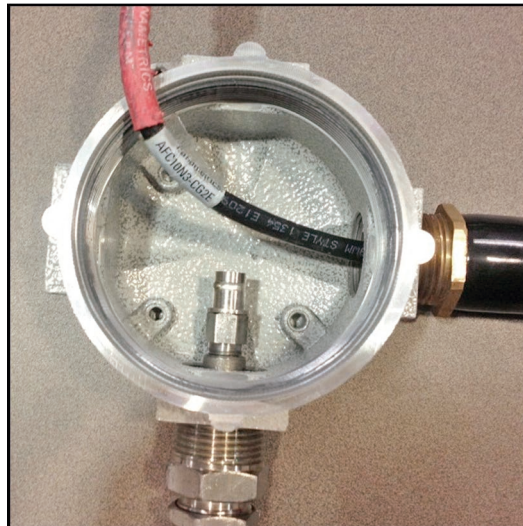
3. If the BNC head extends too far into the junction box, it will make the assembly more difficult to install by reducing the amount of area needed to properly store the excess cable. If the BNC head is not positioned approximately where it is pictured in Figure 16 above, loosen the compression fitting and adjust the transducer. Then, re-tighten the compression fitting.

4. Torque the cable gland coming from the flowmeter electronics main housing into the other 3/4" NPT port in the junction box until there are at least 5 threads of engagement (see Figure 17 below).



**Figure 17: Torquing the Cable Gland**

5. Verify that, with the transducer and the cable gland assembled, the junction box looks like Figure 18 below:



**Figure 18: Assembled Transducer and Cable Gland**

6. Connect the right angle male BNC plug to the exposed BNC cable from the cable gland assembly, as shown in Figure 19 below.



**Figure 19: Connecting BNC Plug to the Cable**

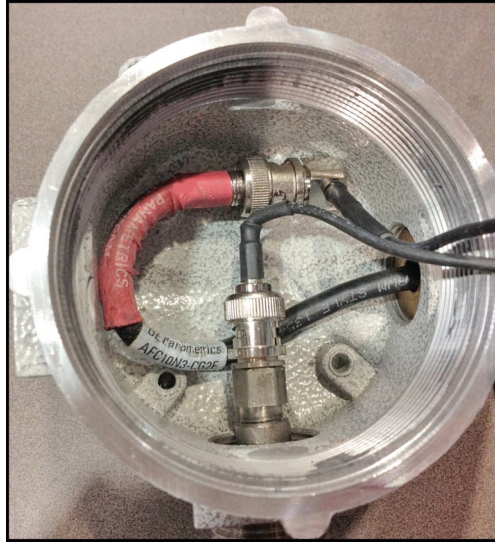
7. Connect the female BNC plug of the XAMP to the male BNC transducer head as shown in Figure 20 below:



**Figure 20: Female Plug to Male BNC Head**



8. Wrap the extra length of cable around the inside of the junction box such that the BNC heads do not rest on other cables or on each other. The assembly should now look like Figure 21 below.



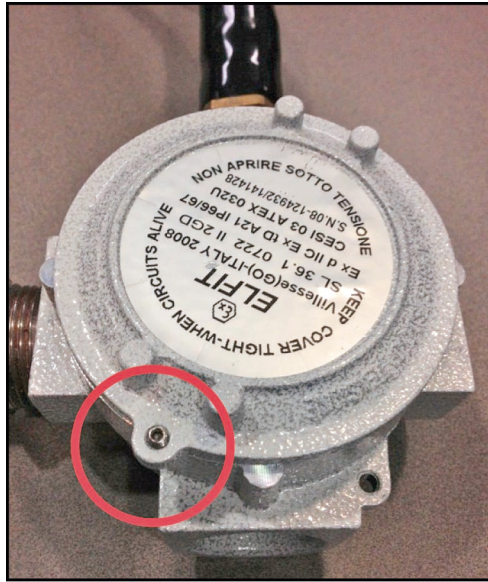
**Figure 21: BNC Heads**

9. Place the XAMP body into the junction box, resting the puck gently on the cables below it. To reduce stress and strain on the joint, ensure that the cables of the XAMP rest naturally according to the slant at which they exit the epoxy. The XAMP should remain still, and the cap of the junction box should rotate freely around the XAMP.



**Figure 22: Junction Box Cap**

10. Place the cap of the junction box over the XAMP and tighten the cap until the junction box is firmly closed. Engage the set screw (see Figure 23 below) to secure the cap in place.



**Figure 23: Junction Box Set Screw**





**Note:** To disconnect or uninstall the XAMP from the assembly, perform the above steps in reverse order.

## Chapter 4. Specifications

### 4.1 T5/T5 MAX Transducer Physical Specifications

<b>Applications:</b>	Hazardous Area, Flare Gas, Hydrocarbon Gases, Saturated Steam
<b>Installation Type:</b>	Wetted Standard: Titanium
<b>Material:</b>	<i>Optional: 316 Stainless Steel, Monel® or Hastelloy®</i>
<b>Field Mounting:</b>	Flowcell, Hot or Cold Tap
<b>Process Connection:</b>	Flanged, 1.5 in. to 3 in. (40 mm to 80 mm)
<b>Holder Type:</b>	Insertion Mechanism
<b>Holder Ratings:</b>	150#, 300#, 600# Standard: 100 kHz
<b>Operating Frequency:</b>	Optional: 50 kHz and 200 kHz
<b>Pressure Range:</b>	0 to 2700 psig Standard, 0 to 1500 psig for USA/Canada Certified Products
<b>Electrical Rating:</b>	200 V peak-to-peak, 5 mA
<b>Ambient Temperature Range:</b>	-40° to +140°F (-40° to +60°C)
<b>Process Temperature Range:</b>	-364° to +572°F (-220° to +300°C) -55°C to 150°C for T5 Max Only

### 4.2 T5/T5MAX Transducer Certifications

<b>North American - Explosion proof:</b>		Class I, Division 1, Group B, C, D
<b>European/International Flameproof:</b>		II 2 G Ex db IIC T6...XX Gb (T code dependent on Process Temperature) Tamb -40° to +140°F (-40° to +60°C) SIRA 20ATEX10001X, IECEx SIR 20.0006X
<b>North American - Weatherproof:</b>		IP66, TYPE 4X 200Vpp, 5mA
<b>European/International - Weatherproof:</b>	IP 66 	

### 4.3 Specific conditions of use

Consult the manufacturer if dimensional information on the flameproof joints is necessary.

It is end-user's responsibility to ensure that the ambient around the T5 and T5MAX assembly does not exceed the permitted ambient of -40°C to +60°C, regardless of process temperature.

The T5 and T5MAX transducers made of titanium (where ff = Ti) are potential ignitions sources when subjected to impact or friction, which shall be taken into consideration during installation.

The T5 and T5MAX have non-conducting coating which may generate an ignition-capable level of electrostatic charge under certain extreme conditions. The user shall take the necessary precautions to minimise the risk from electrostatic discharge. For example, controlling the environmental humidity where installed in order to minimize generation of static electricity, with the equipment protected from direct airflow which could cause a transfer of charge to the surface of the equipment. Cleaning should be done only with a damp cloth.

The temperature classification rating of the T5 and T5MAX assemblies is dependent upon the maximum process temperature (see table below).

**Table 3: Temperature Classification Rating of the T5 and T5MAX**

Model (where aa = T5, T5MAX)	Process temperature	T-Class
aa-bb-cc-dd-LT-ff-gg-hh-ii-jj-zz	-220°C to +85°C	T6
	+85°C to +100°C	T5
aa-bb-cc-dd-NT-ff-gg-hh-ii-jj-zz	-55°C to +85°C	T6
	+86°C to +100°C	T5
	+101°C to +135°C	T4
	+136°C to +150°C	T3
aa-bb-cc-dd-HT-ff-gg-hh-ii-jj-zz	-50°C to 85°C	T6
	+86°C to +100°C	T5
	+101°C to +135°C	T4
	+136°C to +200°C	T3
	+201°C to +250°C	T2
aa-bb-cc-dd-XT-ff-gg-hh-ii-jj-zz	-180°C to 85°C	T6
	+86°C to +100°C	T5
	+101°C to +135°C	T4
	+136°C to +200°C	T3
	+201°C to +300°C	T2



---

## Warranty

Each instrument manufactured by Panametrics is warranted to be free from defects in material and workmanship. Liability under this warranty is limited to restoring the instrument to normal operation or replacing the instrument, at the sole discretion of Panametrics. Fuses and batteries are specifically excluded from any liability. This warranty is effective from the date of delivery to the original purchaser. If Panametrics determines that the equipment was defective, the warranty period is:

- One year from delivery for electronic or mechanical failures.
- One year from delivery for sensor shelf life.

If Panametrics determines that the equipment was damaged by misuse, improper installation, the use of unauthorized replacement parts, or operating conditions outside the guidelines specified by Panametrics, the repairs are not covered under this warranty.

---

**The warranties set forth herein are exclusive and are in lieu of all other warranties whether statutory, express or implied (including warranties or merchantability and fitness for a particular purpose, and warranties arising from course of dealing or usage or trade).**

---

## Return Policy

If a Panametrics instrument malfunctions within the warranty period, the following procedure must be completed:

1. Notify Panametrics, giving full details of the problem, and provide the model number and serial number of the instrument. If the nature of the problem indicates the need for factory service, Panametrics will issue a RETURN MATERIAL AUTHORIZATION (RMA), and shipping instructions for the return of the instrument to a service center will be provided.
2. If Panametrics instructs you to send your instrument to a service center, it must be shipped prepaid to the authorized repair station indicated in the shipping instructions.
3. Upon receipt, Panametrics will evaluate the instrument to determine the cause of the malfunction.

Then, one of the following courses of action will then be taken:

- If the damage is covered under the terms of the warranty, the instrument will be repaired at no cost to the owner and returned.
- If Panametrics determines that the damage is not covered under the terms of the warranty, or if the warranty has expired, an estimate for the cost of the repairs at standard rates will be provided. Upon receipt of the owner's approval to proceed, the instrument will be repaired and returned.

[no content intended for this page]



## Customer Support Centers

### U.S.A.

The Boston Center  
1100 Technology Park Drive  
Billerica, MA 01821

U.S.A.

Tel: 800 833 9438 (toll-free)  
978 437 1000

E-mail: [panametricstechsupport@bakerhughes.com](mailto:panametricstechsupport@bakerhughes.com)

### Ireland

Sensing House  
Shannon Free Zone East  
Shannon, County Clare  
Ireland

Tel: +353 (0)61 470291

E-mail: [panametricstechsupport@bakerhughes.com](mailto:panametricstechsupport@bakerhughes.com)

Scan here for Panametrics  
support and service information



Copyright 2024 Baker Hughes company.

This material contains one or more registered trademarks of Baker Hughes Company and its subsidiaries in one or more countries. All third-party product and company names are trademarks of their respective holders.

BH045C21 EN G (04/2024)

**Baker Hughes** 