

# 4700E/4800E

## Electropneumatic Positioners

ATEX Instruction Manual (Rev.D)



**THESE INSTRUCTIONS PROVIDE THE CUSTOMER/OPERATOR WITH IMPORTANT PROJECT-SPECIFIC REFERENCE INFORMATION IN ADDITION TO THE CUSTOMER/OPERATOR'S NORMAL OPERATION AND MAINTENANCE PROCEDURES. SINCE OPERATION AND MAINTENANCE PHILOSOPHIES VARY, BAKER HUGHES (AND ITS SUBSIDIARIES AND AFFILIATES) DOES NOT ATTEMPT TO DICTATE SPECIFIC PROCEDURES, BUT TO PROVIDE BASIC LIMITATIONS AND REQUIREMENTS CREATED BY THE TYPE OF EQUIPMENT PROVIDED.**

**THESE INSTRUCTIONS ASSUME THAT OPERATORS ALREADY HAVE A GENERAL UNDERSTANDING OF THE REQUIREMENTS FOR SAFE OPERATION OF MECHANICAL AND ELECTRICAL EQUIPMENT IN POTENTIALLY HAZARDOUS ENVIRONMENTS. THEREFORE, THESE INSTRUCTIONS SHOULD BE INTERPRETED AND APPLIED IN CONJUNCTION WITH THE SAFETY RULES AND REGULATIONS APPLICABLE AT THE SITE AND THE PARTICULAR REQUIREMENTS FOR OPERATION OF OTHER EQUIPMENT AT THE SITE.**

**THESE INSTRUCTIONS DO NOT PURPORT TO COVER ALL DETAILS OR VARIATIONS IN EQUIPMENT NOR TO PROVIDE FOR EVERY POSSIBLE CONTINGENCY TO BE MET IN CONNECTION WITH INSTALLATION, OPERATION OR MAINTENANCE. SHOULD FURTHER INFORMATION BE DESIRED OR SHOULD PARTICULAR PROBLEMS ARISE WHICH ARE NOT COVERED SUFFICIENTLY FOR THE CUSTOMER/OPERATOR'S PURPOSES THE MATTER SHOULD BE REFERRED TO BAKER HUGHES.**

**THE RIGHTS, OBLIGATIONS AND LIABILITIES OF BAKER HUGHES AND THE CUSTOMER/OPERATOR ARE STRICTLY LIMITED TO THOSE EXPRESSLY PROVIDED IN THE CONTRACT RELATING TO THE SUPPLY OF THE EQUIPMENT. NO ADDITIONAL REPRESENTATIONS OR WARRANTIES BY BAKER HUGHES REGARDING THE EQUIPMENT OR ITS USE ARE GIVEN OR IMPLIED BY THE ISSUE OF THESE INSTRUCTIONS.**

**THESE INSTRUCTIONS ARE FURNISHED TO THE CUSTOMER/OPERATOR SOLELY TO ASSIST IN THE INSTALLATION, TESTING, OPERATION, AND/OR MAINTENANCE OF THE EQUIPMENT DESCRIBED. THIS DOCUMENT SHALL NOT BE REPRODUCED IN WHOLE OR IN PART WITHOUT THE WRITTEN APPROVAL OF BAKER HUGHES.**

# Table Of Contents

Warning.....	1
Instrument Operations.....	1
<b>1. Numbering System.....</b>	<b>2</b>
<b>2. Technical Data.....</b>	<b>2</b>
2.1. Performances.....	2
2.2. Schematic.....	2
<b>3. ATEX Markings.....</b>	<b>3</b>
<b>4. Electrical Connections and Conduit Entry.....</b>	<b>3</b>
4.1. Current Signal.....	3
4.2. Maximum Power.....	4
4.3. Intrinsic Safety Entity Parameters.....	4
4.4. Conduit Entry in Flameproof Application.....	4
<b>5. Assembly of 4700E or 4800E Positioner on a Valve.....</b>	<b>4</b>
<b>6. Pneumatic Connection of Positioner on a Valve.....</b>	<b>4</b>
<b>7. Installation and Start Up.....</b>	<b>5</b>
7.1 Installation.....	5
7.2 Start-Up.....	5
<b>8. Calibration of the 4700 E/4800 E Positioner.....</b>	<b>5</b>
<b>9. Maintenance Service.....</b>	<b>5</b>
9.1. General Rules.....	5
9.2. Before Maintenance Activity.....	5
9.3. During Maintenance Activity.....	5
9.4. After Maintenance Activity.....	7
<b>10. Safe Installation.....</b>	<b>8</b>
10.1. For Intrinsic Safety and Flameproof.....	8
10.2. For Intrinsic Safety.....	8
10.3. For Flameproof.....	8

## **WARNING**

**BEFORE installing, using or carrying out any maintenance tasks associated with this instrument, READ THE INSTRUCTIONS CAREFULLY.**

These instruments comply with the essential safety requirements of the European Directive ATEX 2014/34/EU.

It is certified to be used in Gas or Dust explosive atmospheres, groups IIC or IIIC:

Category II 1GD – zones 0, 1, 2, 20, 21 and 22 for the protection mode “ia”

Category II 2GD – zones 1, 2, 21 and 22 for the protection mode “db” and “tb”.

They also comply with the essential safety requirements of the European Directive EMC 2014/30/EU as amended, for use within an industrial environment.

It is the end user’s responsibility to:

- Verify material compatibility with the application
- Ensure proper use of fall protection when working at heights, per Safe Site Work Practices
- Ensure use of proper Personal Protective Equipment
- Take the appropriate actions to ensure that site personnel who are performing installation, commissioning and maintenance have been trained in proper site procedures for working with and around equipment, per Safe Site Work Practices

Products certified as explosion proof equipment MUST BE:

- a) Installed, put into service, used and maintained in compliance with European and/or national and local regulations and in accordance with the recommendations contained in the relevant standards concerning potentially explosive atmospheres.
- b) Used only in situations those comply with the certification conditions shown in this document and after verification of their compatibility with the zone of intended use and the permitted maximum ambient temperature.
- c) Installed, put into service and maintained by qualified and competent professionals who have been trained in proper site procedures for instrumentation used in areas with potentially explosive atmosphere and for working with and around equipment, per Safe Site Work Practices.

Under certain operating conditions, the use of damaged instruments could cause a degradation of the performances of the system which may lead to personal injury or death.

Use only genuine replacement parts, which are provided by the manufacturer, to guarantee that the products comply with the essential safety requirements of the European Directives mentioned above.

## **INSTRUMENT OPERATION**

4700E/4800E apparatus: electro pneumatic positioner (force balanced principle) with integrated current to pressure converter (4000 I/P Converter). It controls the position of the plug of a control valve to a 4-20 mA control signal. Feedback is obtained by means of a cam.

4800E is a positioner with a high flow pneumatic block.

# 1. Numbering System

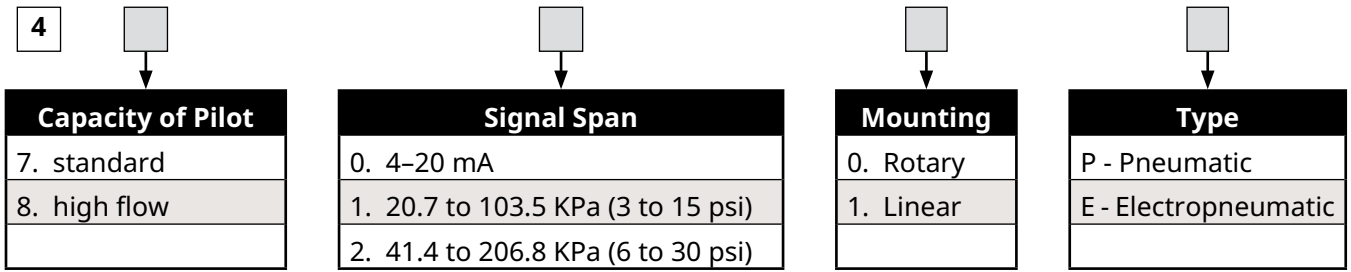

## 2. Technical Data

### 2.1. Performance

Performance (% of the signal range)	4700E	4800E
Dead Zone	< 0.5	< 0.5
Hysteresis	< 0.5	< 0.8
Repeatability	0.5	0.5
Sensitivity	0.3	0.5
Conformity	± 1	±1
Input impedance	170 ohms	170 ohms

Maximum service temperature range: (refer to the marking on the apparatus).

Standard Instrument: -40°C to +85°C (-40°F to +185°F)

Storage temperature: -55°C to +90°C (-67°F to +194°F)

The components of the I/P Module are protected by a metallic housing. Housing electrical protection index: IP 66.

### 2.2. Schematic

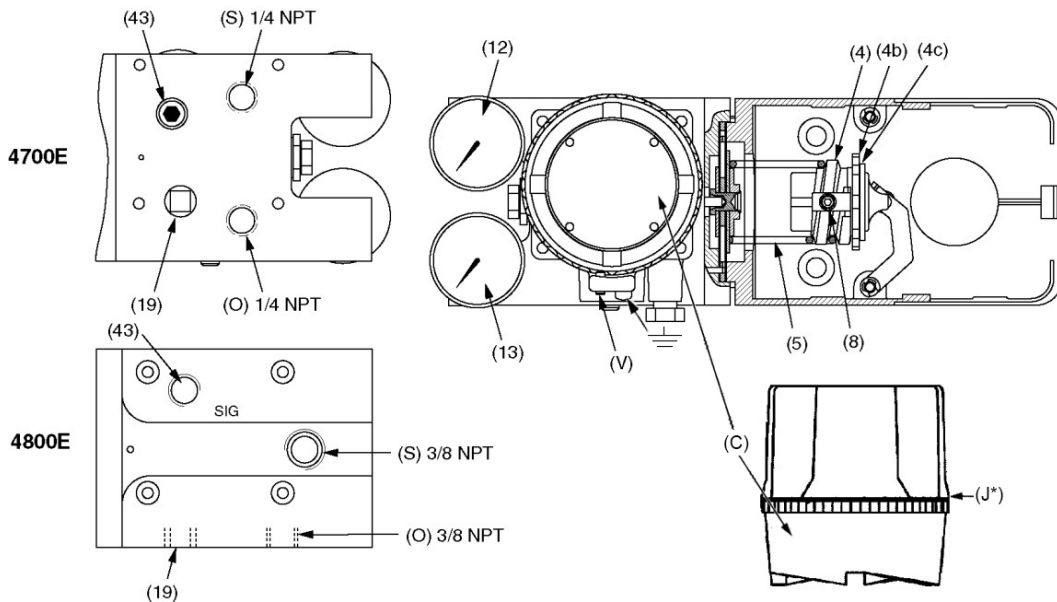

Ref. No.	Description	Ref. No.	Description	Ref. No.	Description
4	Spring End	12	Supply Gauge	C	Cover
4b	Zero Nut	13	Output Gauge	J*	O-Ring Seal
4c	Zero Lock Nut	19	Vent Plug	O	Output
5	Feedback Spring	43	Plug	S	Supply
8	Socket Head Screw			V	Safety Screw

\*O-Ring seal is not visible.

### 3. ATEX MARKINGS

ITS-I21ATEX29368X

Notified Body CE XXXX

(See Product Label for NB Number)

Intrinsic Safety: II 1GD:

- Ex ia h IIC T6 Ga (Tamb.= -40°C to +55°C, Pi= 0.33 W)
- Ex ia h IIC T4 Ga (Tamb.= -40°C to +80°C, Pi= 1.1 W)
- Ex ia h IIIC Da T90°C (Tamb.= -40°C to +80°C, Pi= 1.1 W)

Flame Proof: II 2GD:

- Ex db h IIC T6 Gb (Tamb.= -40°C to +55°C)
- Ex db h IIC T5 Gb (Tamb.= -40°C to +70°C)
- Ex db h IIC T4 Gb (Tamb.= -40°C to +85°C)
- Ex tb IIIC T90°C Db (Tamb.= -40°C to +55°C)

IP 66 / Type 4X

#### WARNING:

- Do not open when energized.
- Do not open when an explosive gas atmosphere is present.
- Potential electrostatic charging hazard. See instructions for safe use.
- Use cables rated to  $\geq 5^\circ\text{C}$  above ambient.

### 4. ELECTRICAL CONNECTIONS and CONDUIT ENTRY

- **Comply with current national and local regulations for electrical installation work.**
- **Comply with national and local explosive atmosphere regulations.**
- **Before carrying out any work on the device, power off the instrument or make sure that the local conditions in the potentially explosive atmosphere permit the safe opening of the cover.**
- **Before switching on or after doing any work on the device, always tighten the cover (C) with a seal (J) in good condition and put back the safety screw (V).**

The Positioner must be installed and put into service in conformance with **EN/IEC 60079-14, EN/IEC 61241-14** and / or national and local regulations applicable for explosive atmospheres.

#### 4.1. Current signal

The Positioner is self-powered 4-20mA current receiver. Connect the wires to the instrument's terminals, taking care of complying with polarities + and -, the terminals will accept wire sizes up to AWG 14.

Make the earth connections with the internal and external ground terminals.

- Input signal: 4-20 mA,
- Input impedance: 170 ohms.

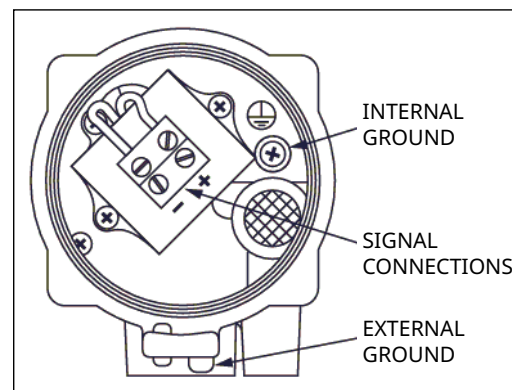

## 4.2. Maximum Power

- 0.8 W for Flameproof atmosphere
- 1.1 W or 0.33 W for Intrinsic Safety atmosphere

## 4.3. Intrinsic Safety entity parameters

Entity parameters		T4	T6	Unit
Max. Input Voltage	Ui	30	30	V
Max. Input Current	Ii	110	110	mA
Max. Input Power	Pi	1100	0.33	mW
Max. Internal Capacitance	Ci	0	0	nF
Max. Internal Inductivity	Li	0	0	μH

## 4.4 Conduit entry in flameproof application

The connections can be done with different variations taking into account approved manufacturer and requested approvals:

A cable entry of a certified type Ex d IIC / Ex tD A21 or Ex t IIIC Db can be mounted directly on the single ½" NPT (**ANSI/ASME B1.20.1**) housing conduit connection or M20 (**ISO965-1 & ISO965-3**)

For identification machining thread, check the part number sticker on the Model 4000 I/P Converter body

M20	00-055100106-888
½ NPT	00-055100212-888

- Adaptors or reducers if apparatus certified ATEX or IECEx.

## 5. ASSEMBLY OF A 4700E OR 4800E POSITIONER ON A VALVE

- **Comply with current national and local regulations for electrical installation work.**
- **Comply with national and local explosive atmosphere regulations.**
- **Before carrying out any work on the device, power off the instrument or make sure that the local conditions in the potentially explosive atmosphere permit the safe opening of the cover.**
- **Before switching on or after doing any work on the device, always tighten the cover (C) with a seal (J) in good condition and put back the safety screw (V).**

**Note:** Before installation, check that the device is undamaged. In the event of damage, inform the manufacturer whose address is shown on the serial plate.

If the positioner is supplied mounted on a valve, Baker Hughes installs it, make the pneumatic connection and configure and calibrate it.

When the positioner is shipped alone, the user is responsible for its installation, electrical and pneumatic connections and its calibration.

Please refer to operating instruction manual 19515 for more details.

## 6. PNEUMATIC CONNECTION OF POSITIONER 4700E / 4800E

- **Make sure that the air supply pressure is suitable for the installation and for the instrument.**
- **When using a positioner make sure that the air supply pressure matches the one specified on the serial plate without exceeding 700 kPa (100 psi).**
- **The positioners are intended for use with industrial compressed air or natural gas systems only; natural gas systems are Zone 0 or Div 1 installations.**

If the instrument has been shipped alone, make pneumatic connections as per § 2.2: air supply pressure to input (S) and output (O) to the actuator.

Minimum diameter of tubing:

- 4700E: 4 x 6 mm
- 4800E: 10 x 12 mm

## 7. INSTALLATION and START UP

These operations must be put into service in conformance with **EN/IEC 60079-17** and / or national and local regulations applicable for explosive atmospheres.

Before carrying out any work on the device, check that the local conditions in the potentially explosive atmosphere zone permit the safe opening of the covers.

### 7.1. Installation

Explosionproof instrument can be installed in flammable gas explosive atmosphere groups IIC for the zones 1 and 2 or in flammable dust explosive atmosphere group IIIC zones 21 and 22. Intrinsically safe instrument can be installed in flammable gas explosive atmospheres groups IIC for the zones 0, 1 and 2 or in flammable dust explosive atmosphere group IIIC zones 20, 21 and 22.

Note: Since the apparatus has multiple certifications: "ia", "db" and "tb", it is recommended that the type of installation "Ex ia", "Ex db" and "Ex tb" is identified on, or next to the apparatus.

### 7.2. Start-up

**Note: Before start-up, proceed, if required, with instrument calibration as per § 8 and/or ensure that all the safety instructions in the preceding paragraphs have been strictly followed.**

- Before switching on or after doing any work on the device, always tighten the cover (C) with a seal (J) in good condition and put back the safety screw (V).
- Check that the cable gland is certified for the intended use and that the electrical data are suitable for the operating zone.

## 8. CALIBRATION OF THE 4700E/4800E POSITIONER

- Comply with current national and local regulations for electrical installation work.
- Comply with national and local explosive atmosphere regulations.
- Before carrying out any work on the device, power off the instrument or make sure that the local conditions in the potentially explosive atmosphere permit the safe opening of the cover.
- Before switching on or after doing any work on the device, always tighten the cover (C) with a seal (J) in good condition and put back the safety screw (V).

The positioner mounted on the valve is factory calibrated. If it is supplied alone, calibration will be carried out by the customer, as follows:

- Make the electrical and pneumatic connections, see § 4 and § 6.
- The zero is set using the nut (4b). Adjust the nut (4b) so that the valve is close for the signal value that corresponds to the closure of the valve.
- The span is adjusted using the spring (5). Turn the spring (5) on the spring end (4), to increase or reduce the number of active coils, thus reducing or increasing the stiffness of the spring. These operations are carried out to adjust the span so as that the valve describes its entire stroke for the full range of the control signal.
- These two operations are repeated until the correct settings are obtained.
- Lock the zero lock nut (4c) and the socket head screw (8)

**Note: The Model 4000 I/P Converter does not require any adjustment.**

## 9. MAINTENANCE SERVICE

**Comply with current national and local regulations for electrical installation work.**

**Comply with national and local explosive atmosphere regulations.**

**Before carrying out any work on the device, power off the instrument or make sure that the local conditions in the potentially explosive atmosphere permit the safe opening of the cover.**

**Before switching on or after doing any work on the device, always tighten the cover (C) with a seal (J) in good condition and put back the safety screw (V).**

### 9.1. General rules

These operations must be put into service in conformance with **EN/IEC 60079-17** and / or national and local regulations applicable for explosive atmospheres.

### 9.2. Before maintenance activity

Before carrying out any work on the device, check that the local conditions in the potentially explosive atmosphere zone permit the safe opening of the cover (C).



**SYSTEM DRAWING SYS Sira Ex12Y2005**

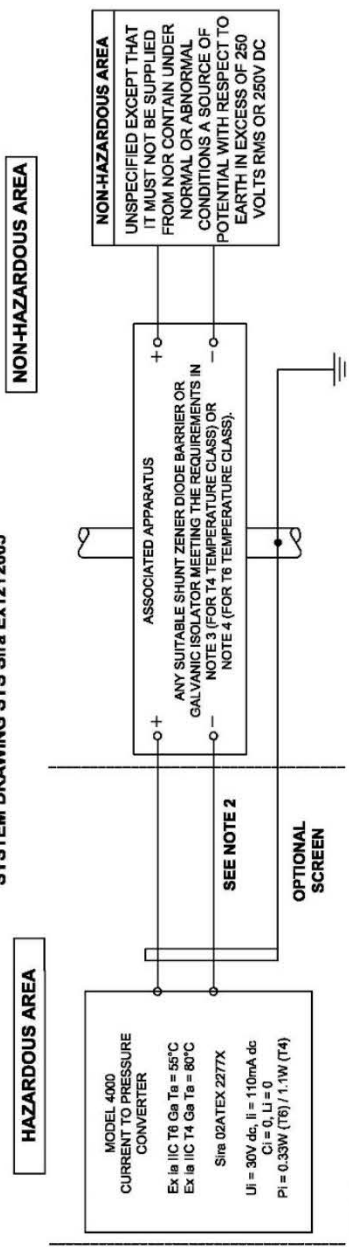

**NON-HAZARDOUS AREA**  
 UNSPECIFIED EXCEPT THAT IT MUST NOT BE SUPPLIED FROM NOR CONTAIN UNDER NORMAL OR ABNORMAL CONDITIONS A SOURCE OF POTENTIAL WITH RESPECT TO EARTH IN EXCESS OF 250 VOLTS RMS OR 250V DC

**HAZARDOUS AREA**

**TABLE 1**

GROUP	MAXIMUM CABLE CAPACITANCE	MAXIMUM CABLE INDUCTANCE	MAXIMUM CABLE
	Cc	Lc	Lo/Rc RATIO
IIC	83 nF	2.9 mH	46 μH/Ω
IIB	650 nF	11.7 mH	185 μH/Ω
IIA	2150 nF	23.5 mH	370 μH/Ω

**NOTES**

1. THE ELECTRICAL CIRCUIT IN THE HAZARDOUS AREA MUST BE CAPABLE OF WITHSTANDING AN A.C. TEST VOLTAGE OF 500 VOLTS R.M.S. TO EARTH OR FRAME OF THE APPARATUS FOR 1 MINUTE.
2. THE CAPACITANCE AND INDUCTANCE OR INDUCTANCE/RESISTANCE (L/R) RATIO OF THE HAZARDOUS AREA CABLES MUST NOT EXCEED THE VALUES SPECIFIED IN TABLE 1.  
 WHERE THE INTERCONNECTING CABLE UTILIZES PART OF A MULTI-CORE CABLE CONTAINING OTHER INTRINSICALLY SAFE CIRCUITS, THEN THE MULTI-CORE CABLE SHALL BE IN ACCORDANCE WITH THE REQUIREMENTS OF A MULTI-CORE CABLE TYPE A OR TYPE B, AS SPECIFIED IN CLAUSE 9 OF IEC 60079-25.

**HAZARDOUS AREA**

3. ONE CHANNEL OF A POSITIVE POLARITY, 28V BARRIER OR ISOLATOR, CERTIFIED [Ex Ia] IIC OR [Ex Ib] IIC, WITH OUTPUT PARAMETERS AS FOLLOWS:  
 Uo NOT GREATER THAN 28V, Io NOT GREATER THAN 110mA,  
 A SOURCE RESISTANCE OF 255 OHMS MINIMUM  
 Co AT LEAST 83nF, Lo AT LEAST 2.9mH, Lo/Ro AT LEAST 46μH/OHM
4. ONE CHANNEL OF A POSITIVE POLARITY, 28V BARRIER OR ISOLATOR, CERTIFIED [Ex Ia] IIC OR [Ex Ib] IIC, WITH OUTPUT PARAMETERS AS FOLLOWS:  
 Uo NOT GREATER THAN 28V, Io NOT GREATER THAN 110mA,  
 A SOURCE RESISTANCE OF 600 OHMS MINIMUM  
 Co AT LEAST 83nF, Lo AT LEAST 2.9mH, Lo/Ro AT LEAST 46μH/OHM

5. THE INSTALLATION INCLUDING THE BARRIER EARTHING ARRANGEMENTS (IF APPLICABLE), SHALL COMPLY WITH THE INSTALLATION REQUIREMENTS IN THE COUNTRY OF USE, E.G. IECEN 60079-14.  
 INSTALLATION SHALL ALSO BE IN ACCORDANCE WITH THE MANUFACTURER'S GUIDELINES.
6. SPECIAL CONDITIONS FOR SAFE USE SPECIFIED ON CERTIFICATES SIRA 02ATEX 2277X MUST BE OBSERVED.

**CERTIFIED PRODUCT**  
 No modifications are permitted without the approval of  
**SIRA**

UNSPECIFIED TOLERANCES  
 X ±0.5mm X XX ±0.15mm  
 XX ±0.25mm ANGLES ±1°  
 DIM NOT SCALE DRAWING

PART No: -  
 FINISH -  
 REMOVE ALL BURRS & SHARP EDGES TO 0.15 MAX SURFACE FINISH 32/ UNLESS OTHERWISE STATED  
 MATERIAL -

THIS DRAWING AND DESIGN ARE CONFIDENTIAL.  
 COPYRIGHT © 1996 NORGREN LTD  
 TITLE MODEL 4000 I.S. System (SIRA)  
 DATE CREATED 01/03/2012  
 DRG NO: 9G-109 ISSUE: p  
 SIZE A3  
 DRAWN TO BS6888 SHEET 1 OF 1

## TRANSLATION OF ENGLISH I.S. SYSTEM DRAWING:

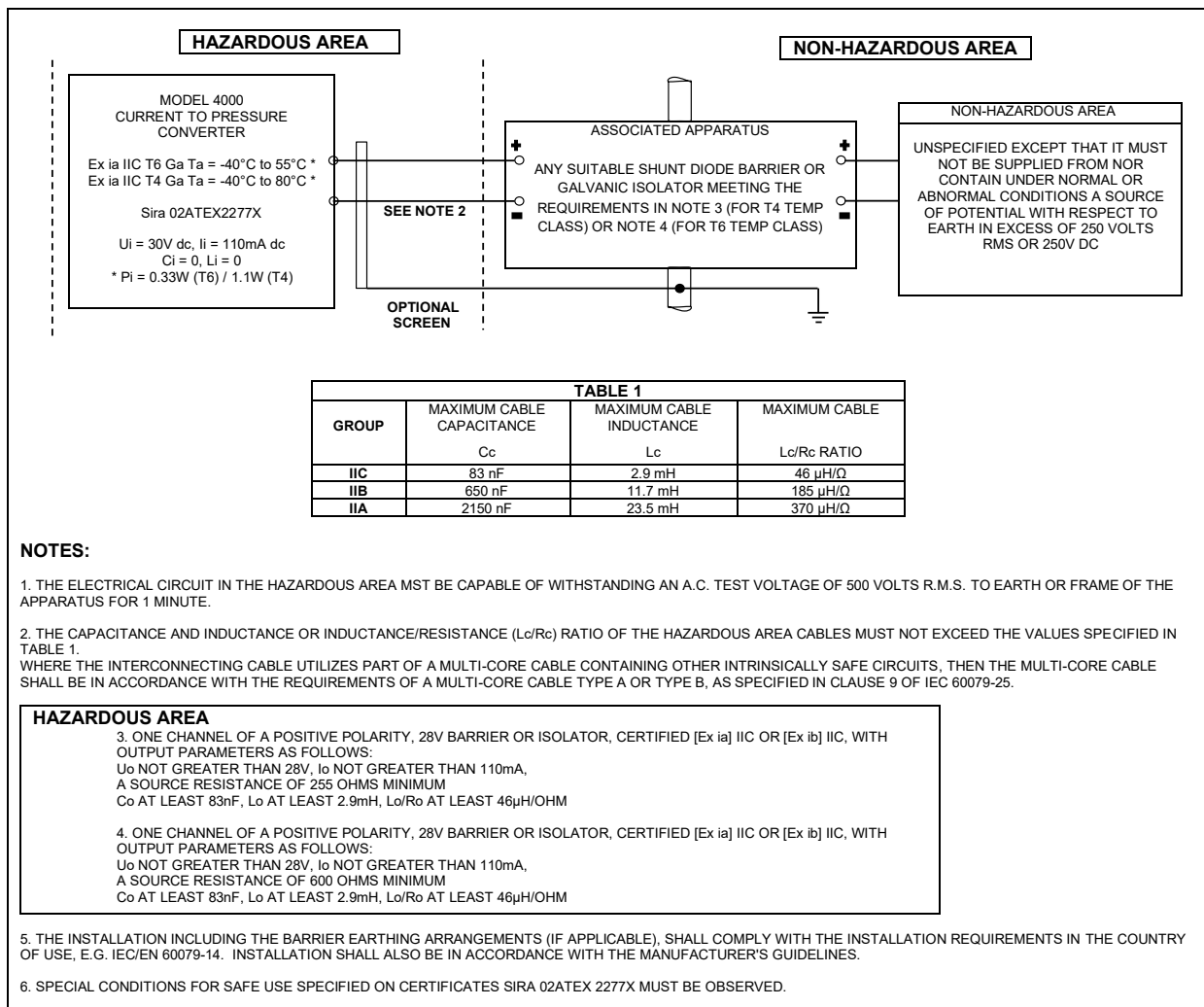

### 9.3. During maintenance activity

Take into account all special conditions of use points listed § 10. Pay particular attention to the following points:

- Check that no part is damaged. In the event of damage, replace the defective parts with genuine manufacturer's replacement parts only.
- Check the general condition of the main cover seal (C) and the housing.
- Check the gland and the electrical connections.
- Check the pilot:
  - Disconnect the air supply and remove the pilot from the pneumatic block
  - After disassembly of the pilot (see picture below) clean parts and blow air through the ports and tubing. The reassembly of the pilot is done in accordance with the figure below by using three new O rings. Screw the assembly in the pneumatic block.

- When replacing the I/P module, check the condition of the three 'O' ring (22, 23 24) and replace them if necessary.
- To proceed to a cleaning of the different sides of the enclosure to avoid the deposits of dusts for instruments working in zones 20, 21 and 22.
- Avoid contact of the apparatus with aggressive substances which could damage the metallic or plastic parts.

### 9.4. After maintenance activity

After doing any work on the device, check the cover (C) is fully screwed and the security cover screw is well locked (V).

## 10. SAFE INSTALLATION

### 10.1. For Intrinsic Safety and Flameproof

- It is under the user responsibility to check once a year the gasket and in the event of damage to replace the defective parts with manufacturer's replacement parts only.
- For use in dusty hazardous areas, the user will have to proceed to a cleaning regularly the different sides of the enclosure to avoid the deposits of dusts, the maximum thickness must be <5 mm. For safe operation, this can be done only if the local conditions around the device are free of potentially explosive atmosphere.
- The user will have to check the temperature increase on the positioner coming from the mechanical part in contact with or through the process thermal radiation be less or equal than the temperature classification allowed. This must be done in conformance with EN/IEC 60079-14 and / or national and local regulations applicable for explosive atmospheres.
- The user to only wipe/clean with a damp cloth or when in a non-hazardous area when cleaning the device and non-metallic parts/label to avoid any electrostatic spark. For safe operation, this can be done only if the local conditions around the device are free of potentially explosive atmosphere.

### 10.2. For Intrinsic Safety

- The cable entry must have a protection level at least equal to IP54 according to EN/IEC 60529 standards.
- For the housing with aluminum material, the user will have to determine the use of the device for group II category 1 (zone 0) against potential inflammable source causing by sparks in the event of impact or friction.
- The current source supply connected on the Model 4000 connectors must be certified for use in group IIC and intrinsic safety loop approved. The entity parameters of the current source supply must be compatible with the entity parameters of the Model 4000 I/P Converter described § 4.3.
- The enclosure is made from light metal which could cause ignition due to impact. This shall be taken

into consideration when the apparatus is installed in locations that specifically require Equipment Protection Levels Ga or Da.

- If the Model 4000 I/P Converter is mounted with the axis of the plastic baffle in the vertical position with the baffle uppermost, the required ingress protection against water is invalidated; therefore, it shall only be installed in this orientation if its location provides protection against falling water.

### 10.3. For Flameproof

- For ambient temperature greater than 70°C, the user must choice a cable entry and a cable compatible with:

Ambient Temperature	Cable and Cable Entry Temperature
70°C	75°C
85°C	90°C

- The cable entry and the cable must be compatible with the minimum temperature of -40°C indicated on the marking plate.
- The cable entry must have a protection level at least equal to IP66/67.

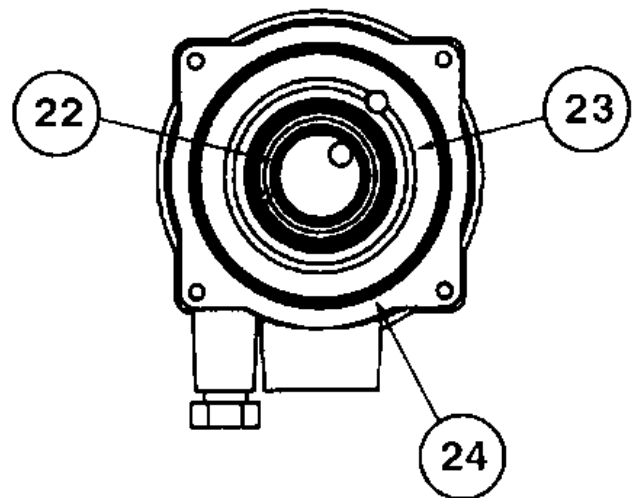
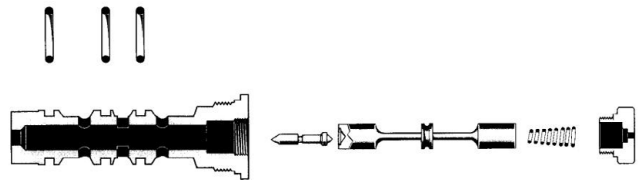

# Find the nearest local Channel Partner in your area:

[valves.bakerhughes.com/contact-us](https://valves.bakerhughes.com/contact-us)

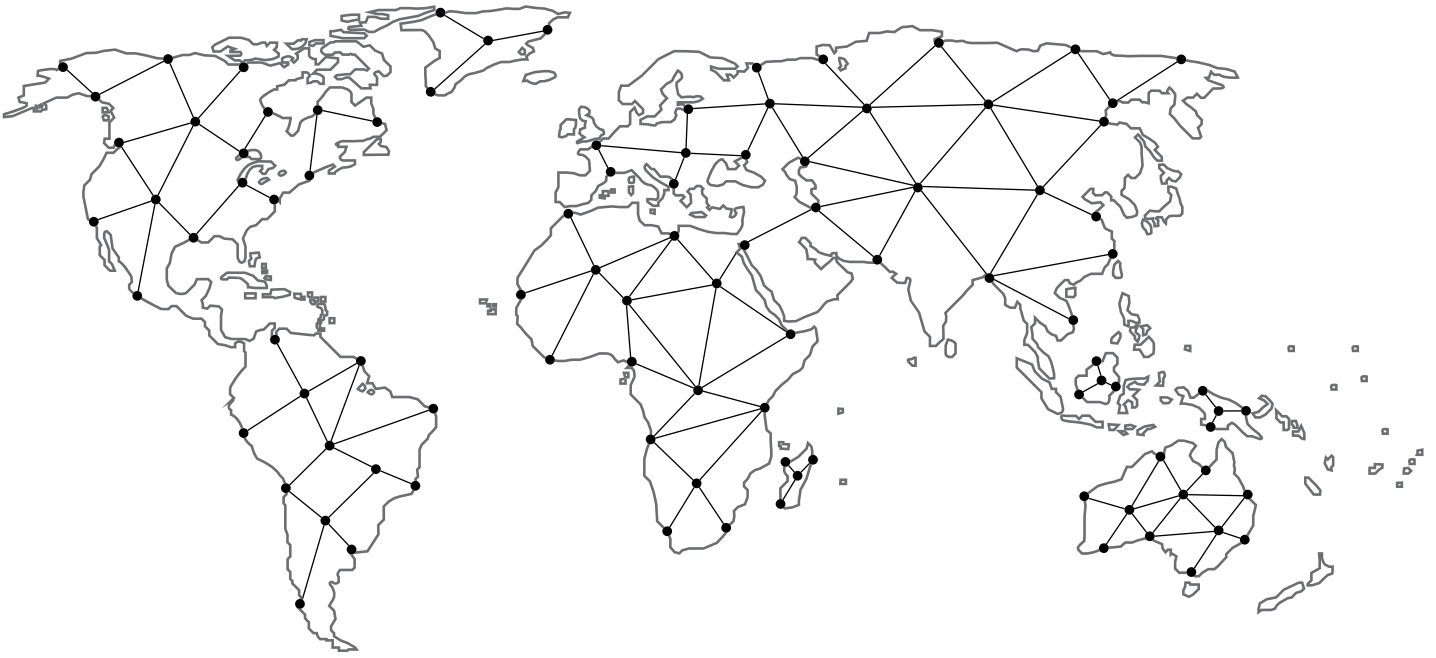

## Tech Field Support & Warranty:

Phone: +1-866-827-5378

[valvesupport@bakerhughes.com](mailto:valvesupport@bakerhughes.com)

[valves.bakerhughes.com](https://valves.bakerhughes.com)

Copyright 2021 Baker Hughes Company. All rights reserved. Baker Hughes provides this information on an "as is" basis for general information purposes. Baker Hughes does not make any representation as to the accuracy or completeness of the information and makes no warranties of any kind, specific, implied or oral, to the fullest extent permissible by law, including those of merchantability and fitness for a particular purpose or use. Baker Hughes hereby disclaims any and all liability for any direct, indirect, consequential or special damages, claims for lost profits, or third party claims arising from the use of the information, whether a claim is asserted in contract, tort, or otherwise. Baker Hughes reserves the right to make changes in specifications and features shown herein, or discontinue the product described at any time without notice or obligation. Contact your Baker Hughes representative for the most current information. The Baker Hughes logo and Masoneilan are trademarks of Baker Hughes Company. Other company names and product names used in this document are the registered trademarks or trademarks of their respective owners.

