



Reuter-Stokes ^3He filled position sensitive proportional counter – RS-P4-0424-201

Small angle neutron scattering, powder diffraction, nuclear material assay and industrial process control

Precision performance

^3He purification techniques and manufacturing process control ensure the precise matching of operating characteristics among large batches of counters. This allows parallel operation of numerous detectors without the need to separate power supplies.

Position sensitive

This proportional counter uses a highly resistive anode of nickelchrome, which helps determine positioning of the neutron event along the anode. Position resolution is typically 2.5mm to 5.0mm, and the charge division method of determining position resolution is recommended. It is important to properly match the detector preamplifier-amplifier electrical characteristics to determine accurate position resolution.

Product configurations

Proportional counters are available in diameters of 0.5" to 2.0" and sensitive lengths of 4.0" to 120.0". Construction can be either 304 stainless steel or 1100 aluminum.

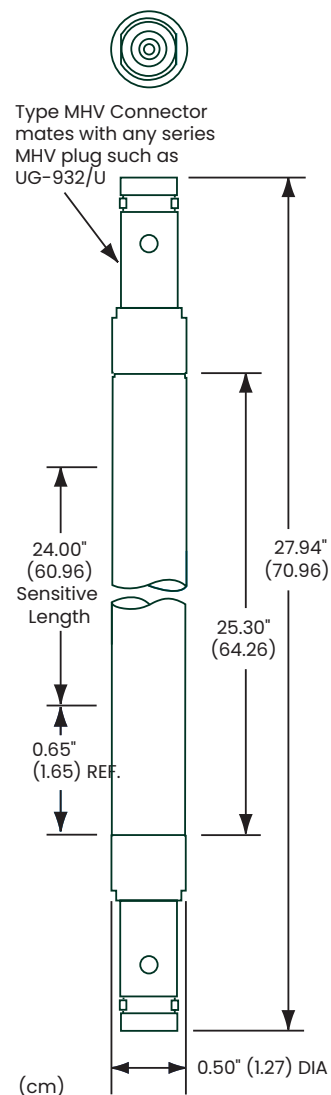

Sample specifications

This proportional counter is a sample of one of over 10,000 neutron counter designs we have manufactured. Please contact us if your application requires modification of the specifications given here.

A plot of true positions as measured with a 3mm collimator vs. PSD measurement typical counting arrangement

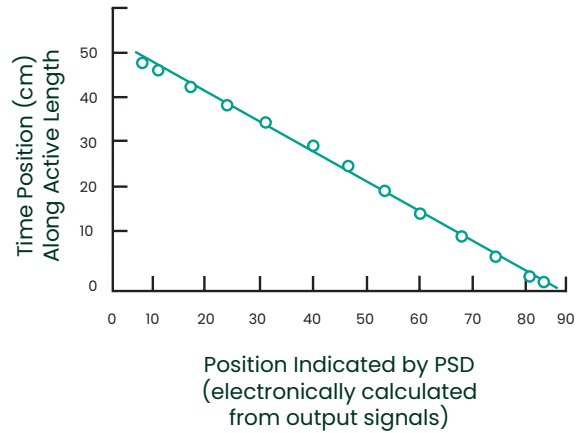

Specifications

Mechanical

- Maximum diameter: 1.32 cm
- Maximum overall length: 71.3 cm
- Connectors (2) type: MHV
- Net weight: 0.5 kg

Material

- Outer shell: 304 Stainless Steel
- Insulation: Alumina ceramic
- Anode: Nickel-chrome
- Neutron sensitive material: ^3He
- Fill pressure: 10 Atmospheres

Capacitance

- 10 pf

Resistance @ 25°C

- Detector: 10^{12} ohms
- Anode (@140 ohms/in): 3900 ohms

Maximum ratings

- Voltage: 2500V
- Temperature: 100°C

Typical operating characteristics

- Voltage range: 1200–1800 volts
- Energy Resolution (FWHM): 10–12%
- Position Resolution: 2.5–5 mm (see note)

Note: Position Resolution is greatly dependent on electronics used.

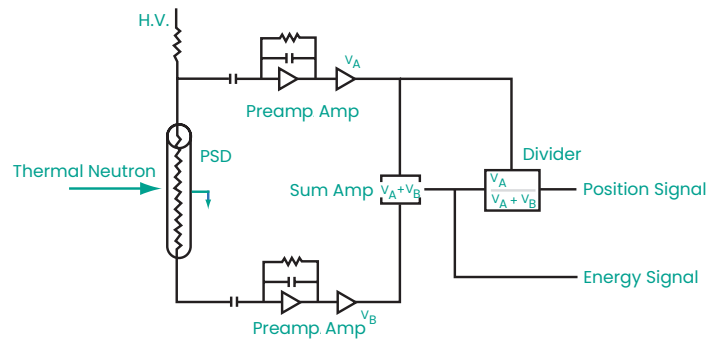
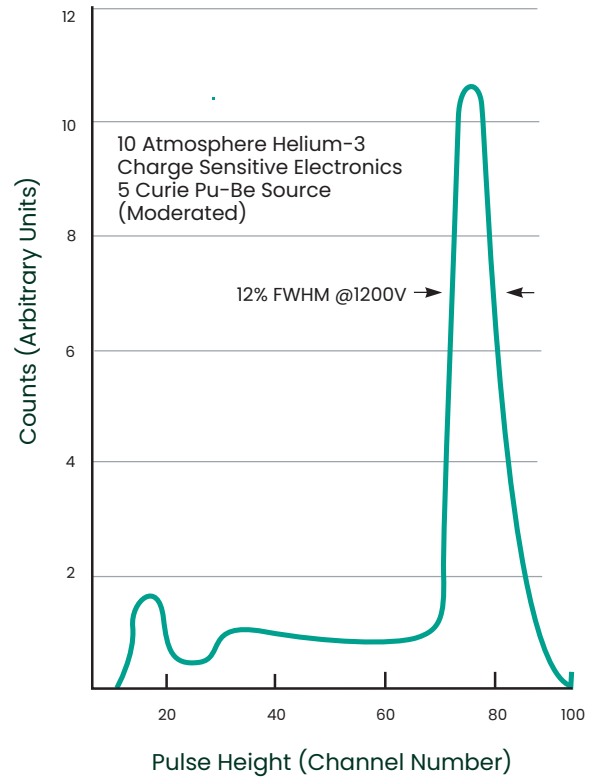

Baker Hughes 