

# Masoneilan

a Baker Hughes business

## 4700P/4700E and 4800P/4800E

### Pneumatic and Electropneumatic Positioners

#### Instruction Manual (Rev. H)



# About this Manual

This instruction manual applies to the Masoneilan 4700P/4700E and 4800P/4800E pneumatic and electropneumatic positioners.

The information contained in this manual, in whole or part, shall not be transcribed or copied without Baker Hughes' written permission.

In no case does this manual guarantee the merchantability of the positioner or the software or its adaptability to a specific client needs.

Please report any errors or questions about the information in this manual to your local supplier or visit [valves.bakerhughes.com](https://valves.bakerhughes.com).

## DISCLAIMER

**THESE INSTRUCTIONS PROVIDE THE CUSTOMER/OPERATOR WITH IMPORTANT PROJECT-SPECIFIC REFERENCE INFORMATION IN ADDITION TO THE CUSTOMER/OPERATOR'S NORMAL OPERATION AND MAINTENANCE PROCEDURES. SINCE OPERATION AND MAINTENANCE PHILOSOPHIES VARY, BAKER HUGHES COMPANY (AND ITS SUBSIDIARIES AND AFFILIATES) DOES NOT ATTEMPT TO DICTATE SPECIFIC PROCEDURES, BUT TO PROVIDE BASIC LIMITATIONS AND REQUIREMENTS CREATED BY THE TYPE OF EQUIPMENT PROVIDED.**

**THESE INSTRUCTIONS ASSUME THAT OPERATORS ALREADY HAVE A GENERAL UNDERSTANDING OF THE REQUIREMENTS FOR SAFE OPERATION OF MECHANICAL AND ELECTRICAL EQUIPMENT IN POTENTIALLY HAZARDOUS ENVIRONMENTS. THEREFORE, THESE INSTRUCTIONS SHOULD BE INTERPRETED AND APPLIED IN CONJUNCTION WITH THE SAFETY RULES AND REGULATIONS APPLICABLE AT THE SITE AND THE PARTICULAR REQUIREMENTS FOR OPERATION OF OTHER EQUIPMENT AT THE SITE.**

**THESE INSTRUCTIONS DO NOT PURPORT TO COVER ALL DETAILS OR VARIATIONS IN EQUIPMENT NOR TO PROVIDE FOR EVERY POSSIBLE CONTINGENCY TO BE MET IN CONNECTION WITH INSTALLATION, OPERATION OR MAINTENANCE. SHOULD FURTHER INFORMATION BE DESIRED OR SHOULD PARTICULAR PROBLEMS ARISE WHICH ARE NOT COVERED SUFFICIENTLY FOR THE CUSTOMER/OPERATOR'S PURPOSES THE MATTER SHOULD BE REFERRED TO BAKER HUGHES.**

**THE RIGHTS, OBLIGATIONS AND LIABILITIES OF BAKER HUGHES AND THE CUSTOMER/OPERATOR ARE STRICTLY LIMITED TO THOSE EXPRESSLY PROVIDED IN THE CONTRACT RELATING TO THE SUPPLY OF THE EQUIPMENT. NO ADDITIONAL REPRESENTATIONS OR WARRANTIES BY BAKER HUGHES REGARDING THE EQUIPMENT OR ITS USE ARE GIVEN OR IMPLIED BY THE ISSUE OF THESE INSTRUCTIONS.**

**THESE INSTRUCTIONS ARE FURNISHED TO THE CUSTOMER/OPERATOR SOLELY TO ASSIST IN THE INSTALLATION, TESTING, OPERATION, AND/OR MAINTENANCE OF THE EQUIPMENT DESCRIBED. THIS DOCUMENT SHALL NOT BE REPRODUCED IN WHOLE OR IN PART WITHOUT THE WRITTEN APPROVAL OF BAKER HUGHES.**

Copyright

All information contained herein is believed to be accurate at the time of publication and is subject to change without notice.

Copyright 2024 by Baker Hughes company. All rights reserved. PN 720014889-888- 0000 Rev. G.

# Document Changes

Rev / Date	Changes
B / 08-2014	Added paragraph to first page of Calibration section about post-shipment calibration.
C / 04-2015	Added Disclaimer paragraph and a new Figure 15.
D / 01-2020	Changed Valve Action references in High Performance Butterfly Valve cam and lever graphic in Calibration chapter. Removed Varimax, 39002, Paramax, 87U/88U and Ball II. Rebranded to Baker Hughes format.
E / 12-2020	Added Lockwasher part to Figures 18 and 19.
F / 01-2021	Added Lockwasher part to Figure 6.
G / 09-2024	Added UL and CSA standards for cETLus Picture for screws cover ATEX certificate update ATEX Marking update Drawing update with BH 4000 model representation

# Contents

<b>Safety Information</b> .....	7
<b>4700P/4700E and 4800P/4800E Product Safety</b> .....	8
General installation, maintenance or replacement .....	8
Hazardous Area Installation .....	8
<b>Introduction</b> .....	10
General Description and Operation .....	10
Pilot .....	11
Direct Action .....	11
Reverse Action .....	11
Cam .....	11
Optional bypass valve (4700P, Direct Acting Model only) .....	11
<b>Installation</b> .....	12
Mounting and Orientation .....	12
Cover Removal .....	13
<b>87/88 Actuator</b> .....	15
Mounting 4700P and 4700E on Series 87/88 Actuators .....	17
<b>Positioner Mounting and Orientation</b> .....	19
Camflex II, V-Max, MiniTork II, and Butterfly .....	19
<b>Pneumatic Installation</b> .....	21
<b>Electrical Installation of 4700E/4800E</b> .....	24
<b>Hazardous Area Installations</b> .....	25
US and Canadian Standards .....	25
US/NEC Approval .....	26
Canadian/CEC Approvals .....	27
ATEX Approvals .....	28
<b>Split Range Operation</b> .....	32
<b>Mounting Cam Coupling</b> .....	33
Mounting Cam .....	33
Lever Subassembly (S/A) Orientation .....	34
Changing Lever Subassembly (S/A) Orientation .....	34
<b>Calibration</b> .....	35
General .....	35
Zero Adjustment .....	36
Span Adjustment .....	36
Cam Lobe Change .....	37
Air to Open / Direct Acting Positioner .....	37
Air to Open / Reverse Acting Positioner .....	37
Air to Close / Direct Acting Positioner .....	38

- Air to Close / Reverse Acting Positioner.....38
- Field Mounting and Complete Calibration, Rotary Actuators** .....39
  - Air to Open / Direct Acting Positioner.....39
  - Air to Open / Reverse Acting Positioner.....39
  - Air to Close / Direct Acting Positioner.....40
  - Air to Close / Reverse Acting Positioner.....41
- Field Mounting and Complete Calibration Reciprocating Valves using 87/88 Actuators** 42
  - Air to Open / Direct Acting Positioner .....42
- Air to Open / Reverse Acting Positioner (4700P/4800P only)** .....42
  - Air to Close / Direct Acting Positioner.....43
- Air to Close/Reverse Acting Positioner (4700P/4800P only)** .....43
  - Damping Adjustment .....44
- Positioner Action Change (4700P/4800P Only)** .....45
  - From Air to Open / Direct to Air to Open/Reverse .....45
  - From Air to Open / Reverse to Air to Open/Direct .....45
  - From Air to Close / Direct to Air to Close/Reverse .....45
  - From Air to Close / Reverse to Air to Close/Direct .....45
- Maintenance** .....46
  - Pilot .....46
  - Disassembly.....46
  - Reassembly.....46
- Body** .....47
  - Disassembly .....47
  - Reassembly.....48
  - Diaphragm.....48
  - I/P Module .....48
- Bypass Valve Option (4700P Only)** .....49
  - Assembly to Positioner .....49
  - Disassembly.....49
- Troubleshooting** .....50
- Split Range Operation - 4700P/4800P** .....51
- Cam Lobe Selection and Lever Arm Orientation**.....52-54
- Parts Reference 4700P/4800P 3-15 and 6-30 Range** .....55
- Parts Reference 4700E/4800E** .....57
- Parts Reference** .....59
- Specifications** .....60
- Drawings** .....61

# Figures

Figure 1 - Numbering System.....	10
Figure 2 - Cover Removal .....	13
Figure 3 - Rotary.....	14
Figure 4 - Reciprocating .....	14
Figure 5 - 87/88 Actuator .....	15
Figure 5 - 87/88 Actuator.....	16
Figure 6 - 87/88 Actuator: Bracket Mounting Travel Settings .....	18
Figure 7 - Camflex II .....	20
Figure 8 - MiniTork II .....	20
Figure 9 - 39000 Series High Performance Butterfly Valve .....	20
Figure 10 - Pneumatic Installation .....	23
Figure 11 - Electrical Connections.....	24
Figure 12 - US/NEC Installation .....	29
Figure 13 - Canadian/CEC Installation .....	30
Figure 14 - ATEX Installation .....	31
Figure 15 - Split Range .....	31
Figure 16 - Lobe Identification .....	33
Figure 17 - Pilot Assembly.....	49
Figure 18 - 4700P/4800P 3-15 and 6-30 Ranges.....	55
Figure 19 - 4700E/4800E .....	57
Figure 20 - Bypass Option (4700 only).....	59
Figure 21 - Positioner and Cast Body Assembly .....	61

# Tables

Table 1 - Mounting Parts Reference 87/88 .....	15
Table 2 - Mounting Parts Reference .....	19
Table 3 - Split Range Operation.....	51
Table 5 - Parts Reference 4700E/4800E .....	58
Table 6 - Specification Data .....	60

# Safety Information

This section provides safety information and defines the documentation safety symbols.

## CAUTION



Read this entire section before installation and operation.

## Safety Symbols

4700/4800 instructions contain WARNINGS, CAUTIONS labels and Notes, where necessary, to alert you to safety related or other important information. Total compliance with all WARNING, and CAUTION notices is required for safe operation.

### WARNING



*Indicates a potentially hazardous situation, which if not avoided could result in serious injury or death.*

### CAUTION



*Indicates a situation, which if not avoided could result in property or data damage.*

### NOTE



*Indicates important facts and conditions.*

# 4700P/4700E and 4800P/4800E Product Safety

The 4700/4800 are intended for use with industrial compressed air or, natural gas systems only.

## NOTE



*Installations using natural gas are Zone 0 or Div 1 installations.*

Ensure that an adequate pressure relief provision is installed when the application of system supply pressure could cause peripheral equipment to malfunction. Installation must be in accordance with local and national compressed air and instrumentation codes.

## General installation, maintenance or replacement

- Products must be installed in compliance with all local and national codes and standards by qualified personnel using safe site work practices. Personal Protective Equipment (PPE) must be used per safe site work practices.
- Ensure proper use of fall protection when working at heights, per safe site work practices. Use appropriate safety equipment and practices to prevent the dropping of tools or equipment during installation.
- All surrounding pipe lines must be thoroughly flushed to ensure all entrained debris has been removed from the system.

## Hazardous Area Installation

- Products certified as explosion proof or flame proof equipment or for use in intrinsically safe installations **MUST BE**:
- Installed, put into service, used and maintained in compliance with national and local regulations and in accordance with the recommendations contained in the relevant standards concerning potentially explosive atmospheres.
- Used only in situations that comply with the certification conditions shown in this document and after verification of their compatibility with the zone of intended use and the permitted maximum ambient temperature.
- Installed, put into service and maintained by qualified and competent professionals who have undergone suitable training for instrumentation used in areas with potentially explosive atmospheres.



## WARNING



*Before using these products with fluids/compressed gases other than air or for non-industrial applications, consult the factory or local representative. This product is not intended for use in life support systems.*

## WARNING



*Under certain operating conditions, the use of damaged instruments could cause a degradation of the performance of the system, which can lead to personal injury or death.*

*Installation in poorly ventilated confined areas, with any potential of gases other than oxygen being present, can lead to a risk of personnel asphyxiation.*

Use only genuine replacement parts which are provided by the manufacturer, to guarantee that the products comply with the essential safety requirements of the European Directives.

Changes to specifications, structure, and components used may not lead to the revision of this manual unless such changes affect the function and performance of the product.

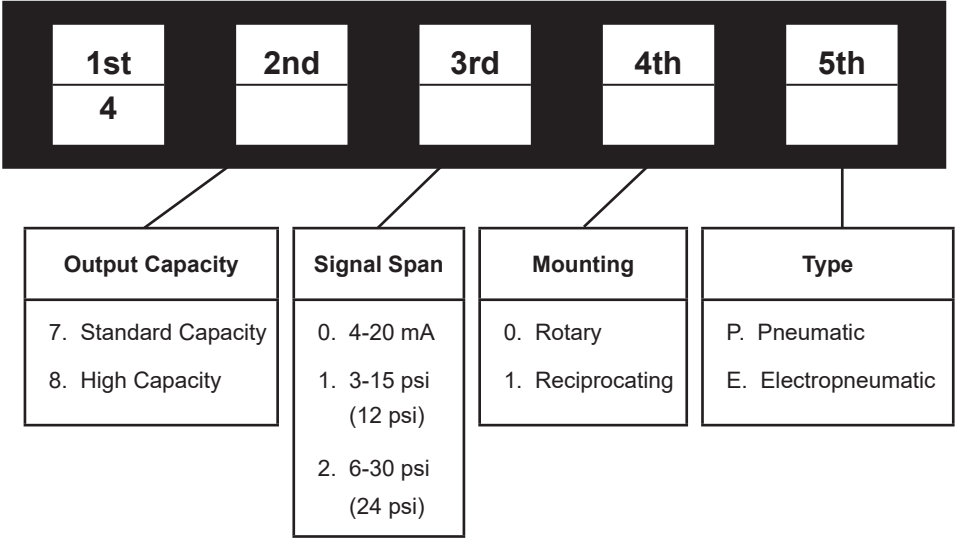
# Introduction

## General Description and Operation

The 4700P/4700E and 4800P/4800E positioners function to make a valve stroke proportional to a pneumatic or electrical control signal from a controller, or to modify the natural flow characteristic of the valve itself through the use of a characterized cam. They can be configured to provide split-ranging of valves and may be used with supplemental air supplies to achieve greater valve pressure drop. The 4700P/4800P pneumatic positioner can also be configured to reverse valve response to a control signal (control signal can either open or close the valve). The 4700E/4800E electropneumatic positioner is not available with reverse action.

The Model 4700P/4700E and 4800P/4800E pneumatic positioner design is based on the force-balance principle: the signal pressure exerted on a diaphragm is opposed by a feedback spring. In the balanced state, when the pneumatic signal varies, the diaphragm assembly moves. This movement is followed by the pilot plug which is opposed by the pilot spring.

Movement of the pilot plug alternately connects the output circuit to the supply circuit or the exhaust port, thus modifying air pressure to the actuator. The cam transmits the valve plug movement to the feedback spring. The valve plug continues to move until the spring force exactly balances the force of the instrument signal on the diaphragm. In the new balanced state, the valve plug is positioned in a programmed relationship to the instrument signal.



**Figure 1 - Numbering System**

# Pilot

The pilot is essentially a three-way sliding valve. The plug regulates supply air flow to and from the actuator to the exhaust port. The position of this plug, governed by the diaphragm, determines the output pressure of the positioner. The 4700P/4800P pneumatic positioner action may be reversed by interchanging the supply and exhaust connections and changing cam lobe and lever arm orientation.

## Direct Action

Increasing instrument signal pressure produces an increase in output pressure.

## Reverse Action

Increasing instrument signal pressure produces a decrease in output pressure.

## Cam

The cam is the intermediate element in the feedback mechanism between the actuator and the feedback spring. Its profile determines the relationship between the valve plug position and the control signal. *Linear*, *Split Linear*, or *Percentage Control* characteristics are available by selection of proper lobe on cams supplied for Camflex™ II and 87/88 actuators. Cams supplied on butterfly valves maintain the inherent valve characteristic. Custom characteristics are available on special order.

## Optional Bypass Valve (4700P, Direct Acting Model only)

During normal operation, the instrument signal is applied directly to the positioner diaphragm and the regulated supply pressure flows through the pilot valve to or from the actuator.

The bypass valve module permits the positioner to be isolated for maintenance while operating the valve directly with the instrument signal. By turning the nylon bypass valve to the bypass position (the raised arrow on the bypass valve aligned with the word Bypass on the face positioner body indicates this position), the normal positioner output pressure to the actuator is blocked and the instrument signal is applied both to the positioner diaphragm and the actuator. The bypass valve does not block supply pressure to the pilot. Therefore, the supply line should be shut off before disassembling the positioner.

### WARNING



*When a valve (because of high pressure drop) uses a supply pressure higher than 20 psig, the 3-15 psig instrument signal may not be sufficient to operate the valve when the positioner is bypassed. Moreover, if the positioner with a high supply pressure is bypassed suddenly, the high pressure in the actuator may damage the diaphragm and/or the control instrument. Therefore, the bypass valve should be used only if the positioner supply pressure is 20 psig (140 kPa or 1, 4 bar), or at most 35 psig (240 kPa, or 2, 4 bar), or if the controller is capable of operating the valve directly. When bypassing a positioner, ensure that the controller output is equal to supply required to operate the valve.*

# Installation

## Mounting and Orientation

The valve is installed in the pipeline to operate in one of two ways:

Air to Open	Air to Close
Close on air failure	Open on air failure
Reverse Action	Direct Action

The choice depends on the desired air failure action. This subject is dealt with in separate actuator instructions. The positioner can operate either by direct action (increasing instrument signal produces an increase in output pressure) or reverse action (increasing instrument signal produces a decrease in output pressure). See Figure 3 and Figure 4.

### CAUTION



*When installing a positioner on a valve, it is necessary to choose the proper valve action and positioner action. It is absolutely necessary to place valve travel at the point corresponding to the low end of the signal range when removing or installing a cam. At this point, feedback spring compression is at lowest value and will facilitate cam removal or installation. Prior to performing any work, read and understand "General Description and Operation" on page 10 and Installation2. Define the scope of work to be performed and find the appropriate section that should be followed.*

### NOTE



*The 4700E/4800E is not available with reverse action, hence if the application demands an electropneumatic positioner and reverse action, a 4700P/4800P with external I/P transducer is required.*

The 4700 Series positioners have the same mounting and linkage attachment dimensions as the 4600, 4600A, 4600B and 4700B Series positioners but have a different layout of pneumatic connections. They can replace the older models if operational requirements are identical and pneumatic connections are changed. The mounting details in this instruction cover only the more widely used valves and actuators.

# Cover Removal

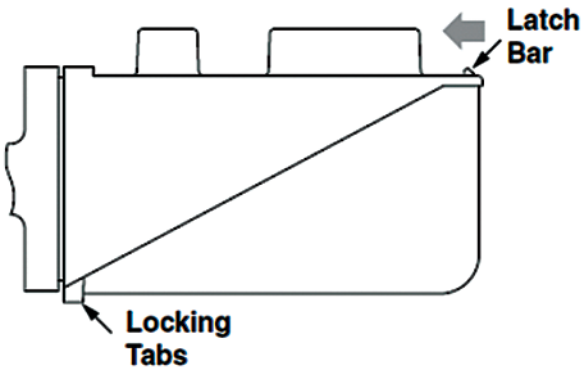
The snap-on cover must be removed to access the zero and span adjustments and to mount the positioner on the valve.

## Plastic cover

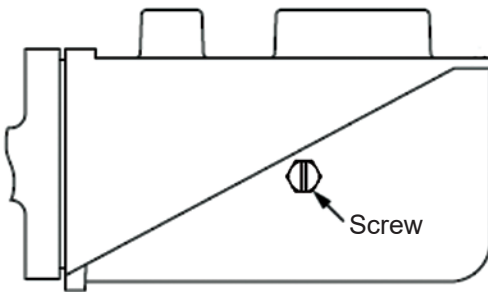
To remove the cover, press the latch bar inward as shown in Figure 2 below, pull cover away from body until latch tab is clear, then pull along body axis to free the two top locking tabs.

## Metal cover

To remove the cover, unscrew the two screws on each side, one side shown in Figure 2 below.

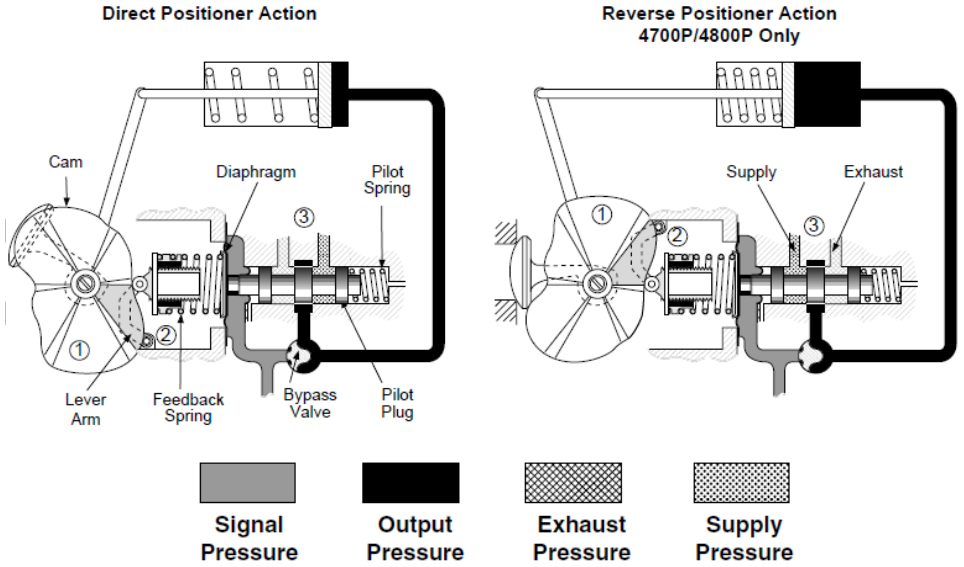


Plastic Cover

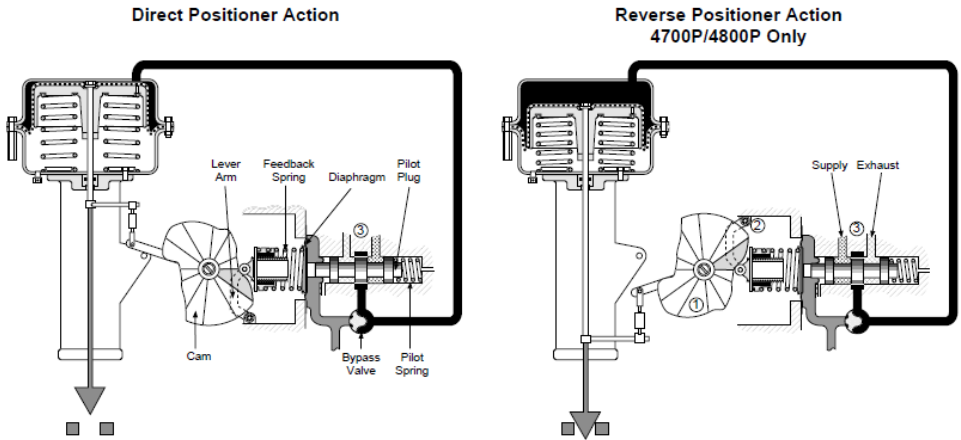


Metal Cover

**Figure 2 - Cover Removal**



**Figure 3 - Rotary**



**Figure 4 - Reciprocating**

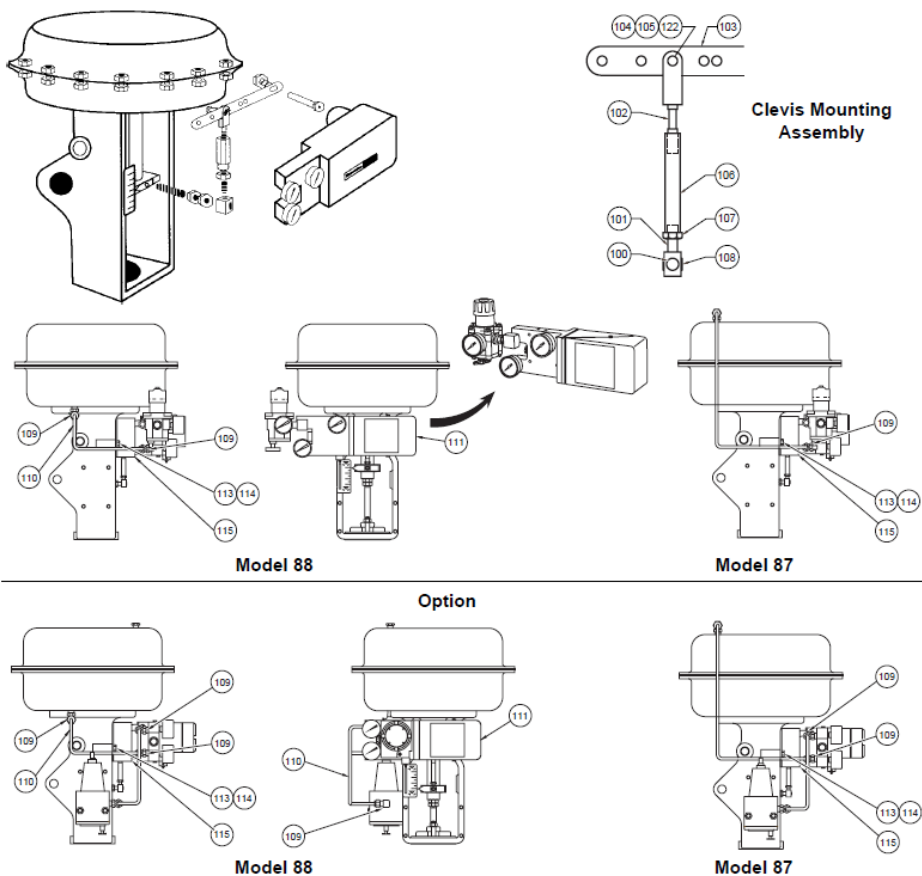
For 4700P/4800P model only, positioner action can be reversed by simply engaging the proper lobe on the cam and reversing the follower arm (numbers 1 and 2 above), and the supply and exhaust ports (number 3 above).

# 87/88 Actuator

**Table 1 - Mounting Parts Reference 87/88**

Ref. No.	Description	Ref. No.	Description	Ref. No.	Description
100	Clamp Rod	110 <sup>(1)</sup>	Tubing	29	Screw,,312-18 x 1.25
101	Turnbuckle Screw	111	Positioner	30	Washer, Shakeproof
102	Clevis	112 <sup>(1)</sup>	Male Connector	37	Ring, Retaining
103	Back Lever	113	Cap Screw	38	Cap Screw
104	Clevis Pin	114	Lockwasher	39	Lockwasher
105	Retaining Clip	115	Mounting Bracket	40	Washer,,531 ID
106	Turnbuckle	122	Washer	41	Post Hub
107	Locknut	26	Cam	42	Input Shaft
108	Locknut	27	Washer	51	Lockwasher
109 <sup>(1)</sup>	Elbow	28	Pan Head Screw	135	Instruction Plate

1. Not included in the mounting kit.



**Figure 5 - 87/88 Actuator**



# Mounting 4700P and 4700E on Series 87/88 Actuators

1. Using screws (113) and lockwashers (114), mount bracket (115) on actuator with opening located to the right side of the bracket (Air to Open).
2. Install input shaft (42) in post hub with a washer (40) on each side of the hub and retaining ring (37) on cam end.
3. Mount back lever (103) to input shaft using screw (38) and lockwasher (39).
4. Install clevis (102), clevis pin (104), washer (122), and retaining clip (105) in the proper location on the back lever. Location is based on valve stroke required.
5. Check Figure 6 for proper mounting location for positioner on bracket.
6. Mount positioner on bracket using socket head screws (29) and lockwashers (30).

## NOTE



*Back lever must be behind bracket.*

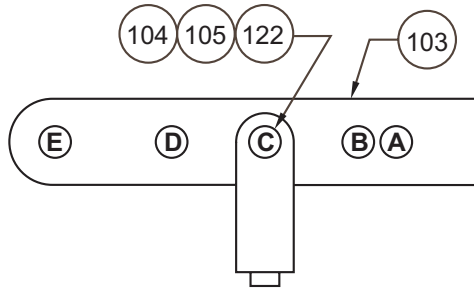
7. Mount cam (26) on input shaft using washer (27), lockwasher (51) and screw (28) with desired lobe against cam follower. (Do not mount cam if positioner is reverse action).
8. Connect turnbuckle (106), locknut (107), turnbuckle screw (101), locknut (108), and clamp rod (100).

Model	Travel (mm)	Travel (in.)	Hole Location
4700	20.3	0.8	A
4700	25.4	1.0	B
4700/4800	38.1	1.5	C
4700/4800	50.8	2.0	D
4700/4800	63.5	2.5	E

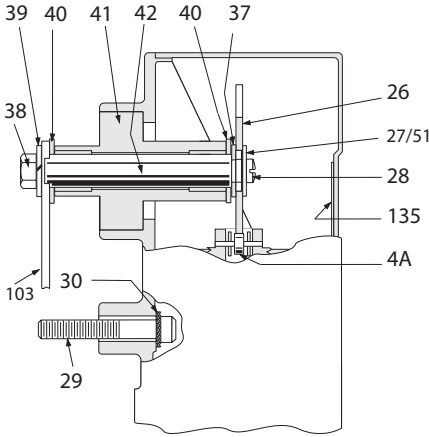
## NOTE



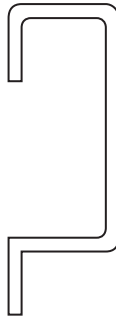
*Strokes shorter than 20.3 mm (0.8"), require a special mounting kit. Consult factory.*



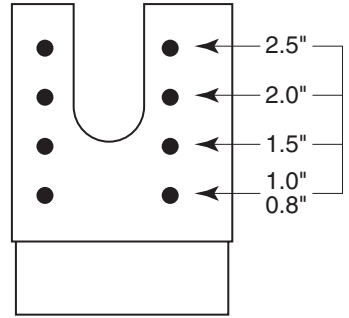
**Back Lever**



**Top view of 4700P/4700E and  
4800P/4800E Positioner**



**Side view of  
Bracket**



**Front view of  
Bracket (115)**

**Figure 6 - 87/88 Actuator: Bracket Mounting Travel Settings**

# Positioner Mounting and Orientation

## Camflex™ II, V-Max™, MiniTork™ II, and Butterfly

The positioner is mounted to an intermediate plate (171) by two screws (29) and lockwashers (30) with the gauges nearest the actuator on Camflex (Figure 7) and with gauges away from actuator on MiniTork II (Figure 8), and HPBV 39004 (Figure 9). The intermediate mounting plate (171) is held by two flat-head screws (172) to the bracket.

### NOTE



*The cam take-off hole must be centered on the shaft.*

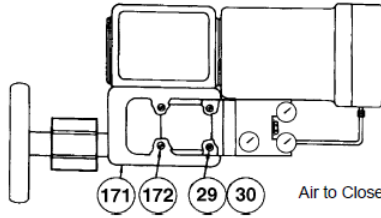
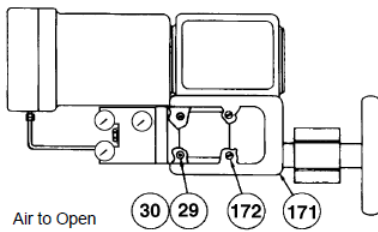
**Table 2 - Mounting Parts Reference**

Ref. No.	Description	Ref. No.	Description
29	Socket Head Screw	172	Mounting Plate Screws
171	Mounting Plate	30	Lockwashers

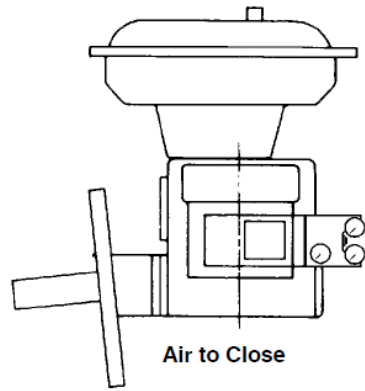
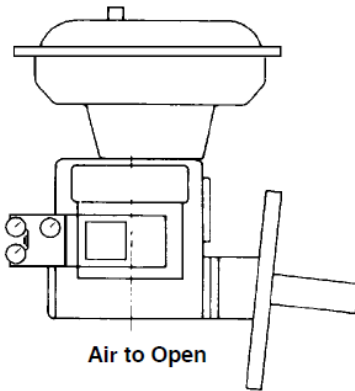
### NOTE



*The remainder of the mounting kit parts are used to before tightening mounting screws. assemble the cam to the actuator. See "Mounting Cam Coupling" on page 34.*

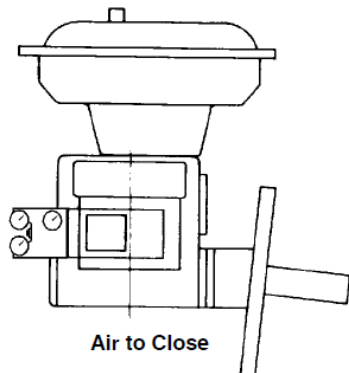
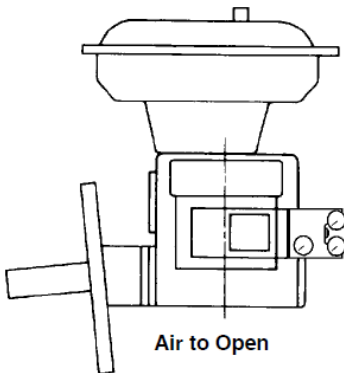


**Figure 7 - Camflex II**



**Figure 8 - MiniTork II**

(Refer to Figure 7 for details on positioner mounting parts)



**Figure 9 - 39000 Series High Performance Butterfly Valve**

(Refer to Figure 7 for details on positioner mounting parts)

# Pneumatic Installation

## NOTE



*The output and supply connections for the 4700E/P and 4800E/P are different from those on the 4600A. Refer to “Mounting Cam Coupling” on page 34.*

These positioners are designed to operate only with clean, dry, oil-free, instrument grade air to ASME/ASA-57.3 1975 (R1981) or ISA-S7.3-1075 (R1981).

Dew point	At least 18 °F (10 °C) below minimum anticipated ambient temperature
Particulate matter	Filtered to below 5 microns
Oil content	Less than 1 ppm w/w or v/v
Contaminants	Free of all corrosive contaminants and hazardous gases, flammable or toxic

The signal connections of 4700P and 4800P and the output and supply connections of 4700P and 4700E are tapped 1/4" NPT. The output and supply connections of 4800P and 4800E are tapped 3/8" NPT. There is also an exhaust connection with a plastic square head plug in it. If the action of the positioner is reversed, 4700P/4800P only, then the supply and exhaust connections must be interchanged. With reverse action, the supply gauge must be removed and replaced by an 1/8" NPT plug installed in the supply connection. Since the new supply connection has no gauge port, connect the removed supply gauge to the filter regulator to indicate regulator output pressure.

Figure 10 on page 23 shows pneumatic connections for both 4700P/4800P and 4700E/4800E positioners. The 4700E/4800E has the instrument port sealed by a 1/4" NPT plug. Do not remove plug or make any other connections to this port.

The use of a filter regulator with a 5 micron filter is recommended for the air supply. Tubing used for piping between filter regulator, positioner, and actuator should be 1/4" minimum, with 3/8" used for larger actuators with 4700P/4800E positioner.

## WARNING



*Never exceed actuator or positioner maximum supply pressure. Damage to equipment or injury to personnel may result.*

## CAUTION



*Do not use pipe thread sealant tapes on pneumatic fittings, as it tends to shred small particles which can cause instrument malfunction.*

*The use of soft setting anaerobic hydraulic seal, such as Loctite Hydraulic Seal 542, is recommended. Follow manufacturer's instructions.*

## CAUTION

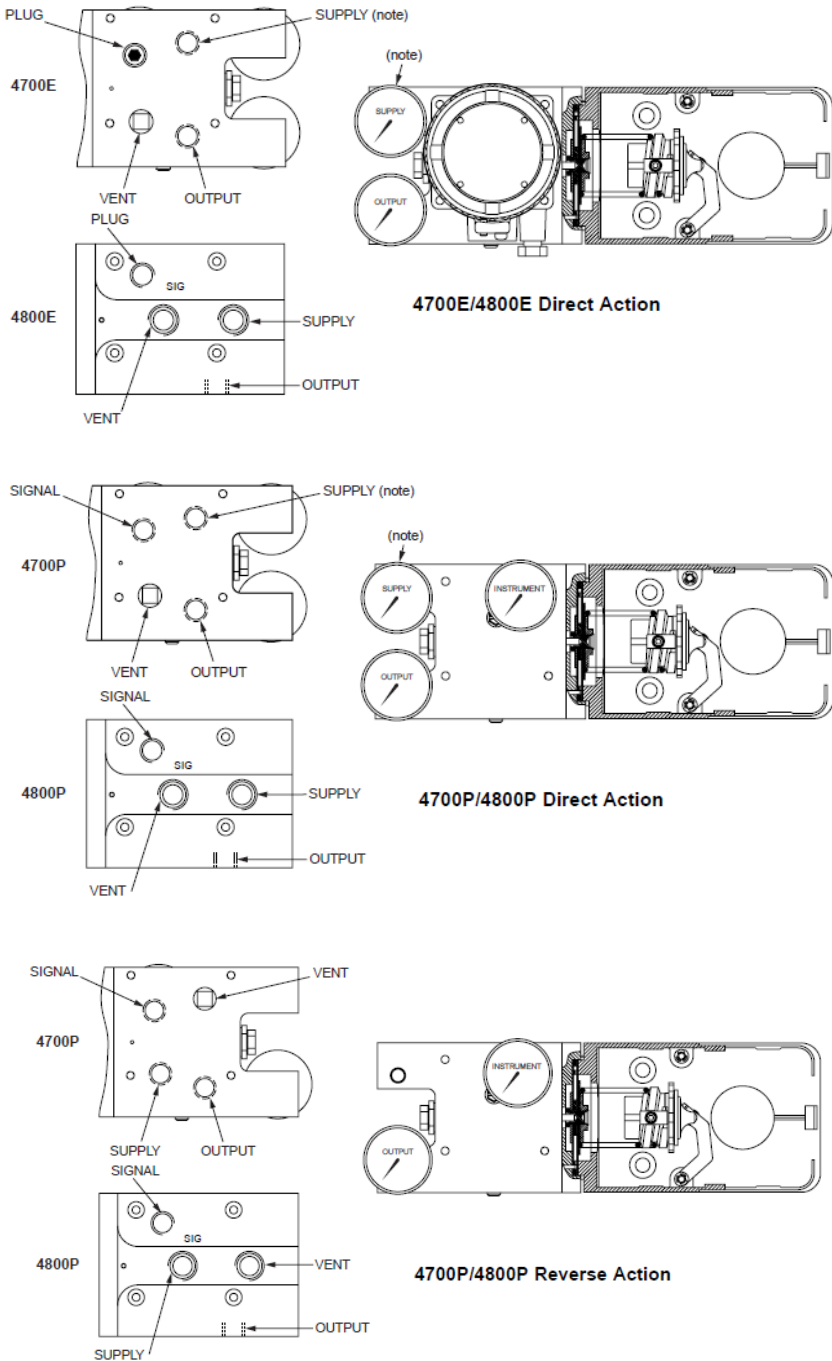


*Do not use an excessive amount, as it will not set and may migrate into the instrument.*

*The pneumatic input signal ranges are 3-15 psig (20-100 kPa or 207- 1034 mbar), 6-30 psig (40-200 kPa or 414-2068 mbar), and 3-27 psig (20-180 kPa or 207-1862 mbar). Split ranges are available.*

*Positioners with 24 psig signal span (i.e., 6-30 psig and 3-27 psig) require a different diaphragm assembly as shown in Figure 18 on page 56.*

*Maximum allowable air supply pressure to the positioner varies according to actuator, valve size, and type. See pressure drop tables in valve catalog to determine correct positioner supply pressure.*



**Figure 10 - Pneumatic Installation**

# Electrical Installation of 4700E/4800E

Electrical connections should be made as shown in Figure 11. The terminals will accept wire sizes up to AWG 14.

The loop controller driving the positioner must be able to supply 4-20 mA with an output voltage compliance of 5 VDC minimum.

The available output voltage of a current source is reduced by loop wiring resistance. This can be checked by connecting a resistor of value (250 Ohms + loop resistance) across the output of the controller and verifying that at 100%, controller output 20 mA can be reached.

## CAUTION



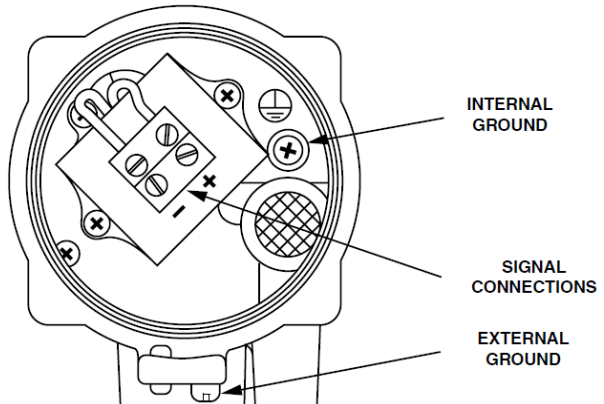
*Do not use a voltage source to drive the positioner as it may cause permanent damage.*

## CAUTION



*The positioner must be installed in accordance with local and national codes of practice in both general purpose and hazardous area locations. The electrical components are fully isolated from ground and therefore grounding is unnecessary for functional purposes. Grounding may be necessary to conform to installation codes.*

*The positioner is normally supplied with a 1/2" NPT conduit entry (M20 is optional). Internal and external ground terminals are provided for use if grounding is required.*



**Figure 11 - Electrical Connections**



# Hazardous Area Installations

The positioner is available in versions suitable for use in hazardous areas. The labeling on the positioner indicates correct areas of use.

## WARNING



*Installation of any hazardous area equipment must be made in accordance with the appropriate hazardous area installation codes and the manufacturer's installation and operating instructions.*

*You must make no changes or attempt any repairs of a certified instrument since this invalidates the certified design. If a certified instrument should fail it must be returned to the manufacturer for repair.*

*Maximum pressure 100 psi.*

## WARNING



*Under certain circumstances, non-metallic parts may generate an ignition-capable level of electrostatic charge. To avoid the risk from electrostatic discharge and safe operation, a damp cloth shall only be used when cleaning or wiping the device. Cleaning must only be done when local conditions around the device are free of potentially explosive atmospheres. Do not use a dry cloth or any solvents.*

## US and Canadian Standards



### Conform to US standards:

- 3600, 3610, 3611, 3615

**Intertek**

### Certified to Canadian standards:

- C22.2 No. 157, 30, 25, 213

5030188

# US/NEC Approvals

## WARNING



*Substitution of components may impair intrinsic safety.*

### Explosion proof:

Class I, Division 1, Groups B, C, and D.

Temperature classification T6 @ 75°C ambient, T5 @ 85°C ambient, indoor and outdoor (NEMA Type 4X) hazardous (classified) locations.

$12\text{ V} \leq V_{\text{max}} \leq 30\text{ V}$ ,  $I_{\text{max}} = 96\text{ mA}$ ,  $C_i = 0\text{ }\mu\text{F}$ ,  $L_i = 3.7\text{ mH}$

## WARNING



*Do not open when an explosive gas atmosphere is present.*

### Dust-Ignition proof:

Class II / III, Division 1, Groups E, F, and G.

Temperature classification: T6 @ 75°C ambient, T5 @ 85°C ambient.

Max. power = 0.8 W. Ambient temperature: -40°C to +85°C.

Install as per drawing 1997-155 (Figure 21 on page 62).

### Non-incendive:

Class I, Division 2 Groups A, B, C, and D; S: Class II and III, Division 2 Groups F and G.

Temperature classification: T4 @ 40°C ambient, T3B @ 70°C ambient, T3A @ 85°C ambient.

Installation must be in accordance with the current edition of the National Electrical Code ASME / NFPA-70, any applicable local codes, and manufacturer's instructions.

### Intrinsically safe:

Class I / II / III, Division 1, Groups A, B, C, D, E, F, and G hazardous indoor/outdoor NEMA 4X locations.

Temperature Classification T4 @ 40°C ambient, T3B @ 70°C ambient, T3A @ 85°C ambient.

Installation must be in accordance with the current edition of the National Electrical Code ASME / NFPA-70, ASME / ISA RP 12.6 "Installation of Intrinsically Safe Instrument Systems in Class I Hazardous (Classified) Locations". Install as per drawing 96-115 (Figure 12 on page 30) and manufacturer's instructions.

# Canadian/CEC Approvals

## WARNING



*Substitution of components may impair intrinsic safety/Div 2 suitability.*

**Explosion proof:** Class I, Division 1, Groups B, C, and D Class II, Groups E, F, and G and Class III rated at 30 mA maximum, 28 VDC maximum, with a temperature code T6 @ 75°C, T5 @ 85°C, Type 4X enclosure.

**Non-incendive:** Class 1, Division 2, Groups A, B, C, and D, with a temperature code T6 @ 75°C, T5 @ 85°C.  
Install as per drawing 1997-155 (Figure 21 on page 62).  
Installation must be in accordance with the current edition of the Canadian National Electrical Code Part I, any applicable local codes and manufacturer's instructions.

**Intrinsically safe:** Class I, Division 1, Groups A, B, C, and D, Class II, Groups E, F, and G, Class III rated at 30 mA maximum 28 VDC maximum. Temperature code T6 @ 55°C, T4A @ 85°C, Type 4X enclosure.  
Installation must be in accordance with the current edition of the Canadian National Electrical Code Part I. Install as per drawing 96-112 (Figure 13 on page 31) and manufacturer's instructions.

# ATEX Approvals

Installation must be in accordance with current applicable country codes and manufacturer's instructions.

Maximum pressure 100 psi.

## Intrinsically safe:

Installation must be in accordance with current editions of applicable country codes, Figure 14 on page 32, and manufacturer's instructions. Housing protection rating IP 66.

## WARNING



*Do not open when energized. Do not open when an explosive gas atmosphere is present. Use cables rated to  $\geq 5^{\circ}\text{C}$  above ambient.*

## For flame proof (Ex d protection concept):

The marking of the equipment shall include the following:



ITS-I21ATEX29368X

II 2GD

Ex db h IIC T6 Gb  $T_a = -40^{\circ}\text{C}$  to  $+55^{\circ}\text{C}$

Ex db h IIC T5 Gb  $T_a = -40^{\circ}\text{C}$  to  $+70^{\circ}\text{C}$

Ex db h IIC T4 Gb  $T_a = -40^{\circ}\text{C}$  to  $+85^{\circ}\text{C}$

Ex tb IIIC T90° Db  $T_a = -40^{\circ}\text{C}$  to  $+55^{\circ}\text{C}$

$P_i = 0.8\text{W}$

## For intrinsically safe (Ex ia protection concept):

The marking of the equipment shall include the following:



ITS-I21ATEX29368X

II 1GD

Ex ia h IIC T4 Ga  $T_a = -40^{\circ}\text{C}$  to  $+80^{\circ}\text{C}$ ,  $P_i = 1.1\text{ W}$

Ex ia h IIC T6 Ga  $T_a = -40^{\circ}\text{C}$  to  $+55^{\circ}\text{C}$ ,  $P_i = 0.33\text{ W}$

Ex ia h IIIC Da T90°C  $T_a = -40^{\circ}\text{C}$  to  $+80^{\circ}\text{C}$ ,  $P_i = 1.1\text{ W}$

Special Conditions for Safe Use (denoted by "X" after the certificate number)

This enclosure is made from light metal which could cause ignition due to impact. This shall be taken into consideration when the apparatus is installed in locations that specifically require *Equipment Protection Levels* Ga or Da.

If the Model 4000 I/P Converter is mounted with the axis of the plastic baffle in the vertical position with the baffle uppermost. Therefore, the required ingress protection against water is invalidated; it shall only be installed in this orientation if its location provides protection against falling water.

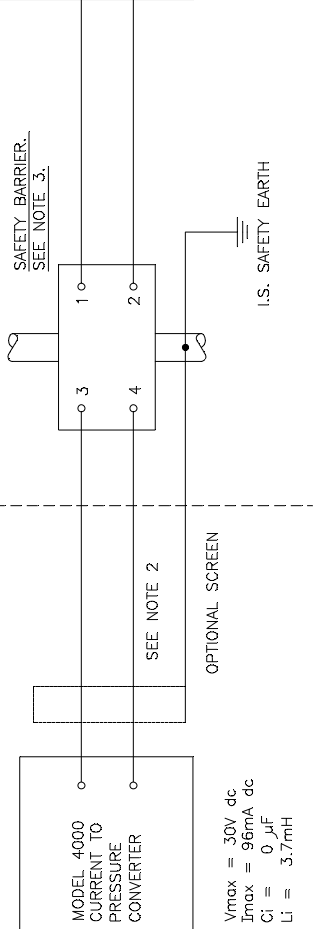
00 NOT SCALE DRAWING, IF IN DOUBT ASK.

96-115 ISSUE 'B'-FM IS SYSTEM

HAZARDOUS LOCATION  
CLASS 1 DIVISION 1 GROUPS A,B,C AND D

NON-HAZARDOUS LOCATION

NON-HAZARDOUS LOCATION  
UNSPECIFIED EXCEPT THAT IT MUST NOT BE SUPPLIED FROM NOR CONTAIN UNDER NORMAL OR ABNORMAL CONDITIONS A SOURCE OF POTENTIAL WITH RESPECT TO EARTH IN EXCESS OF 250 VOLTS RMS OR 250V DC



**FM**  
**CERTIFIED PRODUCT**  
No modifications are permitted without reference to FMRC.

**NOTES**

1. THE ELECTRICAL CIRCUIT IN THE HAZARDOUS AREA MUST BE CAPABLE OF WITHSTANDING AN A.C. TEST VOLTAGE OF 500 VOLTS R.M.S. TO EARTH OR FRAME OF THE APPARATUS FOR 1 MINUTE.

2. CABLE CAPACITANCE AND INDUCTANCE PLUS THE U.S. APPARATUS UNPROTECTED CAPACITANCE (Ci) AND INDUCTANCE (Li) MUST NOT EXCEED THE ALLOWED CAPACITANCE (Co) AND INDUCTANCE (Lo) INDICATED ON THE ASSOCIATED APPARATUS.

3. ANY POSITIVE POLARITY SAFETY BARRIER APPROVED BY FMRC FOR GROUPS A,B,C AND D WHOSE OUTPUT PARAMETERS ARE :-

$V_{oc}$  or  $V_t \leq 12V$  and  $\leq 30V$   
 $I_{sc}$  or  $I_t \leq 96mA$   
 $P_{max} \leq 0.8W$   
eg. MTL 728, P & F Z428/Ex

THE OUTPUT CURRENT MUST BE LIMITED BY A RESISTOR R SUCH THAT  $R \geq V_{oc} / I_{sc}$

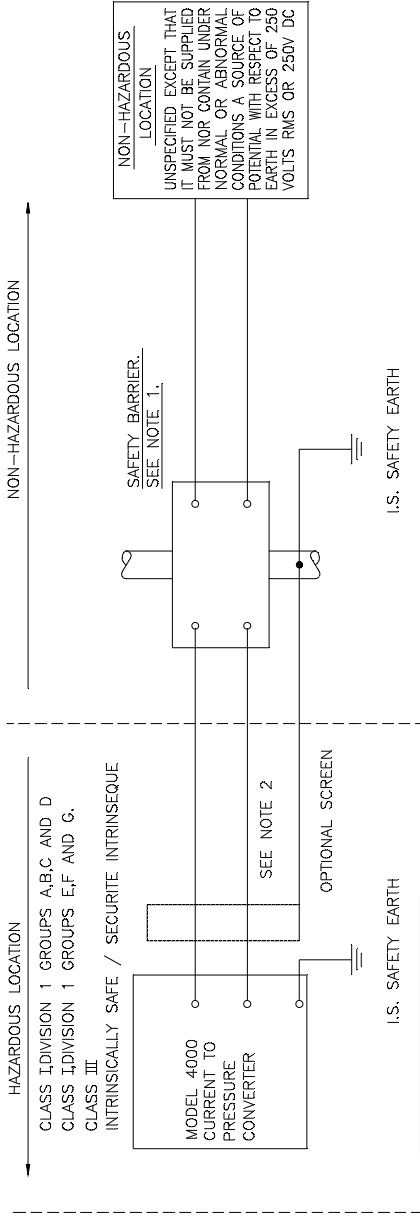
4. THE INSTALLATION INCLUDING THE BARRIER EARTHING ARRANGEMENTS MUST COMPLY WITH THE INSTALLATION REQUIREMENTS OF THE COUNTRY OF USE, ie ANSI/ISA RP12.6 (INSTALLATION OF INTRINSICALLY SAFE SYSTEMS FOR HAZARDOUS (CLASSIFIED) LOCATIONS) AND THE NATIONAL ELECTRICAL CODE. INSTALLATION MUST BE IN ACCORDANCE WITH THE MANUFACTURERS GUIDELINES.

B A	3084	11-7-86 20-5-86	ISS NO.	DATE	ISS NO.	DATE	WHERE USED	UNLESS OTHERWISE STATED	SURFACE FINISH $\nabla$	REMOVAL BURRS & SHARP ANGLES $\nabla$	X.X ± 0.25mm	X.X ± 0.15mm	X ± 0.25mm	X ± 0.15mm	CHECKED MATKINSON	APPROVED	MATERIAL	 WATSON SMITH LTD 10000 S. DUNCAN LANE ST. BELLEVILLE, ILLINOIS 62220 TEL: 314 245 7587 FAX: 314 245 7587 DOWN TO EARTH	MODEL 4000 MASSONELAN IS FM SYSTEM	T DISC	N.T.S. SCALE
																				96-115	96-115

**Figure 12 - US/NEC Installation**

DO NOT SCALE DRAWING, IF IN DOUBT ASK.

96-112 ISSUE 'C' - CSA IS SYSTEM



NON-HAZARDOUS LOCATION  
UNSPECIFIED EXCEPT THAT IT MUST NOT BE SUPPLIED FROM NOR CONTAIN UNDER NORMAL OR ABNORMAL CONDITIONS A SOURCE OF POTENTIAL WITH RESPECT TO EARTH IN EXCESS OF 250 VOLTS RMS OR 250V DC

NON-HAZARDOUS LOCATION

HAZARDOUS LOCATION

CLASS I DIVISION 1 GROUPS A,B,C AND D  
CLASS I DIVISION 1 GROUPS E,F AND G,  
CLASS III  
INTRINSICALLY SAFE / SECURITE INTRINSEQUE

MODEL 4000  
CURRENT TO  
PRESSURE  
CONVERTER

SEE NOTE 2

OPTIONAL SCREEN

SAFETY BARRIER.  
SEE NOTE 1.

I.S. SAFETY EARTH

I.S. SAFETY EARTH

TEMPERATURE CODE	AMBIENT (MAX)
T4A	85°C
T6	55°C

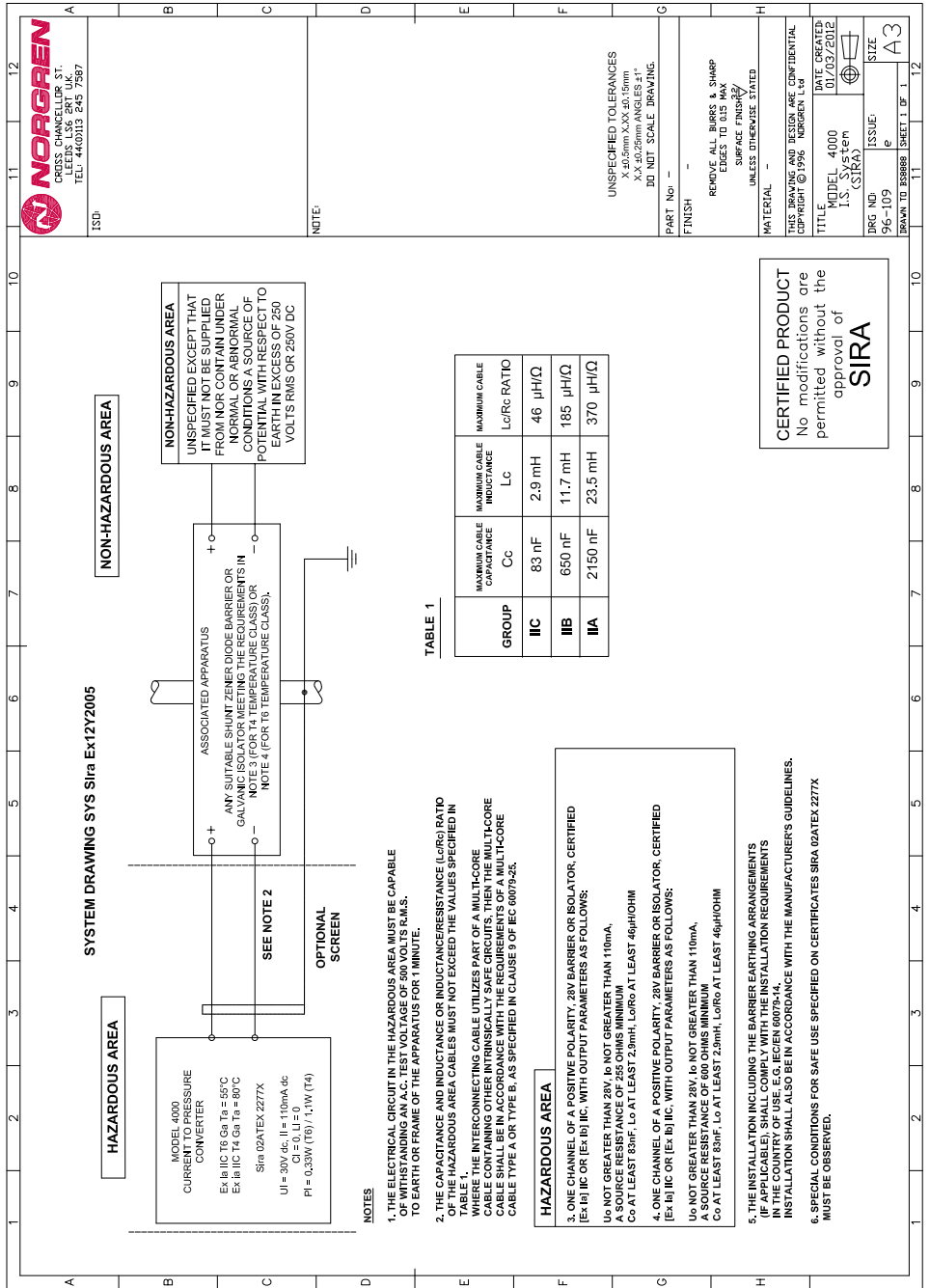
NOTES

- ANY POSITIVE POLARITY SAFETY BARRIER APPROVED BY C.S.A. FOR GROUPS A,B,C AND D WHOSE OUTPUT PARAMETERS ARE :-  
28V (max)  
300 Ohms (min)  
eg. MTL 728 +  
P & F Z428/Ex
- THE INSTALLATION INCLUDING THE BARRIER EARTHING ARRANGEMENTS MUST COMPLY WITH THE CANADIAN ELECTRICAL CODE PART I.

**C.S.A.**  
**CERTIFIED PRODUCT**  
No modifications are permitted without reference to C.S.A.

ISS. NO.	DATE	ISS. NO.	DATE	WHERE USED	CHECKED	APPROVED	MATERIAL	DATE APPROVED	FINISH	TITLE	T. DISC	N.T.S. SCALE
C 306A	27-08 27-08				MATKINSON					MODEL 4000 MASONELIAN IS C.S.A. SYSTEM		
A	20-5-96									WATSON SMITH LTD SUITE 2000, 1000 ST. JACQUES ST. MONTREAL, QUEBEC H3T 1S7 TEL: 514 245 7587 FAX: 514 245 7587 THIS DRAWING IS CONFIDENTIAL. COPYRIGHT © 1996 DRAWN BY: P. BLOIS		96-112 DRG. NO.

Figure 13 - Canadian/CEC Installation



**Figure 14 - ATEX Installation**

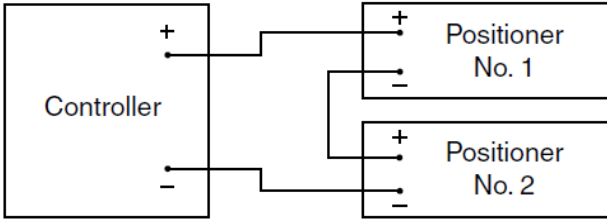
# Split Range Operation

Split ranging permits operation of two valves in sequence from one 4-20 mA control signal. To accomplish this with the 4700E/4800E, the two positioners are connected in series as shown in Figure 15, with the actual split ranging done by proper cam segment selection per tables in “Cam Lobe Selection and Lever Arm Orientation” on page 53.

## NOTE



*With this configuration, the voltage burden of the 4-20 mA controller is 10 V instead of 5 V.*



**Figure 15 - Split Range**



# Mounting Cam Coupling

See Figure 18 on page 56 and 19 on page 58.

The cam coupling (34), used on rotary actuators, is positioned on the shaft with the key engaged in the shaft slot and the set screws (35) to the top and side. The coupling hold-down screw (32) with the lockwasher (33) is torqued to 125 inch-lbs.

## Mounting Cam

The cam holder (36) and cam (26) are positioned on the cam coupling (34) so that the desired cam lobe's low signal line is properly adjusted on the cam follower (4A). Proper adjustment is achieved when:

The desired cam lobe's low signal line is in alignment with the raised reference line on the positioner (refer to Figure 18).

The cam is centered between the two arms of the cam lever S/A (3) (refer to Figure 18).

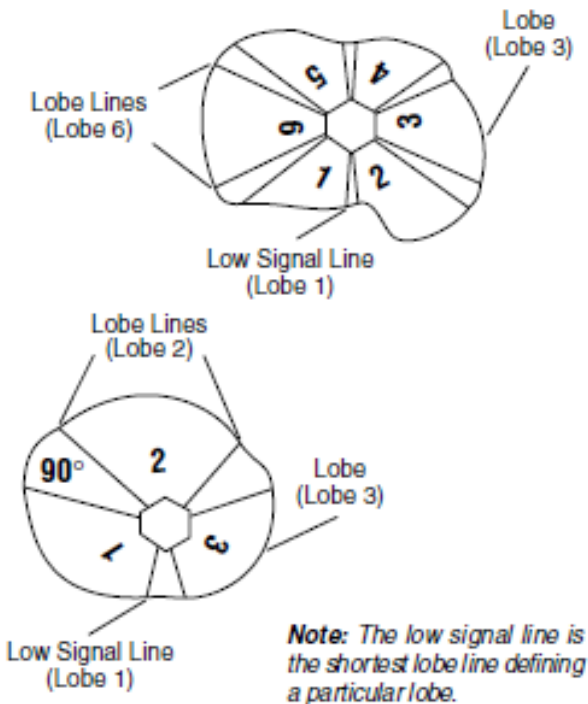


Figure 16 - Lobe Identification

## Lever Subassembly (S/A) Orientation

See “Field Mounting and Complete Calibration, Rotary Actuators” on page 40 and “Field Mounting and Complete Calibration Reciprocating Valves using 87/88 Actuators” on page 43.

The relative position of the lever S/A (3) for a selected cam lobe must be correct. The lever S/A can be mounted with its pivot post to the left or right of the cam center.

## Changing Lever Subassembly (S/A) Orientation

See “Field Mounting and Complete Calibration, Rotary Actuators” on page 54 and “Field Mounting and Complete Calibration Reciprocating Valves using 87/88 Actuators” on page 43.

If lever S/A (3) must be changed, remove screw (28), lockwasher (51) and washer (27), and cam (26) from cam shaft. Remove retaining ring (17) and flat washer (16). Remove lever S/A (3) from pivot post. Lift and rotate lever S/A (3) on spring end 180° to desired position. Do not rotate spring end, socket head screw on spring must face outward. Replace flat washer (16) and retaining ring (17) on pivot post.

# Calibration

## General

### WARNING



*Before starting any calibration or maintenance procedure on these positioners, ensure that the valves under control are isolated from the controlled process and that the area is verified as nonhazardous.*

The Model 4700P/4700E and 4800P/4800E positioner, when factory mounted, has been calibrated for the proper valve, valve action, and positioner action. If for any reason, the cam holder (36) setting has been disturbed (a change of positioner action, field mounting, maintenance, etc.), all steps of calibration instructions should be followed according to desired actuator action and positioner action.

For proper performance when the valve is installed, calibrate the positioner as part of the normal installation procedure. Shipping, handling and installation can cause some changes in the calibration.

Calibration may entail just a simple adjustment or a complete field mount. Define the scope of work and follow the applicable sections.

### CAUTION



*Do not attempt to remove cam if cam is not at low signal line of lobe (low end of range). Refer to calibration instructions for proper valve action and positioner action before removing or replacing cam and tightening set screws (35) to proper torque.*

## Zero Adjustment

See Figure 18 on page 56 and Figure 19 on page 58.

The zero adjustment is made with the zero nut (4B). When the positioner is installed and the pneumatic circuits are connected, apply low instrument signal (3 psi for 4700P/4800P and 4 mA for 4700E/4800E), release locknut (4C) and turn zero nut (4B) to adjust valve plug to proper position (open or closed). Then tighten zero lock nut (4C).

### NOTE



*Do not attempt to adjust zero nut with signal above low end of signal range. If the valve is seated at low end of signal range, after making zero adjustment, decrease signal below low end of signal range and slowly increase signal to ensure valve plug lifts off seat at desired signal. If the valve is open at low end of signal range, adjust zero until the valve indicates “open” on travel indicator scale.*

## Span Adjustment

See Figure 18 on page 56 and Figure 19 on page 58.

If the valve does not fully stroke for a full signal span, the feedback spring rate is too high. Loosen screw (8) and turn spring (5) on the spring end (4) to increase the number of active coils and decrease the spring rate. Conversely, if full stroke is reached prior to full signal span, turn the spring to decrease the number of active coils and increase the spring rate.

Adjustment of a quarter turn of the spring changes its rate by approximately ten percent.

After making a spring adjustment, it is necessary to reset the zero. This is achieved by turning the zero adjustment (4B), and tightening zero locknut (4C).

Example: If the number of active coils is increased making the spring longer, it is necessary to readjust the zero nut to compensate for the increased spring length.

When span adjustment has been completed, re-tighten the spring locking socket head screw (8).

### CAUTION



*When installing positioner with cam in place, check the position of the spring (5) on diaphragm S/A (9) to ensure that it is centered on the diaphragm.*

# Cam Lobe Change

If it is necessary to change the cam lobe only (without changing actuator action or positioner action), then proceed as follows:

## CAUTION



*If cam is not at low signal line on lobe (low end of range), do not try to remove cam. The cam must be at low signal line. Select correct actuator and positioner action and proceed as follows.*

## NOTE



*Do not disturb cam holder (36) setting on rotary actuators : do not touch set screws (35).*

## Air to Open / Direct Acting Positioner

See Figure 18 on page 56 and Figure 19 on page 58.

1. Shut off supply pressure and signal to positioner. The valve is now closed and cam (26) is at low signal line on lobe.
2. With cam at low signal line, remove screw (28), lockwasher (51) and washer (27). Note the relative position of the cam lobe being changed and then remove the cam (26).
3. Select the desired cam lobe and replace cam (26) on cam shaft with low signal line of desired lobe against cam follower. Ensure the newly selected cam lobe is in the same relative position as the lobe noted in step 2.
4. Replace washer (27), lockwasher (51) and screw (28). Turn on supply pressure and signal to positioner. Check zero and span adjustment. Refer to “Zero Adjustment” and Span Adjustment on page 37.

## Air to Open / Reverse Acting Positioner

See Figure 18.

1. Shut off supply pressure and signal to positioner. The valve is now closed and cam (26) is at high signal line on lobe. Do not remove.
2. Run an independent regulated air line to the valve actuator in place of positioner output line. Slowly apply proper air pressure through the regulator to open the valve. Do not exceed designated supply pressure (handwheel may be used to open the valve in place of regulated air line). Align the travel indicator with the open end of travel scale. Do not over travel. Cam is now at low signal line on lobe.
3. With cam at low signal line, remove screw (28), lockwasher (51) and washer (27). Note the relative position of the cam lobe being changed and then remove the cam (26).

4. Select the desired cam lobe and replace cam (26) on cam shaft with low signal line of desired lobe against cam follower. Ensure that the newly selected cam lobe is in the same relative position as the lobe in step 3.
5. Replace washer (27), lockwasher (51) and screw (28). Reduce pressure applied in step 2 to zero (back off the handwheel if it was used). Disconnect the independent regulated air line to actuator and connect positioner output line. Connect supply pressure and signal to positioner. Check zero and span adjustment. Refer to “Span Adjustment” on page 37.

## **Air to Close / Direct Acting Positioner**

See Figure 18 on page 56 and Figure 19 on page 58.

1. Shut off supply pressure and signal to positioner. The valve is now open and cam (26) is at low signal line on lobe.
2. With cam at low signal line, remove screw (28), lockwasher (51) and washer (27). Note the relative position of the cam lobe being changed and then remove the cam (26).
3. Select the desired cam lobe and replace cam (26) on cam shaft with low signal line of desired lobe against cam follower. Ensure the newly selected cam lobe is in the same relative position as the lobe noted in step 2.
4. Replace washer (27), lockwasher (51) and screw (28). Check zero and span adjustment. Refer to “Zero Adjustment” and “Span Adjustment” on page 37.

## **Air to Close / Reverse Acting Positioner**

See Figure 18.

1. Shut off supply pressure and signal to positioner. The valve is now open and cam (26) is at high signal line on lobe. Do not remove.
2. Run an independent regulated air line to the valve actuator in place of positioner output line. Slowly apply proper air pressure through the regulator to shut the valve. Do not exceed designated supply pressure (handwheel may be used to close the valve in place of regulated air line). Align the travel indicator with the closed end of travel scale. Cam is now at low signal line on lobe.
3. With cam at low signal line, remove screw (28), lockwasher (51) and washer (27). Note the relative position of the cam lobe being changed and then remove the cam (26).
4. Select the desired cam lobe and replace cam (26) on cam shaft with low signal line of desired lobe against cam follower (4A). Ensure the newly selected cam lobe is in the same relative position as the lobe noted in step 3.
5. Replace washer (27), lockwasher (51) and screw (28). Reduce pressure applied in step 2 to zero (back off the handwheel if it was used). Disconnect the independent regulated air line to actuator and connect positioner output line. Connect supply pressure and signal to positioner. Check zero and span adjustment. Refer to “Zero Adjustment” and “Span Adjustment” on page 37.

# Field Mounting and Complete Calibration, Rotary Actuators

The following instructions should be followed for mounting and calibration of the 4700P/4700E and 4800P/4800E positioner. Define the proper valve action and positioner action. If the positioner is not on the valve, see Figure 19 on page 58 to mount positioner and cam coupling. Once the positioner body is assembled on the valve and the coupling is on the valve shaft, proceed to the proper section below.

## Air to Open / Direct Acting Positioner

See Figure 18 on page 56 and Figure 19 on page 58.

1. Do not connect air supply or signal to the positioner. The valve is closed.
2. Place lever S/A (3) to proper side (left or right) as designated by the appropriate cam selection table for the valve in question.
3. With the valve closed, place cam holder (36) with Truarc ring (37) into cam coupling (34).
4. Place the cam (26) onto the cam holder (36) so that the selected cam lobe is facing forward and will rest on the cam follower. (See appropriate table for cam selection.) Secure cam to cam holder with washer (27), lockwasher (51) and screw (28). Tighten the screw (28) while holding the cam (26).
5. With the valve closed, place the desired cam lobe's low signal line on the cam follower (4A). With the low signal line resting on the cam follower, sight across the face of the cam to the raised reference line on the positioner case and align (low signal line and reference line). Center cam between the two arms of the lever S/A (3), then tighten set screws (35) to 87 inch-lbs torque. See Figure 18 on page 56 for cam mounting.
6. Connect air supply and signal to positioner. Connect positioner output to valve actuator. Refer to connection diagram. Adjust signal to low end of signal (3 psig for a 3-15 psig range 4700P/4800P and 4 mA for 4-20 mA 4700E/4800E).
7. Adjust zero and span. Refer to "Zero Adjustment" and "Span Adjustment" on page 37.

## Air to Open / Reverse Acting Positioner

See Figure 18.

1. Do not connect air supply or signal to the positioner. The valve is closed.
2. Place lever S/A (3) to proper side (left or right), as designated by the appropriate cam selection table for the valve in question.
3. Run an independent regulated air line to the valve actuator in place of positioner output line. Slowly apply proper air pressure through the regulator to open the valve (handwheel may be used to open the valve in place of regulated air line). Align the travel indicator with the open end of travel scale. Do not over travel.
4. Place cam holder (36) with truarc ring (37) into cam coupling (34).

5. Place the cam (26) onto the cam holder (36) so that the selected cam lobe is facing forward and will rest on the cam follower. See appropriate table for cam selection. Secure cam (26) to cam holder (36) with washer (27), lockwasher (51) and screw (28). Tighten screw (28) while holding the cam (26).
6. With the valve open, place the desired cam lobe's low signal line on the cam follower (4A). With the low signal line resting on the cam follower, sight across the face of the cam to the raised reference line on the positioner case and align (low signal line and reference line). Center cam between the two arms of the lever S/A (3), then tighten set screws (35) to 87 inch-lbs torque. See Figure 18 on page 56 for cam mounting.
7. Slowly reduce pressure applied to actuator in step 3 to zero. If handwheel was used to place the valve in open position, back it off completely. Cam is at high signal line on lobe.
8. Disconnect the independent regulated air line to actuator and connect positioner output line. Connect supply pressure and signal to positioner.
9. Adjust signal to low end of signal (3 psig for a 3-15 psig range 4700P/4800P). Adjust zero and span. Refer to "Zero Adjustment" and "Span Adjustment" on page 37.

## Air to Close / Direct Acting Positioner

See Figure 18 on page 56 and Figure 19 on page 58.

1. Do not connect air supply or signal to the positioner, the valve is now open.
2. Note the valve position. The travel indicator should be approximately aligned with the open end of the travel scale. If not aligned, consult proper valve instruction for travel adjustment.
3. With the valve open, place lever S/A (3) to proper side (left or right) as designated by the appropriate cam selection table for the valve in question.
4. With the valve open, place cam holder (36) with truarc ring (37) into cam coupling (34).
5. Place the cam (26) onto the cam holder (36) so that the selected cam lobe is facing forward and will rest on the cam follower. Secure cam to cam holder with washer (27), lockwasher (51) and screw (28). Tighten screw (28) while holding the cam (26).
6. With the valve open, place the desired cam lobe's low signal line on the cam follower. With the low signal line resting on the cam follower sight across the face of the cam to the raised reference line on the positioner case and align (low signal line and reference line). Center cam between the two arms of the lever S/A (3), then tighten set screws (35) to 87 inch-lbs torque. See Figure 18 on page 56 for cam mounting.
7. Connect air supply and signal to positioner. Connect positioner output to the valve actuator. Refer to connection diagram for the valve in question. Adjust signal to low end of signal (3 psig for a 3-15 psig range 4700P/4800P and 4 mA for 4-20 mA 4700E/4800E). Adjust zero and span. Refer to "Zero Adjustment" and "Span Adjustment" on page 37.



# Air to Close / Reverse Acting Positioner

See Figure 18.

1. Do not connect air supply or signal to the positioner. The valve is now open.
2. Note the valve position. The travel indicator should be approximately aligned with the open end of the travel scale. If not aligned, consult proper valve instructions for travel adjustment.
3. Place lever S/A (3) to proper side (left or right) as designated by the appropriate cam selection table for the valve in question.
4. Run an independent regulated air line to the valve actuator in place of positioner output line. Slowly apply proper air pressure through the regulator to shut the valve. Do not exceed designated supply pressure. (Handwheel may be used to close the valve in place of regulated air line.)
5. With the valve closed, place cam holder (36) with truarc ring (37) into cam coupling (34).
6. Place the cam (26) into the cam holder (36) so that the selected cam lobe is facing forward and will rest on the cam follower. Secure cam to cam holder with washer (27), lockwasher (51) and screw (28). Tighten screw (28) while holding the cam (26).
7. With the valve closed, place the desired cam lobe's low signal line on the cam follower. With the low signal line resting on the cam follower sight across the face of the cam to the raised reference line on the positioner case and align (low signal line and reference line). Center cam between the two arms of the lever S/A (3), then tighten set screws (35) to 87 inch-lbs torque. See Figure 18 on page 56 for cam mounting.
8. Slowly reduce pressure applied to actuator in step 4 to zero. If handwheel was used to place the valve in closed position, back it off completely. The valve is now open. Cam is at high signal line on lobe.
9. Disconnect the independent regulated air line to actuator and connect positioner output line. Connect supply pressure and signal to positioner.
10. Adjust signal to low end of signal (3 psig for a 3-15 psig range 4700P/4800P). Adjust zero and span. Refer to "Zero Adjustment" and "Span Adjustment" on page 37.

# Field Mounting and Complete Calibration Reciprocating Valves using 87/88 Actuators

Define valve action and positioner action (4700E/4800E is direct action only). If lever S/A (3) is not on proper side (left or right) as determined from data from “Cam Lobe Selection and Lever Arm Orientation” on page 53, change to correct position. Refer to “Changing Lever S/A Orientation” on page 35. If positioner is not on the valve refer to Figure 5 on page 16 through Figure 9 on page 20 for mounting and linkage connection procedures. If positioner is reverse acting (4700P/4800P only), do not assemble cam to shaft at this time. Make pneumatic connections per Figure 10 on page 23 for action desired (4700P/4800P), or electrical and pneumatic connections for 4700E/4800E (direct action only). Proceed to proper section below.

## Air to Open / Direct Acting Positioner

See Figure 18 on page 56 and Figure 19 on page 58.

1. Apply lower value of instrument signal (3 psi for a 3-15 psi range 4700P/4800P and 4 mA for a 4700E/4800E).
2. Unlock zero locknut (4C) and turnbuckle locknut (107). Adjust zero by turning both the zero nut (4B) and turnbuckle (106) until the low signal line of the cam is aligned with the positioner case raised reference line and the travel indicator shows closed position. Retighten both locknuts.
3. Apply full scale value of instrument signal (15 psi or 20 mA) and note position of travel indicator. If travel is not correct, perform span adjustment. Refer to “Span Adjustment” on page 37.
4. Repeat zero and span adjustments per “Zero Adjustment” and “Span Adjustment” on page 37 until travel range is correct. After adjustments are satisfactory, re-tighten the spring locking screw (8), zero locknut (4C), and turnbuckle locknut (107).

## Air to Open / Reverse Acting Positioner (4700P/4800P only)

Figure 18.

1. Disconnect air line from positioner to actuator at actuator. Run an independent regulated air line to the actuator. Slowly apply proper air pressure through the regulator to open the valve (handwheel may be used to open the valve instead of regulated air line). Align the travel indicator with the open end of travel scale. Do not overtravel.
2. Place cam (26) on to cam shaft with selected cam lobe facing forward and low signal line approximately aligned with positioner case raised reference line. Secure cam to shaft using washer (27), lockwasher (51) and screw (28).
3. Slowly reduce pressure applied to actuator to zero. If handwheel was used, back it off completely. Cam will now be at high signal line.

4. Disconnect the independent regulated air line and connect the positioner output line to the actuator. Connect supply pressure and signal to the positioner.
5. Apply low value of instrument signal. (3 psi if 3-15 psi signal range) Unlock zero locknut (4C) and turnbuckle locknut (107). Adjust zero by turning both the zero nut (4B) and turnbuckle (106) until the low signal line of the cam is aligned with the positioner case raised reference line and the travel indicator shows opened position. Refer to Figure 5 on page 16 and Figure 18 on page 56. Re-tighten both locknuts.
6. Apply full scale value of instrument signal (15 psi) and note position of stroke scale indicator. If travel is not correct, perform span adjustment. Refer to "Span Adjustment" on page 37.
7. Repeat zero and span adjustments per "Zero Adjustment" and "Span Adjustment" on page 37 until travel range is correct. After adjustments are satisfactory, re-tighten the spring locking screw (8), zero locknut (4C), and turnbuckle locknut (107).

## **Air to Close / Direct Acting Positioner**

See Figure 18 on page 56 and Figure 19 on page 58.

1. Apply lower value of instrument signal (3 psi for a 3-15 psi range 4700P/4800P and 4 mA for a 4700E/4800E).
2. Unlock zero locknut (4C) and turnbuckle locknut (107). Adjust zero by turning both the zero nut (4B) and turnbuckle (106) until the low signal line of the cam is aligned with the positioner case raised reference line and the travel indicator shows opened position. Refer to Figure 5 on page 16 and Figure 18 on page 56. Re-tighten both locknuts.
3. Apply full scale value of instrument signal (15 psi or 20 mA.) and note position of travel indicator. If travel is not correct, perform span adjustment. Refer to "Span Adjustment" on page 37.
4. Repeat zero and span adjustments per "Zero Adjustment" and "Span Adjustment" on page 37 until travel range is correct. After adjustments are satisfactory, re-tighten the spring locking screw (8), zero locknut (4C), and turnbuckle locknut (107).

## **Air to Close/Reverse Acting Positioner (4700P/4800P only)**

See Figure 18.

1. Disconnect air line from positioner to actuator at actuator. Run an independent regulated air line to the actuator. Slowly apply proper air pressure through the regulator to close the valve (handwheel may be used to open the valve instead of regulated air line). Align the travel indicator with the closed end of travel scale. Do not overtravel.
2. Place cam (26) on to cam shaft with selected cam lobe facing forward and low signal line approximately aligned with positioner case raised reference line. Secure cam to shaft using washer (27), lockwasher (51) and screw (28).
3. Slowly reduce pressure applied to actuator to zero. If handwheel was used, back it off completely. Cam will now be at high signal line.

4. Disconnect the independent regulated air line and connect the positioner output line to the actuator. Connect supply pressure and signal to the positioner.
5. Apply low value of instrument signal. (3 psi if 3-15 psi signal range) Unlock zero locknut (4C) and turnbuckle locknut (107). Adjust zero by turning both the zero nut (4B) and turnbuckle (106) until the low signal line of the cam is aligned with the positioner case raised reference line and the travel indicator shows closed position. Refer to Figure 5 on page 16 and Figure 18 on page 56. Re-tighten both locknuts.
6. Apply full scale value of instrument signal (15 psi) and note position of stroke scale indicator. If travel is not correct, perform span adjustment. Refer to "Span Adjustment" on page 37.
7. Repeat zero and span adjustments per "Zero Adjustment" and "Span Adjustment" on page 37 until travel range is correct. After adjustments are satisfactory, re-tighten the spring locking screw (8), zero locknut (4C), and turnbuckle locknut (107).

#### NOTE



*Although this procedure is written for 87/88 actuators, it is, in general, applicable to calibration of any reciprocating actuator.*

## Damping Adjustment

The airflow to the actuator may be reduced by turning screw (20) clockwise. This adjustment may be required for smaller volume actuators if instability is observed. Turn clockwise until desired stability is obtained.

#### CAUTION



*Screw must never be backed out further than top flush with housing.*

# Positioner Action Change (4700P/4800P only)

Whenever it becomes necessary to change positioner action from direct to reverse or vice versa, it is important to be familiar with the following steps.

To remove or install the cam safely, the valve position must correspond to the low signal line on lobe.

The positioner supply line, the vent and the lever S/A must be reversed.

## From Air to Open / Direct to Air to Open/Reverse

1. Perform steps 1 and 2 from “Cam Lobe Change” on page 38 for Air to Open/Direct Acting Positioner. Cam is now removed.
2. Proceed to “Field Mounting and Calibration” section for Air to Open/Reverse Acting Positioner and proceed as stated.

## From Air to Open / Reverse to Air to Open/Direct

1. Perform steps 1, 2 and 3 from “Cam Lobe Change” on page 38 for Air to Open/Reverse Positioner. Cam is now removed.
2. Slowly reduce pressure applied to actuator to zero. If handwheel was used to place the valve in open position, back it off completely. The valve is now closed. Remove independent regulated air line from actuator.
3. Proceed to “Field Mounting and Calibration” section for Air to Open/Direct Acting Positioner and proceed as stated.

## From Air to Close / Direct to Air to Close/Reverse

1. Perform steps 1 and 2 from “Cam Lobe Change” on page 38 for Air to Close/Direct Acting Positioner. Cam is now removed.
2. Proceed to “Field Mounting and Calibration” section for Air to Close/Reverse Acting Positioner and proceed as stated.

## From Air to Close / Reverse to Air to Close/Direct

1. Perform steps 1, 2 and 3 from “Cam Lobe Change” on page 38 for Air to Close/Reverse Acting Positioner. Cam is now removed.
2. Slowly reduce pressure applied to actuator to zero. If handwheel was used to place the valve in closed position, back it off completely. The valve is now open. Remove independent regulated air line from actuator.
3. Proceed to “Field Mounting and Calibration” section for Air to Close/Direct Acting Positioner and proceed as stated.

# Maintenance

## WARNING



*Before starting any calibration or maintenance procedure on these positioners, ensure that the valves under control are isolated from the controlled process and that the area is verified as nonhazardous.*

## Pilot

See Figure 17.

To clean or replace deteriorated parts, the valve must be isolated from process. Shut off air supply. To minimize maintenance time, it is recommended that the entire pilot S/A (11) be replaced by a new S/A, so that the old unit can be worked on when time permits.

## Disassembly

1. Unscrew the pilot S/A (11) and disengage it from the body (1).  
**Note: Turn the pilot subassembly while removing it to prevent damage to the O-rings.**
2. Remove end plug and withdraw the spring, plug and extension pin. If necessary, use a penetrating oil to free parts.

## CAUTION



*Do not disassemble or adjust extension pin.*

3. Wipe the parts with a clean soft lint free cloth and blow compressed air through the orifices. Use isopropyl alcohol to clean. Do not use chloride based solvents.

## Reassembly

1. Install three new O-rings on the pilot spool. Put a light coating of silicone grease on each O-ring.
2. Replace the extension pin and the plug, countersunk end first into the pilot spool. The plug should slide into the pilot spool by its own weight.
3. Install the spring in the pilot spool. The end having the smallest diameter must be in contact with the plug. Screw the pilot end plug into the pilot spool.
4. Install the pilot S/A (11) into the body (1).

# Body

Shut off the air supply. Disconnect air lines, linkage if reciprocating, and electrical connections if 4700E/4800E. If positioner is reverse acting, refer to applicable section under “Cam Lobe Change” on page 38 to safely remove cam. Remove screw (28), washer (27), cam (26). Separate positioner from actuator by removing screws (29) and washers (30).

## Disassembly

See Figure 18 on page 56 and Figure 19 on page 58.

1. Remove pressure gauges (12) (13), and on 4700P/4800P only (14).
2. Remove the pilot S/A (11).
3. Remove retaining ring (17), washer (16), lever S/A (3), and spring (5).
4. On 4700E/4800E only, remove 4 screws (21) to separate I/P module from body.

### CAUTION



*Do not damage or lose the three O-rings on bottom of module.*

5. Remove cap screws (10) and separate body S/A from the case S/A.
6. Remove the diaphragm assembly (9), and reducer plate if 6-30 psi range 4700P/4800P.
7. Clean the body (1). Avoid the use of detergents that might deteriorate the diaphragm S/A. Use isopropyl alcohol. Do not use chloride-based solvents.
8. On 4700E/4800E, carefully remove the three O-rings from the bottom of the module. Inspect for any nicks or deterioration. Replace if necessary. Clean bottom of module using isopropyl alcohol. Carefully reassemble O-rings into grooves. Make sure they are seated in bottom of groove.

### CAUTION



*Do not use any lubrication on O-rings or base.*

# Reassembly

See Figure 18 on page 56 and Figure 19 on page 58.

1. Position the diaphragm assembly (9) on the case S/A. If positioner is 6-30 psi range, install reducer plate per Figure 19. Secure the body S/A to the case S/A with cap screws (10). Tighten evenly to 60 inch-lbs of torque.
2. Replace spring (5), lever S/A (3), washer (16), and retaining ring (17).
3. On 4700E/4800E, carefully place module in position against body making sure that O-rings do not come out of grooves. Secure to body using screws (21).
4. Install the pilot assembly (11) and pressure gauges.
5. Install the positioner on the actuator. Reconnect air lines, electrical leads if 4700E/4800E, and coupling linkage if mounted on reciprocating valve.
6. Assemble cam to shaft per procedure under “Cam Lobe Change” on page 38. Recalibrate per appropriate Valve Action/Positioner Action calibration section.

# Diaphragm

If the diaphragm is deteriorated, replace the diaphragm assembly. This requires separation of the body and case subassemblies as outlined under “Disassembly” on page 48.

# I/P Module

Replacement of the I/P module requires removal of electrical connections, including conduit if used. Remove positioner from the valve if module mounting screws are not accessible. Remove and replace module as outlined under “Disassembly” on page 48.

## NOTE



*There are no adjustments in the I/P module.*



# Bypass Valve Option (4700P only)

See Figure 20 on page 60.

## Assembly to Positioner

Figure 20 on page 60.

It may be necessary to remove positioner from the valve to assemble bypass.

1. Remove air connections, vent plug, and instrument gauge.
2. Clean surface of body and remove any thread sealant left in threaded ports.
3. Install O-rings (50) in each of the four recesses on the rear surface of the module (45), making sure they are seated in the bottom of the recess.
4. Assemble to positioner using four 8-32 x 1.25" long screws (21).
5. Reinstall vent plug, instrument gauge, and air connections.

## Disassembly

1. To remove from positioner, reverse assembly steps 5 and 4.

### NOTE



*Do not use silicone grease on silicone O-rings.*

2. To replace the valve (48) O-ring seals, remove retaining ring (49) and slide the valve out of block. Remove O-rings (46) and (47), replace with new rings which have a thin coat of Krytox™ or other silicone-compatible lubricant. Replace the valve in block and secure with retaining ring (49).
3. Reassemble bypass module to positioner.

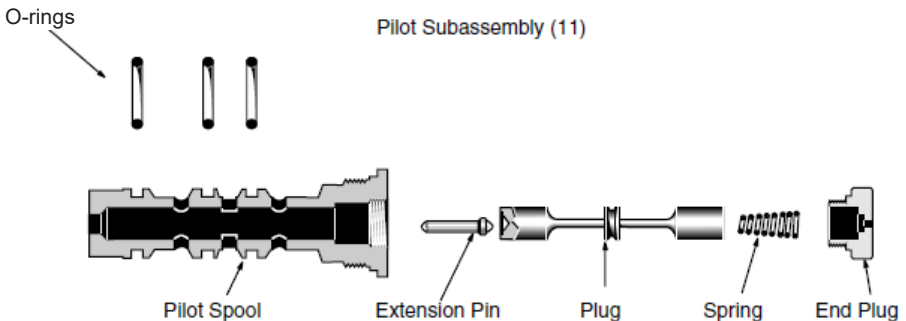


Figure 17 - Pilot Assembly

# Troubleshooting

The following conditions must exist to ensure satisfactory operation of the positioner:

- The valve must be properly mounted in the line so that the actuator counters the dynamic torque and the valve operates as desired on air failure.
- Supply pressure is adequate for the valve operation. See pressure drop tables in the valve catalog.
- Correct positioner installation.
- Correct positioning of the feedback (cam, bearing lever, etc.).
- Proper cam selection.
- Supply, instrument signal and output connections must be correct for the positioner action (direct or reverse).
- Air tight connections.
- Correct position of the bypass.

In case of malfunction, check following in order given:

1. Check zero adjustment and adjust the zero nut (4B) if necessary. Lock with locknut (4C).
2. Check span adjustment and adjust if necessary.
3. Adjust instrument signal pressure from minimum to maximum and observe the corresponding gauge. If Instrument gauge reading does not respond to the signal, the diaphragm S/A may be broken. Replace the defective part.
4. Positioner insensitivity may be the result of a sticking pilot spool whose movement may be impeded by:
  - a. Foreign matter such as dirt, metal particles, etc.
  - b. Partial blockage of air passages caused by too much oil in the air lines.
  - c. Blocking of vent holes.

# Split Range Operation - 4700P/4800P

Split ranging permits the operation of two valves in sequence from one control instrument signal. The total stroking of each valve occurs with one half the signal (3-9 psig or 9-15 psig). The following table shows, for example, the plug positions of two valves (both air to close action, open on air failure operating in split range) with a 3-15 psig instrument signal.

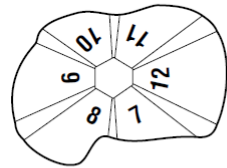
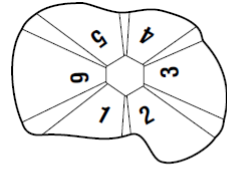
**Table 3 - Split Range Operation**

Instrument Signal		Air Signal to Close No. 1 Valve Plug Position (3-9 psig)	Air Signal to Close No. 2 Valve Plug Position (9-15 psig)
psig	mbar		
3	207	Full Open	Full Open
6	414	Half Open	Full Open
9	620	Closed	Full Open
12	827	Closed	Half Open
15	1034	Closed	Closed

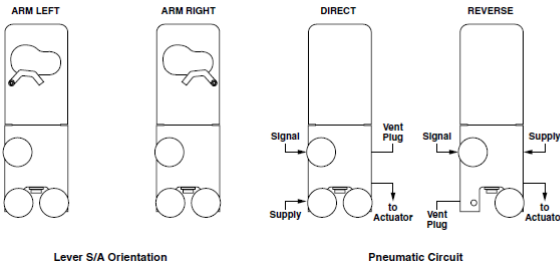
# Cam Lobe Selection and Lever Arm Orientation

## Camflex II

Valve Action	Positioner Action	Range and Characteristic	Cam Lobe
Air to Open	Direct Arm Right	0-100 % Lin	5
		0-100 % Perc	2
		0-50 % Lin	10
		50-100 % Lin	9
Air to Close	Reverse Arm Left	0-100 % Lin	11
		0-100 % Perc	1
		0-50 % Lin	4
		50-100 % Lin	3
Air to Open	Direct Arm Left	0-100 % Lin	11
		0-100 % Perc	1
		0-50 % Lin	4
		50-100 % Lin	3
Air to Close	Reverse Arm Right	0-100 % Lin	5
		0-100 % Perc	2
		0-50 % Lin	10
		50-100 % Lin	9

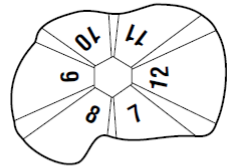
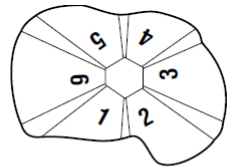


Camflex II Cam  
Part No. 041126-181

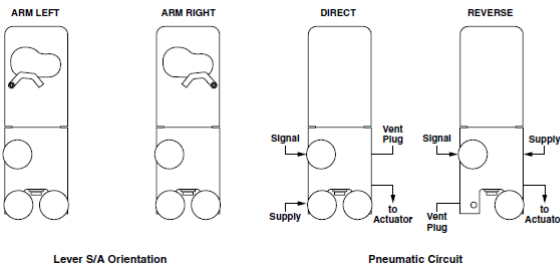


## 87/88 Actuator

Valve Action	Positioner Action	Range and Characteristic	Cam Lobe
Air to Open	Direct Arm Right	0-100 % Lin	5
		0-100 % Perc	2*
		0-50 % Lin	10
		50-100 % Lin	9
Air to Close	Reverse Arm Left	0-100 % Lin	11
		0-100 % Perc	1*
		0-50 % Lin	4
		50-100 % Lin	3
Air to Open	Direct Arm Left	0-100 % Lin	11
		0-100 % Perc	1*
		0-50 % Lin	4
		50-100 % Lin	3
Air to Close	Reverse Arm Right	0-100 % Lin	5
		0-100 % Perc	2*
		0-50 % Lin	10
		50-100 % Lin	9



87/88 Cam  
Part No. 041126-183

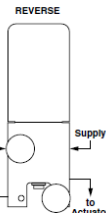
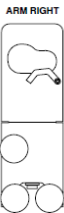
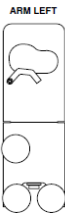
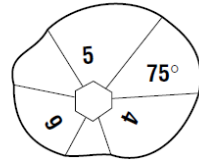
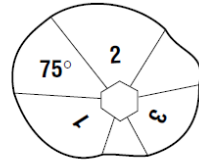


\*Do not use with % valve trim.

# Cam Lobe Selection and Lever Arm Orientation (Cont.)

## MiniTork II (counter clockwise motion)

Valve Action	Positioner Action	Range and Characteristic	Cam Lobe
Air to Open	Direct Arm Right	0-100 % Perc 0-50 % Perc 50-100 % Perc	4 3 2
	Reverse Arm Left	0-100 % Perc 0-50 % Perc 50-100 % Perc	1 6 5
Air to Close	Direct Arm Left	0-100 % Perc 0-50 % Perc 50-100 % Perc	1 6 5
	Reverse Arm Right	0-100 % Perc 0-50 % Perc 50-100 % Perc	4 3 2



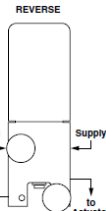
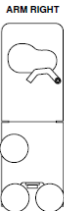
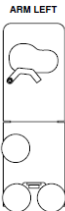
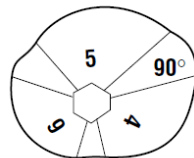
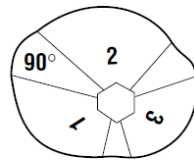
Lever S/A Orientation

Pneumatic Circuit

MiniTork II Cam  
Part No. 021128-006

## V-Max (clockwise motion)

Valve Action	Positioner Action	Range and Characteristic	Cam Lobe
Air to Open	Direct Arm Right	0-100 % Perc 0-50 % Perc 50-100 % Perc	4 3 2
	Reverse Arm Left	0-100 % Perc 0-50 % Perc 50-100 % Perc	1 6 5
Air to Close	Direct Arm Left	0-100 % Perc 0-50 % Perc 50-100 % Perc	1 6 5
	Reverse Arm Right	0-100 % Perc 0-50 % Perc 50-100 % Perc	4 3 2



Lever S/A Orientation

Pneumatic Circuit

36005 V-Max

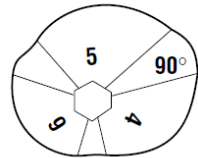
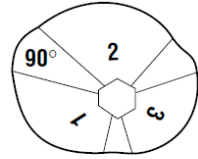
Cam  
Part No. 021128-007

# Cam Lobe Selection and Lever Arm Orientation

## (Cont.)

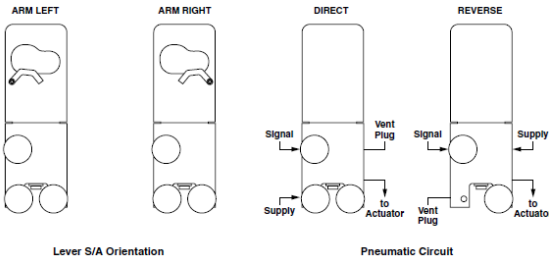
### Butterfly Valves (clockwise motion)

Valve Action	Positioner Action	Range and Characteristic	Cam Lobe
Air to Open	Direct Arm Right	0-100 % Perc 0-50 % Perc 50-100 % Perc	1 6 5
	Reverse Arm Left	0-100 % Perc 0-50 % Perc 50-100 % Perc	4 3 2
Air to Close	Direct Arm Left	0-100 % Perc 0-50 % Perc 50-100 % Perc	4 3 2
	Reverse Arm Right	0-100 % Perc 0-50 % Perc 50-100 % Perc	1 6 5



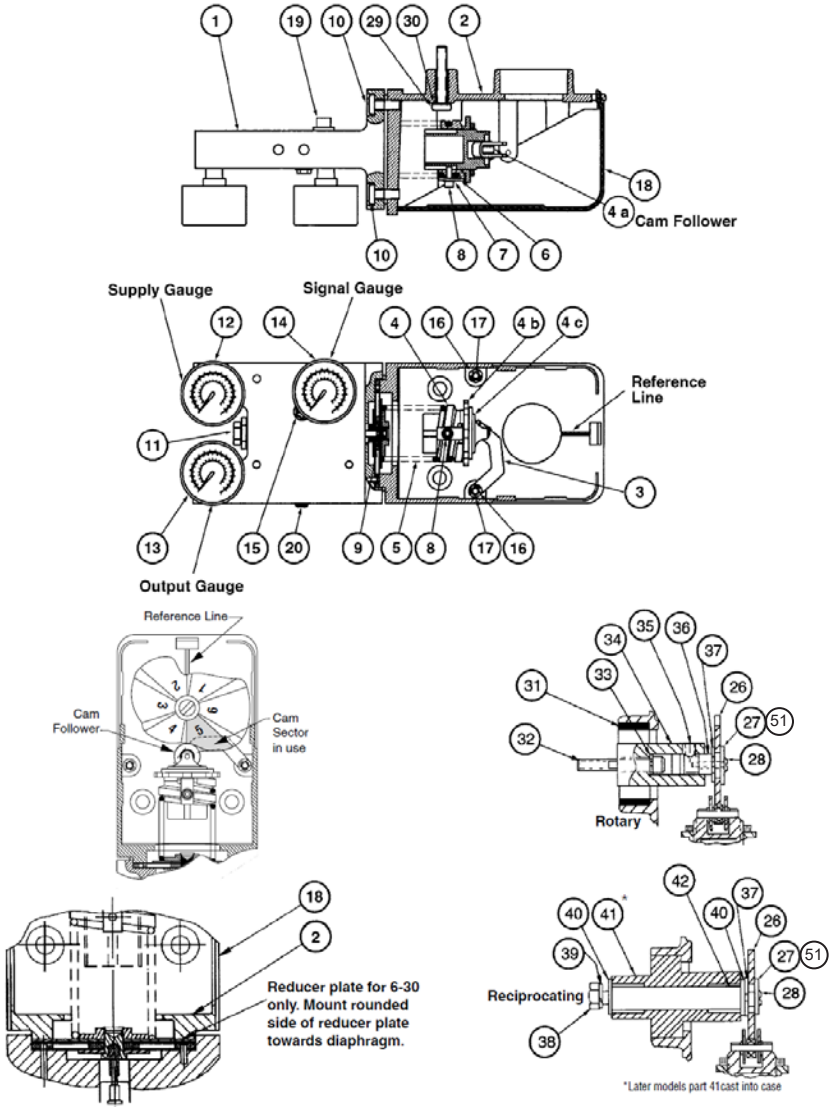
33000  
39003  
39000

Cam  
Part No. 021128-007



# Parts Reference 4700P/4800P

## 3-15 and 6-30 Range



**Figure 18 - 4700P/4800P 3-15 and 6-30 Ranges**

**Table 4 - Parts Reference 4700P/4800P 3-15 and 6-30 Range**

Ref. No.	Description	Ref. No.	Description
1	Body S/A	26	Cam
2	Case S/A	27	Washer
3	Lever S/A	28	Pan Head Screw
4	Spring End	29	Socket Head Screw
4A	Cam Follower	30	Lockwasher
4B	Zero Nut	31	Gasket
4C	Zero Lock Nut	32	Socket Head Screw
5	Spring, Feedback	33	Lockwasher
6	Clamp	34	Coupling
7	Lockwasher	35	Socket Head Set Screw
8	Socket Head Screw	36	Cam Holder
9	Diaphragm S/A	37	Truarc Ring
10	Screw	38	Cap Screw
11	Pilot S/A	39	Lockwasher
12	Supply Gauge	40	Washer
13	Output Gauge	41	Post Hub
14	Instrument Gauge	42	Input Shaft
15	Screw, Washer Head	51	Lockwasher
16	Washer		
17	Retaining Clip		
18	Cover, Case		
19	Vent Plug		
20	Screw, Sealing, Set 5/16-24 x .5		
21	—		
22	—		
23	—		
24	—		
25	—		



# Parts Reference 4700E/4800E

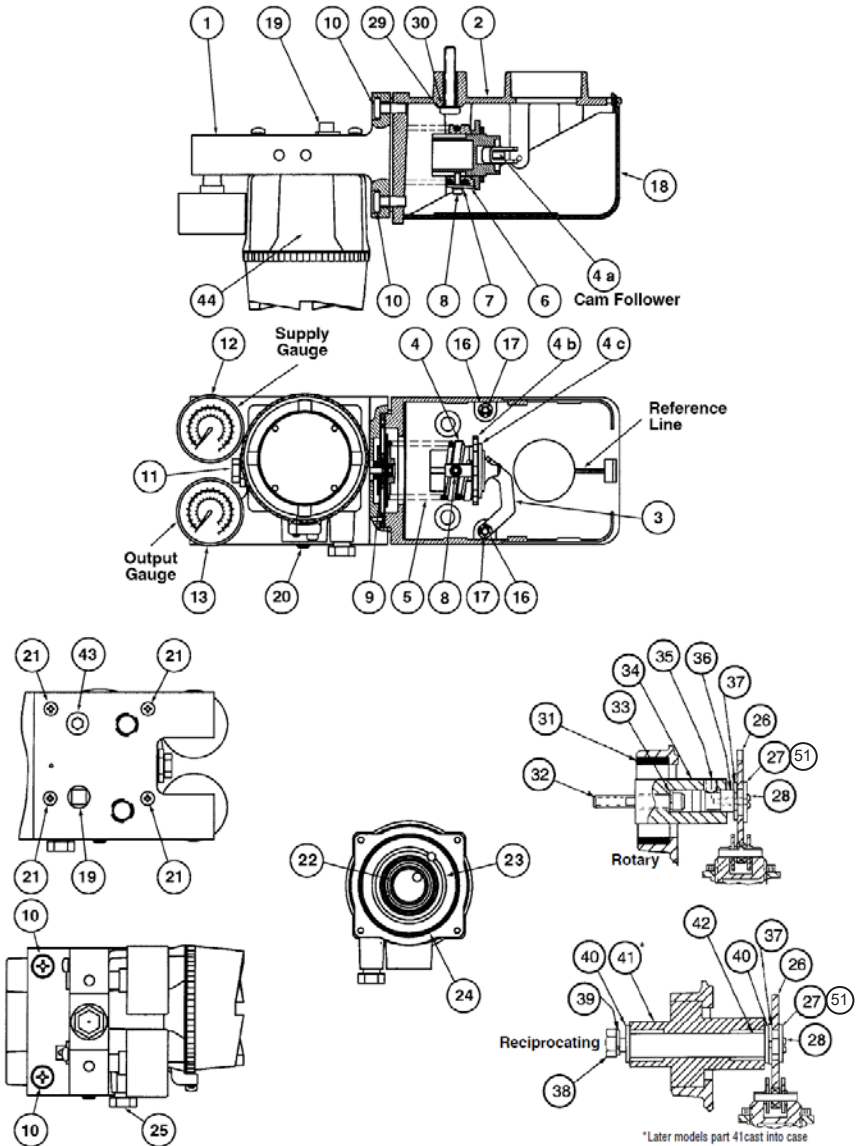


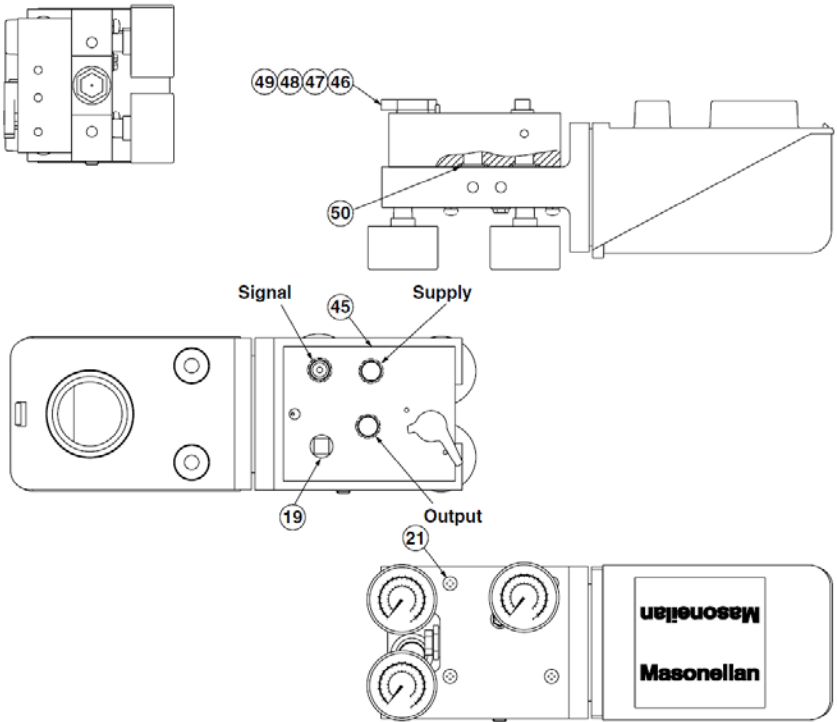
Figure 19 - 4700E/4800E

**Table 5 - Parts Reference 4700E/4800E**

Ref. No.	Description	Ref. No.	Description
1	Body S/A	26	Cam
2	Case S/A	27	Washer
3	Lever S/A	28	Pan Head Screw
4	Spring End	29	Socket Head Screw
4A	Cam Follower	30	Lockwasher
4B	Zero Nut	31	Gasket
4C	Zero Lock Nut	32	Socket Head Screw
5	Spring, Feedback	33	Lockwasher
6	Clamp	34	Coupling
7	Lockwasher	35	Socket Head Set Screw
8	Socket Head Screw	36	Cam Holder
9	3-15 Diaphragm S/A	37	Truarc Ring
10	Screw	38	Cap Screw
11	Pilot S/A	39	Lockwasher
12	Supply Gauge	40	Washer
13	Output Gauge	41	Post Hub
14	—	42	Input Shaft
15	—	43	Plug, Pipe 1/4" NPT
16	Washer	44	I/P Module Assembly
17	Retaining Clip	51	Lockwasher
18	Cover, Case		
19	Vent Plug		
20	Screw, Sealing, Set 5/16-24 x .5		
21	Screw 8-32 x 1.25		
22	O-ring .81" ID		
23	O-ring 1.31" ID		
24	O-ring 2.38" ID		
25	Breather		

# Parts Reference

Ref.No.	Description
19	Vent Plug
21	Screw 8-32 x 1.25 SEMS
45	Bypass S/A
46	O-ring
47	O-ring
48	Valve, Bypass
49	Ring, Retaining
50	O-ring



**Figure 20 - Bypass Option (4700P only)**

# Specifications

**Table 6 - Specification Data**

Item	Description	
Type	Cam feedback, pneumatic, force balanced by electropneumatic positioner uses current to pneumatic converter to generate pneumatic operating signal	
Action	Direct: increasing signal increases output reverse: increasing signal decreases output Note: Reverse action is available only on the 4700P/4800P Pneumatic Positioner	
Characteristics	Linear Equal Percentage Custom	
Maximum Air Consumption	0.3 scf/min - 25 psig supply (4700) 0.5 scf/min - 25 psig supply (4800)	
Temperature Effects Span Error (Typical)	Temp Range (°C) -40 to -20 -20 to +60 +60 to +85	Error .31% per °C .06% per °C .11% per °C
Supply Pressure Influence	Less than 0.25% stroke change per psi supply change	
Maximum Air Supply Rating	Dictated by actuator, but never greater than 100 psig	
Connections	Pneumatic: 1/4" NPT (4700) or 3/8" (4800) Electrical: 1/2" NPT or M20	
Weight	4700P: 3.5 lbs (1.6 kg) - 4800P: 4.2 lbs (1.9 kg) 4700E: 4.7 lbs (2.1 kg) - 4800E: 5.3 lbs (2.4 kg)	
	4700P	4700E
Deadband	<0.2% of span	<0.5% of span
Hysteresis	<0.2% of span	<0.5% of span
Repeatability	Within 0.2% of span	Within 0.5% of span
Sensitivity	Better than 0.2% of span	Better than 0.3% of span
Conformity	+1% of span	+1% of span
Input Resistance 4-20 mA signal		170 Ohms nominal

# Drawings

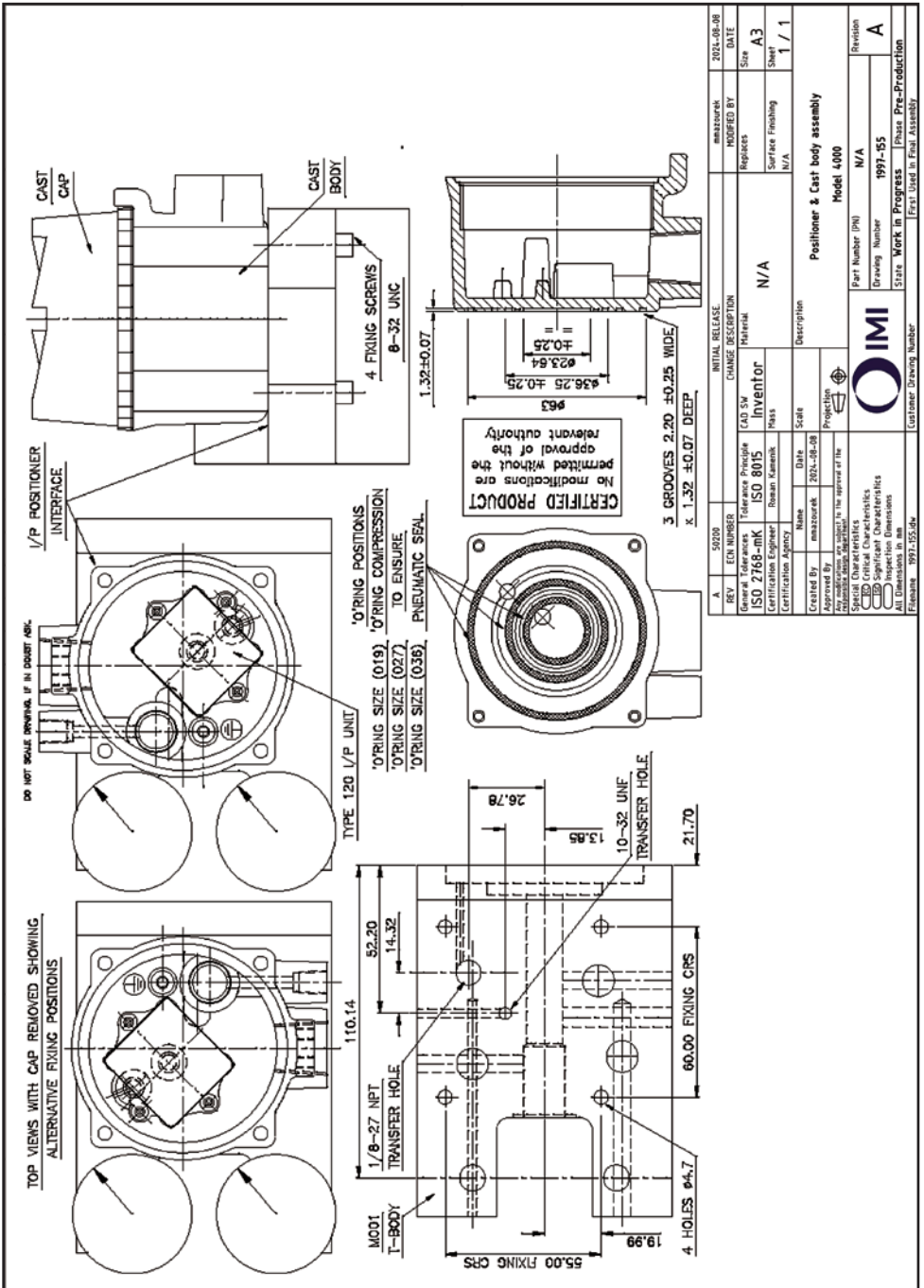


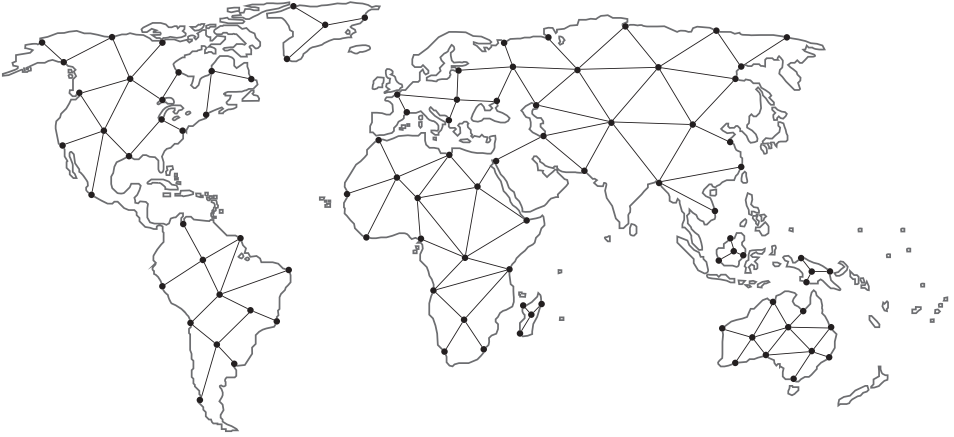
Figure 21 - Positioner and Cast Body Assembly





# Find the nearest local Channel Partner in your area:

[valves.bakerhughes.com/contact-us](https://valves.bakerhughes.com/contact-us)



## Tech Field Support and Warranty:

Phone: +1-866-827-5378

[valvesupport@bakerhughes.com](mailto:valvesupport@bakerhughes.com)

[valves.bakerhughes.com](https://valves.bakerhughes.com)

Copyright 2024 Baker Hughes Company. All rights reserved. Baker Hughes provides this information on an "as is" basis for general information purposes. Baker Hughes does not make any representation as to the accuracy or completeness of the information and makes no warranties of any kind, specific, implied or oral, to the fullest extent permissible by law, including those of merchantability and fitness for a particular purpose or use. Baker Hughes hereby disclaims any and all liability for any direct, indirect, consequential or special damages, claims for lost profits, or third party claims arising from the use of the information, whether a claim is asserted in contract, tort, or otherwise. Baker Hughes reserves the right to make changes in specifications and features shown herein, or discontinue the product described at any time without notice or obligation. Contact your Baker Hughes representative for the most current information. The Baker Hughes logo, Masoneilan, Camflex, V-Max and MiniTork are trademarks of Baker Hughes Company. Other company names and product names used in this document are the registered trademarks or trademarks of their respective owners.