

21022 and 164935 Dual Axial Probe Housing Assembly

Datasheet

Bently Nevada Machinery Condition Monitoring

141601 Rev. G

Description

The 21022 Dual Axial Probe Housing Assembly consists of two proximity probes installed in an externally mounted protective enclosure. It is intended for mounting on the end of a machine nearest the thrust bearing to allow both probes to observe the end of the shaft for axial thrust position movement. The enclosure mounts on the machine case using four standard machine screws. The probes are mounted in sleeve/adaptor assemblies, which are installed directly onto the machine case through two 3/4-in NPT threaded holes.

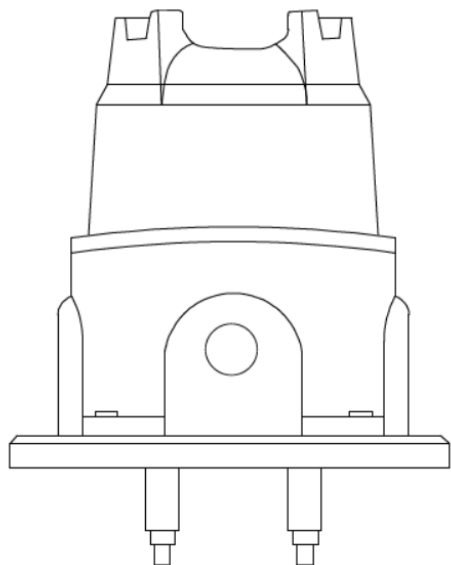

The dual axial position housing meets the American Petroleum Institute's (API) 670 Standard for axial thrust position transducer housings. The external mounting allows probe adjustments from outside the machine, while protecting the proximity probes, probe leads, and extension cables from dust, splashing liquid, or other environmental factors. A removable cover on the enclosure provides access for setting the probe gaps.

Specifications

Mechanical

Housing Material	
21022	Aluminum alloy housing (sand cast, 0.3% copper free) with sleeves fabricated from 304 stainless steel
164935	Stainless steel 316L housing with sleeves fabricated from 304 stainless steel
Total Housing Weight (typical)	3.6 kg (8 lb)
Temperature Range	
	-51°C to +177°C (-60°F to +351°F).
3300 XL 8 mm or 3300 XL 11 mm probe	 Exposing the 3300 XL 8 mm or 11 mm probe to temperatures below -34°C (-30°F) may cause premature failure of the probe pressure seal.

Ordering Information



For the detailed listing of country and product specific approvals, refer to the *Approvals Quick Reference Guide* (108M1756) available from Bently.com.

Standard version

21022 - AA-BB-CCC-DD

A: Probe Option, with Connector

00	Probe not required
12	3300 XL 8 mm probe
18	3300 XL 8 mm, BASEEFA
23	3300 XL 8 mm, CSA
26	3300 XL NSv probe
27	3300 XL NSv Probe, Multiple approvals
28	3300 XL 8 mm probe, Multiple approvals
29	3300 XL 11 mm probe
30	3300 XL 11 mm probe, Multiple approvals



If option 00 (probe not required) is selected for Option A, then Option B (Probe Cable Length Option) must also be 00.

B: Probe Cable Length Option

00	Probe cable not required
05	0.5 metre (20 in)
10	1.0 metre (39 in)
12	12.0 inches
18	18.0 inches
24	24.0 inches
30	30.0 inches
36	36.0 inches



3300 XL 11 mm Probe not available with 0.5 meter Probe Cable Length.

C: Probe Penetration Option

Probe penetration dimensions greater than 305 mm (12 in) require additional sleeve support near the probe to prevent a resonance from occurring. Sleeve adjustment range is ± 13 mm (± 0.5 in).

Order in increments of 0.1 in (2.54 mm) for 21022; for UK0104, order in increments of 0.5 in (13 mm).

Minimum Length

010	1.0 in (25 mm) For all probes except 3300 XL 11mm
012	1.2 in (30.5 mm) For 3300 XL 11mm Probes

Maximum Length

120	12.0 in (305 mm)
------------	------------------



For penetration lengths between 1.0 and 2.0 inches, counter-bore may be required in machine case to reduce probe side view and/or rearview effects.

D: Fittings Option

00	Without fittings
01	One 3/4-14 NPT fitting; three 3/4-14 NPT plugs
02	Two 3/4-14 NPT fittings; two 3/4-14 NPT plugs
03	Two cable seal grips with grommets for cable sizes 1/8-in to 3/16-in, 1/4-in to 5/16-in, 5/16-in to 3/8-in; two 3/4-14 to 1/2-14 NPT reducers
04	Three 3/4-14 NPT plugs



Fittings option -01 thru -04 are supplied as a kit and are not installed when the housing is shipped.

Stainless Steel

164935 - AA-BB-CCC-DD

A: Probe Option, with Connector

00	Probe not required
12	3300 XL 8 mm probe
26	3300 XL NSv probe
27	3300 XL NSv Probe, Multiple approvals
28	3300 XL 8 mm probe, Multiple approvals
29	3300 XL 11 mm probe
30	3300 XL 11 mm probe, Multiple approvals

 If option 00 (probe not required) is selected for Option A, then Option B (Probe Cable Length Option) must also be 00.

B: Probe Cable Length Option

00	Probe cable not required
05	0.5 metre (20 in)
10	1.0 metre (39 in)

 3300 XL 11 mm Probe not available with 0.5 meter Probe Cable Length.

C: Probe Penetration Option

Probe penetration dimensions greater than 305 mm (12 in) require additional sleeve support near the probe to prevent a resonance from occurring. Sleeve adjustment range is ±13 mm (±0.5 in).

Order in increments of 0.1 in (2.54 mm) for 21022; for UK0104, order in increments of 0.5 in (13 mm).

Minimum Length

010	1.0 in (25 mm) For all probes except 3300 XL 11mm
012	1.2 in (30.5 mm) For 3300 XL 11mm Probes

Maximum Length

120	12.0 in (305 mm)
------------	------------------

 For penetration lengths between 1.0 and 2.0 inches, counter-bore may be required in machine case to reduce probe side view and/or rearview effects.

D: Fittings Option

00	Without fittings
01	One 3/4-14 NPT fitting; three 3/4-14 NPT

	plugs
02	Two 3/4-14 NPT fittings; two 3/4-14 NPT plugs
03	Two 3/4-14 NPT fittings; Two cable seal grips with grommets for cable sizes 1/8-in to 3/16-in, 1/4-in to 5/16-in, 5/16-in to 3/8-in; Two 3/4-14 to 1/2-14 NPT reducers
04	Three 3/4-14 NPT plugs

 Fittings option -01 thru -04 are supplied as a kit and are not installed when the housing is shipped.

Accessories

Individual Sleeve

40467-0000-BBBB

B: Probe Penetration Length	
A option from 21022 or UK0104 Dual Axial Housing part number	This option is the probe sleeve length in 0.01 in. Only order this option in increments of 0.1 in (the last digit of this option is always 0).
All options	
To determine the probe penetration length -	<p>When the original housing part number is known:</p> <p>B = Probe penetration option from original housing (21022 option C) + 0160.</p> <p>Example: original part number is 21022-12-10-040-00. B option for replacement sleeve is (0400 + 0160) = 0560</p>
	<p>When the original housing part number is unknown:</p> <p>Measure the total probe sleeve length (do not include the probe tip length). For option B, use the following formula:</p> $B = (\text{total probe sleeve length}) - (2.4)$ <p>Example: Probe sleeve measures 6 inches long. B option for the individual sleeve is (0600-0240) = 0360.</p>
Minimum Probe Sleeve Penetration Length	
Option B	<p>All probes except NSv and 11mm: 2.6 in (66 mm) = 0260</p> <p>3300 XL NSv: 2.7 in (69 mm) = 0270</p> <p>3300 XL 11mm: 2.0 in (51mm) = 0200</p>
Maximum Probe Penetration Length	
	All probes: 13.6 in (345 mm) = 1360

Spare 3300 XL 8mm Reverse Mount Probe, 3/8-24 UNF threads

330105-02-12-CC-DD-EE

C: Total Length Option	
05	0.5 metre (1.6 feet)
10	1.0 metre (3.3 feet)
15	1.5 metre (4.9 feet)
20	2.0 metres (6.6 feet)
50	5.0 metres (16.4 feet)
90	9.0 metres (29.5 feet)
D: Connector Option	
00	Connector not installed
02	Miniature ClickLoc coaxial connector
E: Agency Approval Option	
00	Not Required
05	Multiple Approvals

Spare 3300 XL NSv Reverse Mount Probe, 3/8-24 UNF threads

330906-02-12-CC-DD-EE

C: Total Length Option	
05	0.5 metre (1.6 feet)
10	1.0 metre (3.3 feet)
50	5.0 metres (16.4 feet)
70	7.0 metres (22.9 feet)
D: Connector Option	
00	Connector not installed
02	Miniature ClickLoc coaxial connector
E: Agency Approval Option	
00	Not Required
05	Multiple Approvals

Spare 3300 XL Imm Reverse Mount Probe, 3/8-24 UNF threads

330705-02-18-CC-DD-EE

C: Total Length Option

10	1.0 metre (3.3 feet)
50	5.0 metres (16.4 feet)
90	9.0 metres (29.5 feet)

D: Connector Option

00	Connector not installed
02	Miniature ClickLoc coaxial connector

E: Agency Approval Option

00	Not Required
05	Multiple Approvals

Graphs and Figures

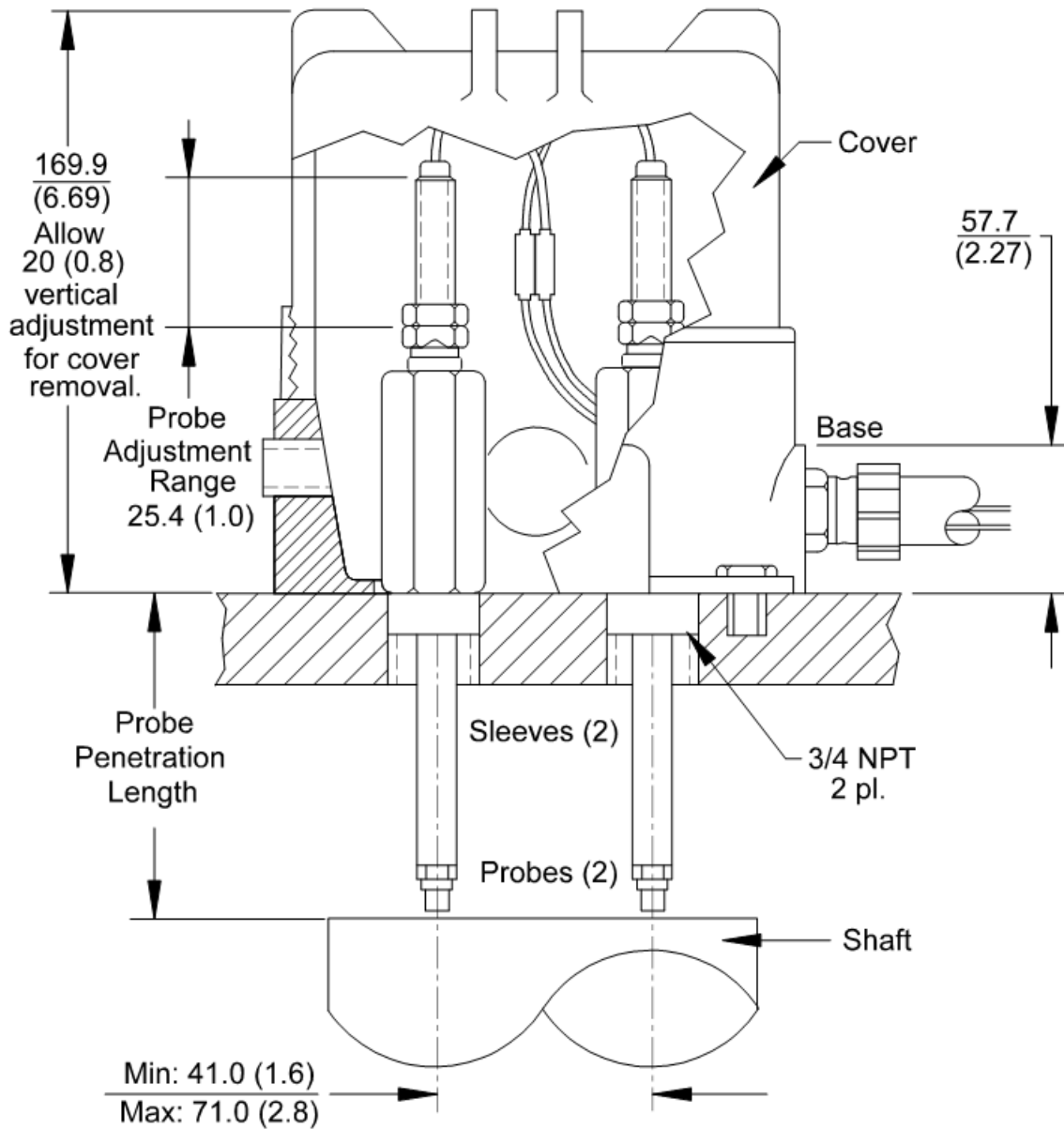

Figure 1: 21022 Dual Axial Probe Housing Assembly Dimensions, Side View

Dimensions are in millimeters (inches).

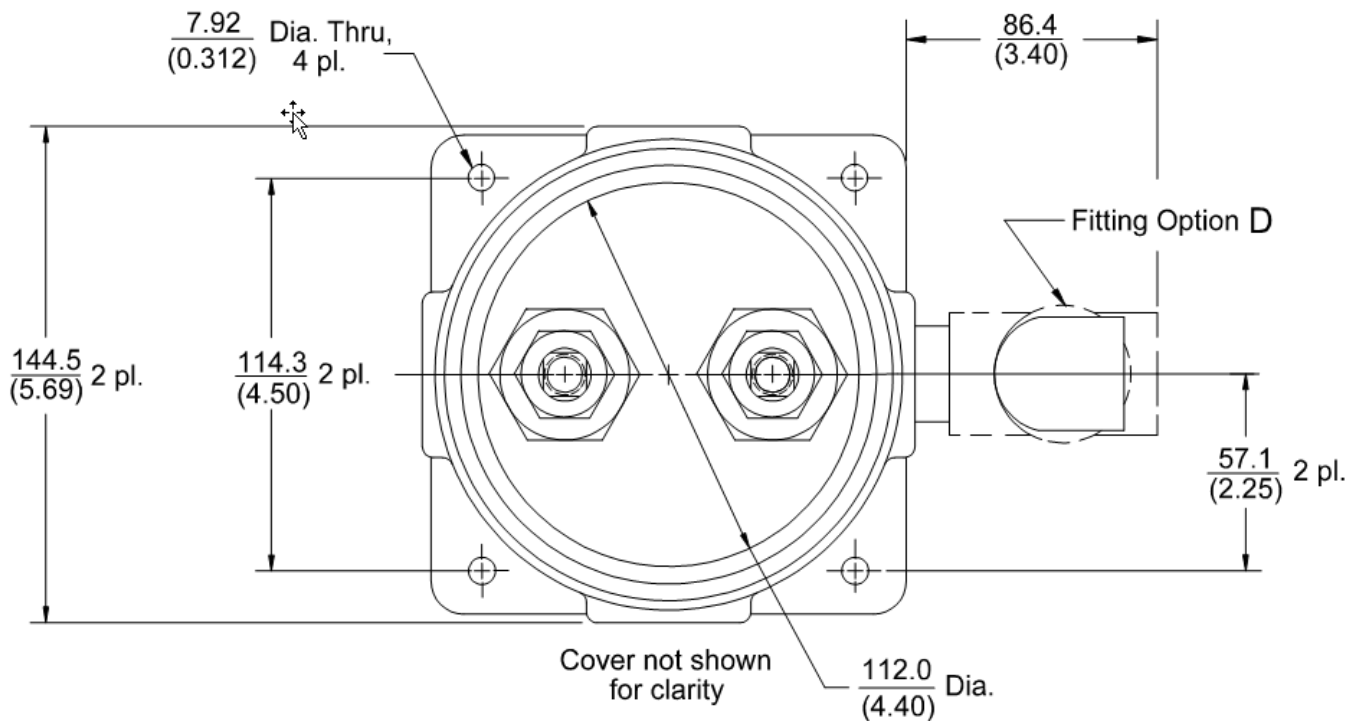

Figure 2: 21022 Dual Axial Probe Housing Assembly Dimensions, Top View

Dimensions are in millimeters (inches).

Copyright 2020 Baker Hughes Company. All rights reserved.



Bently Nevada, Orbit Logo and Proximitor are registered trademarks of Bently Nevada, a Baker Hughes Business, in the United States and other countries. The Baker Hughes logo is a trademark of Baker Hughes Company. All other product and company names are trademarks of their respective holders. Use of the trademarks does not imply any affiliation with or endorsement by the respective holders.

Baker Hughes provides this information on an "as is" basis for general information purposes. Baker Hughes does not make any representation as to the accuracy or completeness of the information and makes no warranties of any kind, specific, implied or oral, to the fullest extent permissible by law, including those of merchantability and fitness for a particular purpose or use. Baker Hughes hereby disclaims any and all liability for any direct, indirect, consequential or special damages, claims for lost profits, or third party claims arising from the use of the information, whether a claim is asserted in contract, tort, or otherwise. Baker Hughes reserves the right to make changes in specifications and features shown herein, or discontinue the product described at any time without notice or obligation. Contact your Baker Hughes representative for the most current information.

The information contained in this document is the property of Baker Hughes and its affiliates; and is subject to change without prior notice. It is being supplied as a service to our customers and may not be altered or its content repackaged without the express written consent of Baker Hughes. This product or associated products may be covered by one or more patents. See [Bentley.com/legal](https://www.bentley.com/legal).

1631 Bently Parkway South, Minden, Nevada USA 89423
Phone: 1.775.782.3611 or 1.800.227.5514 (US only)
[Bentley.com](https://www.bentley.com)